

**INDIAN  
PHARMACOPOEIA  
2007**

**Volume 1**

**THE INDIAN PHARMACOPOEIA COMMISSION  
GHAZIABAD**

ISBN 81-903436-0-3

© 2007, Indian Pharmacopoeia Commission

Application for reproduction should be made to the INDIAN PHARMACOPOEIA COMMISSION

Sector-23, Raj Nagar,

Ghaziabad-201 002

India

Tale: (91-120)–2783401

Fax: (91-120)–2783311

Web-site: [www.ipc.gov.in](http://www.ipc.gov.in) E.mail: [ipclab@vsnl.net](mailto:ipclab@vsnl.net)

**Effective from 31<sup>st</sup> March 2008**

*On behalf of* : GOVERNMENT OF INDIA  
MINISTRY OF HEALTH & FAMILY WELFARE

*Designed, produced & published by* : THE INDIAN PHARMACOPOEIA COMMISSION  
CENTRAL INDIAN PHARMACOPOEIA LABORATORY  
GOVT. OF INDIA, MINISTRY OF HEALTH & FAMILY WELFARE  
SECTOR-23, RAJ NAGAR, GHAZIABAD-201 002.

*Printed by* : NATIONAL INSTITUTE OF SCIENCE COMMUNICATION  
AND INFORMATION RESOURCES (NISCAIR)  
COUNCIL OF SCIENTIFIC & INDUSTRIAL RESEARCH  
PUSA GATE, K. S. KRISHNAN MARG, NEW DELHI – 110012

*Price:* Inland Rs 25000.00  
Foreign - \$ 1000.00  
£ 500.00

## Notices

### Legal Notices

In India, under the Drugs and Cosmetics Act 1940, the current edition of Indian Pharmacopoeia is a book of standards for drugs included therein and the standards as included in the Indian Pharmacopoeia would be official. Also, in several other laws of India, the Indian Pharmacopoeia is recognised as the standard book. It is expedient that enquiry be made in each case in order to ensure that the provisions of any such law are being complied with. In general, the Drugs and Cosmetics Act, 1940, the Narcotic Drugs and Psychotropic Substances Act, 1985, the Poisons Act, 1919 and the rules framed thereunder should be consulted. These statutes empower the Government agencies to enforce the law using this compendium. The monographs of the Indian Pharmacopoeia should be read subject to the restriction imposed by those laws which are applicable.

If considered necessary, the standards included in Indian Pharmacopoeia can be amended and the Secretary-cum-

Scientific Director is authorised to issue such amendments. Whenever such amendments are issued, the Indian Pharmacopoeia would be deemed to have been amended accordingly.

### Patents And Trade Marks

In the Indian Pharmacopoeia, certain drugs and preparations have been included notwithstanding the existence of actual or potential rights in any part of the world. In so far as such substances are protected by Letters Patent their inclusion in the Indian Pharmacopoeia neither conveys, nor implies, licence to manufacture without due permission, authority, or licence from the person or persons in whom such rights exist.

The titles given under the individual monographs are public property. These titles cannot be patented as trade marks and no person is permitted to patent any trade mark devising the root of these titles.

## Preface

The Indian Pharmacopoeia 2007 is published by the Indian Pharmacopoeia Commission (IPC) on behalf of the Government of India, Ministry of Health & Family Welfare. The Government of India constituted the IPC vide their Order No. Z-14012/IPC/CBP/ 2003 dated 22<sup>nd</sup> March 2005. The IPC is a Society under the provisions of the Societies Registration Act, 1860 (Act No. 21 of 1860) for the registration of Literary, Scientific and Charitable Societies. The functioning of the Commission is governed by the provisions of the approved Memorandum of Association, Rules and Regulations of the IPC.

The Commission has set up its headquarters in the campus of the Central Indian Pharmacopoeia Laboratory (CIPL), Sector-23, Raj Nagar, Ghaziabad, UP. The Director CIPL, also functions as the Secretary-cum-Scientific Director of the IPC. The CIPL is the support structure of the Commission.

The Indian Pharmacopoeia is being produced in fulfillment of the requirement in the Drugs and Cosmetics Rules, 1945 of standards of drugs produced in India and in the belief that it contributes significantly in the control of the quality of medicinal products. The standards of this pharmacopoeia are legally enforceable and are intended to help in the licensing and inspection processes.

After independence an Indian Pharmacopoeia Committee was constituted in 1948, which prepared the Pharmacopoeia of India (The Indian Pharmacopoeia) 1955. A Supplement to it was published in 1960. This pharmacopoeia contained western and also traditional drugs, and the same policy continued while preparing the Pharmacopoeia of India 1966 and its 1975 Supplement. In the Pharmacopoeia of India 1985 and its Addenda 1989 and 1991, traditional drugs were not included as publication of a pharmacopoeia of traditional system drugs was taken up separately and only those herbal drugs were included which had supporting definitive quality control standards.

In the period since the publication of the 1985 Edition there has been a significant increase in the range of drugs produced in India. Keeping this in mind the Committee has deleted or added monographs on a system of priorities based on the medical merit and the extent of use of any given article in the country in its following 1996 Edition and its addenda in 2000, 2002, 2005 and one supplement for Veterinary Products in 2002.

The Indian Pharmacopoeia 2007 has been prepared in accordance with the principles and designed plan decided by the Scientific Body of the Indian Pharmacopoeia Commission and completed with untiring efforts made by Commission members and its Secretariat over almost two years.

The Indian Pharmacopoeia 2007 is presented on the user friendly format. The General Notices, Monographs and new testing methods, etc. based on the introduction of advanced

technology and experimental methods widely adopted in India and abroad are being added and updated. The contents of Appendices are revised by and large in consonance with those nowadays adopted internationally for monitoring the quality of the drugs. The monographs of special relevance to the common disease pattern of this region have been given special emphasis by incorporating such medicines.

In addition, emphasis has been put to bring out harmonisation in Appendices to a sound connection between individual monographs and the relevant appendices, and to the standardization of text wording so as to make this edition precise and well structured. The number of monographs in Appendices are expanded further to incorporate the latest technological advances and complies with regulatory requirements. Great efforts have been made to unify the National Drug Standards and to bring them in line with the International Standards progressively by addition of monographs of new drugs and current methodology adopted.

Public Review and Comment Process for Standards Development Related to this edition of the Indian Pharmacopoeia have been given special attention to incorporate comments from stakeholders as shown below:

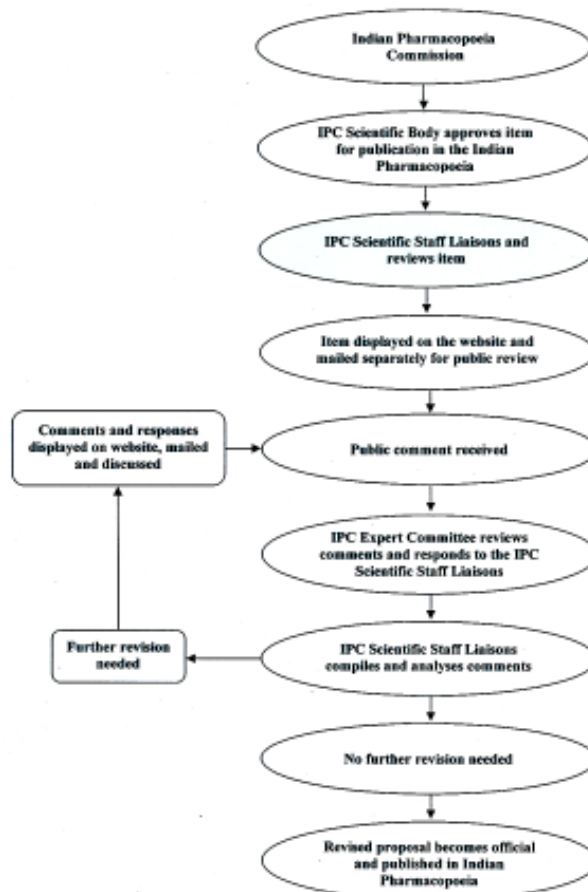

In addition to the traditional way of requesting for comments, the contents of revised appendices and monographs have been publicized on the website of the Indian Pharmacopoeia Commission, aiming at collecting comments widely from various institutions and organizations. All the feedbacks and inputs have been reviewed by the relevant Expert Committee to ensure the feasibility and practicability of the standards and methods revised in this edition of Pharmacopoeia, and ensure that the principle of “openness, justice and fairness” is kept in the process of compiling and editing.

In order to make it easy for reading, understanding and interpreting the content of the Indian Pharmacopoeia 2007

adopts new style of formatting. The improvement of quality in printing and binding makes this edition look more elegant. The Indian Pharmacopoeia 2007 is published in three volumes. It is presumed that the Pharmacopoeia would play a vital role in initiating new prospect for improving the quality of medicines and would also help to accelerate development of Pharma Sector.

The Commission places on record its appreciation of the services of all the persons who have contributed to the production of this compendium.

## Indian Pharmacopoeia Commission

The Indian Pharmacopoeia Commission (IPC) has a three-tier structure comprising of the General Body of 19 members, Governing Body of 8-10 members and Scientific Body of 15-23 members from different related scientific fields; the number of members of the Scientific Body may vary from time to time. The Secretary, Ministry of Health and Family Welfare, is the Chairman and the the Chairman-Scientific Body is the Co-Chairman of the Commission.

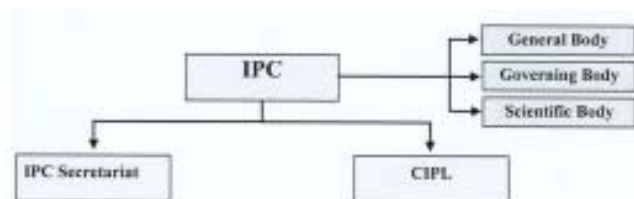

IPC-Structure

The primary responsibility of the Scientific Body is to provide guidelines for Standards development related to the Indian Pharmacopoeia with assistance of its Expert Committees.

The Indian Pharmacopoeia is published in continuing pursuit of the Mission, Vision and Objectives of the IPC.

### Mission

To promote public health in India by bringing out authoritative and officially accepted standard for quality of drugs including active pharmaceutical ingredients, excipients and dosage forms, used by health professionals, patients and consumers.

### Vision

To promote the highest standards of drugs for use in humans and animals within practical limits of the technologies available for manufacture and analysis.

### Objectives

- To develop comprehensive monographs for drugs to be included in the Indian Pharmacopoeia, including active pharmaceutical ingredients, pharmaceutical aids and dosage forms as well as medical devices, and to keep them updated by revision on a regular basis.
- To develop monographs for herbal drugs, both raw drugs and extracts/formulations therefrom.
- To accord priority to monographs of drugs included in the National Essential Drugs List and their dosage forms.
- To take note of the different levels of sophistication in analytical testing/ instrumentation available while framing the monographs.

- To accelerate the process of preparation, certification and distribution of IP Reference Substances, including the related substances, impurities and degradation products.
- To collaborate with pharmacopoeias like the Ph Eur, BP, USP, JP, ChP and International Pharmacopoeia with a view to harmonizing with global standards
- To review existing monographs periodically with a view to deleting obsolete ones and amending those requiring upgradation / revision.
- To organize educational programs and research activities for spreading and establishing awareness on the need and scope of quality standards for drugs and related articles / materials.

### The Governing Body

The composition of the Governing Body is given below:

**Chairman** The Secretary (Health & Family Welfare)  
Government of India  
Ministry of Health & Family Welfare  
Nirman Bhawan  
New Delhi-110011.

(Mr. Prasanna Hota *until 30 October 2006*  
Mr. Naresh Dayal *from 31 October 2007*)

**Co-Chairman** Dr. Nitya Anand  
Ex-Director  
Central Drug Research Institute  
B-62, Nirala Nagar  
Lucknow-226 020.

**Member** The Additional Secretary & Finance Advisor  
Ministry of Health & Family Welfare  
Nirman Bhawan  
New Delhi -110011.

(Dr. Sanjiv Misra *until 30 April 2006*  
Mr. Raghubir Singh *from 30 May 2006*)

**Invitee** The Additional Secretary  
Ministry of Health & Family Welfare  
Nirman Bhawan  
New Delhi-110011.

(Mr. Deepak Gupta)

**Member** The Joint Secretary (Drugs)  
Ministry of Health & Family Welfare,  
Nirman Bhawan  
New Delhi-110011.

(Ms. Rita Teotia *until February 2007*  
Mr. Debasish Panda *from 2 April 2007*)

<i>Member</i>	The Drugs Controller General (I), Directorate General of Health Services Ministry of Health & Family Welfare Nirman Bhawan New Delhi-110011. (Mr. Ashwini Kumar <i>until 31 August 2006</i> Dr. M. Venkateswarlu <i>from 1 September 2006</i> )	<i>Member</i>	The Joint Secretary (Drugs) Ministry of Health & Family Welfare Nirman Bhawan, New Delhi. (Ms. Rita Teatota <i>until February 2007</i> Mr. Debasish Panda <i>from 2 April 2007</i> )
<i>Member</i>	The Director (Drugs) Ministry of Health & Family Welfare Nirman Bhawan New Delhi-110011. (Mr. Rajesh Bhushan <i>until 12 December 2006</i> Dr. Asha Thomas <i>from January 2007</i> )	<i>Member</i>	The Drugs Controller General (I) Directorate General of Health Services Nirman Bhawan, New Delhi. (Mr. Ashwini Kumar <i>until 31 August 2006</i> Dr. M. Venkateswarlu <i>from 1 September 2006</i> )
<i>Member</i>	The Director National Institute of Biologicals B-62, Institutional Area Noida-201 307 (Dr. V. K. Kashyap)	<i>Member</i>	The Director National Institute of Biologicals B-62, Institutional Area Noida-201 307 (Dr. V. K. Kashyap)
<i>Invitee</i>	Dr. P. R. Pabrai Ex-Director, Central Indian Pharmacopoeia Laboratory, C-568, Sarita Vihar New Delhi-110076	<i>Member</i>	The Director Central Drugs Laboratory 3, Kyd Street Kolkata (Dr. P. K. Chatterjee <i>until December 2005</i> )
<i>Member Secretary</i>	The Director Central Indian Pharmacopoeia Laboratory Sector-23, Rajnagar Ghaziabad-201 002 (Dr. G. N. Singh)	<i>Member</i>	The Joint Drugs Controller North Zone Ghaziabad (U.P.) (Dr. S. R. Gupta <i>until 30 September 2005</i> (Mr. N.C. Dhawan <i>from 12 July 2007</i> )
		<i>Member</i>	The Director-Professor Department of Pharmacology Jawaharlal Institute of Post graduate Medical Education and Research Pondicherry-605 006. (Dr. C. Adithan)

### The General Body

The composition of the General Body is as follows:

<i>Chairman</i>	The Secretary (Health & Family Welfare) Government of India Ministry of Health & Family Welfare Nirman Bhawan New Delhi-110011. (Mr. Prasanna Hota <i>until 30 October 2006</i> Mr. Naresh Dayal <i>from 31 October 2007</i> )	<i>Member</i>	Commissioners in charge of Drug Control Administration, Andhra Pradesh (Mr. Ranga Rao)
<i>Member</i>	Dr. Nitya Anand Ex-Director, Central Drug Research Institute B-62, Nirala Nagar Lucknow-226 020.	<i>Member</i>	Commissioners in charge of Drug Control Administration, Maharashtra (Mr. A. Ram Krishnan)
<i>Member</i>	The Additional Secretary & Finance Advisor, Ministry of Health & Family Welfare Nirman Bhawan New Delhi 110011. (Dr. Sanjiv Misra <i>until 30 April 2006</i> Mr. Raghbir Singh <i>from 30 May 2006</i> )	<i>Member</i>	Commissioners in charge of Drug Control Administration, Gujarat (Dr S.P. Adeshara)
		<i>Member</i>	Commissioners in charge of Drug Control Administration, Uttar Pradesh (Mr. Satguru Prasad)
		<i>Member</i>	Commissioners in charge of Drug Control Administration, Orissa (Mr. B. C. Panda)

<i>Member</i>	The Director National Institute of Pharmaceutical Education and Research (NIPER) Sector 67, SAS Nagar Mohali-160 062. (Professor P. Rama Rao)	<i>Member</i>	Professor V. K. Kapoor Ex-Dean and Chairman, Pharmaceutical Sciences, Punjab University 1743, Pushpae Complex Sector 49 B Chandigarh-160 047
<i>Member</i>	The President Indian Drug Manufacturer Association (IDMA) 102-B, Poonam Chambers, 'A' Wing' Dr. Annie Besant Road, Worli Mumbai – 400018 (Mr. Suresh G. Kare)	<i>Member</i>	Professor P. Rama Rao Director National Institute of Pharmaceutical Education and Research (NIPER) Sector 67, SAS Nagar Mohali-160 062.
<i>Member</i>	The President Organizational of Pharmaceutical Producer of India (OPPI) (Shri Ranjit Sahani)	<i>Member</i>	Mr. Parthajyoti Gogoi Director-in-Charge Regional Drugs Testing Laboratory (RDTL) Khana Para, Panjabari, Six mile Guwahati-781 037.
<i>Member</i>	The President Association of Manufacturers of Ayurvedic Medicines (Mr. P. M. Shroff)	<i>Member</i>	Professor Saranjit Singh Professor and Head Department of Pharmaceutical Analysis National Institute of Pharmaceutical Education and Research (NIPER) Sector 67, SAS Nagar Mohali-160 002.
<i>Member Secretary</i>	The Director Central Indian Pharmacopoeia Laboratory Sector-23, Rajnagar Ghaziabad-201 002 (Dr. G. N. Singh)	<i>Member</i>	Dr. V. A. Srinivasan Research Director Indian Immunologicals Ltd. Gachibowli Post Hyderabad-500 032.

### The Scientific Body

The list below includes those members who served during the period

<i>Chairman</i>	Dr. Nitya Anand Ex-Director Central Drug Research Institute B-62, Nirala Nagar Lucknow-226 020	<i>Member</i>	Dr. Prem K. Gupta Ex-Drugs Controller (I) House No. 95 DDA Flats Pocket 'B', Sukhdev Vihar New Delhi -110 025.
<i>Vice-Chairman</i>	Dr. P. R. Pabrai Ex-Director, Central Indian Pharmacopoeia Laboratory, C-568, Sarita Vihar New Delhi-110 076	<i>Member</i>	Dr. S. N. Pal Executive Director HSCC E-6(A), Sector-1, Noida -201 301
<i>Member</i>	Mr. R. S. Iyer M.S.H. Layout, II Stage Anand Nagar Bangalore-560 024.	<i>Member</i>	Dr. D. B. Anantha Narayana Head, Herbal Research Hindustan Lever Research Centre Unilever Research India 64, Main Road, Whitefiled Bangalore- 560 066.
<i>Member</i>	Mr. J. L. Sipahimalani 10-C, Ananta, R. Patel Lane Mumbai-400 026	<i>Member</i>	Mr. Prafull D. Sheth E-256, Greater Kailash-I New Delhi-110 048.



*Member* Dr. V. K. Lal  
College of Pharmacy,  
Institute of Foreign Trade and Management  
Lodhipur-Rajput  
Delhi-Moradabad Raod  
Moradabad. U.P.

*Member* Dr. Anil Paul Kariath  
President – Consulting & Training  
Bangalore Biotech Labs. Pvt. Ltd.  
#49/2, Gubbi Cross, Off Hennur Cross  
Bangalore-560 077.

*Member* Dr. P. G. Shrotriya  
Chief Executive, Elite Pharma Consultants  
11/302 Sea Woods, NRI Complex, Nerul  
Navi Mumbai-400 706.

*Member* Dr. Vinay G Nayak  
President, Tech. Operations  
Watson Pharma Pvt. Ltd.  
Mumbai.

*Member* Mr. Vinod Arora  
Vice-President (Pharma Research)  
Ranbaxy Research Laboratories  
Plot No. 20, Sector 18, Udyog Vihar  
Industrial Area,  
Gurgaon-122 001.

*Member* Dr. T. G. Chandrashekhar  
Vice-President, Global Quality & Analytical  
Research,  
Ranbaxy Research Laboratories,  
Plot No. 20, Sector 18, Udyog Vihar  
Industrial Area  
Gurgaon-122 001

*Member* Dr. K. M. Thomas  
T C/ 10/1013  
CO-OP-Housing Gardens,  
Mannamoola, Peroorkada P O  
Thiruvananthapuram  
Kerala-695005.

*Member* Dr. Hemnalini Kumar  
Director, Bio-Products  
Salesworth India Ltd.  
713 Syndicate Bank Road  
Indira Nagar I Stage  
Bangalore-560 038

*Member* Dr. Anoop Misra  
Former Professor  
All India Institute of Medical Sciences  
Ansari Nagar  
New Delhi.

*Member* Professor Y. K. Gupta  
Head, Department of Pharmacology,  
All India Institute of Medical Sciences  
Ansari Nagar  
New Delhi.

*Invitee* Mr. Gidy Asrani  
President, Pharmacon,  
3, Salmona Ville, North Avenue,  
Santa Cruze,  
Mumbai-400 054.

*Invitee* Dr. Manish Gangrade  
Head - Analytical Development Lab.  
CIPLA Limited  
Mumbai

*Member Secretary* Dr. G. N. Singh  
Director  
Central Indian Pharmacopoeia Laboratory  
Sector-23, Rajnagar  
Ghaziabad-201 002

### **Executive Committee**

Dr Nitya Anand, Dr. M Venkateswarlu\*, Mr. P. D. Sheth, Mr. R. S. Iyer and Dr. G. N. Singh.

\* (Mr. Ashwini Kumar *until 31 August 2006*  
Dr M. Venkateswarlu *from 1 September 2006*)

### **Expert Committees**

#### **Expert Committee on Anti-Retroviral Drugs**

Dr. T. G. Chandrashekhar (*Chair*), Dr. K. M. Thomas, Mr. Antony Raj Gomes, Dr. S. Raghuvveer, Dr. Pramod Dalvi, Dr. Manish Gangrade.

#### **Expert Committee on Anti-Tuberculosis/Anti Asthma Drugs**

Dr. Vinay G Nayak (*Chair*), Professor Saranjit Singh, Dr. Amarjit Singh, Mr. Satyawana Hatte.

#### **Expert Committee on Bioassay, Biostatistics and Toxicology**

Professor P. Rama Rao (*Chair*), Dr. Prakash V. Diwan, Dr. K. M. Chacko.

#### **Expert Committee on Biotechnological and Recombinant DNA Technology Products**

Dr. Anil Paul Kariath (*Chair*), Mr. Ganesh Kumaraj, Mr. S. V. Kotbagi, Dr. Rustom Mody, Dr. Venkata Ramana.

#### **Expert Committee on Blood and Blood Products**

Dr. Prem K. Gupta (*Chair*), Mr. R. Narayana Swamy, Dr. Zareen Bharucha, Dr. Kabita Chatterjee, Mr. Atul Kr. Nasa.

**Expert Committee on Clinical Medicine and Pharmacology**

Professor Y. K. Gupta (*Chair*), Dr. Anoop Misra, Professor P. Rama Rao, Dr. Rama Mukherjee, Dr. R. R. Kasliwal

**Expert Committee on Compounding Pharmacy and Website**

Mr. Parthajyoti Gogoi (*Chair*), Professor Y. Madhusudan Rao, Dr. Prakash V. Diwan, Dr. A. Ramkishan, Dr. R. Sweetly Prem Kumar.

**Expert Committee on Devices and Diagnostics**

Dr. S. N. Pal (*Chair*), Professor Alok Ray, Dr. G. S. Bhuvaneshwar, Sh. M. Mitra.

**Expert Committee on Drug Nomenclature**

Professor V. K. Kapoor (*Chair*), Dr. (Mrs.) Dr Hardeep Wadhwa, Professor Yatendra Kumar.

**Expert Committee on General Analytical Methods**

Dr. T. G. Chandrashekhar (*Chair*), Professor Saranjit Singh, Professor Y. K. Agrawal, Dr. K. M. Thomas, Dr. Milind Joshi.

**Expert Committee on General Policies and Planning**

Mr. Prafull D. Sheth (*Chair*), Mr. B. N. Thakore, Dr. Shailesh Nagarsenker, Professor Y. Madhusudan Rao, Mr. B. K. Sharma.

**Expert Committee on General Chapters and General Format**

Mr. R. S. Iyer (*Chair*).

**Expert Committee on Herbal Products and Crude Drugs**

Dr. D. B. Anantha Narayana (*Chair*), Dr. S. S. Handa, Dr. G. S. Lavekar, Dr. V. K. Lal, Dr. C. K. Katiyar, Dr. Amit Agarwal

**Expert Committee on IP Reference Substances**

Dr. M Venkateswarlu (*Chair*), Dr. P. R. Pabrai, Professor Saranjit Singh.

**Expert Committee on Medicinal Chemicals I**

Dr. P. R. Pabrai (*Chair*), Dr. R. A. Singh, Dr. N. Murugesan, Dr. K. K. Chakraborti, Dr. Ashok Panwar.

**Expert Committee on Medicinal Chemicals II**

Professor V. K. Kapoor (*Chair*), Professor Meenakshi Bajpai.

**Expert Committee on Medicinal Chemicals III**

Mr. J. L. Sipahimalani (*Chair*), Ms Rashida Najmi, Dr. Prashant Dikshit, Ms V. R. Menon.

**Expert Committee on Parenteral Products**

Dr. P. G. Shrotriya (*Chair*), Mr. Sanjit Singh Lamba, Dr. Sumant Baukhandi, Mr. G. S. Bedi, Mr. Satish. R. Kulkarni.

**Expert Committee on Pharmaceutical Dosage Forms**

Mr. Vinod Arora (*Chair*), Professor Arvind K Bansal, Dr Kona Subrahmanya Srinivas, Dr. Kisan B. Chaudhari,

Professor Roop K. Khar, Dr. Praful R. Naik.

**Expert Committee on Publication and Information Technology**

Dr. Hemnalini Kumar (*Chair*), Mr. Parthajyoti Gogoi, Dr. D. B. Anantha Narayana, Mr. Daara B. Patel, Dr. Sanjay Singh.

**Expert Committee on Vaccines and Other Biological Products**

Dr. V. A. Srinivasan (*Chair*), Dr. A. K. Tahlan, Dr. Surinder Singh, Dr. Rishendra Verma, Dr. S. S. Jadhav.

**IPC Secretariat**

An active and effective support to the Expert Committees is provided by the following staff members from CIPL.

**Director CIPL**

Dr. G. N. Singh Secretary-cum-Scientific Director

**Research & Development Division**

The major activities related to formatting, reviewing and liaisons for Standard Development is performed by following:

Dr. Raman Mohan Singh (Head), Dr. S. C. Mathur, Mr. Dinesh Kr. Sharma, Mr. Pawan Kr. Saini, Mr. Munendra Kr. Poonia and Km. Anu Somvanshi.

**Pharmacology & Microbiology Division**

The matters related to biologicals is taken care of by following:

Dr. Jai Prakash (Head), Mr. Surendra Kr. Talwar, Mr. Charan Singh Nivoria, Mr. Alok Sharma, Mr. Manoj Kr. Pandey and Mr. Satyapal Singh.

**Publication Division**

The issues related to publication, sales and marketing is looked after by following:

Mr. K. K. Singh (Head), Mr. Udai Pal and Mr. Sudhakar Singh.

**Scientific, Administrative and Miscellaneous Support**

Support provided in Scientific and Administrative matters by following is appreciable:

Mrs. Savita Shukala, Ms. Sangeeta Bhatnagar and Mr. Satyaprakash Tyagi

Mr. R. C. Saxena, Mr. Tribhuvan Nautiyal, Mr. I. J. S. Oberoi and Mr. H. S. Rana.

**Other Participants**

Participants other than those mentioned above who assisted in the work relating to preparation of this Pharmacopoeia are given below:

Dr. Abraham Patani, Dr. A. K. Singh, Mr. Arvind Kukrety, Dr. A. Ram Krishan, Mrs. Annie Pillai, Mr. Arun Mendiratta, Mr. Arun Khosla, Mr. Atul Kumar Sharma, Ms. Ayesha Patial, Dr.

A. Koteeswaran, Mr. Atma Kuri, Mr. Alok Upadhyaya, Mr. Alok Kumar Yadav, Ms. Aarti Sharma, Dr. Anil Thakan, Mr. Anil Rana, Mr. Ashish Pargaonkar, Ms. Ashwini Oza, Dr. Anil Kanaujia, Mr. Ashish Suthar, Mr. Anand S. Mayachari, Mr. B. N. Singh, Dr. B. Murlai Manohar, Mr. B. Murali, Ms. B. Gayatri, Dr. B. K. Tiwari, Dr. Bhaswat Chaudhary, Mr. B. R. S. Rao, Mr. B. Venugopal, Mr. Bhupendra Shah, Dr. C. P. Gupta, Ms. C. L. Prathima, Ms. Celina D'suja, Dr. C. Venkateswara Rao, Dr. Charles Rupprecht, Mr. Dattahari Dash, Mr. Deep Chandra Upadhyaya, Mr. D. K. Sood, Dr. D. Roy, Dr. D. P. Ghosh, Mr. D. K. Jain, Mr. D. P. Singh, Mr. D. K. Shringi, Mr. Devender Berthwal, Mr. Deepak Mhasawade, Mr. Deepak Sharma, Mr. Dharmendra Kumar Pandey, Dr. Ferguson, Dr. G. Kamraj, Dr. Gajendra Singh, Mrs. Geetanjali, Mr. G. Prabhakar Roa, Dr. George Patani, Dr. G. S. Dhamdhare, Dr. G. S. Reddy, Dr. Girish Sahni, Dr. Gyanesh Shukla, Dr. G. Trimurtulu, Dr. G. D. Bagchi, Dr. H. Meer Azad, Mr. Harjeet Aggarwal, Dr. Hau-Pong, Ms. Ishani Kapila, Mr. J. B. Mathur, Dr. Janardan Singh, Dr. Jitendra Kumar, Dr. John Furesz, Dr. John Petricciani, Dr. Jen Ron-Chiang, Dr. Joachim Hombach, Mr. K. Bhargava, Dr. K. R. Mani, Dr. K. N. Reddy, Mr. K. P. Prasanna, Dr. K. Ananda Rao, Dr. Koprowski, Mr. Kishan B. Chaudhary, Dr. K. V. Jogi, Dr. K. Shivram, Dr. K. Suresh, Dr. Kulvinder Singh Saini, Mr. K. Rama Rao, Dr. Kiran M. Brdee, Dr. L. R. Sood, Dr. L. Rajendra, Mr. Madan Mohan Prasad, Mrs. Madhu Bala Kapoor, Dr. Manoj Patel, Dr. M. Rajani, Mr. M. L. Suryanarayana, Dr. M. M. Gupta, Dr. M. Murali, Mr. Mohd. Asif, Ms. Nita Kejrewal, Dr. N. Gopalan, Mr. Niranjana S. Kanaki, Ms. Neelam Tarani, Mr. Naresh Soni, Mr. Om Prakash, Dr. P. V. Kanitkar, Mr. Praful Lahorkar, Dr. Praveen Tiwari, Ms. Premlata, Dr. Pele Chong, Ms. P. Lakshmi, Dr. P. S. Rao, Sh. R. Raghunandan, Dr. Rahul Singh, Mr. Rajendra M. Dobriyal, Mr. R. P. Yjuurvedi, Mr. R. S. Bhakuni, Mr. Ramesh Dhar, Mrs. Ritu Tiwari, Dr. Rajashree Rane, Mrs. Rashmi Srivastava, Dr. R. K. Singh, Professor R. L. Khosa, Mr. S. Kanna Babu, Mr. Shantanu Chobhe, Mr. Supratika Tripathi, Mr. Sanjay Kumar, Mr. S. Z. Bharuch, Mr. Shishir Jaipuria, Mr. Sacchidanandan, Dr. S. Natarajan, Dr. Suresh Kumar, Dr. Sheetal Anandjiwala, Dr. Sushma Srivastava, Professor S. S. Agarwal, Dr. S. P. S. Khanuja, Dr. Sunil Gairola, Dr. S. R. Desai, Dr. Suresh Jadhav, Professor Tom Barrett, Dr. Scott Halstead, Mr. S. K. Malik, Mr. Sanjeev Kumar, Mr. Sanjeev Verma, Mr. Sunil Goel, Mr. Shib Nath Nanergei, Dr. Shrenik Gangwal, Dr. Shri Prakash, Ms. Sujata Sen, Ms. Shweta Gulati, Mr. Sanjay Srivastava, Mr. Sanjiv Kumar, Dr. Sangeeta Bhaskar, Mr. Satish Kulkarni, Dr. Santosh Ghadge, Dr. Shankar Chinchkar, Professor S. K. Gupta, Ms. Vandana, Dr. Shivraj Yadav, Dr. Sanjeev Wadhwa, Mrs. Subhra Samadtar, Mr. Thakur Sher Singh, Dr. S. K. Vyas, Mr. Vikas Dogar, Mr. Vikas Chhawchharia, Mr. Vivek Bansal, Mr. Vivek Jadav, Mr. Vivek Dhariwal, Mr. Vijay Kshrisagar, Ms. Veenu Tyagi, Mr. V. N. Phatak, Dr. Vinayak Naik, Ms. Vandana Aneja, Mr. Vinod Saini, Dr. V. Chauhan, Dr. Vinod Kumar Singh, Dr. Y. K. S. Rathore, Dr. Y. Udaya Bhaskar Rao, Mr. Yogesh Biradar.

## Acknowledgements

In preparing this Pharmacopoeia, the British Pharmacopoeia, The European Pharmacopoeia, the United States Pharmacopoeia and the National Formulary, the International Pharmacopoeia, the Chinese Pharmacopoeia, the Pharmacopoeia of Japan, the Pharmaceutical Codex, the Merck Index and the standards published by the Bureau of Indian Standards have been consulted. The Indian Pharmacopoeia Commission expresses its thanks to the Commissions, Committees, Conventions or other organizations under whose authority these publications have been issued. At the same time, the Commission wishes to state that if any errors have inadvertently crept into the present compilation with regard to the statements of quantities or strengths or making quotations, such mistakes are in no way attributable to any of the publications mentioned above or to the authorities issuing them.

Close co-operation has continued with specialists from many organisations in India and abroad. These include the Central Indian Pharmacopoeia Laboratory, Ghaziabad; Central Drugs Laboratory, Kolkata; Central Drugs Testing Laboratory, Chennai; Central Drugs Laboratory, Kasauli, All India Institute of Medical Sciences; Indian Veterinary Research Institute, Izzatnagar; Indian Immunological Ltd., Hyderabad; Organisation of Pharmaceutical Producers of India (OPPI), Mumbai; Bee Pharma Laboratories, Mumbai; Ranbaxy Research Laboratories, Gurgaon; Baxter (India) Pvt. Ltd., Gurgaon; the United States Pharmacopoeia Convention, USA; the British Pharmacopoeia Commission, London and the World Health Organization (WHO), Geneva.

The assistance provided by the Indian Drug Manufacturer's Association (IDMA), Mumbai, specially through its Technical Sub-Committees, its Secretary-General and President in arranging meetings and in enhancing visibility of the IP from time to time is noteworthy.

Special mention is being made of the permission granted at the time of preparing the preceding edition by the Controller of Her Majesty's Stationery Office (HMSO), London for reproduction of Infra-red Reference Spectra of certain drug substances from the British Pharmacopoeia. Infra-red Reference Spectra of other compounds have been drawn by Ranbaxy Laboratories Ltd. and the Central Indian Pharmacopoeia Laboratory, Ghaziabad from reference materials graciously made available by a number of pharmaceutical manufacturers in the country.

The cooperation extended by the United States Pharmacopoeia Convention, USA, the British Pharmacopoeia Commission and the industry in incorporating new features in this edition is gratefully acknowledged.

The structural formulae of the organic molecules forming the subject matter of the monographs of all drug substances were drawn with the facility provided by NIPER, Mohali. Professor V K Kapoor along with his associate Mr Gaurav Sharma and Dr Nitya Anand have been entirely responsible for ensuring the accuracy of the structures and the chemical names; the Commission acknowledges their valuable contribution in this respect.

The Commission is greatly indebted to the members of the Scientific Body and the various experts in the industry for their valuable and enthusiastic assistance in preparing this edition. The scientific inputs from them and the co-operation and co-ordination of a high order among them is deeply appreciated.

The Commission is especially indebted to three individuals who must be named because without their combined dedication, diligence and sense of public service, this enterprise would not have been completed in the limited time that was available. Mr J L Siphahimalani, Ms V R Menon and Mr R S Iyer with their professional knowledge, inputs and meticulous attention to detail reviewed all the monographs and general chapters and put the manuscripts into their present new shape. Thanks are due to them for shouldering the major responsibility of preparing this edition.

Dr Nitya Anand, Chairman, IP Commission was a source of immense inspiration and in his personal capacity motivated one and all in their efforts to give of their best to the creation of this compendium. The Commission is grateful to him.

Secretarial assistance of a high order was provided by IPC Secretarial staff, special mention is the devotion to duty exhibited by Dr. Raman Mohan Singh, Dr. S. C. Mathur, Mr. Dinesh Kr. Sharma and Mr. Pawan Kr. Saini in the work of careful scrutiny, review and correction of the manuscripts at various stages. In particular, Mr. Munendra Kumar Poonia as the Computer Assistant (Secretarial) with IPC rendered valuable service in typing and formatting of each and every monograph, the appendices and other texts. The Commission records its appreciation of his contribution.

The facility provided by Mr. Chandru Sahani of Clanzid for containerization of Reference Substances by means of IFRESS is highly appreciated.

The Commission wishes to record its deep appreciation of the inputs by the staff of the National Institute of Science Communication and Information Resources (NISCAIR), particularly Mr. Pradeep Banarjee, Mr. Kaushal Kishore, Smt. Supriya Gupta, Mr. K. B. Nagpal, Mr. Pankaj Gupta, Mr. Shiv Kumar and Mr. I. K. Sehgal in bringing out this publication.

# Introduction

This new edition of the Indian Pharmacopoeia entitled Indian Pharmacopoeia 2007 has been prepared by the Indian Pharmacopoeia Commission (IPC) in accordance with a plan and completed through the untiring efforts of its members and its Secretariat over a period of about two years. This is the fifth edition of the Indian Pharmacopoeia after Independence. It supersedes the 1996 edition but any monograph of the earlier edition that does not figure in this edition continues to be official as stipulated in the Second Schedule of the Drugs and Cosmetics Act, 1940.

## Presentation

The Indian Pharmacopoeia 2007 is presented in three volumes. Volume 1 contains the Notice, Preface, the structure of the IPC, Acknowledgements, Introduction, and the General Chapters. Volume 2 deals with the General Monographs on Drug Substances, Dosage Forms and Pharmaceutical Aids (A to M). Volume 3 contains Monographs on Drug Substances, Dosage Forms and Pharmaceutical Aids (N to Z) followed by Monographs on Vaccines and Immunosera for Human use, Herbs and Herbal products, Blood and blood-related products, Biotechnology products and Veterinary products.

The scope of the Pharmacopoeia has been extended to include products of biotechnology, indigenous herbs and herbal products, viral vaccines and additional antiretroviral drugs and formulations, inclusive of commonly used fixed-dose combinations. Standards for veterinary drugs and products that were published as a Supplement to the previous edition of the Indian Pharmacopoeia now form an integral part of this compendium.

## Format

In an effort to make the pharmacopoeia more user-friendly, a drastic change has been made in the design of the texts of the monographs and of the test methods. Cross-referencing has been avoided to make each monograph complete in itself thus making it convenient to the analyst performing the tests and to the ones checking the results of analyses. The multiplicity of fonts in the texts that was a feature of earlier editions has been done away with making it easier to read the contents and ensuring uniformity of presentation of the subject matter.

## Basis of Pharmacopoeial Requirements

As in the past, this compendium provides a publicly available statement concerning the quality of a product that can be expected and demonstrated at any time throughout the accepted shelf-life of the article. The standards laid down

represent the minimum with which the article must comply and it is incumbent on the manufacturer to ensure that the article is manufactured in accordance with Good Manufacturing Practices. It is essential that sufficiently stringent limits are applied at the time of release of a batch of a material or product so that the pharmacopoeial standards are met until its expiry date under the storage conditions specified.

It must be noted that a valid interpretation of any requirement of the Pharmacopoeia should be done in the context of the monograph as a whole, the relevant general monograph, where appropriate, the specified tests and methods of analysis including any reference to the relevant General Notices. Familiarity with the General Notices will facilitate the correct application of the requirements.

## Changes

Keeping in view the essential nature of the pharmacopoeia as a compilation of drug quality standards and test methods for determining compliance with such standards, information on category of a drug, dosage and usual available strengths of dosage forms has been omitted. Solubility, which has either to be included in the informatory section of a monograph, is now a part of a section listing the solubilities of all active pharmaceutical ingredients and pharmaceutical aids. This information has been given only as an aid for the additional characterization of an article and not as a standard.

As further simplification of labelling of medicines, the main titles for monographs of formulated preparations are given in the shorter form in terms of the active moiety rather than of the salt (with few exceptions).

Labelling and storage are featured at the end of a monograph more as recommendations than as requirements except where a specific label statement is necessary for an analyst to determine compliance or a storage condition is essential for preserving the quality of an article.

Classical chemical tests for identification of an article have been almost eliminated and the more specific infrared and ultraviolet spectrophotometric tests have been given. The concept of relying on published infrared spectra as a basis for identification has been continued.

The use of chromatographic methods has been greatly extended to cope with the need for more specificity in assays and in particular, in assessing the nature and extent of impurities in ingredients and products.

The test for pyrogens involving the use of test animals has been virtually eliminated. The test for bacterial endotoxins introduced in the previous edition is now applicable to more



items. The test for abnormal toxicity is now confined to certain vaccines.

## General Chapters

Volume 1 is devoted mainly to test methods that are applicable to all the articles of the pharmacopoeia and general information pertaining to the quality requirements of medicinal substances. It also includes reference data such as reference spectra, typical chromatograms etc. The test methods reflect the sophistication of analytical methodology and instrumentation.

Analytical methods are in general in harmony with those adopted internationally for monitoring the quality of drugs. The steps taken for harmonization have been initiated by the need to cope with the increasing demand for drugs manufactured in the country to globally accepted standards.

A vastly enlarged section on Containers for pharmaceutical products is an indication of the widespread use of plastics as the material of choice for packaging. The evaluation of different types of plastics has been dealt with in some detail.

The trend towards controlling the microbial quality of all medicinal products has been recognized and a start has been made to apply limits of bacterial contamination even of products for oral administration and topical application so that adequate controls are exercised by manufacturers by the adoption of good manufacturing practices.

## General Monographs

The General Monographs for dosage forms of active pharmaceutical ingredients (APIs) are grouped together at the beginning of Volume 2. They are followed by the monographs for the APIs, pharmaceutical aids and individual dosage forms, all in alphabetical order. Monographs for other articles of a special nature such as vaccines and immunosera for human use, herbs and herbal products, blood and blood related products, biotechnology products and veterinary products are given in separate sections in Volume 3.

A list of items not included in the 1996 edition of the Indian Pharmacopoeia and its addenda but added in this edition is given below:

### Admissions

#### Monographs

Abacavir Oral Solution

Abacavir Tablets

Abacavir and Lamivudine Tablets

Abavavir, Lamivudin and Zidovudine Tablets

Acarbose

Acarbose Tablets

Aceclofenac

Aceclofenac Tablets

Ambroxol Hydrochloride

Amlodipine Besilate

Amlodipine Tablets

Amoxycillin and Potassium Clavulanate Injection

Amoxycillin and Potassium Clavulanate Oral Suspension

Amoxycillin and Potassium Clavulanate Tablets

Amphotericin B Injection

Arteether

Artemether

Artimisinin

Atorvastatin Calcium

Atorvastatin Tablets

Azathioprine

Azathioprine Tablets

Azithromycin

Azithromycin Capsules

Azithromycin Oral Suspension

Azithromycin Tablets

Baclofen

Baclofen Oral Solution

Baclofen Tablets

Benzyl Alcohol

Betahistine Hydrochloride

Betahistine Tablets

Betamethasone Eye Drops

Bleomycin Injection

Bronopol

Budesonide

Calcium Stearate

Capreomycin Sulphate

Capreomycin Injection

Carbomers

Cefaclor

Cefaclor Capsules

Cefaclor Oral Suspension

Cefaclor Sustained-release Tablets

Cefoperazone Injection

Cefoperazone Sodium

---

Ceftriaxone Injection	Fluticasone Propionate Powder for Inhalation
Ceftriaxone Sodium	Formoterol Fumarate and Budesonide Powder for Inhalation
Cefuroxime Axetil	Formoterol Fumarate Dihydrate
Cefuroxime Axetil Tablets	Gatifloxacin
Cetirizine Hydrochloride	Gatifloxacin Infusion
Cetirizine Tablets	Gatifloxacin Tablets
Chlorhexidene Acetate	Glipizide
Chlorhexidene Hydrochloride	Glipizide Tablets
Chlorobutanol	2-Deoxy-D-Glucose
Ciclesonide	Imipenem
Ciclesonide Inhalation	Imipenem and Cilastatin Injection
Ciprofloxacin Eye Drops	Ipratropium Bromide
Clarithromycin	Irinotecan Hydrochloride Trihydrate
Clarithromycin Tablets	Irinotecan Injection
Clobazam	Lamivudine and Tenofovir Tablets
Clobazam Capsules	Lamivudine, Nevirapine and Stavudine Dispersible Tablets
Clomipramine Capsules	Lamotrigine
Clomipramine Hydrochloride	Lamotrigine Dispersible Tablets
Clonazepam	Levocetirizine Hydrochloride
Clonazepam Injection	Levocetirizine Tablets
Croscarmellose Sodium	Levofloxacin Hemihydrate
Crospovidone	Levofloxacin infusion
Dicyclomine Injection	Levofloxacin Tablets
Didanosine Capsules	Lisinopril
Diethylphenyl Acetamide	Lisinopril Tablets
Diethyl Phthalate	Lopinavir and Ritonavir Capsules
Docusate Sodium	Lopinavir and Ritonavir Tablets
Domperidone Maleate	Losartan Potassium
Domperidone Tablets	Losartan Tablets
Donepezil Hydrochloride	Meropenem
Donepezil Tablets	Meropenem Injection
Emtricitabine	Nandrolone Phenylpropionate Injection
Emtricitabine Capsules	Nelfinavir Mesylate Oral Powder
Ethambutol and Isoniazid Tablets	Nifedipine Sustained-release Tablets
Ethylcellulose	Norfloxacin Eye Drops
Etoposide	Ofloxacin
Etoposide Capsules	Ofloxacin Infusion
Etoposide Injection	Ofloxacin Ophthalmic Solution
Fluticasone Propionate	Ofloxacin Tablets
Fluticasone Propionate Inhalation	Olanzapine

Olanzapine Tablets	Tenofovir and Emtricitabine Tablets
Oseltamivir Phosphate	Tiotropium Bromide Monohydrate
Oseltamivir Capsules	Tiotropium Powder for Inhalation
Oseltamivir Oral Suspension	Tizanidine Hydrochloride
Paclitaxel	Tizanidine Tablets
Paclitaxel Injection	Topotecan Hydrochloride
Potassium Clavulanate	Topotecan Injection
Potassium Clavulanate Diluted	Vinorelbine Tartrate
Prednisolone Sodium Phosphate	Vinorelbine Injection
Prednisolone Sodium Phosphate Injection	Zidovudine Injection
Prothionamide	<b>Biotechnology Products</b>
Prothionamide Tablets	Erythropoietin Concentrated Solution
Rabeprazole Sodium	Filgrastim Concentrated Solution
Rabeprazole Tablets	Interferon Alfa-2 Concentrated Solution
Ramipril	Streptokinase Bulk Solution
Ramipril Capsules	<b>Blood and Blood Products</b>
Ramipril Tablets	Anti-A Blood Grouping Serum
Rifampicin Tablets	Anti-B Blood Grouping Serum
Rifampicin and Isoniazid Tablets	Anti-D (Rh <sub>0</sub> ) Immunoglobulin
Rifampicin, Isoniazid and Ethambutol Tablets	Anti-D Immunoglobulin for Intravenous Use
Rifampicin, Isoniazid and Pyrazinamide Tablets	Anti-Human Globulin Serum
Rifampicin, Isoniazid, Pyrazinamide and Ethambutol Tablets	Blood Grouping Serums Anti-D, Anti-C, Anti-E, Anti-c, Anti-e
Purified Rayon	Cryoprecipitated Antihæmophilic Factor
Ritonavir Capsules	Fibrin Sealant Kit
Ritonavir Tablets	Human Coagulation Factor IX
Rosiglitazone Maleate	Human Coagulation Factor VII
Rosiglitazone Tablets	Human Coagulation Factor VIII (r DNA)
Rosuvastatin Calcium	Human Normal Immunoglobulin for Intravenous Use
Rosuvastatin Tablets	Human Prothrombin Complex
Roxithromycin	Plasma for Fractionation
Roxithromycin Tablets	Platelet Concentrate
Salmeterol Xinafoate	<b>Herbs and Herbal Products</b>
Salmeterol and Fluticasone Propionate Inhalation	Amalaki
Salmeterol and Fluticasone Propionate Powder for Inhalation	Amra
Saquinavir Mesylate Tablets	Arjuna
Secnidazole	Artemisia
Secnidazole Tablets	Bhibhitaki
Stavudine Oral Solution	Bhringraj
Tenofovir Disoproxil Fumarate	Coleus
Tenofovir Disoproxil Fumarate Tablets	



Gokhru	Hepatitis A (Inactivated) and Hepatitis B (rDNA) Vaccine (Adsorbed)
Gudmar	Inactivated Influenza Vaccine (Split Virion)
Guduchi	Inactivated Influenza Vaccine (Surface Antigen)
Haritaki	Inactivated Influenza Vaccine (Whole Virion)
Kunduru	Measles and Rubella Vaccine (Live)
Kutki	Measles, Mumps and Rubella Vaccine (Live)
Lasuna	Meningococcal Polysaccharide Vaccine
Manjistha	Mumps Vaccine (Live)
Maricha	Pertussis Vaccine
Pippali Large	Pneumococcal Polysaccharide Vaccine
Pippali Small	Poliomyelitis Vaccine (Inactivated)
Punarnava	Rubella Vaccine (Live)
Sarpagandha	Tick-Borne Encephalitis Vaccine (Inactivated)
Shatavari	Typhoid (Strain Ty 21a) Vaccine, Live (Oral)
Shati	Typhoid Polysaccharide Vaccine
Tulasi	Typhoid Vaccine (Freeze Dried)
	Varicella Vaccine, Live

#### **Vaccines for Human Use**

Adsorbed Diphtheria, Tetanus and Hepatitis B (rDNA) Vaccine  
 Adsorbed Diphtheria, Tetanus, Pertussis (Acellular Component) and Haemophilus Type B Conjugate Vaccine  
 Adsorbed Diphtheria, Tetanus, Pertussis (Acellular Component) and Hepatitis B (rDNA) Vaccine  
 Adsorbed Diphtheria, Tetanus and Pertussis (Acellular Component), Inactivated Poliomyelitis Vaccine and Haemophilus Type B Conjugate Vaccine  
 Adsorbed Diphtheria, Tetanus, Pertussis and Poliomyelitis (Inactivated) Vaccine  
 Adsorbed Diphtheria, Tetanus, Pertussis (Acellular Component) and Inactivated Poliomyelitis Vaccine  
 Adsorbed Diphtheria, Tetanus, Pertussis, Poliomyelitis (Inactivated) and Haemophilus Type B Conjugate Vaccine  
 Adsorbed Pertussis Vaccine (Acellular Component)  
 Adsorbed Pertussis Vaccine (Acellular, Co-purified)  
 Diphtheria and Tetanus Vaccine (Adsorbed) for Adults and Adolescents  
 Diphtheria Vaccine (Adsorbed)  
 Diphtheria, Tetanus, Pertussis (Whole Cell) and Haemophilus Type B Conjugate Vaccine (Adsorbed)  
 Diphtheria, Tetanus, Pertussis (Whole Cell), Hepatitis B (rDNA) and Haemophilus Type B Conjugate Vaccine (Adsorbed)  
 Diphtheria, Tetanus, Pertussis (Whole Cell) and Hepatitis B (rDNA) Vaccine (Adsorbed)  
 Haemophilus Type b Conjugate Vaccine

#### **Veterinary Monographs**

Clostridium Multicomponent Vaccine, Inactivated  
 Inclusion Body Hepatitis (IBH) Vaccine, Inactivated  
 Infectious Coryza Vaccine  
 Ivermectin  
 Ivermectin Injection  
 Laryngotracheitis Vaccine, Live  
 Peste Des Petitis Ruminants Vaccine, Live

A list of items included in the 1996 edition of the Indian Pharmacopoeia but deleted in this edition is given below

#### **Omissions**

Astemizole  
 Astemizole Tablets  
 Diazepam Capsules  
 Fenfluramine Hydrochloride  
 Fenfluramine Hydrochloride Tablets  
 Pectin  
 Phenformin Hydrochloride  
 Phenformin Hydrochloride Tablets  
 Phthalysulphathiazole  
 Phthalysulphathiazole Tablets  
 Succinylsulphathiazole  
 Succinylsulphathiazole Tablets  
 Sulphacetamide Sodium Eye Ointment

**INDIAN  
PHARMACOPOEIA  
2007**

**Volume 1**

**THE INDIAN PHARMACOPOEIA COMMISSION  
GHAZIABAD**

# INDIAN PHARMACOPOEIA 2007

## CONTENTS

### VOLUME 1

Notices	....
Preface	....
Indian Pharmacopoeia Commission	....
Acknowledgements	....
Introduction	....
General Chapters	....

### VOLUME 2

General Notices	....
General Monographs on Dosage Forms	....
Monographs on Drug substances, Dosage forms and Pharmaceutical aids Monographs A to M	....

### VOLUME 3

General Notices	....
Monographs on Drug substances, Dosage forms and Pharmaceutical aids Monographs N to Z	....
Monographs on Vaccines and Immunosera for Human Use	....
Monographs on Herbs and Herbal Products	....
Monographs on Blood and Blood-related Products	....
Monographs on Biotechnology Products	....
Monographs on Veterinary Products	....
Index	....

# Volume 1

## CONTENTS

Notices	....
Preface	....
Indian Pharmacopoeia Commission	....
Acknowledgements	....
Introduction	....
General Chapters	....

## GENERAL CHAPTERS

1. General Notices	....
2. Test Methods	....
2.1. Apparatus	....
2.2. Biological Methods	....
2.3. Chemical Methods	....
2.4. Physical and Physicochemical Methods	....
2.5. Pharmaceutical Methods	....
2.6. Tests on Herbal Products	....
2.7. Tests on Vaccines	....
2.8. Tests on Blood and Blood-related Products	....
3. Reference Data	....
4. Reagents and Solutions	....
5. General Texts	....
6. Containers	....
7. Tables	....

# 1. GENERAL NOTICES

General Statements	....
Name	....
Official and Official Articles	....
Official Standards	....
Added Substances	....
Alternative Methods	....
Meanings of Terms	....
Provisions Applicable to Monographs and Test Methods	....
Expression of Contents	....
Expression of Concentrations	....
Abbreviated Statements	....
Weights and Measures	....
Monographs	....
General Monographs	....
Production	....
Manufacture of Drug Products	....
Excipients	....
Individual Monographs	....
Titles	....
Chemical Formulae	....
Atomic and Molecular Weights	....
Definitions	....
Statement of Contents	....
Descriptions	....
Identification	....
Tests and Assay	....
Tests	....
Other tests	....
Limits	....
Quantities	....

Apparatus	....
Reagents and Solutions	....
Indicators	....
Reference Substances	....
Tests Animals	....
Calculation of Results	....
Storage	....
Storage Containers	....
Labelling	....

## General Notices

### General Statements

The General Notices provide the basic guidelines for the interpretation and application of the standards, tests, assays, and other specifications of the Indian Pharmacopoeia (IP), as well as to the statements made in the monographs and other texts of the Pharmacopoeia.

A monograph is to be constructed in accordance with any general monograph or notice or any appendix, note or other explanatory material that is contained in this Pharmacopoeia and that is applicable to that monograph. All statements contained in the monograph, except where a specific general notice indicates otherwise and with the exceptions given hereafter, constitute standards for the official articles. An article is not of pharmacopoeial quality unless it complies with all of the requirements stated.

Exceptions to the General Notices do exist, and where they do, the wording in the individual monograph or an appendix takes precedence and specifically indicates directions or the intent. Thus, the specific wording of standards, tests, assays and other specifications is binding wherever deviations from the General Notices exist. Likewise, where there is no specific mention to the contrary, the General Notices apply.

**Name.** The full name or title of this book, including addenda thereto, is Indian Pharmacopoeia 2007, abbreviated to IP 2007. In the texts, the term "Pharmacopoeia" or "IP" without qualification means the Indian Pharmacopoeia 2007 and any addenda thereto.

**Official and Official Articles.** The word 'official' wherever used in this Pharmacopoeia or with reference thereto, is synonymous with 'pharmacopoeial', with 'IP' and with 'compendial'. The designation IP in conjunction with the official title on the label of an article is an indication that the article purports to comply with IP standards.

The following terms are used where the articles for which monographs are provided are to be distinguished.

An official substance is a single drug or a drug entity or a pharmaceutical aid for which the monograph title includes no indication of the nature of a dosage form.

An official preparation is a drug product (dosage form) and is the finished or partially finished preparation or product of one or more official substances formulated for use on the patient.

An article is an item for which a monograph is provided, whether an official substance or an official preparation.

**Official Standards.** The requirements stated in the monographs apply to articles that are intended for medicinal

use but not necessarily to articles that may be sold under the same name for other purposes.

The active pharmaceutical ingredients (drug substances), excipients (pharmaceutical aids), pharmaceutical preparations (dosage forms) and other articles described in the monographs are intended for human and veterinary use (unless explicitly restricted to one of these uses).

The requirements given in the monographs are not framed to provide against all possible impurities, contaminants or adulterants; they provide appropriate limitation of potential impurities only.

A preparation must comply throughout the shelf-life assigned to it by the manufacturer; for opened or broached containers the maximum period of validity for use may sometimes be stated in the individual monograph. Nevertheless, the responsibility for assigning the period of validity shall be with the manufacturer.

**Added Substances.** An official substance, as distinguished from an official preparation, contains no added substances except when specifically permitted in the individual monograph. Unless otherwise specified in the individual monograph, or elsewhere in the General Notices, suitable substances may be added to an official preparation to enhance its stability, usefulness or elegance, or to facilitate its preparation. Such auxiliary substances shall be harmless in the amounts used, shall not exceed the minimum quantity required to provide their intended effect, shall not impair the therapeutic efficacy or the bioavailability or safety of the preparation and shall not interfere with the tests and assays prescribed for determining compliance with the official standards. Particular care should be taken to ensure that such substances are free from harmful organisms. The freedom to the manufacturers to add auxiliary substances imposes on them the responsibility of satisfying the licensing authorities on the purpose of the addition and the innocuity of such substances.

**Alternative Methods.** The tests and assays described are the official methods upon which the standards of the Pharmacopoeia are based. Alternative methods of analysis may be used for control purposes, provided that the methods used are shown to give results of equivalent accuracy and enable an unequivocal decision to be made as to whether compliance with the standards of the monographs would be achieved if the official methods were used. Automated procedures utilising the same basic chemistry as the test procedures given in the monograph may also be used to determine compliance. Such alternative or automated procedures must be validated.

In the event of doubt or dispute, the methods of analysis of the Pharmacopoeia are alone authoritative and only the result obtained by the procedure given in this Pharmacopoeia is conclusive.



### Meanings of Terms

**Alcohol.** The term “alcohol” without qualification means ethanol (95 per cent). Other dilutions of ethanol are indicated by the term “alcohol” or “alcohol” followed by a statement of the percentage by volume of ethanol (C<sub>2</sub>H<sub>6</sub>O) required.

**Desiccator.** A tightly-closed container of suitable size and design that maintains an atmosphere of low moisture content by means of silica gel or phosphorus pentoxide or other suitable desiccant.

**Drying and ignition to constant weight.** Two consecutive weighings after the drying or igniting operations do not differ by more than 0.5 mg, the second weighing following an additional period of drying or of ignition respectively appropriate to the nature and quantity of the residue.

**Ethanol.** The term “ethanol” without qualification means anhydrous ethanol or absolute alcohol.

**Filtration.** Unless otherwise stated, filtration is the passing of a liquid through a suitable filter paper or equivalent device until the filtrate is clear.

**Freshly prepared.** Made not more than 24 hours before it is issued for use.

**Label.** Any printed packing material, including package inserts that provide information on the article.

**Negligible.** A quantity not exceeding 0.50 mg.

**Solution.** Where the name of the solvent is not stated, “solution” implies a solution in water. The water used complies with the requirements of the monograph on Purified Water. The term ‘distilled water’ indicates Purified Water prepared by distillation.

**Temperature.** The symbol ° used without qualification indicates the use of the Celsius thermometric scale.

**Water.** If the term is used without qualification it means Purified Water of the Pharmacopoeia. The term ‘distilled water’ indicates Purified Water prepared by distillation.

**Water-bath.** A bath of boiling water unless water at another temperature is indicated. Other methods of heating may be used provided the required temperature is approximately maintained but not exceeded.

### Provisions Applicable To Monographs and Test Methods

**Expression of Content.** Where the content of a substance is defined, the expression “per cent” is used according to circumstances with one of two meanings:

- per cent w/w (percentage, weight in weight) expressing the number of grams of substance in 100 grams of final product,

- per cent v/v (percentage, volume in volume) expressing the number of millilitres of substance in 100 millilitres of final product.

The expression “parts per million” refers to the weight in weight, unless otherwise stated.

Where the content of a substance is expressed in terms of the chemical formula for that substance an upper limit exceeding 100 per cent may be stated. Such an upper limit applies to the result of the assay calculated in terms of the equivalent content of the specified chemical formula. For example, the statement ‘contains not less than 99.0 per cent and not more than 101.0 per cent of C<sub>7</sub>H<sub>6</sub>O<sub>2</sub>’ implies that the result of the assay is not less than 99.0 per cent and not more than 101.0 per cent, calculated in terms of the equivalent content of C<sub>7</sub>H<sub>6</sub>O<sub>2</sub>.

Where the result of an assay or test is required to be calculated with reference to the dried, anhydrous, ignited substance, or the substance free from solvent, the determination of loss on drying, water content, loss on ignition, content of the specified solvent, respectively is carried out by the method prescribed in the relevant test in the monograph.

**Expression of Concentrations.** The following expressions in addition to the ones given under Expression of Content are also used:

- per cent w/v (percentage, weight in volume) expressing the number of grams of substance in 100 millilitres of product
- per cent v/w (percentage, volume in weight) expressing the number of millilitres of substance in 100 grams of product.

Usually, the strength of solutions of solids in liquids is expressed as percentage weight in volume, of liquids in liquids as percentage volume in volume, of solids in semi-solid bases (e.g. creams) and of gases in liquids as percentage weight in weight.

When the concentration of a solution is expressed as parts of dissolved substance in parts of solution, it means parts by weight (g) of a solid in parts by volume (ml) of the final solution; as parts by weight (g) of a gas in parts by weight (g) of the final solution.

When the concentration of a solution is expressed in molarity designated by the symbol M preceded by a number, it denotes the number of moles of the stated solute contained in sufficient Purified Water (unless otherwise stated) to produce 1 litre of solution.

**Abbreviated Statements.** Incomplete sentences are employed in parts of the monographs for directness and brevity (for example, Iodine Value. Not more than .....; Relative Density, .....to.....) Where the tests are abbreviated, it is to be understood that the test method referred to in brackets

provides the method to be followed and that the values specified are the applicable limits.

**Weights and Measures.** The metric system of weights and measures is employed in the Pharmacopoeia. All measures are required to be graduated at 25° and all measurements in tests and assays, unless otherwise stated, are to be made at that temperature. Graduated glass apparatus used in analytical operations shall comply with the requirements stated in Chapter 2.1.6

## Monographs

### General Monographs

General monographs on dosage forms include requirements of general application and apply to all preparations within the scope of the Introduction section of the general monograph, except where a preamble limits the application. The requirements are not necessarily comprehensive for a given specific preparation; additional requirements may sometimes be given in the individual monograph for it.

**Production.** Statements given under the heading Production relate to particular aspects of the manufacturing process and are not necessarily comprehensive. However, they are mandatory instructions to manufacturers. They may relate, for example, to source materials, to the manufacturing process and its validation and control, to any in-process testing that is to be carried out by the manufacturer on the final product either on selected batches or on each batch prior to release. All this cannot be verified on a sample of the final product by an independent analyst. It is for the licensing authority to verify that the instructions have been followed.

The absence of a section on Production does not imply that attention to features such as those given above is not required. An article described in a monograph of the Pharmacopoeia is to be manufactured in accordance with the principles of good manufacturing practice and in accordance with the requirements of the Drugs and Cosmetics Rules, 1945. The general principles applicable to the manufacture and quality assurance of drugs and preparations meant for human use apply equally to veterinary products as well.

**Manufacture of Drug Products.** The opening definitive statement in certain monographs for drug products is given in terms of the active ingredient(s) only. Any ingredient(s) other than those included in the statement, must comply with the general notice on Excipients and the product must conform to the Pharmacopoeial requirements.

Official preparations are prepared only from ingredients that comply with the requirements of the pharmacopoeial monographs for those individual ingredients for which monographs are provided.

**Excipients.** Any substance added in preparing an official preparation shall be innocuous, shall have no adverse influence in the therapeutic efficacy of the active ingredients and shall not interfere with the tests and assays of the Pharmacopoeia. Care should be taken to ensure that such substances are free from harmful organisms.

### Individual Monographs

Drug products that are the subject of an individual monograph are also required to comply with the tests given in the general monographs.

**Titles.** The main title for a drug substance is the International Non-proprietary Name (INN) approved by the World Health Organization. Subsidiary names and synonyms have also been given in some cases; where included, they have the same significance as the main title.

The main titles of drug products are the ones commonly recognised in practice. Synonyms drawn from the full non-proprietary name of the active ingredient or ingredients have also been given. Where, however, a product contains one or the other of different salts of an active molecule, the main title is based on the full name of the active ingredient. For example, Chloroquine Phosphate Tablets and Chloroquine Sulphate Tablets.

**Chemical Formulae.** When the chemical structure of an official substance is known or generally accepted, the graphic and molecular formulae are normally given at the beginning of the monograph for information. This information refers to the chemically pure substance and is not to be regarded as an indication of the purity of the official material. Elsewhere, in statement of purity and strength and in descriptions of processes of assay, it will be evident from the context that the formulae denote the chemically pure substances.

Where the absolute stereochemical configuration is specified, the International Union of Pure and Applied Chemistry (IUPAC) *R/S* and *E/Z* systems of designation have been used. If the substance is an enantiomer of unknown absolute stereochemistry, the sign of the optical rotation, as determined in the solvent and under the conditions specified in the monograph, has been attached to the systematic name. An indication of sign of rotation has also been given where this is incorporated in a trivial name that appears on an IUPAC preferred list.

**Atomic and Molecular Weights.** The atomic weight or molecular weight is shown, as and when appropriate at the top right hand corner of the monograph. The atomic and molecular weights and graphic formulae do not constitute analytical standards for the substances described.

**Definition.** The opening statement of a monograph is one that constitutes an official definition of the substance,

preparation or other article that is the subject of the monograph. In certain monographs for pharmaceutical preparations the statement is given in terms of the principal ingredient(s).

In monographs on vegetable drugs, the definition indicates whether the subject of the monograph is, for example, the whole drug or the drug in powdered form.

Certain pharmaceutical substances and other articles are defined by reference to a particular method of manufacture. A statement that a substance or article is prepared or obtained by a certain method constitutes part of the official definition and implies that other methods are not permitted. A statement that a substance *may* be prepared or obtained by a certain method, however, indicates that this is one possible method and does not imply that other methods are not permissible.

**Statement of content.** The limits of content stated are those determined by the method described under Assay.

**Description.** The statements under the heading Description are not to be interpreted in a strict sense and are not to be regarded as official requirements.

**Solubility.** Statements on solubility are given in Chapter 2.4.26 and are intended as information on the approximate solubility at a temperature between 15° and 30°, unless otherwise stated, and are not to be considered as official requirements. However, a test for solubility stated in a monograph constitutes part of the standards for the substance that is the subject of that monograph.

### Test Methods

References to general methods of testing are indicated by test method numbers in brackets immediately after the heading of the test or at the end of the text.

**Identification.** The tests given under the heading Identification are not necessarily sufficient to establish absolute proof of identity. They provide a means of verifying that the identity of the material under examination is in accordance with the label on the container.

In certain monographs alternative series of identification tests are given; compliance with either one or the other set of tests is adequate to verify the identity of the article.

When tests for infrared absorption are applied to material extracted from formulated preparations, strict concordance with the specified reference spectrum may not always be possible, but nevertheless a close resemblance between the spectrum of the extracted material and the specified reference spectrum should be achieved.

### Tests and Assays

The tests and assays are the official methods upon which the standards of the Pharmacopoeia depend. The requirements

are not framed to take into account all possible impurities. It is not to be presumed, for example, that an impurity that is not detectable by means of the prescribed tests is tolerated. Material found to contain such an impurity is not of pharmacopoeial quality if the nature or amount of the impurity found is incompatible with good pharmaceutical practice.

Pharmacopoeial methods and limits should be used merely as compliance requirements and not as requirements to guarantee total quality assurance. Tests and assays are prescribed for the minimum sample available on which the attributes of the article should be measured. Assurance of quality must be ensured by the manufacturer by the use of statistically valid sampling and testing programmes.

**Tests.** Unless otherwise stated, the assays and tests are carried out at a temperature between 20° and 30°.

Where it is directed that an analytical operation is to be carried out 'in subdued light', precautions should be taken to avoid exposure to direct sunlight or other strong light. Where a procedure is directed to be performed 'protected from light' precautions should be taken to exclude actinic light by the use of low-actinic glassware, working in a dark room or similar procedures.

For preparations other than those of fixed strength, the quantity to be taken for a test or an assay is usually expressed in terms of the active ingredient. This means that the quantity of the active ingredient expected to be present and the quantity of the preparation to be taken are calculated from the strength stated on the label.

**Other Tests.** In the monographs on dosage forms and certain preparations, under the sub-heading 'Other tests' it is stated that the article complies with the tests stated under the general monograph of the relevant dosage form or preparation. Details of such tests are provided in the general monographs.

**Limits.** The limits given are based on data obtained in normal analytical practice. They take into account normal analytical errors, of acceptable variations in manufacture and of deterioration to an extent that is acceptable. No further tolerances are to be applied to the limits for determining whether or not the article under examination complies with the requirements of the monograph.

**Quantities.** Unless otherwise stated, the quantities to be taken for assays, limit tests and other tests are of the substance under examination.

In tests with numerical limits and assays, the quantity stated to be taken for testing is approximate. The amount actually used, which may deviate by not more than 10 per cent from that stated, is accurately weighed or measured and the result of analysis is calculated from this exact quantity. In tests where the limit is not numerical but usually depends upon comparison with the behaviour of a reference in the same

conditions, the stated quantity is taken for testing. Reagents are used in the prescribed amounts.

Quantities are weighed or measured with an accuracy commensurate with the indicated degree of precision. For weighings, the precision is plus or minus 5 units after the last figure stated. For example, 0.25 g is to be interpreted as 0.245 g to 0.255 g. For the measurement of volumes, if the figure after the decimal point is a zero or ends in a zero, e.g. 10.0 ml or 0.50 ml, the volume is measured using a pipette, a volumetric flask or a burette, as appropriate; in other cases, a graduated measuring cylinder or a graduated pipette may be used. Volumes stated in microlitres are measured using a micropipette or microsyringe.

The term 'transfer' is used generally to indicate a quantitative operation.

**Apparatus.** Measuring and weighing devices and other apparatus are described in the chapter entitled 'Apparatus for Tests and Assays'. A specification for a definite size or type of container or apparatus in a test or assay is given merely as a recommendation.

Unless otherwise stated, comparative tests are carried out using identical tubes of colourless, transparent, neutral glass with a flat base, commonly known as Nessler cylinders.

**Reagents and Solutions.** The reagents required for the tests and assays of the Pharmacopoeia are defined in the various chapters showing their nature, degree of purity and the strengths of the solutions to be made from them. The requirements set out are not intended to imply that the materials are suitable for use in medicine; reagents not covered by monographs in the pharmacopoeia shall not be claimed to be of IP quality.

The term 'analytical reagent grade of commerce' implies that the chemical is of a high degree of purity wherein the limits of various impurities are known. Where it is directed to use a 'general laboratory reagent grade of commerce' it is intended that a chemically pure grade material, not necessarily required to be tested for limiting or absence of certain impurities, is to be used.

**Indicators.** Where the use of an indicator solution is mentioned in an assay or test, approximately 0.1 ml of the solution shall be added, unless otherwise directed.

**Reference Substances.** Certain monographs require the use of a chemical reference substance or a biological reference preparation or a reference spectrum. These are authentic specimens chosen and verified on the basis of their suitability for intended use as prescribed in the Pharmacopoeia and are not necessarily suitable in other circumstances.

IP Reference Substances, abbreviated to IPRS (and referred to as RS in the individual monographs) are issued by the

Indian Pharmacopoeia Commission (IPC). They are the official standards to be used in cases of arbitration. Secondary Standards (Working Standards) may be used for routine analysis, provided they are standardized at regular intervals against the Reference Substances.

Biological Reference Substances, also abbreviated to IPRS and Standard Preparations of antibiotics are issued by agencies authorised by the IPC. They are standardized against the International Standards and Reference Preparations established by the World Health Organization (WHO). The potency of these preparations is expressed in International Units.

Reference spectra are published by the IPC and they are accompanied by information concerning the conditions used for sample preparation and recording of the spectra.

**Test animals.** Unless otherwise directed, animals used in a test or an assay shall be healthy and are drawn from a uniform stock, and have not previously been treated with any material that will interfere with the test or the assay.

**Calculation of results.** In determining compliance with a numerical limit in assay or test, the result should be calculated to one decimal place more than the significant figures stated and then rounded up or down as follows: if the last figure calculated is 5 to 9, the preceding figure is increased by 1; if it is 4 or less, the preceding figure is left unchanged.

**Storage.** Statements under the side-heading Storage constitute non-mandatory advice. The articles of the Pharmacopoeia are to be stored under conditions that prevent contamination and, as far as possible, deterioration. Precautions that should be taken in relation to the effects of the atmosphere, moisture, heat and light are indicated, where appropriate, in the individual monograph.

Specific directions are given in some monographs with respect to the temperatures at which Pharmacopoeial articles should be stored, where it is considered that usage at a lower or higher temperature may produce undesirable results. The storage conditions are defined by the following terms:

- Store in a dry, well-ventilated place at a temperature not exceeding 30°
- Store in a refrigerator (2° to 8°). Do not freeze
- Store in a freezer (-2° to -18°)
- Store in a deep freezer (Below -18°)

Storage conditions not related to temperature are indicated in the following terms:

- Store protected from light
- Store protected from light and moisture

Where no specific storage directions or limitations are given in the monograph or by the manufacturer, it is to be understood

that the storage conditions include protection from moisture, freezing and excessive heat (any temperature above 40°).

**Storage Containers.** The requirements, guidance and information on containers for pharmaceutical use are given in the chapter entitled Containers (6.1)

In general, an article should be packed in a well-closed container i.e. one that protects the contents from contamination by extraneous solids, liquids or vapours and from loss of the article under normal conditions of handling and storage.

Where, additionally, loss or deterioration of the article from effervescence, deliquescence or evaporation under normal conditions of storage is likely, the container must be capable

of being tightly closed, and re-closed after use.

In certain cases, special requirements of pack have been indicated in some monographs under Storage, using expressions that have been defined in chapter 6.1.

**Labelling.** The labelling of drugs and pharmaceuticals is governed by the Drugs and Cosmetics Rules, 1945. The statements that are given in the monographs under the side-heading 'Labelling' are not comprehensive. Only those that are necessary to demonstrate compliance or otherwise with the monograph have been given and they are mandatory. For example, in the monograph on Betamethasone Sodium Tablets the labelling statement is "The label states the strength in terms of the equivalent amount of betamethasone". Any other statements are included as recommendations.



## 2. TEST METHODS

2.1. Apparatus	....
2.2. Biological Methods	....
2.3. Chemical Methods	....
2.4. Physical and Physicochemical Methods	....
2.5. Pharmaceutical Methods	....
2.6. Tests on Herbal Products	....
2.7. Tests on Vaccines	....
2.8. Tests on Blood and Blood-related Products	....

## 2.1. APPARATUS

2.1.1. Gas Detector Tubes	....
2.1.2. Nessler Cylinders	....
2.1.3. Sieves	....
2.1.4. Thermometers	....
2.1.5. Ultraviolet Ray Lamps	....
2.1.6. Volumetric Glassware	....
2.1.7. Weights And Balances	....
2.1.8. Continuous Extraction of Drugs	....

### 2.1.1. Gas Detector Tubes

Gas detector tubes are cylindrical, sealed tubes consisting of an inert transparent material and constructed to allow the passage of gas. They contain reagents adsorbed onto inert substrates that are suitable for the visualisation of the substance to be detected and, if necessary, they also contain preliminary layers and/or adsorbent filters to eliminate substances that interfere with the substance to be detected. The layer of indicator contains either a single reagent for the detection of a given impurity or several reagents for the detection of several substances (monolayer tube or multilayer tube).

The test is carried out by passing the required volume of the gas under examination through the indicator tube. The length of the coloured layer or the intensity of a colour change on a graduated scale gives an indication of the impurities present.

The calibration of the detector tubes is verified according to the manufacturer's instructions.

#### Operating conditions

Examine according to the manufacturer's instructions or proceed as follows:

The gas supply is connected to a suitable pressure regulator and needle valve. Connect the flexible tubing fitted with a Y-piece to the valve and adjust the flow of gas under examination to purge the tubing to an appropriate flow (see Fig. 2.1-1). Prepare the indicator tube and fit to the metering pump following the manufacturer's instructions. Connect the open end of the indicator tube to the short leg of the tubing and operate the pump by the appropriate number of strokes to pass a suitable volume of the gas under examination through the tube. Read the value corresponding to the length of the coloured layer or the intensity of the colour on the graduated scale. If a negative result is achieved, indicator tubes can be verified with a calibration gas containing the appropriate impurity.

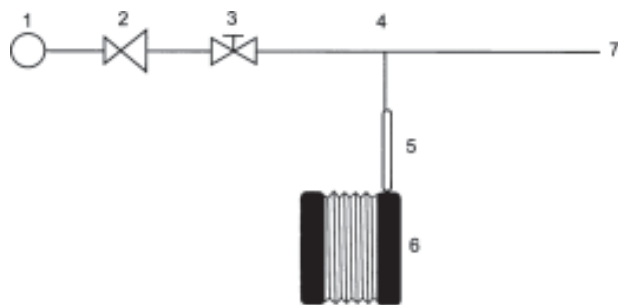

Fig. 2.1-1: Apparatus for Gas Detector Tubes

- |                       |                           |
|-----------------------|---------------------------|
| 1. gas supply         | 5. indicator tube         |
| 2. pressure regulator | 6. indicator tube pump    |
| 3. needle valve       | 7. end open to atmosphere |
| 4. "Y" piece          |                           |

In view of the wide variety of available compressor oils, it is necessary to verify the reactivity of the oil detector tubes for the oil used. Information on the reactivity for various oils is given in the leaflet supplied with the tube. If the oil used is not cited in the leaflet, the tube manufacturer must verify the reactivity and, if necessary, provide a tube specific for this oil.

**Carbon dioxide detector tube:** Sealed glass tube containing adsorbent filters and suitable supports for hydrazine and crystal violet indicators. The minimum value indicated is 100 ppm with a relative standard deviation of not more than  $\pm 15$  per cent.

**Sulphur dioxide detector tube:** Sealed glass tube containing adsorbent filters and suitable supports for the iodine and starch indicator. The minimum value indicated is 0.5 ppm with a relative standard deviation of not more than  $\pm 15$  per cent.

**Oil detector tube:** Sealed glass tube containing adsorbent filters and suitable supports for the sulphuric acid indicator. The minimum value indicated is 0.1 mg/m<sup>3</sup> with a relative standard deviation of not more than  $\pm 30$  per cent.

**Nitrogen monoxide and nitrogen dioxide detector tube:** Sealed glass tube containing adsorbent filters and suitable supports for an oxidising layer (*Cr(VI) salt*) and the diphenylbenzidine indicator. The minimum value indicated is 0.5 ppm with a relative standard deviation of not more than  $\pm 15$  per cent.

**Carbon monoxide detector tube:** Sealed glass tube containing adsorbent filters and suitable supports for di-iodine pentoxide, selenium dioxide and fuming sulphuric acid indicators. The minimum value indicated is 5 ppm or less, with a relative standard deviation of not more than  $\pm 15$  per cent.

**Hydrogen sulphide detector tube:** Sealed glass tube containing adsorbent filters and suitable supports for an appropriate lead salt indicator. The minimum value indicated is 1 ppm or less, with a relative standard deviation of not more than  $\pm 10$  per cent.

**Water vapour detector tube:** Sealed glass tube containing adsorbent filters and suitable supports for the magnesium perchlorate indicator. The minimum value indicated is 67 ppm or less, with a relative standard deviation of not more than  $\pm 20$  per cent.

### 2.1.2. Nessler Cylinders

Nessler cylinders which are used for comparative tests are matched tubes of clear, colourless glass with a uniform internal diameter and a flat, transparent base. They comply with IS 4161:1967. They are of transparent glass with a nominal capacity of 50 ml. The overall height is about 150 mm, the external height to the 50-ml mark, 110 to 124 mm, the thickness of the wall, 1.0 to 3.0 mm. The external height to the 50-ml mark of the cylinders used for a test must not vary by more than 1 mm.



### 2.1.3. Sieves

Sieves for pharmacopoeial testing are of wire cloth woven from brass, bronze, stainless steel or other suitable wire and are not coated or plated. The wires are of uniform circular cross-section. There must be no reaction between the material of the sieves and the substance being sifted. Sieves conform to the specifications given in Table 1.

Table 1

Approximate sieve number*	Approximate per cent sieving area	Nominal mesh aperture size mm	Tolerance average aperture size $\pm$ mm
4	55	4.0	0.136
8	48	2.0	0.07
10	46	1.7	0.06
12	44	1.4	0.05
16	41	1.0	0.03
		$\mu\text{m}$	$\pm \mu\text{m}$
22	37	710	25
25	36	60	21
30	38	500	18
36	36	425	15
44	38	355	13
60	37	250	13 (9.9)**
85	35	180	11 (7.6)
100	36	150	9.4 (6.6)
120	34	125	8.1 (5.8)
150	36	106	7.4 (5.2)
170	35	90	6.6 (4.6)
200	36	75	6.1 (4.1)
240	34	63	5.3 (3.7)
300	35	53	4.8 (3.4)
350	34	45	4.8 (3.1)

\*Sieve number is the number of meshes in a length of 2.54 cm in each transverse direction parallel to the wires.

\*\*Figures in parentheses refer to close tolerances; those without parentheses relate to full tolerances.

### 2.1.4. Thermometers

Unless otherwise specified, thermometers suitable for pharmacopoeial tests conform to Indian Standard 4825:1968 and are standardised in accordance with the Indian Standard 6274:1971, Method of Calibrating Liquid-in-Glass Thermometers. The thermometers are of the mercury-in-glass type and the column above the liquid is filled with nitrogen.

They may be standardised for total immersion or for partial immersion. To the extent possible, each thermometer should be employed according to the conditions of immersion under which it was standardised. In the selection of a thermometer, it is essential to consider the conditions under which it is to be used.

### 2.1.5. Ultraviolet Ray Lamps

The viewing of thin-layer chromatograms is done with the aid of a source of ultraviolet light such as a mercury vapour in a quartz lamp. A suitable filter may be fitted to eliminate the visible part of the spectrum emitted by the lamp. Where the monograph prescribes viewing under ultra-violet light of wavelength 254 nm or 365 nm, an instrument consisting of a mercury vapour lamp and a filter which gives an emission band with maximum intensity at about 254 nm or 365 nm should be used. The lamp should be capable of revealing without doubt a standard spot of sodium salicylate with a diameter of about 5mm on a chromatographic plate coated with *silica gel G*. For this purpose the following test may be carried out.

Apply to a plate coated with *silica gel G*, 5 $\mu$ l of a 0.04 per cent w/v solution of *sodium salicylate* in *ethanol (95 per cent)* for lamps of maximum output at about 254 nm and 5  $\mu$ l of a 0.2 per cent w/v solution of sodium salicylate in *ethanol (95 per cent)* for lamps of maximum output at about 365 nm. Examine the spot in a position normal to the radiation. The distance between the lamp and the plate under examination used in a pharmacopoeial test should not exceed the distance used to carry out the above test.

### 2.1.6. Volumetric Glassware

Volumetric glassware is normally calibrated at 27°. However, the temperature generally specified for measurements of volume in analytical operations of the pharmacopoeial, unless otherwise stated, is 25°. The discrepancy is inconsequential as long as the room temperature in the laboratory is reasonably constant and is around 27°.

Pharmacopoeial assays and tests involving volumetric measurements require the use of accurately calibrated glassware. Volumetric apparatus must be suitably designed to assure accuracy. The design, construction and capacity of volumetric glassware should be in accordance with those laid down by the Bureau of Indian Standards. There are two grades of apparatus available, designated Class A and Class B. Class B apparatus may be employed in routine work; Class A is intended for use in work of the highest accuracy. The tolerances on capacity for volumetric flasks, pipettes and burettes, as laid down in the relevant Indian Standards, are set out in Table 2.

Table 2

<i>Volumetric Flasks: IS 915:1975</i>								
Nominal capacity, ml	5	10	25	50	100	250	500	1000
Tolerance, $\pm$ ml								
Class A	0.02	0.02	0.03	0.04	0.06	0.1	0.15	0.2
Class B	0.04	0.04	0.06	0.08	0.15	0.2	0.3	0.8
<i>One-Mark Pipettes: IS 1117:1975</i>								
Nominal capacity, ml	1	2	5	10	20	25	50	100
Tolerance, $\pm$ ml								
Class A	0.01	0.01	0.02	0.02	0.03	0.03	0.04	0.06
Class B	0.02	0.02	0.03	0.04	0.05	0.06	0.08	0.12
<i>Graduated Pipettes: IS 4162:1967</i>								
Nominal capacity, ml		1	2	5	10	25		
Subdivision, ml			0.01	0.02	0.05	0.10	0.2	
Tolerance, $\pm$ ml								
Class A			0.006	0.01	0.03	0.05	0.1	
Class B			0.02	0.06	0.10	0.15		
<i>Burettes: IS 1997:1967</i>								
Nominal capacity, ml		10	25	50	100			
Subdivision, ml			0.05	0.05	0.1	0.1		
Tolerance, $\pm$ ml								
Class A			0.01	0.03	0.05	0.1		
Class B			0.02	0.06	0.1	0.2		

Where it is directed that a quantity be 'accurately measured', the apparatus must be chosen and used with care. A burette should be of such size that the titrant volume represents not less than 30 per cent of the nominal volume. Where less than 10ml of titrant is to be measured, a 10-ml microburette is generally required.

### 2.1.7. Weights and Balances

Pharmacopoeial assays and tests require the use of analytical balances that vary in capacity, sensitivity and reproducibility. The accuracy needed for a weighing indicates the type of balance. Where substances are to be 'accurately weighed', the weighing is to be performed so as to limit the error to not more than 0.1 per cent. For example, a quantity of 50 mg is to be weighed so that the error does not exceed 50 mg. A balance should be chosen such that the value of three times the standard deviation of the reproducibility of the balance, divided by the amount to be weighed, does not exceed 0.001

Balances should be calibrated periodically against absolute standard weights.

### 2.1.8. Continuous Extraction of Drugs

Where continuous extraction of a drug or any other substance is recommended in the monograph, the process consists of percolating it with a suitable solvent at a temperature approximately that of the boiling-point of the solvent. Any apparatus that permits the uniform percolation of the drug and the continuous flow of the vapour of the solvent around the percolator may be used. The type commonly known as the soxhlet apparatus is suitable for this purpose.

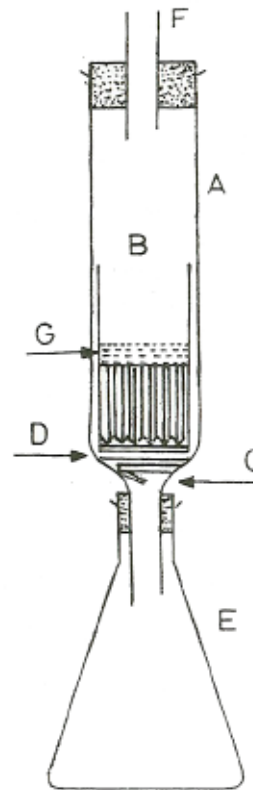

Fig. 2.1.8-1: Apparatus for continuous extraction of Drugs

A simple apparatus is shown in Fig 2.1.8-1. A is an outer tube of stout glass; the wider part is about 18 cm in length and has an internal diameter of 4.8 to 5 cm; the lower end C is about 5 cm in length and has an external diameter of about 1.6 cm. B is a straight glass tube open at both ends, about 9 cm in length and having an external diameter of about 3.8 cm; over its lower flanged end is tied firmly a piece of calico or other suitable material. D is a glass coil, which supports the margin of the tube B and prevents it from resting in contact with the outer tube A. The lower end C of the outer tube A is fitted by a cork to the distilling flask E, in which a suitable quantity of the solvent has been placed. The substance to be extracted, previously moistened with the solvent or subjected to any preliminary treatment required, is introduced into the inner tube B, which is supported so that the percolate drops into

---

the outer tube. A pad of cotton wool G is placed on the top of the drug, the inner tube is lowered into position and outer tube connected by means of a suitable cork with the tube of a reflux condenser F. The flask is heated and the extraction continued as directed.

## 2.2. BIOLOGICAL METHODS

2.2.1. Abnormal Toxicity	....
2.2.2. Efficacy of Antimicrobial Preservation	....
2.2.3. Bacterial endotoxins	....
2.2.4. Depressor Substances	....
2.2.5. Test for Colony-Forming Units (CFU)	....
2.2.6. Haemolysins	....
2.2.7. Histamine	....
2.2.8. Pyrogens	....
2.2.9. Microbial Contamination	....
2.2.10. Microbiological Assay of Antibiotics	....
2.2.11. Sterility	....
2.2.12. Thiomersal	....
2.2.13. Urinary Excretion of Dextrans	....
2.2.14. Immunochemical Methods	....
2.2.15. Host-cell and Vector-derived DNA	....
2.2.16. Limes flocculationis (Lf)	....

### 2.2.1. Abnormal Toxicity

**General test.** Inject intravenously into each of five healthy mice, weighing 17 g to 22 g, the quantity of the substance under examination in 0.5 ml of *water for injections* or of sterile *normal saline solution*, over a period of 15 to 30 seconds, unless otherwise stated.

The substance passes the test if none of the mice dies within 24 hours or within the time specified in the individual monograph. If more than one animal dies, the preparation fails the test. If one of the animals dies, repeat the test. The substance passes the test if none of the animals in the second group die within the time interval specified.

**For antisera and vaccines.** Unless otherwise prescribed in the individual monograph inject intra-peritoneally one human dose but not more than 1.0 ml into each of five healthy mice, weighing 17 g to 22 g, and one human dose but not more than 5.0 ml into each of two healthy guinea pigs weighing 250 g to 350 g. The human dose is that stated on the label or in the accompanying information leaflet of the preparation under examination.

The preparation passes the test if none of the animals dies or shows signs of ill-health in 7 days following the injection. If more than one animal dies, the preparation fails the test. If one of the animals die or show signs of ill health, repeat the test. The preparation passes the test if none of the animals in the second group dies or show signs of ill health in the time interval specified.

Carry out the test also on two healthy guinea-pigs weighing 250 g to 350 g. Inject intraperitoneally into each animal one human dose but not more than 5.0 ml. The human dose is that stated on the label or in the accompanying information leaflet of the preparation to be examined. Observe the animals for 7 days.

The preparation passes the test if none of the animals shows signs of ill-health. If more than one animal dies, the preparation fails the test. If one of the animals dies or shows signs of ill health, repeat the test. The preparation passes the test if none of the animals in the second group die or show signs of ill health in the time interval specified.

### 2.2.2. Effectiveness of Antimicrobial Preservatives

*NOTE — The test for effectiveness of antimicrobial preservatives is non-mandatory and is not intended for use for routine control purposes.*

The efficacy of antimicrobial preservation of a pharmaceutical preparation on its own or, if necessary, with the addition of a suitable preservative has to be ascertained during the development of the product. The primary purpose of adding

antimicrobial preservatives to dosage forms is to prevent adverse effects arising from contamination by micro-organisms that may be introduced inadvertently during or subsequent to the manufacturing process. However, antimicrobial agents should not be used solely to reduce the viable microbial count as a substitute for good manufacturing procedures. There may be situations where a preservative system may have to be used to minimise proliferation of micro-organisms in preparations that are not required to be sterile. It should be recognised that the presence of dead micro-organisms or the metabolic by-products may cause adverse reactions in sensitised persons.

Any antimicrobial agent may show the protective properties of a preservative. However for the protection of the consumer, the concentration of the preservative shown to be effective in the final packaged product should be considerably below the concentrations of the preservative that may be toxic to human beings.

The following tests are provided to demonstrate, in multiple dose parenteral, otic, nasal, ophthalmic, oral and topical products made with aqueous bases or vehicles, the effectiveness of any added preservatives, during the shelf lives of the preparations to ensure that the antimicrobial activity has not been impaired by storage. The tests apply only to the product in the original, unopened container in which it was supplied by the manufacturer.

The test consists of challenging the preparation in its final container with a prescribed inoculum of suitable micro-organisms, storing the inoculated product at a prescribed temperature, withdrawing samples from the container at specified intervals of time and counting the organisms in the samples removed. The preservative properties of the product are considered adequate if, in the conditions of the test, there is a significant fall or no increase in the number of micro-organisms in the inoculated preparation after storage for the times and at the temperatures prescribed.

The organisms specified for use in the tests are intended to be representative of those that might be expected to be found in the environment in which the preparation is manufactured, stored and used. However, they should be supplemented by other strains or species, especially those likely to be found in the conditions under a particular product is made or used, or that might offer a particular challenge to the type of product being tested. Single-strain challenges (rather than mixed cultures) should be used throughout.

**Precautions.** Challenge tests should be conducted under conditions that prevent accidental contamination of the product during the test but the precautions taken to prevent contamination should not affect the survival of organisms in the product being examined.

**Test organisms.** The following test organisms are used in the test.

*Candida albicans* ATCC 10231

*Aspergillus niger* ATCC 16404

*Escherichia coli* ATCC 8739

*Pseudomonas aeruginosa* ATCC 9027

*Staphylococcus aureus* ATCC 6538

**Media.** For the initial cultivation of the test organism, use Soyabean Casein Digest Agar Medium for bacterial cultures and Sabouraud-dextrose agar for *C. albicans* and *A. niger*, or any other media not less nutritive than the said media.

**Preparation of inoculum.** From a recently grown stock culture of each of the test organisms, subculture on the surface of a suitable volume of the above stated media. Incubate the bacterial cultures at 30° to 35° for 18 to 24 hours and incubate the cultures of *C. albicans* and *A. niger* at 20° to 25°C for 48 hours and 7 days respectively.

Using sterile *saline solution*, harvest the bacterial and *C. albicans* cultures and dilute suitably with the sterile *saline solution* to bring the count to about  $1 \times 10^8$  per ml. Similarly harvest *A. niger* culture with sterile *saline solution* containing 0.05 per cent w/v of *polysorbate 80* and adjust the spore count to about  $1 \times 10^8$  per ml with sterile *saline solution*.

Alternatively, the stock culture organisms may be grown in a suitable liquid medium, and the cells may be harvested by centrifugation, washed and resuspended in sterile *saline solution* to give the required microbial or spore count.

Determine the number of colony-forming units (CFU) per ml in each suspension. This value serves to determine the size of inoculum to be used in the test. If the standardised suspensions are not used within 2 hours, it should be stored in a refrigerator. Periodically monitor the stored suspensions by the plate-count method to determine any loss of viability.

**Procedure.** Inoculate each original product container or product tube (when original container is not suitable for inoculation with a sterile syringe fitted with needle, transfer 20 ml per capped bacterial tube) with one of the standard microbial suspensions using a ratio equivalent to 0.1 ml of inoculum suspension to 20 ml of product and mix. The final concentration should be between  $1 \times 10^5$  and  $1 \times 10^6$  micro-organisms per ml of the product. Determine the number of viable micro-organisms by the plate count method in each inoculum suspension and from there calculate the initial concentration of micro-organisms per ml of product being examined.

Incubate the inoculated containers or tubes at 20° to 25°. Determine the viable count (by the plate count method) at 7, 14, 21 and 28 days subsequent to inoculation. Record also any change observed in the appearance.

**Interpretation.** The preservative is effective in the product examined if (a) the concentration of viable bacteria are not

more than 0.1 per cent of the initial concentrations by the 14<sup>th</sup> day, (b) the concentrations of viable yeasts and moulds remain at or below the initial concentration during the first 14 days and, (c) the concentration of each test micro-organism remains at or below these designated levels during the remainder of the 28-day test period.

### 2.2.3. Bacterial Endotoxins

The test for bacterial endotoxins (BET) measures the concentration of bacterial endotoxins that may be present in the sample or on the article to which the test is applied using a lysate derived from the hemolymph cells or amoebocytes of the horseshoe crab, *Limulus polyphemus*. Other species of horseshoe crab namely *Tachypleus gigas*, *Tachypleus tridentatus* and *Carcinoscropsius rotundicauda* also yield amoebocyte lysate having similar activity.

The addition of a solution containing endotoxins to a solution of the lysate produces turbidity, precipitation or gelation of the mixture. However, addition of a chromogenic substrate to a solution of the lysate results in development of colour due to release of chromophore from the substrate upon activation by the endotoxin present in the solution. The rate of reaction depends on the concentration of endotoxin, the pH and the temperature. The reaction requires the presence of certain bivalent cations, a clotting cascade enzyme system and clottable protein, all of which are provided by the lysate.

The following methods can be used to monitor the endotoxin concentration in a product official in the Pharmacopoeia and to determine whether the product complies with the limit specified in the monograph.

Method A. Gel-Clot Limit Test Method

Method B. Semi-quantitative Gel-Clot Method

Method C. Kinetic Turbidimetric Method

Method D. Kinetic Chromogenic Method

Method E. End-Point Chromogenic Method

When a monograph includes a test for bacterial endotoxins without mentioning a method, the test is carried out by Method A. Any one of the other four methods may be employed as an alternative method provided it yields results of equivalent reliability with the preparation under examination.

The quantities of endotoxins are expressed in defined Endotoxin Units (EU). With the adoption of the second International Standard for endotoxin by the Expert Committee on Biological Standards of the World Health Organization, 1 EU = 1 IU.

The endotoxin limit for a given test preparation is calculated from the expression  $K/M$ , where M is the maximum dose



administered to an adult (taken as 70 kg for this purpose) per kg per hour. The value of K is 5.0 EU/kg for parenteral preparations except those administered intrathecally, and is 0.2 EU/kg for preparations intended to be administered intrathecally.

The test should be carried out in a manner that avoids microbial contamination. If necessary, the containers should be treated to eliminate surface endotoxins that may be present by heating in an oven at 250° or above for not less than 60 minutes or by using a validated oven cycle or by any other means.

Before carrying out the test for endotoxins in the preparation under examination it is necessary to verify

- (a) in the case of gel-clot methods, the sensitivity of the lysate;
- (b) in the case of quantitative methods, the linearity of the standard curve;
- (c) the absence of interfering factors, which inhibit or enhance the reaction or otherwise interfere with the test on the preparation under examination;
- (d) the adequacy of the containers to resist adsorption of endotoxins.

### Special Reagents

#### Endotoxin reference standard and control standard endotoxin.

The Endotoxin Reference Standard (ERS) is the freeze-dried, purified endotoxin of *Escherichia coli*, which is calibrated in Endotoxin Units (EU) by comparison with the International Standard.

The Endotoxin Reference Standard (ERS) or any other suitable preparation the activity of which has been determined in relation to the ERS or the International Standard using a gel-clot or other suitable method is maintained by the Central Drugs Laboratory, Kolkata.

The freeze-dried endotoxin should be reconstituted with *water BET* by mixing intermittently for 30 minutes using a vortex mixer. The concentrate should be stored in a refrigerator for not more than 28 days. Subsequent dilutions of the concentrate should be made by mixing vigorously for not less than 3 minutes before use. Each dilution should be mixed for not less than 30 seconds before proceeding to make the next dilution.

A Control Standard Endotoxin (CSE) which is suitably standardised against the ERS may be used for routine bacterial endotoxin testing.

**Lysate.** A lysate of amoebocytes from either of the species of the horseshoe crab, *Limulus polyphemus*, *Tachypleus gigas*, *Tachypleus tridentatus* or *Carcinoscorpius rotundicauda* reconstituted as stated on the label. The species from which the lysate is obtained is stated on the label.

**Water BET.** Water that gives a negative result under the conditions prescribed in the test for bacterial endotoxins on the preparation under examination. It may be prepared by distilling water thrice times in an apparatus fitted with an effective device to prevent the entrainment of droplets or by other means that give water of the desired quality.

**0.1 M Hydrochloric acid BET.** Prepare from *hydrochloric acid* using *water BET*. After adjustment of the pH to 6.0 to 8.0 with *0.1M sodium hydroxide BET* it gives a negative result under the conditions of the test.

**0.1 M Sodium hydroxide BET.** Prepare from *sodium hydroxide* using *water BET*. After adjustment of the pH to 6.0 to 8.0 with *0.1M hydrochloric acid BET* it gives a negative result under the conditions of the test.

**Tris-chloride buffer pH 7.4 BET.** Dissolve 0.6057 g of *tris (hydroxymethyl) methylamine* in 30 ml of *water BET*, add 0.33 ml of *hydrochloric acid*, dilute to 100 ml with *water BET* and mix. It gives a negative result under the conditions of the test.

**NOTE** — Special reagents used in the test may use the suffix ‘LAL’, ‘TAL’ or ‘CAL’, as the case may be, to indicate the species of the horseshoe crab from which the amoebocyte lysate is derived. They have the same significance as the suffix ‘BET’.

### Gel-Clot Methods

Methods A and B depend on the formation of a firm gel when a solution containing bacterial endotoxins is incubated after mixing with the lysate. Method A is conducted as a limit test wherein both the replicate solutions of the preparation under examination must contain endotoxin in the concentration less than the endotoxin limit concentration specified in the individual monograph. Method B determines the endotoxin concentration semiquantitatively in the preparation under examination.

**Sensitivity of the lysate.** Confirm the labelled sensitivity of each new batch of lysate prior to use in the test using at least one vial of each batch of lysate. Prepare a series of dilutions of CSE to give concentrations of 2I, I, 0.5I and 0.25I, where I is the labelled sensitivity of the lysate in EU per ml. Perform the test as given under Method on these four standard concentrations in duplicate and include a negative control consisting of *water BET*. At least the final dilution in each series must give a negative result.

Calculate the average of the logarithms of the lowest concentration of endotoxin in each series of dilutions for which a positive result is found. The geometric mean end-point concentration is the measured sensitivity of the lysate in EU/ml, which is calculated using the following expression:

Geometric mean end-point concentration = antilog ( $\Sigma e/f$ )

where,  $\sum e$  = sum of the log end-point concentrations of the series of dilutions used;

$f$  = number of replicate test-tubes.

This average gives the estimated lysate sensitivity which must lie between  $0.5\lambda$  and  $2\lambda$ .

**Test for interfering factors.** The possibility of interference with the bacterial endotoxins test by certain factors should be borne in mind. For validation of the test results it must be demonstrated that the test preparation does not inhibit or enhance the reaction or otherwise interfere with the test. The validation must be repeated if the lysate vendor or the method of manufacture or the formulation of the sample is changed. Dilution of the test preparation with *water BET* is the easiest method for overcoming inhibition.

The allowable dilution level or Maximum Valid Dilution (MVD) is dependent on the concentration of the product, the endotoxin limit for the product and the lysate sensitivity. It is calculated by the following expression:

$$\text{MVD} = \frac{\text{Endotoxin limit} \times \text{Concentration of the test solution} *}{\lambda}$$

where,  $\lambda$  is the labelled sensitivity of the lysate (EU/ml).

\* Concentration of the test solution is expressed as mg/ml in case the endotoxin limit is specified by weight (EU/mg), or as Units/ml in case the endotoxin limit is specified by Unit (EU/Unit), or as 1.0 ml/ml in case the endotoxin limit is specified by volume (EU/ml).

**Preparation of test solutions.** Prepare replicates of solutions A to D as indicated in the table.

Solution	Final concentration of added CSE in the solution	Number of replicates
A	–	4
B	2l	4
	0.5l	4
	0.25l	4
C	2l	4
	1	2
	0.5l	2
D	0.25l	2
	–	2

Solution A = Solution of the product at a dilution at or below MVD (test solution).

Solution B = Test solution spiked with indicated CSE concentrations (Positive Product Control; PPC).

Solution C = Standard solution with indicated CSE concentrations in *water BET*.

Solution D = *Water BET* (Negative Control; NC).

**Method.** Carry out the following procedure in receptacles such as tubes, vials or wells of micro-titre plates. Into each of the chosen receptacle, add an appropriate volume of negative control (NC), standard CSE solutions in *water BET*, test solution and positive product control (PPC). At intervals that will permit the reading of each result, add to each receptacle an equal volume of the appropriately constituted lysate unless single test vials are used. Mix the sample-lysate mixture gently and place in an incubating device such as a water-bath or a heating block, accurately recording the time at which the receptacles are so placed. Incubate each receptacle at  $37^{\circ} \pm 1^{\circ}$  undisturbed for  $60 \pm 2$  minutes. Remove the receptacles and examine the contents carefully. A positive reaction is characterised by the formation of a firm gel that retains its integrity when inverted through  $180^{\circ}$  in one smooth motion. Record this result as positive (+). A negative result is characterised by the absence of such a gel or by the formation of a viscous gel that does not maintain its integrity. Record such a result as negative (–). Handle the receptacles with care to avoid subjecting them to unwanted vibrations as false negative observations may result.

Calculate the geometric mean end-point concentration of solutions of series B and C by using the formula described under Sensitivity of the lysate.

**Calculation and interpretation of results.** The test for interfering factors is valid if

- solutions of series A and D give negative results;
- the results obtained with solutions of series C confirm the labelled sensitivity of the lysate;
- the geometric mean of the end-point concentration of solutions of series B is not more than 2l or not less than 0.5l.

If the result obtained is outside the specified limit, the test preparation under examination is acting as an inhibitor or activator. The interfering factors may be eliminated by further dilution (not greater than MVD), filtration, neutralisation, inactivation or by removal of the interfering substances. The use of a more sensitive lysate permits the use of greater dilution of the preparation under examination.

Ultrafiltration may be used, if necessary, when the interfering factor passes through a filter with a nominal separation limit corresponding to a molecular weight of 10,000 to 20,000, such as asymmetrical membrane filters of cellulose triacetate. Such filters should be checked for the presence of any factors causing false positive results. The material retained on the filter, which contains the endotoxins, is rinsed with *water BET* or *tris-chloride buffer pH 7.4 BET*. The endotoxins are recovered in the *water BET* or the buffer. The endotoxin concentration in the test volume and the final volume are determined for each preparation under examination.



Establish that the chosen treatment effectively eliminates interference without removing endotoxins by repeating the test for interfering factors using the preparation under examination to which the CSE has been added and which has been submitted to the chosen treatment.

#### Method A. Gel-Clot Limit Test Method

**Preparation of test solutions.** Unless otherwise prescribed, prepare the solutions and dilutions with *water BET*. If necessary, adjust the pH of the solution under examination to 6.0 to 8.0 using sterile *0.1M hydrochloric acid BET*, *0.1M sodium hydroxide BET* or a suitable buffer prepared with *water BET*.

Prepare the sample solution at any dilution at or below MVD. Use *water BET* as negative control (NC) and two positive controls. One of the positive controls consists of the CSE at a concentration of  $2\lambda$  and the other consists of the test solution spiked with CSE to give a concentration of  $2\lambda$  (PPC).

**Method.** Carry out the procedure on the test solutions in duplicate as described under Test for interfering factors.

**Interpretation of results.** The product under examination complies with the bacterial endotoxin test if the positive product control is positive and the negative control as well as the test solutions are negative. The test is not valid if the positive product control is negative or if the negative control is positive.

The product under examination meets the requirements of the test if the endotoxin content is less than the endotoxin limit stated in the individual monograph.

**Retests.** If a positive result is found for one of the test solution duplicates and a negative result for the other, the test may be repeated as described above. The results of the retest should be interpreted as for the initial test.

#### Method B. Semi-Quantitative Gel-Clot Method

**Preparation of test solutions.** Prepare test solutions at concentrations of MVD, 0.5 MVD, 0.25 MVD or any other appropriate dilutions relative to the dilution at which the test for interfering factors was completed. Additionally, prepare a similar series of test solutions spiked with  $2\lambda$  of CSE each (PPC).

**Method.** Carry out the procedure on the test solutions in duplicate as described under Test for interfering factors.

**Calculation and interpretation of results.** To calculate the endotoxin concentration in the product, determine for the series of test solutions the lowest concentration or the highest dilution giving a positive (+) reaction. Multiply this dilution factor with  $\lambda$  to obtain the endotoxin concentration of the product.

For instance, if MVD is equal to 8 and the positive reaction was obtained at 0.25 MVD and  $\lambda$  was equal to 0.125 EU/ml, the endotoxin concentration in the test solution will be  $8 \times 0.25 \times 0.125 = 0.25$  EU/ml.

If none of the dilutions of the series gives a positive reaction, the endotoxin concentration will be less than the value obtained by multiplying the lowest dilution factor with  $\lambda$ . If all the dilutions of the series give a positive reaction, the endotoxin concentration will be more than the value obtained by multiplying the highest dilution factor with  $\lambda$ .

Calculate the endotoxin content of the product under examination from the endotoxin concentration. The product under examination meets the requirements of the test if the endotoxin content is less than the endotoxin limit stated in the individual monograph.

#### Quantitative Methods

The quantitative methods include

- kinetic turbidimetric method (Method C),
- kinetic chromogenic method (Method D) and
- end-point chromogenic method (Method E).

These methods make use of a linear regression of the log response with the log endotoxin concentration.

To ascertain the precision or validity of the turbidimetric and chromogenic methods, preparatory tests are conducted to see that the criteria for the standard curve are valid and that the test solution does not interfere with (inhibit or enhance) the reaction.

The kinetic turbidimetric method is a photometric assay measuring the increase in turbidity caused by the reaction of the endotoxin with the lysate. The kinetic turbidimetric assay is a method measuring either the time (onset time) needed to reach a predetermined absorbance of the reaction mixture or the rate of turbidity development.

The kinetic chromogenic method is a photometric assay measuring the colour developed by the chromophore released from a chromogenic substrate by the reaction of the endotoxin with the lysate. The kinetic chromogenic assay is a method measuring either the time (onset time) needed to reach a predetermined absorbance of the reaction mixture or the rate of colour development.

The end-point chromogenic method is a photometric assay measuring the colour developed by the chromophore released from a chromogenic substrate by the reaction of the endotoxin with the lysate. The end-point assay is a method measuring the colour intensity at the end of an incubation period after the reaction is stopped by the addition of a suitable acid.

**Preparation of the standard curve.** Using CSE, prepare solutions of not less than three endotoxin concentrations to

obtain a linear standard curve. Carry out the procedure using at least two replicates of each standard endotoxin solution in accordance with the instructions of the lysate manufacturer (volume ratios, incubation times, temperature, pH, etc.).

The regression line must have a linearity with the coefficient of correlation,  $r$ , being not greater than  $-0.980$  for the range of endotoxin concentrations.

**Test for interfering factors.** For validation of the test results, it must be demonstrated that the test preparation does not inhibit or enhance the test or otherwise interfere with the test. The validation must be repeated if the lysate vendor or the method of manufacture or formulation of the sample is changed. The initial dilution may be prepared using the following expression:

$$\text{Initial dilution} = \frac{\text{Endotoxin limit of the test solution}}{C^*}$$

\*C is the lowest CSE concentration of the standard curve expressed in EU/ml.

**Preparation of test solutions.** Prepare solutions A to D as given below.

Solution A = Solution of the product under examination at the initial dilution (test solution).

Solution B = Test solution spiked with CSE at a concentration at or near the middle of the standard curve (PPC).

Solution C = Standard solutions of CSE in *water BET* covering the linear part of the standard curve.

Solution D = *Water BET* (NC).

The pH of the solutions must be in the range specified by the manufacturer of the lysate, usually between 6.0 and 8.0. Adjust the pH, if necessary, by addition of sterile *0.1 M hydrochloric acid BET*, *0.1 M sodium hydroxide BET* or a suitable buffer prepared with *water BET*.

**Method.** Carry out the test in duplicate receptacles such as wells of a micro-titre plate. Into each chosen receptacle, add an appropriate volume of solution D (NC), standard CSE solutions in *water BET* (solution C), test solution (solution A) and solution B (PPC). Add the lysate and carry out the assay in accordance with the instructions given by the lysate manufacturer.

**Calculation and interpretation of results.** Calculate the endotoxin concentration of solutions A and B from the regression equation obtained with solutions of series C. Calculate the mean percentage recovery of the added endotoxin by subtracting the mean endotoxin concentration in solution A from the mean endotoxin concentration in solution B.

The test for interfering factors is valid only if

- the negative control (solution D) does not yield a value higher than the limit for the value required in the description of the lysate employed;
- the CSE solutions of series C comply with the requirements given under Preparation of the standard curve;
- the mean percentage recovery of added endotoxin in solution B is between 50 per cent and 150 per cent.

If the mean percentage recovery is beyond the specified range, the interfering factors must be removed by the procedure described under the Gel-Clot Method.

#### Method C. Kinetic Turbidimetric Method

#### Method D. Kinetic Chromogenic Method

**Preparation of test solutions.** Unless otherwise prescribed, prepare the solutions to be employed in the test using *water BET*. If necessary, adjust the pH of the solution under examination to 6.0 to 8.0 using sterile *0.1 M hydrochloric acid BET*, *0.1 M sodium hydroxide BET* or a suitable buffer prepared with *water BET*.

Prepare the test solution at a suitable dilution. Use not less than three CSE concentrations to prepare a linear standard curve. Use *water BET* as negative control and one positive control. The positive control consists of the test solution spiked with CSE to give an endotoxin concentration at the middle or below the middle point of the standard curve (PPC).

**Method.** Carry out the procedure described under Test for interfering factors.

**Interpretation of results.** The assay is valid only if

- the standard curve is linear for the range of CSE concentrations used;
- the co-efficient of correlation,  $r$ , is not greater than  $-0.980$ ;
- the mean percentage recovery of the added endotoxin in the positive product control is between 50 per cent and 150 per cent.

The product under examination meets the requirements of the test if the mean endotoxin content of the replicates, after correction for dilution and concentration, is less than the endotoxin limit stated in the individual monograph.

#### Method E. End-Point Chromogenic Method

**Preparation of test solutions.** Unless otherwise prescribed, prepare the solutions to be employed in the test using *water BET*. If necessary, adjust the pH of the solution under examination to 6.0 to 8.0 using sterile *0.1 M hydrochloric acid BET*, *0.1 M sodium hydroxide BET* or a suitable buffer prepared with *water BET*.

Prepare the test solution at a suitable dilution. Prepare a reagent blank and not less than three dilutions of CSE in *water BET* to prepare a linear standard curve. Use *water BET* as negative control and one positive control. The positive control consists of the test solution spiked with CSE to give an endotoxin concentration at the middle or below the middle point of the standard curve (PPC).

**Method.** Carry out the procedure described under Test for interfering factors. The chromogenic substrate and lysate are added to the solution and incubated for the recommended time. Stop the reaction and measure the absorbance at the wavelength specified by the lysate manufacturer.

Perform the linear regression analysis of the absorbance on the endotoxin concentration using standard statistical methods (method of least squares is usually suitable). Do not average the absorbance values of the replicates of each standard before performing the linear correlation regression analysis. Determine the endotoxin concentration of the test solution from the standard curve.

**Interpretation of results.** The assay is valid only if

- the standard curve is linear for the range of CSE concentrations used;
- the co-efficient of correlation,  $r$ , is not less than 0.980;
- the mean percentage recovery of the added endotoxin in positive product control is between 50 per cent and 150 per cent.

The product under examination meets the requirements of the test if the mean endotoxin content of the replicates, after correction for dilution and concentration, is less than the endotoxin limit stated in the individual monograph.

## 2.2.4. Depressor Substances

### Special Reagents

**Heparinised saline solution.** A sterile *saline solution* containing 50 Units of heparin in 1 ml.

**Standard histamine solution.** Dissolve a suitable quantity of *histamine dihydrochloride* or *histamine acid phosphate* in sufficient *water* or *saline solution* to produce a solution containing 0.1 µg of histamine,  $C_5H_9N_3$ , per ml. Make suitable with the solvent dilutions used for preparing the solution.

### Test Animal

Use a healthy, adult cat, either male or non-pregnant female, weighing not less than 2 kg. Weigh the cat and anaesthetise it by intraperitoneal injection of an anaesthetic substance such as chloralose or a suitable barbiturate that allows maintenance of a uniform blood pressure. Immobilize the animal, protect it from loss of body heat and maintain it so that the rectal

temperature remains within physiological limits. Introduce a tube into the trachea. Expose a carotid or other suitable artery, separate it from surrounding tissues, insert a cannula filled with heparinised saline solution and connect to a device capable of recording the blood pressure continuously. Then expose a femoral vein and insert another cannula filled with heparinised saline solution to facilitate intravenous injection of solutions of histamine and of the substance under examination.

Determine the sensitivity of the animal to histamine by injecting intravenously, at regular intervals of not less than 5 minutes, doses of standard histamine solution corresponding to 0.05, 0.1 and 0.15 µg of histamine per kg of body weight of the animal. Repeat the injection of the dose of 0.1 µg per kg at least three times. Administer the second and subsequent injections not less than 1 minute after the blood pressure has returned to a constant level. Use the animal for the test only if the responses to the graded doses are clearly different and the responses to the repeated injections of the dose of 0.1 µg per kg are approximately the same and correspond to a decrease in pressure of not less than 20 mm of mercury.

### Method

Dissolve the substance under examination in sufficient *saline solution* or other diluent prescribed in the individual monograph, to give the test solution of the concentration specified in the monograph. Follow the same time schedule established during the injection of standard histamine solution. Inject intravenously per kg of the cat's weight, 1.0 ml of standard histamine solution followed by an injection of the specified amount of the test solution and finally 1.0 ml of standard histamine solution. The second and third injections are given not less than 1 minute after the blood pressure has returned to a constant level. When a common cannula is used for both the standard histamine solutions and test solutions, each injection of the standard and the test solutions should be immediately followed by an injection of approximately 2.0 ml of *saline solution* to flush any residues from the tubing. Measure the change in blood pressure following each of the three injections. The depressor response to the test solution is not greater than one-half of the mean depressor response to the two associated doses of the standard histamine solution. If this requirement is not met, continue the series of injections similarly until it consists of five doses, of which the three doses of 1.0 ml each of standard histamine solution are alternated with two doses of the test solution. Measure the change in blood pressure following each of the additional injections. The substance passes the test if the depressor response to each dose of the test solution is not greater than the mean of the respective depressor responses to the associate doses of the standard histamine solution representing 0.1 µg of histamine per kg.

If the depressor response to either dose of the test solution is greater than the mean of the depressor response to the associated doses of the standard histamine solution the test may be continued in the same animal or in another animal similarly prepared and tested for responses to the standard histamine solution. If the test continued in the same animal after the last dose of the standard histamine solution of the initial series, administer four more injections of which two are doses of the test solution and two are doses of 1.0 ml each of the standard histamine solution alternately in sequence. If the test is continued in another animal, prepare a fresh solution of the substance under examination from an independent container or containers of the substance and inject a series of five doses comprising the standard histamine solution and test solution in accordance with the initial injection sequence. Measure the change in blood pressure following each of the additional injections. Compute the difference between each response to the dose of the test solution and the mean of the associated doses of the standard histamine solution in the entire series, initial and additions, and calculate the average of all such differences is such that in the specified dose the depressor response to the test solution is not greater than the depressor response to the dose of the standard histamine solution representing 0.1 µg of histamine per kg and if not more than one-half of the depressor responses to the test solution are greater than the mean of the respective depressor responses to the associated doses of the standard histamine solution representing 0.1 µg of histamine per kg.

## 2.2.5 Test for Colony-forming Units (CFU)

The number of colony-forming units (CFU) must be determined on the contents of at least 5 containers of the freeze-dried vaccine. If the containers are vacuum sealed, check for vacuum before use.

### Special reagents

#### 1. Dilute Sauton's Medium

##### a. Sauton's fluid medium

Ferric ammonium citrate (brown)	0.05 g
L-Asparagine	4.0 g
Citric Acid	2.0 g
Magnesium Sulphate (MgSO <sub>4</sub> ·7H <sub>2</sub> O)	0.5 g
Dipotassium hydrogen phosphate (K <sub>2</sub> HPO <sub>4</sub> )	0.5 g
Glycerin	60.0 ml
Distilled water to	1000 ml

Dissolve the solid ingredients in 50 ml of *distilled water* by warming on a water-bath. Add glycerin and sufficient *distilled water* to produce 1000.0 ml, mix well and filter. Adjust the pH

of the filtrate to 7.2 ± 0.2 with 5 M *sodium hydroxide*. Sterilise by heating at 121° for 30 minutes. Store the medium in a light resistant container in a cold place.

##### b. Phosphate buffer solution

Dipotassium hydrogen phosphate	1.452 g
Sodium dihydrogen phosphate	7.601 g
Sodium Chloride	4.8 g
Distilled water to	1000 ml

Dissolve the solids in sufficient *distilled water* to produce 1000.0 ml. Warm on a water-bath, if necessary, and filter.

##### c. Polysorbate 80 solution

Polysorbate 80	10 ml
Phosphate buffer solution	90 ml

Mix and sterilise by heating at 121° for 20 minutes. Store in a cold place.

##### d. Dilute Sauton's solution

Sauton's fluid medium	1000 ml
Distilled water to	3000 ml

Mix well and adjust the pH to 7.2 ± 0.2. Distribute into suitable containers. Sterilise by heating at 121° for 20 minutes.

Add 5 ml of sterile *polysorbate solution* to 600 ml of *dilute sauton's solution* immediately before use.

#### 2. Lowenstein – Jensen Medium : LJ Medium

##### a. Mineral salt solution

Potassium hydrogen phosphate (K <sub>2</sub> HPO <sub>4</sub> )	2.4 g
Magnesium Sulphate (MgSO <sub>4</sub> )	0.24 g
Magnesium Citrate	0.6 g
L-Asparagine	3.6 g
Glycerin	12.0 ml
Distilled water	600 ml

Dissolve the solid ingredients in 50 ml of *distilled water* by warming on a water-bath. Add glycerin and 5 ml of *distilled water* and mix well. Sterilise by heating at 121° for 25 minutes.

##### b. Malachite green solution

Prepare a 2 per cent w/v solution of *malachite green* in *sterile water* with aseptic precautions, allowing the dye to dissolve by incubating for 1 to 2 hours at 37°. Shake the solution before use.

##### c. Lowenstein-Jensen solution

Mineral salt solution	600 ml
Malachite green solution	20 ml
Egg fluid	1000 ml

*NOTE* — All utensils used to prepare the medium must be sterile. The eggs must be fresh, i.e. not more than 4 days old.



About 20 to 22 eggs depending on size, will be required to provide a litre of egg fluid.

Wash the eggs thoroughly in warm water with a brush and a plain alkaline soap, rinse them in running water for 30 minutes, drain off water and allow the eggs to dry covered with paper until the following day. Alternatively, dry them at once by sprinkling them with methylated spirit and burning it off. Crack the eggs with a sterile knife, pour the contents into a sterile beaker and beat the whites and yolks together with sterile egg whisk until a uniform egg fluid mixture free from air bubbles is obtained.

To the mixed egg fluid add the *mineral salt solution* and *malachite green solution* with aseptic precautions, mix thoroughly, distribute 5-ml aliquots in to 25-ml McCartney bottles and screw on the caps tightly. Lay the bottles horizontally in the inspissator. A hot air oven fitted with a fan may be used for inspissation. Preheat the oven to 85° and place the shelves on which the bottles of medium have been laid horizontally. When the temperature reaches 80° adjust the thermostat to this level and continue heating for another 60 minutes to coagulate and solidify the medium.

### Method

Reconstitute each of 5 containers of the freeze-dried vaccine as for human use with the diluent stated on the label and pool the contents. Prepare three dilutions of the pooled vaccine so as to obtain an optimum of 100,40 and 20 colonies from an inoculum of 0.2 ml, using *dilute Sauton's medium* for preparing the dilutions. Normally dilutions in the range of 1:20,000, 1:40,000 and 1:80,000 would be required.

Inoculate 0.2 ml of each of the dilutions on to *LJ medium* by surface inoculation. Use three bottles of *LJ medium* for the first and second dilutions each and six bottles for the third dilution. Incubate the inoculated *LJ medium* at 37° for 28 days and count the number of colonies. Calculate the number of culturable particles by standard statistical methods which give full weightage to a dilution yielding, on an average, the optimum or lesser number of colonies, reduced weightage to a dilution yielding upto twice the optimum number of colonies and no weightage to a dilution yielding more than twice the optimum number of colonies.

The vaccine passes the test if 0.1 ml of the reconstituted vaccine contains between  $1 \times 10^5$  and  $33 \times 10^5$  colony forming units.

*NOTE* — The validity of the test for colony-forming units (CFU) must be determined by carrying out the test on a preparation of known potency.

### 2.2.6. Haemolysins

Add 1 volume of fresh donor serum to 1 volume of a 10 per cent v/v suspension of A<sub>1</sub> corpuscles in *saline solution* and

add 1 volume to 1 volume of a similar suspension of B corpuscles; a similar test using O corpuscles may be done as a negative control. If the serum is more than 24 hours old, add 1 volume of fresh group O serum free of lysins to each tube as a source of complement. Mix the contents of each tube, incubate at 37° for 1 hour and examine the supernatant liquid for haemolysis.

A serum giving a positive result in this test is further examined as follows. Dilute 1 volume of the serum with 3 volumes of *saline solution* and mix 1 volume of the diluted serum with 1 volume of fresh group O serum free of lysins and 1 volume of a 10 per cent v/v suspension, in *saline solution*, of A<sub>1</sub> or B corpuscles (whichever were lysed in the first test). At the same time, in two further tubes, mix 1 volume of *saline solution* with 1 volume of the fresh group O serum free of lysins. To one of these tubes add 1 volume of a 10 per cent v/v suspension, in *saline solution*, of A<sub>1</sub> corpuscles and to the other 1 volume of a similar suspension of B corpuscles. Incubate the tubes at 37° for 1 hour, mix the contents of each tube and examine the supernatant liquid for haemolysis. No haemolysis should show in any of the tubes. Group O blood samples whose sera show the presence of haemolysins should be regarded as unsafe for transfusion to recipients of other groups and must be labelled accordingly.

### 2.2.7. Histamine

#### Solutions

##### Solution 1

Sodium chloride	160.0 g
Potassium chloride	4.0 g
Calcium chloride, anhydrous	2.0 g
Magnesium chloride, anhydrous	1.0 g
Disodium hydrogen phosphate dodecahydrate	0.10 g
Water for injections to	1000 ml

##### Solution 2

Solution 1	50.0 ml
Atropine sulphate	0.5 mg
Sodium bicarbonate	1.0 g
Dextrose monohydrate	0.5 g
Water for injections to	1000 ml

Solution 2 should be freshly prepared and used within 24 hours.

#### Method

Kill a guinea-pig weighing 250 g to 350 g that has been deprived of food for the preceding 24 hours. Remove a portion of the

distal small intestine 2 cm long and empty the isolated part by rinsing carefully with solution 2 using a syringe. Attach a fine thread to each end and make a small transverse incision in the middle of the piece of intestine. Place it in an organ bath with a capacity of 10 ml to 20 ml, containing solution 2 maintained at a constant temperature of 34° to 36° and pass through the solution a current of a mixture of 95 parts of oxygen and 5 parts of carbon dioxide. Attach one of the threads near to the bottom of the organ bath. Attach the other thread to an isotonic myograph and record the contractions of the organ on a kymograph or any other suitable means of giving a permanent record. If a lever is used, its length is such that the movements of the organ are amplified about 20 times. The tension on the intestine should be about 9.8 mN (1 g) and it should be adjusted to the sensitivity of the organ. Flush out the organ bath with solution 2. Allow to stand for 10 minutes. Flush 2 or three times more with solution 2. Stimulate a series of contractions by the addition of measured volumes between 0.2 ml and 0.5 ml of a solution of *histamine dihydrochloride* having a strength that produces reproducible submaximal responses. This dose is the high dose. Flush the organ bath 3 times with solution 2 before each addition of histamine. The successive additions should be made at regular intervals allowing a complete relaxation between additions (about 2 minutes). Add equal volumes of a weaker dilution of *histamine dihydrochloride* which produces reproducible responses approximately half as great as the high dose. This dose is the low dose. Continue the regular additions of high and low doses of histamine solution as indicated above, and alternate each addition with an equal volume of a dilution of the solution under examination, adjusting the dilution so that the contraction of the intestine, if any, is smaller than that due to the high dose of histamine. Determine whether the contraction, if any, is reproducible and that the responses to the high and low doses of histamine are unchanged. Calculate the activity of the substance under examination in terms of its equivalent in micrograms of histamine base from the dilution determined as above.

The quantity so determined does not exceed the quantity prescribed in the individual monograph.

If the solution under examination does not produce a contraction, prepare a fresh solution adding a quantity of histamine corresponding to the maximum tolerated in the monograph and note whether the contractions produced by the preparation with the added histamine correspond to the amount of histamine added. If this is not the case, or if the contractions caused by the substance under examination are not reproducible or if subsequent responses to high and low doses of histamine are diminished, the results of the test are invalid and the test for depressor substances (2.2.4) must be done.

## 2.2.8. Pyrogens

The test involves measurement of the rise in body temperature of rabbits following the intravenous injection of a sterile solution of the substance under examination. It is designed for products that can be tolerated by the test rabbit in a dose not exceeding 10 ml per kg injected intravenously within a period of not more than 10 minutes.

### Test Animals

Use healthy, adult rabbits of either sex, preferably of the same variety, weighing not less than 1.5 kg, fed on a complete and balanced diet and not showing loss of body weight during the week preceding the test. House the animals individually in an area of uniform temperature ( $\pm 2^\circ$ ), preferably with uniform humidity, and free from disturbances likely to excite them.

Do not use animals for pyrogen tests more frequently than once every 48 hours. After a pyrogen test in the course of which a rabbit's temperature has risen by 0.6° or more, or after a rabbit has been given a test substance that was adjudged pyrogenic, at least 2 weeks must be allowed to elapse before the animals is used again.

### Materials

All glassware, syringes and needles must be thoroughly washed with *water for injections* and heated in a hot air oven at 250° for 30 minutes or at 200° for 1 hour. Treat all diluents and solutions for washing and rinsing of devices in a manner that will assure that they are sterile and pyrogen-free.

The retaining boxes for rabbits in which the temperature is being measured by electrical device should be made in such a way that the animals are retained only by loosely-fitting neck-stocks and the rest of the body remains relatively free so that the rabbits may sit in a normal position. The animals must be put in the boxes 1 hour before the test and remain in them throughout the test. Ensure that the room temperature where the test is carried out is within 3° of that of the rabbits living quarters or in which the rabbits have been kept for at least 18 hours before the test. Withhold food from the animals overnight and until the test is completed; withhold water during the test.

### Recording of Temperature

Use an accurate temperature-sensing device such as a clinical thermometer or thermistor or other suitable probes that have been calibrated to assure an accuracy of 0.1° and have been tested to determine that a maximum reading is reached in less than 5 minutes. Insert the thermometer or temperature-sensing probe into the rectum of the test rabbit to a depth of about 5 cm. The depth of insertion is constant for any one rabbit in any one test. If an electrical device is used, it should be inserted in the rectum of the rabbit 90 minutes before the injection of

the solution being examined and left in position throughout the test. After a period of time not less than that previously determined as sufficient, record the rabbit's body temperature.

#### **Preliminary Test (Sham Test)**

If animals are used for the first time in a pyrogen test or have not been used during the 2 previous weeks, condition them 1 to 3 days before testing the substance under examination by injecting intravenously into them 10 ml per kg of body weight of a pyrogen-free *saline solution* warmed to about 38.5°.

Record the temperatures of the animals, beginning at least 90 minutes before injection and continuing for 3 hours after injection of the solution being examined. Any animal showing a temperature variation of 0.6° or more must not be used in the main test.

#### **Main Test**

Carry out the test using a group of three rabbits.

*Preparation of the sample.* Dissolve the substance under examination in, or dilute with, pyrogen-free *saline solution* or other solution prescribed in the monograph. Warm the liquid under examination to approximately 38.5° before injection.

*Procedure.* Record the temperature of each animal at intervals of not more than 30 minutes, beginning at least 90 minutes before the injection of the solution under examination and continuing for 3 hours after the injection. Not more than 40 minutes immediately preceding the injection of the test dose, record the "initial temperature" of each rabbit, which is the mean of two temperatures recorded for that rabbit at an interval of 30 minutes in the 40-minute period. Rabbits showing a temperature variation greater than 0.2° between two successive readings in the determination of "initial temperature" should not be used for the test. In any one group of test animals, use only those animals whose "initial temperatures" do not vary by more than 1° from each other, and do not use any rabbit having a temperature higher than 39.8° and lower than 38°.

Inject the solution under examination slowly into the marginal vein of the ear of each rabbit over a period not exceeding 4 minutes, unless otherwise prescribed in the monograph. The amount of sample to be injected varies according to the preparation under examination and is prescribed in the individual monograph. The volume of injection is not less than 0.5 ml per kg and not more than 10 ml per kg of body weight. Record the temperature of each animal at half-hourly intervals for 3 hours after the injection. The difference between the "initial temperature" and the "maximum temperature" which is the highest temperature recorded for a rabbit is taken to be its response. When this difference is negative, the results is counted as a zero response.

*Interpretation of results.* If the sum of the responses of the group of three rabbits does not exceed 1.4° and if the response

of any individual rabbit is less than 0.6°, the preparation under examination passes the test. If the response of any rabbit is 0.6° or more, or if the sum of the response of the three rabbits exceeds 1.4°, continue the test using five other rabbits. If not more than three of the eight rabbits show individual responses of 0.6° or more, and if the sum of responses of the group of eight rabbits does not exceed 3.7°, the preparation under examination passes the test.

### **2.2.9. Microbial Contamination**

The following tests are designed for the estimation of the number of viable aerobic micro-organisms present and for detecting the presence of designated microbial species in pharmaceutical substances. The term 'growth' is used to designate the presence and presumed proliferation of viable micro-organisms.

#### **Preliminary Testing**

The methods given herein are invalid unless it is demonstrated that the test specimens to which they are applied do not, of themselves, inhibit the multiplication under the test conditions of micro-organisms that can be present. Therefore, prior to doing the tests, inoculate diluted specimens of the substance under examination with separate viable cultures of *Escherichia coli*, *Salmonella* species, *Pseudomonas aeruginosa* and *Staphylococcus aureus*. This is done by adding 1 ml of not less than 10<sup>-3</sup> dilutions of a 24-hr broth culture of the micro-organisms to the first dilution (in *buffer solution pH 7.2*, medium A or medium 1) (see below) of the test material and following the test procedure. If the organisms fail to grow in the relevant medium, the procedure should be modified by (a) increasing the volume of diluent with the quantity of test material remaining the same, or (b) incorporating a sufficient quantity of a suitable inactivating agent in the diluents, or (c) combining the aforementioned modifications so as to permit growth of the organisms in the media. If inhibitory substances are present in the sample, medium B may be used.

Alternatively, the neutralisers mentioned in Table 1 may be added.

Where inhibitory substances are contained in the product and the latter is soluble, the Membrane filtration method described under Total Aerobic Count may be used.

If in spite of incorporation of suitable inactivating agents and a substantial increase in the volume of diluent, it is still not possible to recover the viable cultures described above and where the article is not suitable for applying the membrane filtration method it can be assumed that the failure to isolate the inoculated organism may be due to the bactericidal activity of the product. This may indicate that the article is not likely

Table 1

Type of microbial agent	Inactivator	Concentration	Comment
Phenolics	Sodium lauryl sulphate	4 g per litre	Add after sterilisation of buffered sodium chloride peptone solution pH 7.0
	Polysorbate 80 and lecithin Egg yolk	30 g/l and 3g/l 5 ml/l - 50 ml/l	
Organo-mercurials	Sodium thioglycollate	0.5 g/l – 5 g/l	
Halogens	Sodium thiosulphate	5 g/l	
Quarternary ammonium Compounds	Egg yolk/lecithin	5 ml/l - 50 ml/l	Add after sterilisation of buffered sodium chloride peptone solution pH 7.0

to be contaminated with the given species of micro-organisms. However, monitoring should be continued to establish the spectrum of inhibition and bactericidal activity of the article.

#### Solution and Media

The following media have been found to be suitable for the tests for microbial examination. Other media may be used if they have similar nutritive and selective properties for the micro-organisms to be tested for.

Culture media may be prepared as given below or dehydrated culture media may be used provided that, when reconstituted as directed by the manufacturer, they have similar ingredients and/or yield media comparable to those obtained from the formulae given below.

Where agar is specified in a formula, use agar that has a moisture content of not more than 15 per cent. Where water is called for in a formula, use *purified water*. Unless otherwise indicated, the media should be sterilised by heating in an autoclave at 121° for 15 minutes.

In preparing media by the formulas given below, dissolve the soluble solids in the water, using heat if necessary, to effect complete solution and add solutions of hydrochloric acid or sodium hydroxide in quantities sufficient to yield the required pH in the medium when it is ready for use. Determine the pH at 25° ± 2°

#### Buffered sodium chloride-peptone solution pH 7.0

Potassium dihydrogen phosphate	3.6 g
Disodium hydrogen phosphate	7.2 g
Sodium chloride	4.3 g
Peptone (meat or casein)	1.0 g
Water to	1000 ml

0.1 per cent to 1.0 per cent w/v *polysorbate 20* or *polysorbate 80* may be added. Sterilise.

#### Media for Preliminary testing

##### Medium A. Fluid Lactose Medium

Beef extract	3.0 g
Pancreatic digest of gelatin	5.0 g
Lactose	5.0 g
Water to	1000 ml

Cool as quickly as possible after sterilisation. Adjust the pH after sterilisation to 6.9 ± 0.2. Sterilise and cool immediately.

##### Medium B. Fluid Casein Digest-Soya Lecithin-Polysorbate 20 Medium

Pancreatic digest of casein	20 g
Soya lecithin	5 g
Polysorbate 20	40 ml
Water to	1000 ml

Dissolve the pancreatic digest of casein and Soya lecithin in water, heating in a water-bath at 48° to 50° for about 30 minutes to effect solution. Add *polysorbate 20*, mix and dispense as desired. Sterilise.

#### Specific media

##### Medium 1. Casein soya bean digest broth

Pancreatic digest of casein	17.0 g
Papain digest of soya bean	3.0 g
Sodium chloride	5.0 g
Dipotassium hydrogen phosphate	2.5 g
Dextrose monohydrate	2.5 g
Water to	1000 ml

Adjust the pH so that after sterilisation it is 7.3 ± 0.2. Sterilise.



**Medium 2. Casein soya bean digest agar**

Pancreatic digest of casein	15.0 g
Papaic digest of soyabean meal	5.0 g
Sodium chloride	5.0 g
Agar	15.0 g
Water to	1000 ml

Adjust the pH so that after sterilisation it is  $7.3 \pm 0.2$ . Sterilise.

**Medium 3. Sabouraud-dextrose agar with antibiotics**

Peptones (meat and casein)	10.0 g
Dextrose monohydrate	40.0 g
Agar	15.0 g
Water to	1000 ml

Adjust the pH so that after sterilisation it is  $5.6 \pm 0.2$ . Sterilise. Immediately before use, add 0.1 g of benzylpenicillin sodium and 0.1 g of tetracycline or alternatively add 50 mg of chloramphenicol per litre of medium as sterile solutions.

**Medium 4. Lactose broth**

Beef extract	3.0 g
Pancreatic digest of gelatin	5.0 g
Lactose monohydrate	5.0 g
Water to	1000 ml

Adjust the pH so that after sterilisation it is  $6.9 \pm 0.2$ . Sterilise and cool immediately.

**Medium 5. Enrichment broth (Enterobacteria enrichment broth-Mossel)**

Pancreatic digest of gelatin	10.0 g
Dextrose monohydrate	5.0 g
Dehydrated ox bile	20.0 g
Potassium dihydrogen phosphate	2.0 g
Disodium hydrogen phosphate dihydrate	8.0 g
Brilliant green	15 mg
Water to	1000 ml

Adjust the pH so that after heating it is  $7.2 \pm 0.2$ . Heat at  $100^\circ$  for 30 minutes and cool immediately.

**Medium 6. Crystal violet, neutral red, bile agar with dextrose**

Yeast extract	3.0 g
Pancreatic digest of gelatin	7.0 g
Bile salts	1.5 g
Lactose monohydrate	10.0 g
Sodium chloride	5.0 g
Dextrose monohydrate	10.0 g
Agar	15.0 g
Neutral red	30 mg
Crystal violet	2 mg
Water to	1000 ml

Adjust the pH so that after sterilisation it is  $7.3 \pm 0.2$ . Sterilise.

**Medium 7. MacConkey broth**

Pancreatic digest of gelatin	20.0 g
Lactose	10.0 g
Dehydrated ox bile	5.0 g
Bromocresol purple	10 mg
Water to	1000 ml

Adjust the pH so that after sterilisation it is  $7.3 \pm 0.2$ . Sterilise.

**Medium 8. MacConkey agar**

Pancreatic digest of gelatin	17.0 g
Peptones (meat and casein, equal parts)	3.0 g
Lactose	10.0 g
Sodium Chloride	5.0 g
Bile salts	1.5 g
Agar	13.5 g
Neutral red	30.0 mg
Crystal violet	1.0 mg
Water to	1000 ml

Adjust the pH so that after sterilisation it is  $7.1 \pm 0.2$ . Boil the mixture of solids and water for 1 minute to effect solution. Sterilise.

**Medium 9. Nutrient Broth**

Beef extract	10 g
Peptone	10 g
Sodium Chloride	5 mg
Water to	1000 ml

Dissolve with the aid of heat. Adjust the pH to 8.0 to 8.4 with *5 M sodium hydroxide* and boil for 10 minutes. Filter, sterilise by maintaining at  $115^\circ$  for 30 minutes and adjust the pH to  $7.3 \pm 0.1$ .

**Medium 10. Levin Eosin-Methylene Blue Agar**

Pancreatic digest of gelatin	10.0 g
Dibasic potassium phosphate	2.0 g
Agar	15.0 g
Lactose	10.0 g
Eosin Y	400.0 mg
Methylene Blue	65.0 mg
Water to	1000 ml

Dissolve the pancreatic digest of gelatin, dibasic potassium phosphate and agar in water with warming and allow to cool. Just prior to use, liquefy the gelled agar solution and the remaining ingredients, as solutions, in the following amounts and mix. For each 100 ml of the liquefied agar solution use 5 ml

of a 20 per cent w/v solution of lactose, and 2 ml of a 2 per cent w/v solution of eosin Y, and 2 ml of a 0.33 per cent w/v solution of methylene blue. The finished medium may not be clear. Adjust the pH after sterilisation to  $7.1 \pm 0.2$ . Sterilise.

**Medium 11. Selenite F broth**

Peptone	5 g
Lactose	4 g
Disodium hydrogen phosphate	10 g
Sodium hydrogen selenite	4 g
Water to	1000 ml

Dissolve, distribute into sterile containers and sterilise by maintaining at  $100^\circ$  for 30 minutes.

**Medium 12. Tetrathionate bile brilliant green broth**

Peptone	8.6 g
Dehydrated ox bile	8.0 g
Sodium Chloride	6.4 g
Calcium carbonate	20.0 g
Potassium tetrathionate	20.0 g
Brilliant green	70 mg
Water to	1000 ml

Heat just to boiling; do not reheat. If necessary, adjust the pH so that after sterilisation it is  $7.3 \pm 0.2$ . Sterilise, allow to cool to  $45-50^\circ$ ; add, where necessary, gentamicin sulphate corresponding to 20 mg of gentamicin base and pour into Petri dishes.

**Medium 13. Bismuth Sulphite Agar Medium***Solution (I)*

Beef extract	6 g
Peptone	10 g
Agar	24 g
Ferric Citrate	0.4 g
Brilliant green	10 mg
Water to	1000 ml

Dissolve with the aid of heat and sterilise by maintaining at  $115^\circ$  for 30 minutes.

*Solution (II)*

Ammonium Bismuth Citrate	3 g
Sodium Sulphate	10 g
Anhydrous disodium hydrogen phosphate	5 g
Dextrose monohydrate	5 g
Water to	100 ml

Mix, heat to boiling, cool to room temperature, add 1 volume of solution (2) to 10 volumes of solution (1) previously melted and cooled to a temperature of  $55^\circ$  and pour.

Bismuth Sulphite Agar Medium should be stored at  $2^\circ$  to  $8^\circ$  for 5 days before use.

**Medium 14. Desoxycholate citrate agar**

Beef extract	10.0 g
Peptone	10.0 g
Lactose monohydrate	10.0 g
Trisodium Citrate	20.0 g
Ferric Citrate	1.0 g
Sodium desoxycholate	5.0 g
Neutral red	0.02 g
Agar	13.5 g
Water to	1000 ml

Adjust the pH so that after heating it is  $7.3 \pm 0.2$ . Mix and allow to stand for 15 minutes. With continuous stirring, bring gently to the boil and maintain at boiling point until solution is complete. Cool to  $50^\circ$ , mix, pour into Petri dishes and cool rapidly.

Care should be taken not to overheat Desoxycholate Citrate Agar during preparation. It should not be remelted and the surface of the plates should be dried before use.

**Medium 15. Xylose-Lysine-Desoxycholate agar**

Xylose	3.5 g
L- Lysine	5.0 g
Lactose	7.5 g
Sucrose	7.5 g
Sodium chloride	5.0 g
Yeast extract	3.0 g
Phenol red	80 mg
Agar	13.5 g
Sodium desoxycholate	2.5 g
Sodium thiosulphate	6.8 g
Ferric ammonium citrate	800 mg
Water to	1000 ml

Adjust the pH so that after sterilisation it is  $7.4 \pm 0.2$ . Heat just to boiling, cool to  $50^\circ$  and pour into Petri dishes. Do not heat in an autoclave.

**Medium 16. Brilliant green agar**

Peptone	10.0 g
Yeast extract	3.0 g
Lactose	10.0 g
Sucrose	10.0 g
Sodium Chloride	5.0 g
Phenol Red	80.0 g
Brilliant green	12.5 mg
Agar	12.0 g
Water to	1000 ml

Mix, allow to stand for 15 minutes and heat to boiling for 1 minute. Adjust the pH so that after sterilisation it is  $6.9 \pm 0.2$ . Immediately before use, sterilise, cool to  $50^\circ$  and mix before pouring into Petri dishes.

**Medium 17. Triple Sugar, Iron agar**

Beef extract	3.0 g
Yeast extract	3.0 g
Peptone	20.0 g
Lactose	10.0 g
Sucrose	10.0 g
Dextrose monohydrate	1.0 g
Ferrous sulphate	0.2 g
Sodium Chloride	5.0 g
Phenol Red	24 mg
Agar	12.0 g
Water to	1000 ml

Mix, allow to stand for 15 minutes. Adjust the pH so that after heating it is  $7.0 \pm 0.2$ . Bring to boil and maintain at boiling point until solution is complete. Do not re-heat.

**Medium 18. Urea broth**

Potassium dihydrogen orthophosphate	9.1 g
Anhydrous disodium hydrogen phosphate	9.5 g
Urea	20.0 g
Yeast extract	0.1 g
Phenol red	10 mg
Water to	1000 ml

Mix, sterilise by filtration and distribute aseptically in sterile containers.

**Medium 19. Cetrinide agar**

Pancreatic digest of gelatin	20.0 g
Magnesium chloride	1.4 g
Potassium sulphate	10.0 g
Cetrinide	0.3 g
Agar	13.6 g
Glycerin	10.0 g
Water to	1000 ml

Heat to boiling 1 minute with shaking. Adjust the pH so that after sterilisation it is 7.0 to 7.4. Sterilise.

**Medium 20. Pseudomonas Agar Medium for detection of Fluorescein**

Pancreatic digest of casein	10.0 g
Peptic digest of animal tissue	10.0 g
Anhydrous dibasic potassium phosphate	1.5 g
Magnesium sulphate ( $MgSO_4 \cdot 7H_2O$ )	1.5 g
Glycerin	10.0 ml
Agar	15.0 g
Water to	1000 ml

Dissolve the solid components in water before adding glycerin. Heat with frequent agitation and boil for 1 minute to effect solution. Sterilise. Adjust the pH after sterilisation to  $7.2 \pm 0.2$ .

**Medium 21. Pseudomonas Agar Medium for Detection of Pyocyanin**

Pancreatic digest of gelatin	20.0 g
Anhydrous Magnesium chloride	1.4 g
Anhydrous potassium sulphate	10.0 g
Agar	15.0 g
Glycerin	10.0 ml
Water to	1000 ml

Dissolve the solid components in *water* before adding glycerin. Heat with frequent agitation and boil for 1 minute to effect solution. Sterilise. Adjust the pH after sterilisation to  $7.2 \pm 0.2$ .

**Medium 22. Vogel-Johnson Agar Medium**

Pancreatic digest of casein	10.0 g
Yeast extract	5.0 g
Mannitol	10.0 g
Dibasic potassium phosphate	5.0 g
Lithium chloride	5.0 g
Glycine	10.0 g
Agar	16.0 g
Phenol red	25.0 mg
Water to	1000 ml

Boil the solution of solids for 1 minute. Sterilise, cool to between  $45^\circ$  to  $50^\circ$  and add 20 ml of a 1 per cent w/v sterile solution of potassium tellurite. Adjust the pH after sterilisation to  $7.2 \pm 0.2$ .

**Medium 23. Mannitol Salt Agar Medium**

Pancreatic digest of casein	5.0 g
Peptic digest of animal tissue	5.0 g
Beef extract	1.0 g
D-Mannitol	10.0 g
Sodium Chloride	75.0 g
Agar	15.0 g
Phenol Red	25 mg
Water to	1000 ml

Mix, heat with frequent agitation and boil for 1 minute to effect solution. Sterilise. Adjust the pH after sterilisation to  $7.4 \pm 0.2$ .

**Medium 24. Baird – Parker agar**

Pancreatic digest of casein	10.0 g
Beef extract	5.0 g
Yeast extract	1.0 g
Lithium Chloride	5.0 g
Agar	20.0 g
Glycine	12.0 g
Sodium pyruvate	10.0 g
Water to	1000 ml

Adjust the pH so that after heating it is  $7.4 \pm 0.2$ . Heat just to boiling, cool to  $50^\circ$  and pour into Petri dishes. Do not heat in an autoclave.

#### Medium 25. Reinforced medium for clostridia

Beef extract	10.0 g
Peptone	10.0 g
Yeast extract	3.0 g
Soluble starch	1.0 g
Dextrose monohydrate	5.0 g
Cysteine hydrochloride	0.5 g
Sodium chloride	5.0 g
Sodium acetate	3.0 g
Agar	0.5 g
Water to	1000 ml

Hydrate the agar, dissolve by heating to boiling with continuous stirring. If necessary, adjust the pH so that after sterilisation it is about 6.8. Sterilise.

#### Medium 26. Columbia agar

Pancreatic digest of casein	10.0 g
Meat peptic digest	5.0 g
Heart pancreatic digest	3.0 g
Yeast extract	5.0 g
Maize starch	1.0 g
Sodium chloride	5.0 g
Agar, according to gelling power	10.0 g to 15.0 g

Hydrate the agar, dissolve by heating to boiling with continuous stirring. If necessary, adjust the pH so that after sterilisation it is  $7.3 \pm 0.2$ . Sterilise, allow to cool to  $45-50^\circ$ ; add, where necessary, gentamicin sulphate corresponding to 20 mg of gentamicin base and pour into Petri dishes.

#### Suitability of dehydrated media and validity of the tests

The following tests must be performed at least on each lot of dehydrated media.

Grow the following test strains separately, in tubes containing medium A at  $30-35^\circ$  for 18-24 hours.

*Staphylococcus aureus* ATCC 6538, *Pseudomonas aeruginosa* ATCC 9027, *Escherichia coli* ATCC 8739, and *Salmonella typhimurium* (no specific strain).

Dilute portions of each of the cultures using *buffered sodium chloride-peptone solution pH 7.0* to make test suspensions containing about 1000 viable micro-organisms per ml. Mix equal volumes of each suspension and use 0.4 ml (approximately 100 micro-organisms of each strain) as an inoculum in tests for the afore-mentioned organisms in the presence and

absence of the product under examination. A positive result for the respective micro-organisms must be obtained.

**Sampling.** Sampling of the product must follow a well-defined sampling plan that takes into account the batch size, the characteristics of the product, the health hazards associated with highly contaminated products and the expected level of contamination. Unless otherwise stated, use 10 ml or 10 g specimens for each of the tests specified in the individual monograph.

**Precautions.** The microbial limit tests should be carried out under conditions designed to avoid accidental contamination during the test. The precautions taken to avoid contamination must be such that, they do not adversely affect any micro-organisms that should be revealed in the test. The neutralisation of any antimicrobial activity in the sample should be done as indicated earlier.

#### Methods

##### 1. Total viable aerobic count.

The tests described hereafter allow quantitative enumeration of mesophilic bacteria and fungi that may grow under aerobic conditions. Carry out the tests under conditions designed to avoid accidental contamination of the preparation under examination. The precautions taken for avoiding contamination must be such that they do not affect any micro-organisms which are revealed in the test.

##### Pretreatment of the sample

**Water soluble products.** Dissolve 10 g or dilute 10 ml of the preparation under examination, unless otherwise specified, in *buffered sodium chloride-peptone solution pH 7.0* or any other suitable medium shown to have no antimicrobial activity under the conditions of the test and adjust the volume to 100 ml with the same medium. If necessary, adjust the pH to about 7.

**Products insoluble in water (non-fatty).** Suspend 10 g or 10 ml of the preparation under examination, unless otherwise specified, in *buffered sodium chloride-peptone solution pH 7.0* or any other suitable medium shown to have no antimicrobial activity under the conditions of the test and adjust the volume to 100 ml with the same medium. If necessary, divide the preparation under examination and homogenise the suspension mechanically.

A suitable surface-active agent such as 0.1 per cent w/v solution of *polysorbate 80* may be added to assist the suspension of poorly wettable substances. If necessary, adjust the pH of the suspension to about 7.

**Fatty products.** Homogenise 10 g or 10 ml of the preparation under examination, unless otherwise specified, with 5 g of *polysorbate 20* or *polysorbate 80*. If necessary heat to not more than  $40^\circ$ . Mix carefully while maintaining the temperature

in water-bath or in an oven. Add 85 ml of *buffered sodium chloride-peptone solution pH 7.0* or any other suitable medium shown to have no antimicrobial activity under the conditions of the test, heated to not more than 40° if necessary. Maintain this temperature for the shortest time necessary for formation of an emulsion and in any case for not more than 30 minutes. If necessary adjust the pH to about 7.

### Examination of the sample

Determine the total aerobic microbial count by any of the following methods.

**Membrane filtration.** Use membrane filters 50 mm in diameter and having a nominal pore size of not greater than 0.45 µm the effectiveness of which in retaining bacteria has been established for the type of preparation under examination. The type of filter is chosen in such a way that the bacteria-retaining efficiency is not affected by the components of the sample to be examined. Cellulose nitrate filters may be used for aqueous, oily and weakly alcoholic solutions and cellulose acetate filters for strongly alcoholic solutions. Sterilise and assemble the filtration apparatus described under the test for sterility (2.2.11).

Transfer 10 ml or a quantity of each dilution containing 1 g of the preparation under examination to each of two membrane filters and filter immediately. If necessary, dilute the pretreated preparation so that a colony count of 10 to 100 may be expected. Wash each membrane by filtering through it three or more successive quantities, each of about 100 ml, of a suitable liquid such as *buffered sodium chloride-peptone solution pH 7.0*. For fatty substances add to the liquid *polysorbate 20* or *polysorbate 80*. Transfer one of the membrane filters, intended for the enumeration of bacteria, to the surface of a plate of medium 2 and the other, intended for the enumeration of fungi, to the surface of a plate of medium 3.

Incubate the plates for 5 days, unless a more reliable count is obtained in shorter time, at 30° to 35° in the test for bacteria and 20° to 25° in the test for fungi. Count the number of colonies that are informed. Calculate the number of micro-organisms per g or per ml of the preparation under examination, if necessary counting bacteria and fungi separately.

### Plate count methods

#### a. Pour-plate method

*For bacteria* — Using Petri dishes 9 to 10 cm in diameter, add to each dish a mixture of 1 ml of the pretreated preparation and about 15 ml of a liquefied casein soyabean digest agar such as medium 2, at not more than 45°. Alternatively, spread the pretreated preparation on the surface of the solidified medium in a Petri dish of the same diameter. If necessary dilute the pretreated preparation as described above so that a colony count of not more than 300 may be expected. Prepare at least

two such Petri dishes using the same dilution and incubate 30° to 35° for 4 days, unless a more reliable count is obtained in a shorter time. Count the number colonies that are formed. Calculate the results using plates with the greatest number of colonies but taking 300 colonies per plate as the maximum consistent with good evaluation.

*For fungi* — Proceed as described in the test for bacteria but use Sabouraud dextrose agar with antibiotics such as medium 3 in place of medium 2 and incubate the plates at 20° to 25° for 5 days, unless a more reliable count is obtained in a shorter time. Calculate the results using plates with not more than 100 colonies.

**b. Surface-spread method.** Using Petri dishes 9 to 10 cm in diameter, add 15 ml to 20 ml of medium 2 (for cultivation of bacteria) or medium 3 (for cultivation of fungi), at about 45° to each Petri dish and allow to solidify. Dry the plates, in an LAF bench or in an incubator. Spread a measured volume of not less than 0.1 ml of the sample prepared as described earlier, over the surface of the medium. Use at least two Petri dishes for each medium and each level of dilution. For incubation and calculation of the number of colony-forming units proceed as described for the pour-plate method.

**Most-probable-number method.** This method (originally known as multiple-tube or serial dilution method) is to be followed when no other method is available. The precision and accuracy of the method is less than that of the membrane filtration method or the plate-count methods.

Prepare a series of at least three subsequent tenfold dilutions of the product. From each level of dilution three aliquots of 1 g or 1 ml are used to inoculate three tubes with 9.0 ml of sterile medium 1. If necessary, *polysorbate 80* or an inactivator of antimicrobial agents (Table 1) may be added to the medium. Thus, if three levels of dilution are prepared nine tubes are inoculated. Incubate all the tubes for five days at 30-35°. Record for each level of dilution the number of tubes showing microbial growth. If detection of growth is difficult or uncertain owing to the nature of the product under examination, subculture in the same broth, or on a suitable agar medium such as medium 2 for 18 to 24 hours at the same temperature. Determine the most probable number of bacteria per g or ml of the product from Table 2.

#### Effectiveness of media and validity of the counting method.

Grow the following bacterial test strains separately, in containers containing broth medium A at 30-35° for 18-24 hours: *Staphylococcus aureus* ATCC 6538, *Escherichia coli* ATCC 8739, and *Bacillus subtilis* ATCC 6633. Grow on agar medium C without antibiotics the fungal test strain *Candida albicans* ATCC10231 at 20-25° for 48 hours, and separately, of *Aspergillus niger* ATCC 16404 at 20-25° for 7 days.

Use *buffered sodium chloride-peptone solution pH 7.0* to make reference suspensions containing about 100 colony-



Table 2  
Most-probable-number (MPN) values of bacteria

Number of positive tubes			MPN per gram	3 tubes at each level of dilution		95 per cent confidence limits	
0.1 g	0.01 g	0.001 g		Category*			
				1	2		
0	0	0	<3			-	-
0	1	0	3		x	<1	17
1	0	0	3	x		1	21
1	0	1	7		x	2	27
1	1	0	7	x		2	28
1	2	0	11		x	4	35
2	0	0	9	x		2	38
2	0	1	14		x	5	48
2	1	0	15	x		5	50
2	1	1	20		x	8	61
2	2	0	21	x		8	63
3	0	0	23	x		7	129
3	0	1	38			10	180
3	1	0	43			20	210
3	1	1	75			20	280
3	2	0	93			30	390
3	2	1	150	x		50	510
3	2	2	210		x	80	640
3	3	0	240	x		100	1400
3	3	1	460	x		200	2400
3	3	2	1100	x		300	4800
3	3	3	> 1000			-	-

\*Category 1: normal results, obtained in 95 per cent of cases.

Category 2: less likely results, obtained in only 4 per cent of cases. Results that are even less likely than those in category 2 are unacceptable.

forming units (CFUs) per ml. Use the suspension of each of the micro-organisms separately as a control of the counting methods, in the presence and absence of the product under examination.

In the membrane filtration method or the plate-count method, a count of any of the test organisms differing by not more than a factor of five from the calculated value from the inoculum is to be obtained. In the most-probable-number method the calculated value from the inoculum is to be within the 95 per cent confidence limits of the results obtained.

To test the sterility of the medium and of the diluent and the aseptic performance of the test, carry out the method using sterile *sodium chloride-peptone solution pH 7.0* as the test preparation. There must be no growth of micro-organisms.

**Interpretation of results.** The bacterial count is considered to be equal to the average number of CFUs found on medium 2. The fungal count is considered to be equal to the average

number of CFUs on medium 3. The total viable aerobic count is the sum of the bacterial count and the fungal count as described above. If there is any evidence that the same types of micro-organisms grow on both media a correction may be applied. If the count is made by the most-probable-number method the calculated value is the bacterial count.

When a limit is prescribed in a monograph it is interpreted as follows:

10<sup>2</sup> micro-organisms: maximum acceptable limit: 5 x 10<sup>2</sup>,

10<sup>3</sup> micro-organisms: maximum acceptable limit: 5 x 10<sup>3</sup>, and so on.

## 2. Tests for specified micro-organisms

**Pretreatment of samples** – Proceed as described under the test for total viable aerobic count but using lactose broth such as medium 4 or any other suitable medium shown to have no antimicrobial activity under the conditions of test in place of buffered sodium chloride-peptone solution pH 7.0.

***Enterobacteria and other gram-negative bacteria***

**Detection.** Incubate the homogenised sample at 35-37° for a time sufficient to revive the bacteria but not sufficient to encourage multiplication of the organisms (2 to 5 hours). Shake the container, transfer the quantity of the contents (homogenate A) corresponding to 1 g or 1 ml of the product to 100 ml of medium 5 and incubate at 35-37° for 18-48 hours. Subculture on plates of medium 6 and incubate at 35-37° for 18-24 hours. The product passes the test if there is no growth of colonies of gram-negative bacteria on any plate.

**Quantitative evaluation.** Inoculate suitable quantities of medium 5 with homogenate A and/or dilutions of it containing respectively 0.1 g, 0.01 g and 0.001 g (or 0.1 ml, 0.01 ml and 0.001 ml) of the product under examination. Incubate at 35-37° for 24-48 hours. Subculture each of the cultures on a plate of medium 6 to obtain selective isolation. Incubate at 35-37° for 18-24 hours. Growth of well-developed reddish colonies of gram-negative bacteria is a positive result. Note the smallest quantity of the product that gives a positive result and the largest quantity that gives a negative result. Determine from Table 3 the probable number of bacteria.

Table 3

Results for each quantity of product			Probable number of bacteria per g of product
0.1 g or 0.1 ml	0.01 g or 0.01 ml	0.001 g or 0.001 ml	
+	+	+	More than 10 <sup>3</sup>
+	+	-	Less than 10 <sup>3</sup> and more than 10 <sup>2</sup>
+	-	-	Less than 10 <sup>2</sup> and more than 10
-	-	-	Less than 10

***Escherichia coli.*** Place the prescribed quantity in a sterile screw-capped container, add 50 ml of medium 1, shake, allow to stand for 1 hour (4 hours for gelatin) and homogenise. Loosen the cap and incubate at 36-38° for 18 to 24 hours. Shake the container, transfer 1 ml to 100 ml of medium 7 and incubate at 43-45° for 18-24 hours. Subculture on plates of medium 8 at 35-37° for 18-72 hours. Growth of red, non-mucoid colonies of gram-negative rods indicates the possible presence of *Escherichia coli*.

If none of the colonies exhibits both a characteristic metallic sheen under reflected light and a blue-black appearance under transmitted light, the sample meets the requirements of the test for the absence of *Escherichia coli*. The presence of *Escherichia coli* may be confirmed by further suitable cultural and biochemical tests.

Alternatively, add 1.0 ml of the enrichment culture to a tube containing 5 ml of medium 7. Incubate in a water-bath at 36° to 38° for 48 hours. If the contents of the tube show acid and gas

carry out the following test for indole. Add 0.5 ml of Kovac's reagent, shake well and allow to stand for 1 minute; if a red colour is produced in the reagent layer indole is present.

Carry out a control test by repeating the tests adding 1.0 ml of the enrichment culture and a volume of broth containing 10 to 50 *Escherichia coli* (NTC9002) organisms, prepared from a 24-hour culture in nutrient broth such as medium 9, to 5 ml of medium 7. The test is not valid unless the results indicate that the control contains *Escherichia coli*.

**Alternative test —** By means of an inoculating loop, streak a portion from the enrichment culture (obtained in the previous test) on the surface of medium 8. Cover and invert the dishes and incubate at 43.5 to 44.5° for 24 hours. Upon examination, if none of the colonies are brick-red in colour and have a surrounding zone of precipitated bile, the sample meets the requirements of the test for the absence of *Escherichia coli*.

If the colonies described above are found, transfer the suspect colonies individually to the surface of medium 10, plated on Petri dishes. Cover and invert the plates and incubate. Upon examination, if none of the colonies exhibits both a characteristic metallic sheen under reflected light and a blue-black appearance under transmitted light, the sample meets the requirements of the test for the absence of *Escherichia coli*. The presence of *Escherichia coli* may be confirmed by further suitable cultural and biochemical tests.

***Salmonella.*** Transfer a quantity of the pretreated preparation under examination containing 1 g or 1 ml of the product to 100 ml of medium 9 in a sterile screw-capped jar, shake, allow to stand for 4 hours and shake again. Loosen the cap and incubate at 35° to 37° for 24 hours.

**Primary test —** Add 1.0 ml of the enrichment culture to each of the two tubes containing (a) 10 ml of medium 11 and (b) medium 12 and incubate at 36° to 38° for 48 hours. From each of these two cultures subculture on at least two of the following four agar media: medium 13, medium 14, medium 15 and medium 16. Incubate the plates at 36° to 38° for 18 to 24 hours. Upon examination, if none of the colonies conforms to the description given in Table 4, the sample meets the requirements of the test for the absence for the genus *Salmonella*.

If any colonies conforming to the description in Table 4 are produced, carry out the secondary test.

**Secondary test —** Subculture any colonies showing the characteristics given in Table 4 in medium 17 by first inoculating the surface of the slope and then making a stab culture with the same inoculating needle, and at the same time inoculate a tube of medium 18. Incubate at 36° to 38° for 18 to 24 hours. The formation of acid and gas in the stab culture (with or without concomitant blackening) and the absence of acidity from the surface growth in the triple sugar iron agar, together with the absence of a red colour in medium 18, indicates the

presence of salmonellae. If acid but no gas is produced in the stab culture, the identity of the organism should be confirmed by agglutination test.

Carry out the control test by repeating the primary and secondary test using 1.0 ml of the enrichment culture and a volume of broth containing 10 to 50 *salmonella abony* (NCTC 6017) organisms, prepared from a 24-hour culture in medium 9, for the inoculation of the tubes (a) and (b). The test is not valid unless the results indicate that the control contains *Salmonella*.

Table 4 – Tests for *Salmonellae*

Medium	Description of colony
Medium 13	Black or green
Medium 14	Colourless and opaque, with or without black centres
Medium 15	Red with or without black centres
Medium 16	Small, transparent and colourless, or opaque, pinkish or white (frequently surrounded by a pink or red zone)

*Pseudomonas aeruginosa*. Pretreat the preparation under examination as described above and inoculate 100 ml of medium 1 with a quantity of the solution, suspension or emulsions, thus obtained containing 1 g or 1 ml of the preparation under examination. Mix and incubate at 35° to 37° for 24 hours. Examine the medium form growth is present, streak a portion of the medium on the surface of medium 19, each plated on Petri dishes. Cover and incubate at 35° to 37° for 18 to 24 hours.

If upon examination, none of the plates contains colonies having the characteristics listed in Table 5 for the media used, the sample meets the requirement for freedom from *Pseudomonas aeruginosa*. If any colonies conforming to the description in Table 5 are produced, carry out the oxidase and pigment tests given below.

Table 5 – Tests for *Pseudomonas aeruginosa*

Medium	Characteristic colonial morphology	Fluorescence in UV light	Oxidase test	Gram stain
Medium 19	Generally greenish	Greenish	Positive	Negative rods
Medium 20	Generally colourless to yellowish	Yellowish	Positive	Negative rods
Medium 21	Generally greenish	Blue	Positive	Negative rods

Table 6 – Tests for *Staphylococcus aureus*

Selective medium	Characteristic colonial morphology	Gram stain
Medium 22	Black surrounded by yellow zones	Positive cocci (in clusters)
Medium 23	Yellow colonies with yellow zones	Positive cocci (in clusters)
Medium 24	Black, shiny, surrounded by clear zones of 2 to 5 mm	Positive cocci (in clusters)

Streak representative suspect colonies from agar surface of medium 19 on the surfaces of medium 20 for detection of fluorescein and medium 21 for detection of pyocyanin contained in Petri dishes. Cover and invert the inoculated media and incubate at 33° to 37° for not less than 3 days. Examine the streaked surfaces under ultra-violet light. Examine the plates to determine whether colonies conforming to the description in Table 5 are present.

If growth of suspect colonies occurs, place 2 or 3 drops of a freshly prepared 1 per cent w/v solution of *N, N, N', N'*-tetramethyl-4-phenylenediamine dihydrochloride on filter paper and smear with colony; if there is no development of a pink colour, changing to purple, the sample meets the requirements of the test for the absence of *Pseudomonas aeruginosa*.

*Staphylococcus aureus*. Proceed as described under *Pseudomonas aeruginosa*. If, upon examination of the incubated plates, none of them contains colonies having the characteristics listed in Table 6 for the media used, the sample meets the requirements for the absence of *Staphylococcus aureus*.

If growth occurs, carry out the coagulase test. Transfer representative suspect colonies from the agar surface of any of the media listed in Table 6 to individual tubes, each containing 0.5 ml of mammalian, preferably rabbit or horse, plasma with or without additives. Incubate in water-bath at 37° examining the tubes at 3 hours and subsequently at suitable intervals up to 24 hours. If no coagulation in any degree is observed, the sample meets the requirements of the test for the absence of *Staphylococcus aureus*.

*Clostridia*. Pretreat the preparation under examination as described above. Take two equal portions corresponding to 1 g or 1 ml of the product and heat one portion to 80° for 10 minutes and cool rapidly. Do not heat the other portion. Transfer 10 ml of each of the homogenised portions to two



containers containing 100 ml of medium 25. Incubate under anaerobic conditions at 35-37° for 48 hours. After incubation, make subcultures from each tube on medium 26 to which gentamicin has been added and incubate under anaerobic conditions at 35-37° for 48 hours. If no growth of micro-organisms is seen, the product passes the test.

Where growth occurs, subculture each distinct colony form on culture medium 26 without gentamicin, and incubate in both aerobic and anaerobic conditions. If growth of gram-positive bacilli (with or without endospores) giving a negative catalase reaction (formation of gas bubbles) occurs, it indicates the presence of *Clostridium spp.* If necessary, compare colony morphology on the two plates and apply the catalase test to eliminate the likely presence of aerobic and facultative anaerobic *Bacillus spp.* which also gives a positive catalase reaction.

### 2.2.10. Microbiological Assay of Antibiotics

The microbiological assay of an antibiotic is based upon a comparison of the inhibition of growth of micro-organisms by measured concentrations of the antibiotics under examination with that produced by known concentrations of a standard preparation of the antibiotic having a known activity. Two general methods are usually employed, the cylinder-plate (or cup-plate) method and the turbidimetric (or tube assay) method.

The cylinder-plate method (Method A) depends upon diffusion of the antibiotic from a vertical cylinder through a

solidified agar layer in a Petri dish or plate to an extent such that growth of the added micro-organism is prevented entirely in a zone around the cylinder containing a solution of the antibiotic. The turbidimetric method (Method B) depends upon the inhibition of growth of a microbial culture in a uniform solution of the antibiotic in a fluid medium that is favourable to its rapid growth in the absence of the antibiotic

The assay is designed in such a way that the mathematical model on which the potency equation is based can be proved to be valid. If a parallel-line model is chosen, the two log dose-response lines of the preparation under examination and the standard preparation should be parallel; they should be rectilinear over the range of doses used in the calculation. These conditions should be verified by validity tests for a given probability. Other mathematical models, such as the slope ratio method, may be used provided that proof of validity is demonstrated.

**Media.** Prepare the media required for the preparation of test organism inocula from the ingredients listed in Table 1. Minor modifications of the individual ingredients may be made, or reconstituted dehydrated media may be used provided the resulting media have equal or better growth-promoting properties and give a similar standard curve response.

Dissolve the ingredients in sufficient *water* to produce 1000 ml and add sufficient *1 M sodium hydroxide* or *1 M hydrochloric acid*, as required so that after sterilization the pH is as given in Table 1.

Table 1– Media: Quantities in g of ingredients per 1000 ml

Ingredient	Medium									
	A	B	C	D	E	F	G	H	I	J
Peptone	6.0	6.0	5.0	6.0	6.0	6.0	9.4	–	10.0	–
Pancreatic digest of casien	4.0	–	–	4.0	–	–	–	17.0	–	15.0
Yeast extract	3.0	3.0	1.5	3.0	3.0	3.0	4.7	–	–	–
Beef extract	1.5	1.5	1.5	1.5	1.5	1.5	2.4	–	10.0	–
Dextrose	1.0	–	1.0	1.0	–	–	10.0	2.5	–	–
Papaic digest of soyabean	–	–	–	–	–	–	–	3.0	–	5.0
Agar	15.0	15.0	–	15.0	15.0	15.0	23.5	12.0	17.0	15.0
Glycerin	–	–	–	–	–	–	–	–	10.0	–
Polysorbate 80	–	–	–	–	–	–	–	10.0*	–	–
Sodium chloride	–	–	3.5	–	–	–	10.0	5.0	3.0	5.0
Dipotassium Hydrogen Phosphate	–	–	3.68	–	–	–	–	2.5	–	–
Potassium dihydrogen phosphate	–	–	1.32	–	–	–	–	–	–	–
Final pH (after sterilisation)	6.5- 6.6	6.5- 6.6	6.95- 7.05	7.8- 8.0	7.8- 8.0	5.8- 6.0	6.0- 6.2	7.1- 7.3	6.9- 7.1	7.2- 7.4

\* Quantity in ml, to be added after boiling the media to dissolve the agar.

### Standard Preparation and Units of Activity

A Standard Preparation is an authentic sample of the appropriate antibiotic for which the potency has been precisely determined by reference to the appropriate international standard. The Potency of the standard preparation may be expressed in International Units or in  $\mu\text{g}$  per mg of the pure antibiotic.

The Standard Preparations for India are certified by the laboratory of the Indian Pharmacopoeia Commission or by any other notified laboratory(ies) and are maintained and distributed by the agency(ies) notified for the purpose.

A Standard Preparation may be replaced by a working standard prepared by any laboratory which should be compared at definite intervals under varying conditions with the standard.

**Buffer Solutions.** Prepare by dissolving the following quantities given in Table 2 of *dipotassium hydrogen phosphate* and *potassium dihydrogen phosphate* in sufficient water to produce 1000 ml after sterilisation, adjusting the pH with 8 M phosphoric acid or 10 M potassium hydroxide.

Table 2 – Buffer Solutions

Buffer No.	Dipotassium Hydrogen Phosphate, $\text{K}_2\text{HPO}_4$ (g)	Potassium Dihydrogen Phosphate, $\text{KH}_2\text{PO}_4$ (g)	pH adjusted after sterilisation to
1	2.0	8.0	6.0 $\pm$ 0.1
2	16.73	0.523	8.0 $\pm$ 0.1
3	–	13.61	4.5 $\pm$ 0.1
4	20.0	80.00	6.0 $\pm$ 0.1
5	35.0	–	10.5 $\pm$ 0.1*
6	13.6	4.0	7.0 $\pm$ 0.2

\* After addition of 2 ml of 10M potassium hydroxide

**Preparation of the Standard Solution.** To prepare a stock solution, dissolve a quantity of the Standard Preparation of a given antibiotic, accurately weighed and previously dried where so indicated in Table 3, in the solvent specified in the table, and then dilute to the required concentration as indicated. Store in a refrigerator and use within the period indicated. On the day of assay, prepare from the stock solution five or more test dilutions, the successive solutions increasing stepwise in concentration, usually in the ratio 1:1.25 for Method A or smaller for Method B. Use the final diluent specified and a sequence such that the middle or median has the concentration specified in Table 3.

**Preparation of the Sample Solution:** From the information available for the substance under examination (the “unknown”), assign to it an assumed potency per unit weight or volume, and on this assumption prepare on the day of the

assay a stock solution and test dilution as specified for each antibiotic in Table 3 but with the same final diluent as used for the Standard Preparation. The assay with 5 levels of the Standard requires only one level of the unknown at a concentration assumed equal to the median level of the standard.

**Test Organisms.** The test organism for each antibiotic is listed in Table 4, together with its identification number in the American Type Culture Collection (ATCC). Maintain a culture on slants of the medium and under the incubation conditions specified in Table 5, and transfer weekly to fresh slants

Table 4 - Test Organisms for Microbiological Assay of Antibiotics

Antibiotic	Test Organism	ATCC <sup>1</sup> No.
Amikacin	<i>Staphylococcus aureus</i>	29737
Amphotericin B	<i>Saccharomyces cerevisiae</i>	9763
Bacitracin	<i>Micrococcus luteus</i>	10240
Bleomycin	<i>Mycobacterium smegmatis</i>	607
Carbenicillin	<i>Pseudomonas aeruginosa</i>	25619
Chlortetracycline	<i>Bacillus pumilus</i>	14884
Erythromycin	<i>Micrococcus luteus</i>	9341
Framycetin	<i>Bacillus pumilus</i>	14884
	<i>Bacillus subtilis</i>	6633
Gentamicin	<i>Staphylococcus epidermidis</i>	12228
Kanamycin sulphate	<i>Bacillus pumilus</i>	14884
	<i>Staphylococcus aureus</i>	29737
Neomycin	<i>Staphylococcus epidermidis</i>	12228
Novobiocin	<i>Staphylococcus epidermidis</i>	12228
Nystatin	<i>Saccharomyces cerevisiae</i>	2601
Oxytetracycline	<i>Bacillus cereus var. mycoides</i>	11778
	<i>Staphylococcus aureus</i>	29737
Polymyxin B	<i>Bordetella bronchiseptica</i>	4617
Spiramycin	<i>Bacillus pumilus</i>	6633
Streptomycin	<i>Bacillus subtilis</i>	6633
	<i>Klebsiella pneumoniae</i>	10031
Tetracycline	<i>Bacillus cereus</i>	11778
	<i>Staphylococcus aureus</i>	29737
Tobramycin	<i>Staphylococcus aureus</i>	29737
Tylosin	<i>Staphylococcus aureus</i>	9144

1. American Type Culture Collection, 21301 Park Lawn Drive, Rockville, MD20852, USA

**Preparation of inoculum.** Prepare the microbial suspensions for the inoculum for the assay as given in Table 5. If the suspensions are prepared by these methods, growth characteristics are sufficiently uniform so that the inoculum can be adequately determined by the trials given below.

Table 3 - Stock solutions and test dilutions of Standard Preparation

Antibiotic	Standard Stock Solution					Test Dilution		
	Assay Method	Prior Drying	Initial solvent (further diluent, if different)	Final Stock Concentration per ml	Use before (number of days)	Final diluent	Median dose µg or units per ml	Incubation temp (°C)
Amikacin	B	No	Water	1 mg	14	water	10 µg	32 - 35
Amphotericin B	A	Yes	DMF <sup>7</sup>	1 mg	Same day	B5	1.0 µg	29 - 31
Bacitracin	A	Yes	0.01M HCl	100 units	Same day	B1	1.0 unit	32 - 35
Bleomycin	A	Yes	B6 <sup>8</sup>	2 units	14	B6	0.04 units	32 - 35
Carbenicillin	A	No	B1	1 mg	14	B6	20 µg	36 - 37.5
Chlortetracycline	A <sup>1</sup>	No	0.1M HCl	1 mg	4	water	2.5 µg	37 - 39
	B <sup>10</sup>	No	0.1M HCl	1 mg	4	water	0.24 µg	35 - 37
Erythromycin	A	Yes	Methanol (10 mg/ml) <sup>8</sup> (B2)	1 mg	14	B2	1.0 µg	35 - 37
Framycetin	A	Yes	B2	1 mg	14	B2	1.0 µg	30 - 35
Gentamicin	A	Yes	B2	1 mg	30	B2	0.1 µg	36 - 37.5
Kanamycin sulphate	A <sup>1</sup>	No	B2	800 units	30	B2	0.8 units	37 - 39
	B <sup>2</sup>	No	Water	1000 units	30	Water	10 units	32 - 35
Neomycin	A	Yes	B2	1 mg	14	B2	1.0 µg	36 - 37.5
Novobiocin	A	Yes	Ethanol	1 mg	5	B4	0.5 µg	32 - 35
			(10 mg/ml) <sup>9</sup> , (B2)					
Nystatin	A	Yes	DMF <sup>7</sup>	1000 units	Same day	B4	20 units	29-31
Oxytetracycline	A <sup>3</sup>	No	0.1M HCl	1 mg	4	B3	2.5 µg	32 - 35
	B <sup>2</sup>	No	0.1M HCl	1 mg	4	Water	0.24 µg	35 - 37
Polymyxin B	A	Yes	Water, (B4)	10,000 Units	14	B4	10 Units	35 - 39
Spiramycin	A <sup>4</sup>	No	Methanol	1 mg	1	B2	12-50 Units	30 - 32
Streptomycin	A <sup>4</sup>	Yes	Water	1 mg	30	Water	1.0 µg	32 - 35
	B <sup>5</sup>	Yes	Water	1 mg	30	Water	30 µg	35 - 37
Tetracycline	A <sup>3</sup>	No	0.1M HCl	1 mg	1	Water	2.5 µg	32 - 35
	B <sup>6</sup>	No	0.1M HCl	1 mg	4	Water	0.24 µg	35 - 37
Tobramycin	B	Yes	Water	1 mg	14	Water	2.5 µg	32 - 35
Tylosin	B <sup>10</sup>	No	*	1 mg	Same day	*	0.05 - 0.25 Units	37

1. With *Bacillus pumilus* ATCC 14884 as test organism; 2. With *Staphylococcus aureus* ATCC 29737 as test organism; 3. With *Bacillus cereus var mycoides* ATCC 11778 as test organism; 4. With *Bacillus subtilis* ATCC 6633 as test organism; 5. With *Klebsiella pneumoniae* ATCC 10031 as test organism; 6. With *Staphylococcus aureus* ATCC 29737 as test organism; 7. DMF = Dimethylformamide 8. In columns 4 & 7, B denotes buffer solution and the number following refers to the buffer number in Table 2; 9. Initial concentration of stock solution, 10. With *Staphylococcus aureus* ATCC 9144 as test organism.

NOTES — For Amphotericin B and Nystatin, prepare the standard solutions and the sample test solution simultaneously.

For Amphotericin B, further dilute the stock solution with dimethylformamide to give concentrations of 12.8, 16, 20, 25, & 31.2 µg per ml prior to making the test solutions. The test dilution of the sample prepared from the solution of the substance under examination should contain the same amount of dimethylformamide as the test dilutions of the Standard Preparation.

For Bacitracin, each of the standard test dilutions should contain the same amount of hydrochloric acid as the test dilution of the sample.

For Nystatin, further dilute the stock solution with dimethylformamide to give concentrations of 64.0, 80., 100.0, 125.0, 156.0 µg per ml prior to making the test dilutions. Prepare the standard response line solutions simultaneously with dilution of the sample being examined. The test dilution of the sample prepared from the solution of the substance being examined should contain the same amount of dimethylformamide as test dilutions of the Standard Preparation. Protect the solutions from light.

When making the stock solution of Polymyxin B, add 2 ml of water for each 5 mg of the weighted Standard Preparation material.

Where indicated, dry about 100 mg of the Standard Preparation before use in an oven at a pressure not exceeding 0.7 kPa at 60° for 3 hours, except in the case of Bleomycin (dry at 25° for 4 hours), Novobiocin (dry at 100° for 4 hours), Gentamicin (dry at 110° for 3 hours) and Nystatin (dry at 40° for 2 hours),

Where two level factorial assays are performed use the following test doses per ml: Amphotericin B, 1.0 to 4.0 µg; Bacitracin, 1.0 to 4.0 units; Kanamycin Sulphate, 5.0 to 20.0 units; Streptomycin, 5.0 to 20.0 µg

Table 5 – Preparation of inoculum

Test org	Incubation conditions			Suggested dilution factor	Suggested inoculum composition		
	Medium/ Method of Preparation	Temp. (°C)	Time		Medium	Amount (ml per 100 ml)	Antibiotics assayed
<i>Bacillus cereus var. mycoides</i>	A <sup>1</sup> /2	32-35	5 days	-	F	As required	Oxytetracycline Tetracycline
<i>Bacillus pumilus</i>	A <sup>1</sup> /2	32-3	5 days	-	D	As required	Chlortetracycline Framycetin Kanamycin sulphate
<i>Bacillus subtilis</i>	A <sup>1</sup> /2	32-35	5 days	-	E	As required	Framycetin
					E	As required	Kanamycin B
					B	As required	Spiramycin
					A	As required	Streptomycin
<i>Bordetella bronchiseptica</i>	A/1	32-35	24 hr	1:20	H	0.1	Polymyxin B
<i>Klebsiella pneumoniae</i>	A/1	36-37	24 hr	1:25	C	0.1	Streptomycin
<i>Micrococcus luteus</i> (9341)	A/1	32-35	24 hR	1:40	D	1.5	Erythromycin
<i>Micrococcus luteus</i> (10240)	A/1	32-35	24 hr	1:35	A	0.3	Bacitracin
<i>Mycobacterium smegmatis</i>	J/4	36-37.5	48 hr	As determined	I	1.0	Bleomycin
<i>Pseudomonas aeruginosa</i> <sup>2</sup>	A/1	36-37.5	24 hr	1:25	H	0.5	Carbenicillin
<i>Saccharomyces cerevisiae</i> (9763)	G/3	29-31	48 hr	As determined	G	1.0	Amphotericin B
<i>Saccharomyces cerevisiae</i> (2601)	G/3	29-31	48 hr	As determined	G	1.0	Nystatin
<i>Staphylococcus aureus</i> (29737)	A/1	32-35	24 hr	1:20	C	0.1	Amikacin
							Doxycycline
							Oxytetracycline
							Tetracycline
							Tobramycin
							Tylosin
							Kanamycin sulphate
<i>Staphylococcus epidermidis</i>	A/1	32-35	24 hr	1:40	D	0.03	Gentamicin
					D	0.4	Neomycin
					A	4.0	Novobiocin

1. Use Medium A containing 300 mg of manganese sulphate per litre.

2. For *Pseudomonas aeruginosa*<sup>m</sup> the assay of Carbenicillin, use the dilution yielding 25 per cent light transmission, rather than the stock suspension, for preparing the inoculum suspension.

#### Methods of preparation of test organism suspension:

- Maintain the test organism on slants of Medium A and transfer to a fresh slant once a week. Incubate the slants at the temperature indicated above for 24 hours. Using 3 ml of *saline solution*, wash the organism from the agar slant onto a large agar surface of Medium A such as a Roux bottle containing 250 ml of agar. Incubate for 24 hours at the appropriate temperature. Wash the growth from the nutrient surface using 50 ml of *saline solution*. Store the test organism under refrigeration. Determine the dilution factor which will give 25 per cent light transmission at about 530 nm. Determine the amount of suspensions to be added to each 100 ml of agar of nutrient broth by use of test plates or test broth. Store the suspension under refrigeration.
- Proceed as described in Method 1 but incubate the Roux bottle for 5 days. Centrifuge and decant the supernatant liquid. Resuspend the sediment with 50 to 70 ml of *saline solution* and heat the suspension for 30 minutes at 70°. Wash the spore suspension three times with 50 to 70 ml of *saline solution*. Resuspend in 50 to 70 ml of *saline solution* and heat-shock again for 30 minutes. Use test plates to determine the amount of the suspension required for 100 ml of agar. Store the suspension under refrigeration.
- Maintain the test organism on 10 ml agar slants of Medium G. Incubate at 32° to 35° for 24 hours. Inoculate 100 ml of nutrient broth. Incubate for 16 to 18 hours at 37° and proceed as described in Method 1.
- Proceed as described in Method 1 but wash the growth from the nutrient surface using 50 ml of Medium 1 (prepared without agar) in place of *saline solution*.

### Determination of inoculum

**For Method A.** After the suspension is prepared as given under Table 5, add different volumes of it to each of several different flasks containing 100 ml of the medium specified in Table 3 (the volume of suspension suggested in Table 3 may be used as a guide). Using these inocula, prepare inoculated plates as described for the specific antibiotic assay. While conducting cylinder-plate assays, double-layer plates may be prepared by pouring a seed layer (inoculated with the desired micro organism) over a solidified uninoculated base layer. For each Petri dish, 21 ml of base layer and 4 ml of the seed layer may be generally suitable. Fill each cylinder with the median concentration of the antibiotic (Table 3) and then incubate the plates. After incubation, examine and measure the zones of inhibition. The volume of suspension that produces the optimum zones of inhibition with respect to both clarity and diameter determines the inoculum to be used for the assay.

**For Method B.** Proceed as described for Method A and, using the several inocula, carry out the procedure as described for the specific antibiotic assay running only the high and low concentrations of the standard response curve. After incubation, read the absorbances of the appropriate tubes. Determine which inoculum produces the best response between the low and high antibiotic concentrations and use this inoculum for the assay.

### Apparatus

All equipment is to be thoroughly cleaned before and after each use. Glassware for holding and transferring test organisms is sterilised by dry heat or by steam.

**Temperature Control.** Thermostatic control is required at several stages of a microbial assay, when culturing a micro-organism and preparing its inoculum and during incubation in a plate assay. Closer control of the temperature is imperative during incubation in a tube assay which may be achieved by either circulated air or water, the greater heat capacity of water lending it some advantage over circulating air.

**Spectrophotometer.** Measuring transmittance within a fairly narrow frequency band requires a suitable spectrophotometer in which the wavelength of the light source can be varied or restricted by the use of a 580-nm filter for preparing inocula of the required density or with a 530-nm filter for reading a absorbance in a tube assay. For the latter purpose, the instrument may be arranged to accept the tube in which incubation takes place, to accept a modified cell fitted with a drain that facilitates rapid change of contents, or preferably fixed with a flow-through cell for a continuous flow-through analysis. Set the instrument at zero absorbance with clear, uninoculated broth prepared as specified for the particular antibiotic, including the same amount of test solution and formaldehyde as found in each sample.

**Cylinder-plate assay receptacles.** Use rectangular glass trays or glass or plastic Petri dishes (approximately 20 x 100 mm) having covers of suitable material and assay cylinders made of glass, porcelain, aluminium or stainless steel with outside diameter  $8 \text{ mm} \pm 0.1 \text{ mm}$ , inside diameter  $6 \text{ mm} \pm 0.1 \text{ mm}$  and length  $10 \text{ mm} \pm 0.1 \text{ mm}$ . Instead of cylinders, holes 5 to 8 mm in diameter may be bored in the medium with a sterile borer, or paper discs of suitable quality paper may be used. Carefully clean the cylinder to remove all residues. An occasional acid-bath, e.g. with about 2 *M nitric acid* or with *chromic acid solution* is needed.

**Turbidimetric assay receptacles.** For assay tubes, use glass or plastic test-tubes, e.g. 16 mm x 125 mm or 18 mm x 150 mm that are relatively uniform in length, diameter, and thickness and substantially free from surface blemishes and scratches. Cleanse thoroughly to remove all antibiotic residues and traces of cleaning solution and sterilise tubes that have been used previously before subsequent use.

### Assay Designs

Microbial assays gain markedly in precision by the segregation of relatively large sources of potential error and bias through suitable experimental designs. In a cylinder plate assay, the essential comparisons are restricted to relationships between zone diameter measurements within plates, exclusive of the variation between plates in their preparation and subsequent handling. To conduct a turbidimetric assay so that the difference in observed turbidity will reflect the differences in the antibiotic concentration requires both greater uniformity in the environment created for the tubes through closer thermostatic control of the incubator and the avoidance of systematic bias by a random placement of replicate tubes in separate tube racks, each rack containing one complete set of treatments. The essential comparisons are then restricted to relationships between the observed turbidities within racks.

Within these restrictions, two alternative designs are recommended; i.e. a 3-level (or 2-level) factorial assay, or a 1-level assay with a standard curve. For a factorial assay, prepare solutions of 3 or 2 corresponding test dilutions for both the standard and the unknowns on the day of the assay, as described under Preparation of the Standard and Preparation of the samples. For a 1-level assay with a standard curve, prepare instead solutions of five test dilutions of the standard and a solution of a single median test level of the unknown as described in the same sections. Consider an assay as preliminary if its computed potency with either design is less than 60 per cent or more than 150 per cent of that assumed in preparing the stock solution of the unknown. In such a case, adjust its assumed potency accordingly and repeat the assay.

Microbial determinations of potency are subject to inter-assay variables as well as intra-assay variables, so that two or more independent assays are required for a reliable estimate of the



potency of a given assay preparation or unknown. Starting with separately prepared stock solutions and test dilutions of both the standard and unknown, repeat the assay of a given unknown on a different day. If the estimated potency of the second assay differs significantly, as indicated by the calculated standard error, from that of the first, conduct one or more additional assays. The combined result of a series of smaller, independent assays spread over a number of days is a more reliable estimate of potency than that from a single large assay with the same total number of plates or tubes.

### Methods

Carry out the microbiological assay by Method A or Method B.

#### A. Cylinder-plate or Cup-plate method

Inoculate a previously liquefied medium appropriate to the assay (Tables 1 and 3) with the requisite quantity of suspension of the micro organism, add the suspension to the medium at a temperature between 40° and 50° and immediately pour the inoculated medium into the petri dishes or large rectangular plates to give a depth of 3 to 4 mm (1 to 2mm for nystatin). Ensure that the layers of medium are uniform in thickness, by placing the dishes or plates on a level surface.

Store the prepared dishes or plates in a manner so as to ensure that no significant growth or death of the test organism occurs before the dishes or plates are used and that the surface of the agar layer is dry at the time of use.

Using the appropriate buffer solutions indicated in Tables 2 and 3, prepare solutions of known concentrations of the standard preparation and solutions of the corresponding assumed of concentrations the antibiotic to be examined. Where directions have been given in the individual monograph for preparing the solutions, these should be followed and further dilutions made with buffer solution as indicated in Table 3. Apply the solutions to the surface of the solid medium in sterile cylinders or in cavities prepared in the agar. The volume of solution added to each cylinder or cavity must be uniform and sufficient almost to fill the holes when these are used. When paper discs are used these should be sterilised by exposure of both sides under a sterilising lamp and then impregnated with the standard solutions or the test solutions and placed on the surface of the medium. When Petri dishes are used, arrange the solutions of the Standard Preparation and the antibiotic under examination on each dish so that, they alternate around the dish and so that the highest concentrations of standard and test preparations are not adjacent. When plates are used, place the solutions in a Latin square design, if the plate is a square, or if it is not, in a randomised block design. The same random design should not be used repeatedly.

Leave the dishes or plates standing for 1 to 4 hours at room temperature or at 4°, as appropriate, as a period of pre-

incubation diffusion to minimise the effects of variation in time between the application of the different solutions. Incubate them for about 18 hours at the temperature indicated in Table 3. Accurately measure the diameters or areas of the circular inhibition zones and calculate the results.

Selection of the assay design should be based on the requirements stated in the individual monograph. Some of the usual assay designs are as follows.

#### (a) One-level assay with standard curve

**Standard Solution.** Dissolve an accurately weighed quantity of the Standard Preparation of the antibiotic, previously dried where necessary, in the solvent specified in Table 3, and then dilute to the required concentration, as indicated, to give the stock solution. Store in a refrigerator and use within the period indicated. On the day of the assay prepare from the stock solution, 5 dilution (solutions  $S_1$  to  $S_5$ ) representing 5 test levels of the standard and increasing stepwise in the ratio of 4:5. Use the diluent specified in Table 3 and a sequence such that the middle or median has the concentration given in the table.

**Sample Solution.** From the information available for the antibiotic preparation which is being examined (the “unknown”) assign to it an assumed potency per unit weight or volume and on this assumption prepare on the day of the assay a stock solution with same solvent as used for the standard. Prepare from this stock solution a dilution to a concentration equal to the median level of the standard to give the sample solution.

**Method.** For preparing the standard curve, use a total of 12 Petri dishes or plates to accommodate 72 cylinders or cavities. A set of 3 plates (18 cylinders or cavities) is used for each dilution. On each of the three plates of a set fill alternate cylinders or cavities with solution  $S_3$  (representing the median concentration of the standard solution) and each of the remaining 9 cylinders or cavities with one of the other 4 dilutions of the standard solution. Repeat the process for the other 3 dilutions of the standard solution. For each unknown preparation use a set of 3 plates (18 cylinders or cavities) and fill alternate cylinders or cavities with the sample solution and each of the remaining 9 cylinders or cavities with solution  $S_3$ .

Incubate the plates for about 18 hours at the specified temperature and measure the diameters or the zones of inhibition.

**Estimation of potency.** Average the readings of solution  $S_3$  and the readings of the concentration tested on each sets of three plates, and average also all 36 readings of solution  $S_3$ . The average of the 36 readings of solution  $S_3$  is the correction point for the curve. Correct the average value obtained for each concentration ( $S_1$ ,  $S_2$ ,  $S_4$  and  $S_5$ ) to the figure it would be if the readings for solution  $S_3$  for that set of three plates were

the same as the correction point. Thus, in correcting the value obtained with any concentration, say  $S_1$ , if the average of 36 readings of  $S_3$  is, for example, 18.0 mm and the average of the  $S_3$  concentrations on one set of three plates is 17.8 mm, the correction is + 0.2 mm. If the average reading of  $S_1$  is 16.0 mm the corrected reading of  $S_1$  is 16.2 mm. Plot these corrected values including the average of the 36 readings for solutions  $S_3$  on two-cycle semilog paper, using the concentrations in Units or  $\mu\text{g}$  per ml (as the ordinate logarithmic scale) and the diameter of the zones of inhibition as the abscissa. Draw the straight response line either through these points by inspection or through the points plotted for highest and lowest zone diameters obtained by means of the following expressions:

$$L = \frac{3a + 2b + c - e}{5}; \quad H = \frac{3e + 2d + c - a}{5}$$

where,  $L$  = the calculated zone diameter for the lowest concentration of the standard curve response line.

$H$  = the calculated zone diameter for the highest concentration of the standard curve response line.

$c$  = average zone diameter of 36 readings of the reference point standard solution.

$a, b, d, e$  = corrected average values for the other standard solutions, lowest to highest concentrations, respectively.

Average the zone diameters for the sample solution and for solutions  $S_3$  on the plates used for the sample solution. If sample gives a large average zone size than the average of the standard (solution  $S_3$ ), add the difference between them to the zone size of solution  $S_3$  of the standard response line. If the average sample zone size is smaller than the standard values, subtract the difference between them from the zone size of solution  $S_3$  of the standard response line. From the response line read the concentration corresponding to these corrected values of zone sizes. From the dilution factors the potency of the sample may be calculated.

#### (b) Two-level factorial assay

Prepare parallel dilutions containing 2 levels of both the standard ( $S_1$  and  $S_2$ ) and the unknown ( $U_1$  and  $U_2$ ). On each of four or more plates, fill each of its four cylinders or cavities with a different test dilution, alternating standard and unknown. Keep the plates at room temperature and measure the diameters of the zones of inhibition.

**Estimation of potency.** Sum the diameters of the zones of each dilution and calculate the percentage potency of the sample (in terms of the standard) from the following equation :

$$\text{Per cent potency} = \text{Antilog} (2.0 + a \log I)$$

wherein  $a$  may have a positive or negative value and should be used algebraically and

$$\text{where } a = \frac{(U_1 + U_2) - (S_1 + S_2)}{(U_1 - U_2) + (S_1 - S_2)}$$

$U_1$  and  $U_2$  are the sums of the zone diameters with solutions of the unknown of high and low levels.

$S_1$  and  $S_2$  are the sums of the zone diameters with solutions of the standard of high and low levels.

$I$  = ratio of dilutions.

If the potency of the sample is lower than 60 per cent or greater than 150 per cent of the standard, the assay is invalid and should be repeated using higher or lower dilutions of the same solution.

The potency of the sample may be calculated from the expression

$$\frac{\text{per cent potency} \times \text{assumed potency of the sample}}{100}$$

#### (c) Other designs

1. Factorial assay containing parallel dilution of three test levels of standard and the unknown.
2. Factorial assay using two test levels of standard and two test levels of two different unknowns.

#### B. Turbidimetric or Tube assay method

The method has the advantage of a shorter incubation period for the growth of the test organism (usually 3 to 4 hours) but the presence of solvent residues or other inhibitory substances affects this assay more than the cylinder plates assay and care should be taken to ensure freedom from such substances in the final test solutions. This method is not recommended for cloudy or turbid preparations.

Prepare five different concentrations of the standard solution for preparing the standard curve by diluting the stock solution of the Standard Preparation of the antibiotic (Table 3) and increasing stepwise in the ration 4:5. Select the median concentration (Table 3) and dilute the solution of the substance being examined (unknown) to obtain approximately this concentration. Place 1 ml of each concentration of the standard solution and of the sample solution in each of the tubes in duplicate. To each tube add 9 ml of nutrient medium (Table 3) previously seeded with the appropriate test organism (Table 3).

At the same time prepare three control tubes, one containing the inoculated culture medium (culture control), another identical with it but treated immediately with 0.5 ml of *dilute*



*formaldehyde solution* (blank) and a third containing uninoculated culture medium.

Place all the tubes, randomly distributed or in a randomized block arrangement, in an incubator or water-bath and maintain them at the specified temperature (Table 3) for 3 to 4 hours. After incubation add 0.5 ml of *dilute formaldehyde solution* to each tube. Measure the growth of the test organism by determining the absorbance at about 530 nm of each of the solutions in the tubes against the blank (2.4.7).

**Estimation of potency.** Plot the average absorbances for each concentration of the standard on *semi-logarithmic* paper with the absorbances on the arithmetic scale and concentrations on the logarithmic scale. Construct the best straight response line through the points either by inspection or by means of the following expressions:

$$L = \frac{3a + 2b + c - e}{5}; \quad H = \frac{3e + 2d + c - a}{5}$$

where, L = the calculated absorbance for the lowest concentration of the standard response line.

H = the calculated absorbance for the highest concentration of the standard response line.

*a, b, c, d, e* = average absorbance values for each concentration of the standard response line lowest to highest respectively.

Plot the values obtained for L and H and connect the points. Average the absorbances for the sample and read the antibiotic concentration from the standard response line. Multiply the concentration by the appropriate dilution factors to obtain the antibiotic content of the sample.

### Precision of Microbiological Assays

The fiducial limits of error of the estimated potency should be not less than 95 per cent and not more than 105 per cent of the estimated potency unless otherwise stated in the individual monograph.

This degree of precision is the minimum acceptable for determining that the final product complies with the official requirements and may be inadequate for those deciding, for example, the potency which should be stated on the label or used as the basis for calculating the quantity of an antibiotic to be incorporated in a preparation. In such circumstances, assays of greater precision may be desirable with, for instance, fiducial limits of error of the order of 98 per cent to 102 per cent. With this degree of precision, the lower fiducial limit lies close to the estimated potency. By using this limit, instead of the estimated potency, to assign a potency to the antibiotic either for labelling or for calculating the quantity to be included

in a preparation, there is less likelihood of the final preparation subsequently failing to comply with the official requirements for potency.

### 2.2.11. Sterility

The test for sterility is applied to pharmacopoeial articles that are required according to the Pharmacopoeia to be sterile. However, a satisfactory result only indicates that no contaminating viable micro-organisms have been found in the sample examined in the conditions of the test. If the number of micro-organisms present in a given amount of the article under examination is large, the probability of detecting them increases. Very low levels of contamination cannot be detected on the basis of random sampling of a lot. Moreover, if contamination is not uniform throughout the lot, random sampling cannot detect contamination with any certainty. Compliance with the test for sterility alone cannot therefore provide absolute assurance of freedom from microbial contamination. Greater assurance of sterility must come from reliable manufacturing procedures and compliance with good manufacturing practices.

The test must be carried out under aseptic conditions designed to avoid accidental contamination of the product during testing. For achieving these conditions, a grade A laminar air-flow cabinet or an isolator is recommended. The test environment has to be adapted to the way in which the tests are performed. Precautions taken for this purpose should not adversely affect any micro-organisms, which are to be revealed in the tests. The working conditions in which the tests are carried out should be monitored regularly by appropriate sampling of the air and surfaces of the working area and by carrying out control tests.

The test is designed to reveal the presence of micro-organisms in the samples used in the test; interpretation of the results of testing is based on the assumption that all units of an article or the entire bulk product or the contents of every container of the filled product in a lot or batch, had they been tested, would also have given the same results. Since all the units or the bulk or all the containers cannot be tested, a sufficient number of samples of units or of containers should be examined to give a suitable degree of confidence in the results of the tests.

No sampling plan for applying the tests to a specified proportion of discrete units selected from a batch is capable of demonstrating that all of the untested units are in fact sterile. Therefore, in determining the number of units to be tested, the manufacturer should have regard to the environmental conditions of manufacture, the volume of preparation per container and other special considerations particular to the preparation being examined. Table 1 gives guidance on the minimum number of items recommended to be tested in relation

to the number of items in the batch on the assumption that the preparation has been manufactured under conditions designed to exclude contamination.

Table 1

Number of items in the batch	Minimum number of items recommended to be tested
<b>1. Parenteral preparations</b>	
Not more than 100 containers	10 per cent or 4 containers, whichever is greater
More than 100 but not more than 500 containers	10 containers
More than 500 containers	2 per cent or 20 containers, whichever is less
For large-volume parenterals	2 per cent or 20 containers, whichever is less
<b>2. Ophthalmic and other non-parenteral preparations</b>	
Not more than 200 containers	5 per cent or 2 containers, whichever is greater
More than 200 containers	10 containers
<b>3. Surgical dressings and devices</b>	
Catgut, surgical sutures and other sterile medical devices for use	2 per cent or 5 packages, whichever is greater, up to a maximum of 20 packages
Not more than 100 packages	10 per cent or 4 packages, whichever is greater
More than 100 but not more than 500 packages	10 packages
More than 500 packages	2 per cent or 20 packages, whichever is less
<b>4. Bulk solids</b>	
Less than 4 containers	Each container
4 containers but not more than 50 containers	20 per cent or 4 containers, whichever is greater
More than 50 containers	2 per cent or 10 containers, whichever is greater

### Culture Media

Media for the tests may be prepared as described below, or equivalent commercially available dehydrated mixtures yielding

similar formulations may be used provided that when reconstituted as directed by the manufacturer, they comply with the growth promotion test. Other media may be used provided that they have been shown to sustain the growth of a wide range of micro-organisms.

The following culture media have been found to be suitable for the test. Fluid thioglycollate medium is primarily intended for the culture of anaerobic bacteria; however, it will also detect aerobic bacteria. Soyabean-casein digest medium is suitable for the culture of both fungi and aerobic bacteria.

**Fluid Thioglycollate Medium** – For use with clear fluid products.

L-Cystine	0.5 g
Sodium chloride	2.5 g
Dextrose monohydrate/anhydrous	5.5 g/5.0 g
Granular agar (moisture content less than 15 per cent, w/w)	0.75 g
Yeast extract (water-soluble)	5.0 g
Pancreatic digest of casein	15.0 g
Sodium thioglycollate or Thioglycollic acid	0.5 g 0.3 ml
Resazurin sodium solution (0.1 per cent), freshly prepared	1.0 ml
Distilled water to	1000 ml
pH of the medium after sterilisation	7.1 ± 0.2

Mix the ingredients other than the thioglycollate or thioglycollic acid and the resazurin sodium solution, in the order given above, in a mortar, with thorough grinding. Stir in some heated *distilled water*, transfer to a suitable container, add the remainder of the *distilled water*, and complete the solution by heating in a boiling water-bath. Dissolve the sodium thioglycollate or thioglycollic acid in the solution and, if necessary, add *1M sodium hydroxide* so that, after sterilisation, the solution will have a pH of 7.1 ± 0.2. If filtration is necessary, heat the solution again without boiling and filter while hot through moistened filter paper. Add the resazurin sodium solution, mix and distribute the medium into suitable vessels that provide a ratio of surface to depth of medium such that not more than the upper half of the medium has undergone a colour change indicative of oxygen uptake at the end of the incubation period. Sterilise in an autoclave at 121° for 20 minutes. If the medium is to be stored, cool promptly to 25° and store at 2° to 30°, avoiding excess of light. If more than the upper one-third of the medium has acquired a pink colour, the medium may be restored *once* by reheating in a water-bath or in free-flowing steam until the pink colour disappears, and cooling rapidly, taking care to prevent the introduction of non-sterile air into the container. When ready for use, not

more than the upper one-tenth of the medium should have a pink colour. Medium more than 4 weeks old should not be used.

Use fluid thioglycollate medium by incubating it at 30° to 35°.

**Alternative Thioglycollate Medium** — For use with turbid and viscid products and for devices having tubes with small lumina.

L-Cystine	0.5 g
Sodium chloride	2.5 g
Dextrose monohydrate/anhydrous	5.5 g/5.0 g
Yeast extract (water-soluble)	5.0 g
Pancreatic digest of casein	15.0 g
Sodium thioglycollate or	0.5 g
Thioglycollic acid	0.3 ml
Distilled water to	1000 ml
pH of the medium after sterilisation	7.1 ± 0.2

Heat the ingredients in a suitable container until solution is effected. Mix, add *1M sodium hydroxide*, if necessary, so that, after sterilisation, the medium will have a pH of 7.1 ± 0.2. Filter, if necessary, place in suitable vessels and sterilise at 121° for 20 minutes. Store at a temperature between 2° and 25° in a sterile sealed container, unless it is intended for immediate use.

The medium is freshly prepared or heated in a water-bath and allowed to cool just prior to use. It should not be reheated.

Use alternative thioglycollate medium in a manner that will assure anaerobic conditions for the duration of the incubation at 30° to 35°.

#### **Soyabean-casein Digest Medium**

Pancreatic digest of casein	17.0 g
Papaic digest of soyabean meal	3.0 g
Sodium chloride	5.0 g
Dipotassium hydrogen phosphate (K <sub>2</sub> HPO <sub>4</sub> )	2.5 g
Dextrose monohydrate/anhydrous	2.5 g/2.3 g
Distilled water to	1000 ml
pH of the medium after sterilisation	7.3 ± 0.2

Dissolve the solids in *distilled water*, warming slightly to effect solution. Cool to room temperature and add, if necessary, sufficient *1M sodium hydroxide* so that after sterilisation the medium will have a pH of 7.3 ± 0.2. Filter, if necessary, distribute into suitable containers and sterilise in an autoclave at 121° for 20 minutes.

Use soyabean-casein digest medium by incubating it at 20° to 25° under aerobic conditions.

#### **Media for Penicillins and Cephalosporins**

Where sterility test media are to be used in Method B described under Test Procedures modify the preparation of fluid thioglycollate medium and the soyabean-casein digest medium as follows. To the containers of each medium, transfer aseptically a quantity of penicillinase sufficient to inactivate the amount of antibiotic in the sample under test. Determine the appropriate quantity of penicillinase to be used for this purpose by using a penicillinase preparation that has been assayed previously for its penicillin- or cephalosporin-inactivating power.

*NOTE* — *Supplemented penicillinase media can also be used in Method A.*

Alternatively (in an area completely separate from that used for sterility testing) confirm that the appropriate quantity of penicillinase is incorporated into the medium, following either method under Validation of Tests, using less than 100 CFU of *Staphylococcus aureus* (ATCC 29737) as the challenge. Typical microbial growth of the inoculated culture must be observed as a confirmation that the penicillinase concentration is appropriate.

#### **Suitability of Media**

The media used should comply with the following tests, carried out before or in parallel with the test on the preparation under examination.

**Sterility.** Incubate portions of the media for 14 days at the temperatures indicated under each medium. No growth of micro-organisms occurs.

**Growth Promotion Test.** Test each autoclaved load of each lot of the medium for its growth-promoting qualities using suitable strains of micro-organisms indicated in Table 2.

Inoculate duplicate portions of each medium with a small number (not more than 100 CFU) of the micro-organisms specified, using separate portions of the medium for each of the micro-organisms and incubating according to the conditions specified in Table 2.

The media are suitable if a clearly visible growth of the micro-organisms occurs. The tests may be conducted simultaneously with any *test for sterility* done using the same lot of media. However, such tests will be considered invalid if the test media show inadequate growth response.

If freshly prepared media are not used within 2 days, they should be stored in the dark, preferably at 2° to 25°. Finished media, if stored in unsealed containers, may be used for not more than one month provided they are tested within one week of use.

**Validation of Tests.** Carry out a test as described under Test Procedures using exactly the same methods with the following modifications.

Table 2

Medium	Test micro-organism	Incubation		
		Temp (° )	Duration	Type of micro-organism
Fluid Thioglycollate	1. <i>Bacillus subtilis</i> (ATCC <sup>1</sup> 6633; NCIMB <sup>2</sup> 8054)	30 to 35	3 days	Aerobic
	2. <i>Staphylococcus aureus</i> (ATCC 6538)	30 to 35	3 days	Aerobic
	3. <i>Pseudomonas aeruginosa</i> (ATCC 9027) <sup>3</sup>	30 to 35	3 days	Aerobic
Alternative Thioglycollate	1. <i>Bacteroides vulgatus</i> (ATCC 8482) <sup>4</sup>	30 to 35	3 days	Anaerobic
	2. <i>Clostridium sporogenes</i> (ATCC 19404)	30 to 35	3 days	Anaerobic
Soyabean-Case.in Digest	1. <i>Aspergillus niger</i> (ATCC 16404)	20 to 25	5 days	Aerobic
	2. <i>Candida albicans</i> (ATCC 10231; ATCC 2091; NCYC <sup>5</sup> 854)	20 to 25	5 days	Aerobic

1. Available from the American Type Culture Collection, 12301 Parklawn Drive, Rockville, MD 20852, USA.

2. Available from National Collection of Industrial and Marine Bacteria Ltd, 23 St Machar Drive, Aberdeen, AB2 1RY, Scotland.

3. An alternative micro-organism is *Micrococcus luteus* (ATCC No. 9341).

4. If a spore-forming organism is desired, use *Clostridium sporogenes* (ATCC No. 11437) at the incubation temperatures indicated in the Table.

5. Available from National Collection of Yeast Cultures, AFRC Food Research Institute, Colney Lane, Norwich NR4 7UA, England

NOTE — Seed lot culture maintenance techniques (seed-lot systems) should be used so that the viable micro-organisms used for inoculation are not more than 5 passages removed from the original master seed-lot.

**Membrane Filtration.** After transferring the contents of the container or containers to be tested to the membrane add an inoculum of a small number of viable micro-organisms (not more than 100 CFU) to the final portion of sterile diluent used to rinse the filter.

**Direct Inoculation.** After transferring the contents of the container or containers to be tested to the culture medium add an inoculum of a small number of viable micro-organisms (not more than 100 CFU) to the medium.

In both cases use the same micro-organisms as those described under Growth Promotion Test. Perform a growth promotion test as a positive control. Incubate all the containers containing medium for not more than 5 days.

If clearly visible growth of micro-organisms is obtained after the inoculation, visually comparable to that in the control vessel without product, either the product possesses no antimicrobial activity under the conditions of the test or such activity has been satisfactorily eliminated. The test for sterility may then be carried out without further modification.

If clearly visible growth is not obtained in the presence of the product under examination, visually comparable to that in the control vessels without product, the product possesses antimicrobial activity that has not been satisfactorily eliminated under the conditions of the test. A suitable sterile neutralising agent may be used where the preparation under examination has antimicrobial activity. If a neutralising agent is not available,

modify the amounts of the preparation and medium to be used in order to eliminate antimicrobial activity and repeat the validation test. Where the specified amounts of the preparation have antimicrobial activity in the medium, increase the quantities of medium so that the specified quantity of the preparation is sufficiently diluted to prevent inhibition of growth.

This validation is performed

- when the test for sterility has to be carried out on a new product,
- whenever there is a change in the experimental conditions of the test.

The validation may be performed simultaneously with the test for sterility of the substance or preparation under examination.

### Test Procedures

Either of the following methods, Method A – Membrane Filtration or Method B – Direct Inoculation, may be followed. Method A is to be preferred where the substance under examination is (a) an oil, (b) an ointment that can be put into solution, (c) a non-bacteriostatic solid not readily soluble in the culture medium, and (d) a soluble powder or a liquid that possesses bacteriostatic and/or fungistatic properties.

For liquid products where the volume in a container is 100 ml or more, Method A should be used.



Select the number of samples to be tested from Table 1 and use them for the culture medium for bacteria and the culture medium for fungi.

**General.** The exterior surface of ampoules and closures of vials and bottles should be cleaned with a suitable antimicrobial agent and access to the contents should be gained in a suitable aseptic manner. If the contents are packed in a container under vacuum, sterile air should be admitted by means of a suitable sterile device, such as a needle attached to a syringe barrel filled with non-absorbent cotton.

#### Method A – Membrane Filtration

The method calls for the routine use of positive and negative controls. A suitable positive control is the occasional use of a known contaminated solution containing a few micro-organisms of different types (approximately 10 CFU in the total volumes employed).

#### Apparatus

A suitable unit consists of a closed reservoir and a receptacle between which a properly supported membrane of appropriate porosity is placed. A membrane generally suitable for sterility testing has a nominal pore size not greater than 0.45  $\mu$  and diameter of approximately 50 mm, the effectiveness of which in retaining micro-organisms has been established. Cellulose nitrate filters are used for aqueous, oily and weakly alcoholic solutions and cellulose acetate filters, for strongly alcoholic solutions. Preferably assemble and sterilise the entire unit with the membrane in place prior to use. Where the sample to be tested is an oil, sterilise the membrane separately and, after thorough drying, assemble the unit using aseptic precautions.

#### Diluting Fluids

**Fluid A.** Dissolve 1 g of peptic digest of animal tissue (such as bacteriological peptone) or its equivalent in *water* to make 1 litre, filter or centrifuge to clarify, adjust to pH  $7.1 \pm 0.2$ , dispense into flasks in 100-ml quantities and sterilise at  $121^\circ$  for 20 minutes.

*NOTE* — Where fluid A is to be used in performing the test for sterility on a specimen of the penicillin or cephalosporin class of antibiotics, aseptically add a quantity of sterile penicillinase to the fluid A to be used to rinse the membrane(s) sufficient to inactivate any residual antibiotic activity on the membrane(s) after the solution of the specimen has been filtered.

**Fluid B.** If the test sample contains lecithin or oil, use fluid A to each litre of which has been added 1 ml of polysorbate 80, adjust to pH  $7.1 \pm 0.2$ , dispense into flasks and sterilise at  $121^\circ$  for 20 minutes.

*NOTE* — A sterile fluid shall not have antibacterial or antifungal properties if it is to be considered suitable for

*dissolving, diluting or rinsing a preparation being examined for sterility.*

#### Quantities of Sample to be used

**For parenteral preparations.** Whenever possible use the whole contents of the container, but in any case not less than the quantities prescribed in Table 3, diluting where necessary to about 100 ml with a suitable diluent such as fluid A.

**For ophthalmic and other non-parenteral preparations.** Take an amount within the range prescribed in column (A) of Table 4, if necessary, using the contents of more than one container, and mix thoroughly. For each medium use the amount specified in column (B) of Table 4, taken from the mixed sample.

#### Method of Test

**For aqueous solutions.** Prepare each membrane by aseptically transferring a small quantity (sufficient to moisten the membrane) of fluid A on to the membrane and filter it. For each medium to be used, transfer aseptically into two separate membrane filter funnels or to separate sterile pooling vessels prior to transfer not less than the quantity of the preparation under examination that is prescribed in Table 3 or Table 4. Alternatively, transfer aseptically the combined quantities of the preparation under examination prescribed in the two media onto one membrane. Draw the liquid rapidly through the filter with the aid of vacuum. If the solution under examination has antimicrobial properties, wash the membrane(s) by filtering through it (them) not less than three successive quantities, each of 100 ml, of sterile fluid A. Do not exceed a washing cycle of 5 times or 200 ml, even if it has been demonstrated during validation that such a cycle does not fully eliminate the antimicrobial activity. The quantities of fluid used should be sufficient to allow growth of a small inoculum of organisms (approximately 50 CFU) sensitive to the antimicrobial substance in the presence of the residual inhibitory material on the membrane.

After filtration, aseptically remove the membrane(s) from the holder, transfer the whole membrane or cut it aseptically into 2 equal parts. Transfer one half to each of two suitable media. Use the same volume of each medium as in the procedure for

**Validation of Tests.** Alternatively, transfer the medium onto the membrane in the apparatus. Incubate the media for not less than 14 days.

Observe the containers of media periodically during the 14 days of incubation. If the test specimen is positive before 14 days of incubation, further incubation is not necessary. For products terminally sterilised by a validated moist heat process, incubate the test specimen for not less than 7 days.

**For liquids immiscible with aqueous vehicles, and suspensions.** Carry out the test described under For aqueous solutions but add a sufficient quantity of fluid A to the pooled

sample to achieve rapid filtration. Sterile enzyme preparations such as penicillinase or cellulase may be added to fluid A to aid in dissolving insoluble substances. If the substance being examined contains lecithin, use fluid B for diluting.

**For oils and oily solutions.** Filter oils or oily solutions of sufficiently low viscosity without dilution through a dry

membrane. Dilute viscous oils as necessary with a suitable sterile diluent such as *isopropyl myristate* that has been shown not to have antimicrobial properties under the conditions of the test. Allow the oil to penetrate the membrane and filter by applying pressure or by suction, gradually. Wash the membrane by filtering through it at least three successive

Table 3

Quantity in each container of injectable preparation	Minimum quantity to be used for each culture medium
<i>For liquids</i>	
Less than 1 ml	Total contents of a container
1 ml or more but less than 40 ml	Half the contents of a container
40 ml or more but less than 100 ml	20 ml
100 ml or more	10 per cent of the contents of a container but not less than 20 ml
<i>Antibiotic liquids</i>	1 ml
<i>Other preparations soluble in water or in isopropyl myristate</i>	The whole contents of each container to provide not less than 200 mg
<i>Insoluble preparations, creams and ointments to be suspended or emulsified</i>	The whole contents of each container to provide not less than 200 mg
<i>For solids</i>	
Less than 50 mg	Total contents of a container
50 mg or more but less than 300 mg	Half the contents of a container
300 mg or more	100 mg
<i>For catgut and other surgical sutures for veterinary use</i>	3 sections of a strand (each 30 cm long)
<i>For surgical dressings/cotton/gauze (in packages)</i>	100 mg per package
<i>For sutures and other individually packed single use materials</i>	The whole device or material, cut into pieces or disassembled

Table 4

Type of preparation	Quantity to be mixed (A)	Quantity to be used for each culture medium (B)
Ophthalmic solutions; other than non-parenteral liquid preparations	10 to 100 ml	5 to 10 ml
Other preparations; preparations soluble in water or appropriate solvents; insoluble preparations to be suspended or emulsified (ointments and creams)	1 to 10 g	0.5 to 1 g
Absorbent cotton		Not less than 1 g*

\* One portion

quantities, each of approximately 100 ml, of sterile fluid B or any other suitable sterile diluent. Complete the test described under

For aqueous solutions, beginning at the words “After filtration,.....”.

**For ointments and creams.** Dilute ointments in a fatty base and emulsions of the water-in-oil type to give a fluid concentration of 1 per cent w/v, by heating, if necessary, to not more than 40° with a suitable sterile diluent such as *isopropyl myristate* previously rendered sterile by filtration through a 0.22 µm membrane filter that has been shown not to have antimicrobial properties under the conditions of the test. Filter as rapidly as possible and complete the test as described under For oils and oily solutions, beginning at the words “Wash the membrane by .....”. In exceptional cases, it may be necessary to heat the substance to not more than 44° and to use warm solutions for washing the membrane.

*NOTE — For ointments and oils that are insoluble in isopropyl myristate, use Method B.*

**For soluble solids.** For each medium, dissolve not less than the quantity of the substance under examination, as prescribed in Tables 3 and 4, in a suitable sterile solvent such as fluid A and carry out the test described under For aqueous solutions using a membrane appropriate to the chosen solvents.

**For solids for injection other than antibiotics.** Constitute the test articles as directed on the label, and carry out the test as described under For aqueous solutions or For oils and oily solutions, as applicable.

*NOTE — If necessary, excess diluent may be added to aid in the constitution and filtration of the constituted article.*

**For antibiotic solids, bulks, and blends.** Aseptically remove a sufficient quantity of solids from the appropriate amount of containers prescribed in Table 3, mix to obtain a composite sample, equivalent to about 6 g of solids, and transfer to a sterile flask. Dissolve in about 200 ml of fluid A, and mix. Carry out the test as described under For aqueous solutions.

**For antibiotics in packages of 5 g or less.** From each of 20 containers, aseptically transfer about 300 mg of solids into a sterile flask, dissolve in about 200 ml of fluid A and mix, or constitute as directed on the label of containers and transfer a quantity of liquid or suspension, equivalent to about 300 mg of solids into a sterile flask, dissolve in about 200 ml of fluid A, and mix. Carry out the test as described under For aqueous solutions or For oils and oily solutions, as appropriate.

**For sterile devices.** Aseptically pass a sufficient volume of fluid B through each of not less than 20 devices so that not less than 100 ml is recovered from each device. Collect the fluids in sterile containers and filter the entire volume through the membrane filter funnel(s) as described under For aqueous solutions.

In the case of sterile, empty syringes, draw sterile diluent into the barrel through the sterile needle, if attached, or through a sterile needle attached for the purpose of the test and express the contents into a sterile polling vessel. Proceed as directed above.

For catheters where the inside lumen and outside surface are required to be sterile, either cut them into pieces such that the medium is in contact with the entire lumen or full the lumen with medium and then immerse the intact unit.

### Method B – Direct Inoculation

#### Quantities of Sample to be used

The quantity of the substance or preparation under examination to be used for inoculation in the culture media varies according to the quantity in each container. Follow the directions given in Table 3.

#### Method of Test

**For aqueous solutions and suspensions.** Remove the liquid from the test containers with a sterile pipette or with a sterile syringe or a needle. Transfer the quantity of the preparation under examination prescribed in Table 4 directly into the culture medium so that the volume of the preparation under examination is not more than 10 per cent of the volume of the medium, unless otherwise prescribed. When the quantity in a single container is insufficient to carry out the tests, the combined contents of two or more containers are to be used to inoculate the media.

If the preparation under examination has antimicrobial activity, carry out the test after neutralising this with a suitable neutralising substance or by dilution in a sufficient quantity of culture medium. When it is necessary to use a large volume of the product it may be preferable to use a concentrated culture medium prepared in such a way that it takes account of the subsequent dilution. Where appropriate, the concentrated medium may be added directly to the product in its container.

Incubate the inoculated media for not less than 14 days. Observe the cultures several times during the incubation period. Observe the containers of media periodically during the 14 days of incubation. If the test specimen is positive before 14 days of incubation, further incubation is not necessary. For products terminally sterilised by a validated moist heat process, incubate the test specimen for not less than 7 days.

**For oils and oily solutions.** Use media to which has been added a suitable emulsifying agent at a concentration shown to be appropriate in the validation of the test, for example, *polysorbate 80* at a concentration of 10g/l and which has been shown not to have any antimicrobial properties under



the conditions of the test. Carry out the test as described under For aqueous solutions and suspensions.

During the incubation period shake the cultures gently each day. However, when thioglycollate medium or other similar medium is used for the detection of anaerobic micro-organisms keep shaking or mixing to a minimum in order to maintain anaerobic conditions.

**For ointments and creams.** Prepare by diluting to about 1 in 10 by emulsifying with the chosen emulsifying agent in a suitable sterile diluent such as fluid A. Transfer the diluted product to a medium not containing an emulsifying agent. (Before use, test the emulsifying agent to ascertain that in the concentration used it has no significant antimicrobial effects during the time interval for all transfers). Mix 10 ml of the fluid mixture so obtained with 80 ml of the medium and proceed as directed under For aqueous solutions and suspensions.

**For solids.** Transfer the quantity of the preparation under examination to the quantity of medium specified in Table 4 and mix. Proceed as directed under For aqueous solutions and suspensions.

**For surgical dressings and related articles.** From each package under examination, aseptically remove two or more portions of 100 to 500 mg each from the innermost part of the sample. From individually packaged, single-use materials, aseptically remove the entire article. Immerse the portions or article in each medium, and proceed as directed under For aqueous solutions and suspensions.

**For sterile devices.** For articles of such size and shape that permit complete immersion in not more than 1000 ml of the culture medium, test the article, using the appropriate media, and proceed as directed under For aqueous solutions and suspensions.

### Observation and Interpretation of Results

At intervals during the incubation period and at its conclusion, examine the media for macroscopic evidence of microbial growth. If the material being tested renders the medium turbid so that the presence or absence of microbial growth cannot be easily determined by visual examination, 14 days after the beginning of incubation, transfer portions (each not less than 1 ml) of the medium to fresh vessels of the same medium and then incubate the original and transfer vessels for not less than 4 days.

If no evidence of microbial growth is found, the preparation under examination complies with the test for sterility. If evidence of microbial growth is found, the preparation under examination does not comply with the test for sterility. Do not repeat the test unless it can be clearly shown that the test was invalid for causes unrelated to the preparation under examination. The test may be considered invalid only when one or more of the following conditions are fulfilled:

- (a) microbial growth is found in the negative controls;
- (b) data on microbial monitoring of the sterility testing facility show a fault;
- (c) a review of the testing procedure used for the test in question reveals a fault;
- (d) after identifying the micro-organisms isolated from the containers showing microbial growth, the growth may be ascribed without any doubt to faults with respect to the materials and/or technique used in conducting the test procedure.

If the test is declared to be invalid, repeat with the same number of units as in the original test. If no evidence of microbial growth is found in the repeat test, the preparation under examination complies with the test for sterility. If microbial growth is found in the repeat test and confirmed microscopically, the preparation under examination does not comply with the test for sterility.

### 2.2.12. Thiomersal

**Standard Preparation.** Weigh accurately about 0.1 g of *thiomersal*, previously dried over *phosphorus pentoxide* at a pressure not exceeding 2 kPa for 24 hours, and dissolve in sufficient *water* to produce 1000 ml. Prepare just before use dilutions of this solution with *water* to produce standard solutions containing in each ml 5.0 µg (low level) and 10.0 µg (high level) of thiomersal.

#### Test Medium

Pancreatic digest of casein	10.0 g
Beef extract	3.0 g
Yeast extract	1.5 g
Agar	15.0 g
Sodium chloride	3.0 g
Sucrose	1.0 g
Water to	1000 ml

Dissolve with the aid of heat, adjust the pH to 7.4 to 7.6 and sterilise by maintaining at 121° for 20 minutes.

#### Test organism

The test organism recommended for this assay is *Micrococcus flavus* (ATCC 10240; NCIB 8994).

#### Preparation of Inoculum and Assay Plates

Maintain the test organism by regular sub-culturing on slopes of the test medium. After incubation at 30° for 18 to 24 hours, emulsify the growth in about 10 ml of sterile *normal saline*.

To 150 ml of the test medium kept at a temperature of 46° to 48° add 1.5 ml of the well-shaken inoculum, swirl gently and mix

well. Immediately pour the inoculated medium into Petri dishes or large rectangular plates to give a depth of 3 to 4 mm. Cool and transfer to a cold place until the medium is set. Prior to use, prepare cavities approximately 8 mm in diameter in the solid medium.

#### Procedure

From an accurately measured volume of the preparation under examination prepare sample solutions containing two levels, namely about 5 µg and 10 µg of thiomersal and carry out method A, Cylinder-plate or Cup-plate Method, two-level factorial assay described under microbiological assay of antibiotics (2.2.10), incubating the plates at 30° for about 18 hours.

Calculate the result by standard statistical methods. The fiducial limits of error are not less than 90 per cent and not more than 100 per cent of the estimated value.

If the value obtained for the samples is lower than 50 per cent or greater than 150 per cent of the standard, the determination is invalid and should be repeated using higher or lower dilutions of the sample solution.

### 2.2.13. Urinary Excretion of Dextran

Place two rabbits in separate metabolism cages and collect the urine of each for 48 hours. Into the marginal ear vein of each rabbit inject over a period of 5 to 10 minutes a dose of 20 ml per kg of body weight of the preparation under examination and collect the urine excreted in the first 48 hour after injection. All the urine should be collected in clean glass vessels under *toluene*. Measure the total volume excreted by each of the rabbits and filter the urine.

Dialyse through a suitable membrane 10 ml of each sample of urine against running water for 24 hours and against *water* for further 24 hours. Transfer to a 25-ml volumetric flask by means of a Pasteur pipette, rinse the membrane with 6 to 8 ml of *water* and dilute the combined urine and rinsings to 25ml with *water*. To 3.0 ml of this solution, or a suitable volume diluted to 3.0 ml with *water* in a test-tube cooled in *water*, add carefully 6.0 ml of a 0.2 per cent w/v solution of *anthrone* in a mixture of 19 volumes of *sulphuric acid* and 1 volume of *water* so that the solutions form layers. Mix the contents of the tube immediately, place in a water-bath and heat for 5 minutes with precautions against loss of water by evaporation. Cool and compare the colour of the solution with that of the blank prepared in the same manner from 3.0 ml of *water* using a colorimeter fitted with a red filter. Determine the apparent amount of dextrose in the solution from a reference curve prepared by treating 3.0-ml quantities of solutions of *anhydrous dextrose* by the same process (suitable amounts of dextrose for this purpose are 15,30,60 and 90 µg per 3.0 ml).

Calculate the percentage of dextrans for each rabbit from the expression

$$90(x-y)/w$$

where, x = the total apparent amount of dextrose, in mg excreted in the first 48 hours after injection.

y = the total apparent amounts of dextrose, in mg excreted in the 48 hours before injection.

w = weight, in mg, of dextrans injected.

The result of the test is determined on the mean of the result for the two rabbits and must not exceed 30 per cent.

### 2.2.14. Immunochemical Methods

Immunochemical methods are based on the selective, reversible and non-covalent binding of antigens by antibodies. These methods are employed to detect or quantify either antigens or antibodies. The formation of an antigen antibody complex may be detected, and the amount of complex formed may be measured by a variety of techniques. The provisions of this general method apply to immunochemical methods using labelled or unlabelled reagents, as appropriate.

The results of the immunochemical methods depend on the experimental conditions and the nature and quality of the reagents used. It is essential to standardize the components of the immunoassay and to use, wherever available international reference preparations for immunoassays.

The reagents necessary for many immunochemical methods are available as commercial assay kits, that is, a set including reagents (particularly the antigen or the antibody) and materials intended for the *in vitro* estimation of a specified substance as well as instructions for their proper use. The kits are used in accordance with the manufacturers' instructions, it is important to ascertain that the kits are suitable for the analysis of the substance under examination, with particular reference to selectivity and sensitivity. Guidance concerning immunoassay kits is provided by the World Health Organisation, Technical Series 658 (1981).

#### Methods in which a labelled antigen or a labelled antibody is used

Methods using labelled substances may employ suitable labels such as enzymes, fluorophores, luminophores and radioisotopes. Where the label is a radioisotope, the method is described as a "radio-immunoassay". All work with radioactive materials must be carried out in conformity with national legislation and internationally accepted codes of practice for protection against radiation hazards.

#### Methods in which an unlabelled antigen or antibody is used

##### Immunoprecipitation methods

Immunoprecipitation methods include flocculation and precipitation reactions. When a solution of an antigen is

mixed with its corresponding antibody under suitable conditions, the reactants form flocculating or precipitating aggregates. The ratio of the reactants which gives the shortest flocculation time or the most marked precipitation is called the optimal ratio, and is usually produced by equivalent amounts of antigen and antibody. Immunoprecipitation can be assessed visually or by light-scattering techniques (nephelometric or turbidmetric assay). An increase in sensitivity can be obtained by using antigen or antibody-coated particles (e.g. latex) as reactants.

In flocculation methods, stepwise dilutions of one of the reactants is usually used whereas, in immunodiffusion (ID) methods, the dilution is obtained by diffusion in a gel medium concentration gradients of one or both of the reactants are obtained, thus creating zones in the gel medium where the ratio of the reactants favours precipitation. While flocculation methods are prescribed in tubes, immunodiffusion methods may be performed using different supports such as tubes, plates, slides, cells or chambers.

Where the immunoprecipitating system consists of one antigen combining with its corresponding antibody, the system is referred to as simple; when it involves related but not serologically identical reactants, the system is complex and where several serologically unrelated reactants are involved, the system is multiple.

In simple diffusion methods, a concentration gradient is established for only one of the reactants diffusing from an external source into the gel medium containing the corresponding reactant at a comparatively low concentration.

Single radial immunodiffusion (SRID) is a simple quantitative immunodiffusion technique. When the equilibrium between the external and the internal reactant has been established, the circular precipitation area originating from the site of the external reactant, is directly proportional to the amount of the antigen applied and inversely proportional to the concentration of the antibody in the gel.

In double diffusion methods, concentration gradients are established for both reactants. Both antigen and antibody diffuse from separate sites into an initially immunologically neutral gel.

Comparative double diffusion methods are used for qualitatively comparing various antigens versus a suitable antibody or vice versa. The comparison is based on the presence or absence of interaction between the precipitation patterns. Reactions of identity, non-identity or partial identity of antigens/antibodies can be distinguished.

### **Immunoelectrophoretic methods**

Immunoelectrophoresis (IE) is a qualitative technique combining two methods: Gel electrophoresis followed by immunodiffusion.

Crossed immunoelectrophoresis is a modification of the IE method. It is suitable both for qualitative and quantitative analysis. The first part of the procedure is an ordinary gel electrophoresis, after which a longitudinal gel strip, containing the separated fractions under determination, is cut out and transferred to another plate. The electrophoresis in the second direction is carried out perpendicular to the previous electrophoretic run in a gel containing a comparatively low concentration of antibodies corresponding to the antigens. For a given antibody concentration and gel thickness, the relationship between the area of the respective precipitation peaks and the amount of the corresponding antigen is linear.

Electroimmunoassay, often referred to as rocket immunoelectrophoresis is a rapid quantitative method for determining antigens with a charge differing from that of the antibodies or vice versa. The electrophoresis of the antigen under determination is carried out in a gel containing a comparatively lower concentration of the corresponding antibody. The test material and dilutions of a standard antigen used for calibration are introduced into different wells in the gel. During electrophoresis, migrating peak-shaped precipitation zones originating from the wells are developed. The front of the precipitate becomes stationary when the antigen is no longer in excess. For a given antibody concentration, the relationship between the distance travelled by the precipitate and the amount of antigen applied is linear.

Counter-immunoelectrophoresis is a rapid quantitative method allowing concentration gradients of external antigen and external antibody to be established in an electric field depending on the different charges. Dilutions of a standard for calibration and dilutions of the test material are introduced into a row of wells in a gel and a fixed amount of the corresponding reactant is introduced into an opposite row of wells. The titre of the test material may be determined as the highest dilution showing a precipitation line.

A number of modifications of crossed immunoelectrophoresis and electroimmunoassay methods exist.

Other techniques combine separation of antigens by molecular size and serological properties.

### *Visualisation and characterization of immunoprecipitation lines*

These may be performed by selective or non-selective stains, by fluorescence, by enzyme or isotope labelling or other relevant techniques. Selective staining methods are usually performed for characterization of non-protein substances in the precipitates.

In translucent gels such as agar or agarose, the precipitation line becomes clearly visible in the gel, provided that the concentration of each of the reactants is appropriate.

**Validation of the method***Validation criteria*

A quantitative immunochemical method is not valid unless:

- 1) The antibody or antigen does not significantly discriminate between the test and standard. For a labelled reactant, the corresponding reactant does not significantly discriminate between the labelled and unlabelled compound.
- 2) The method is not affected by the assay matrix, that is, any component of the test sample or its excipients, which can vary between samples. These may include high concentrations of other proteins, salts, preservatives or contaminating proteolytic activity.
- 3) The limit of quantitation is below the acceptance criteria stated in the individual monograph.
- 4) The precision of the assay is such that the variance of the results meets the requirements stated in the individual monographs.
- 5) The order to which the assay is performed does not give rise to systematic errors.

*Validation methods*

In order to verify these criteria, the validation design includes the following elements:

- 1) The assay is performed at least in triplicate.
- 2) The assay includes at least 3 different dilutions of the standard preparation and 3 different dilutions of sample preparations of presumed activity similar to the standard preparation.
- 3) The assay layout is randomized.
- 4) If the test sample is presented in serum or formulated with other components, the standard is likewise prepared.
- 5) The test includes the measurement of non-specific binding of the labelled reactant.
- 6) For displacement immunoassay:
  - a) maximum binding (zero displacement) is determined;
  - b) dilutions cover the complete response range from values close to non-specific binding to maximum binding, preferably for both standard and test preparations.

**Statistical calculation**

To analyse the result, response curves for test and standard may be analysed by the methods stated under Statistical Analysis of Results (5.7).

Significant non-parallelism indicates that the antibody or antigen discriminates between test and standard, and the results are not valid.

In displacement immunoassays, the value for non-specific binding and maximum displacement at high test or standard concentration must not be significantly different. Differences may indicate effects due to the matrix, either inhibition of binding or degradation of tracer.

**2.2.15. Host-cell and Vector-derived DNA**

Residual DNA is detected by hybridization analysis, using suitably sensitive, sequence independent analytical techniques or other suitably sensitive analytical techniques.

*Hybridisation analysis*

DNA in the test sample is denatured to give single-stranded DNA, immobilized on a *nitrocellulose* or other suitable filter and hybridized with labelled DNA prepared from the host-vector manufacturing system (DNA probes). Although a wide variety of experimental approaches are available, hybridization methods for measurement of host-vector DNA meet the following criteria:

- *DNA probes.* Vero cells should be grown under the same conditions as those used in the vaccine manufacturing process and chromosomal DNA should be purified and used as probes. The purified DNA should be digested with appropriate restriction enzyme (for example, EcoRI, BamHI etc.), deproteinized and purified. The concentration of DNA should be measured spectroscopically and the DNA should be stored at appropriate storage condition. Such DNA preparations should be labelled by radioactive or non-radioactive methods and used as probes in dot blot or slot blot analysis. The labelling technique should generate high specific activity probes so that 10 picograms of DNA can be detected when used in dot blot/slot blot experiments.
- *Standardization and hybridization conditions.* Each batch of Vero cell DNA prepared as described above should be calibrated and used as standards. Different amounts of denatured Vero cell DNA (0, 10, 25, 50, 100, 250, 500, 750 and 1000 picograms) should be loaded on a nitrocellulose/nylon filter along with DNA purified from test samples (preferable in duplicate). Filters should be hybridized with labelled vero cell DNA probes. The stringency of hybridization conditions should be such as to ensure specific hybridization between the probes and standard DNA preparations.
- *Calibration and standardization.* Quantitative data are obtained by comparison with responses obtained using standard preparations. Chromosomal DNA probes and



vector DNA probes are used with chromosomal DNA and vector DNA standards, respectively. Standard preparations are calibrated by spectroscopic measurements and stored in a state suitable for use over an extended period of time.

- Hybridisation conditions. The stringency of hybridization conditions is such as to ensure specific hybridization between probes and standard DNA preparations and the drug substance must not interfere with hybridization at the concentrations used.

#### *Sequence-independent techniques*

Suitable procedures include detection of sulphonated cytosine residues in single-stranded DNA (where DNA is immobilized on a filter and cytosines are derivatised *in situ*, before detection and quantitation using an antibody directed against the sulphonated group); detection of single-stranded DNA using a fragment of single-stranded DNA bound to a protein and an antibody of this protein. Neither procedure requires the use of specific heat or vector DNA as an assay standard. However, the method used must be validated to ensure parallelism with the DNA standard used, linearity of response and non-interference of either the drug substance or excipients of the formulation at the dilutions used in the assay.

Any other method or technique shall be validated and approved by the national regulatory authority.

### **2.2.16. Limes flocculationis (Lf)**

The Limes flocculationis (Lf) of diphtheria toxin, diphtheria toxoid or diphtheria vaccine or tetanus vaccine is determined by incubating together the preparation under examination and

the Standard preparation of diphtheria antitoxin or tetanus antitoxin for flocculation test in appropriate concentrations. When the concentration of toxin, or toxoid, is kept constant and the concentration of the antitoxin varied in mixtures of constant volume, the mixture flocculating first is that which contains the most nearly equivalent quantities of toxin, or toxoid and antitoxin.

#### *Reference preparation*

The Reference preparation is freeze-dried purified hyperimmune horse serum of the relevant antitoxin or other suitable preparation the activity of which has been determined in relation to the International reference preparation.

#### **Suggested method**

Carry out preliminary tests to determine the range of concentrations to be used. To each of a series of small tubes containing equal volumes of graded concentrations of the Reference preparation add a constant volume of a solution of the preparation under examination. In successive tubes the antitoxin concentration should increase by amounts not greater than one-tenth of the concentration in the middle of the range of concentrations. Choose a range in such a manner that the optimum flocculating mixture will occur in the middle of the range. Heat the tubes in a water-bath at 45° to 50° with half the fluid column immersed to obtain convection currents. Continue heating and observe the tubes until the most rapidly flocculating mixture has been determined. The number of Lf in the quantity of the preparation under examination is numerically equal to the number of Lf equivalents of antitoxin in this mixture. The error of a single determination has been estimated to be not more than 5.0 per cent.



## 2.3. CHEMICAL METHODS

<b>Identification</b>	....
2.3.1. Identification Reactions of Ions and Functional Groups	....
2.3.2. Identification of Barbiturates	....
2.3.3. Identification of Phenothiazines	....
2.3.4. Related Substances in Barbiturates	....
2.3.5. Related Substances in Phenothiazines	....
2.3.6. Related Foreign Steroids	....
2.3.7. Related Substances in Sulphonamides	....
<b>Limit Tests</b>	....
2.3.8. Aluminium	....
2.3.9. Aluminium in Adsorbed Vaccines	....
2.3.10. Arsenic	....
2.3.11. Calcium in Adsorbed Vaccines	....
2.3.12. Chlorides	....
2.3.13. Heavy metals	....
2.3.14. Iron	....
2.3.15. Lead	....
2.3.16. Potassium	....
2.3.17. Sulphates	....
2.3.18. Sulphated Ash	....
2.3.19. Total Ash	....
2.3.20. Free Formaldehyde	....
2.3.21. <i>N-N</i> -Dimethylaniline	....
<b>Assays</b>	....
2.3.22. Acetyl Value	....
2.3.23. Acid Value	....
2.3.24. Cineole	....
2.3.25. Esters	....
2.3.26. Ester Value	....
2.3.27. Hydroxyl Value	....

---

2.3.28. Iodine value	....
2.3.29. Methoxyl	....
2.3.30. Nitrogen	....
2.3.31. Nitrite Titration	....
2.3.32. Assay of Nitrous Oxide	....
2.3.33. Assay of Oxygen	....
2.3.34. Oxygen-Flask Method	....
2.3.35. Peroxide Value	....
2.3.36. Phenol in Vaccines and Antisera	....
2.3.37. Saponification Value	....
2.3.38. Assay of Steroids	....
2.3.39. Unsaponifiable Matter	....
2.3.40. Sulphur Dioxide	....
2.3.41. Assay of Vitamin A	....
2.3.42. Assay of Vitamin D	....
2.3.43. Water	....
2.3.44. Zinc	....
2.3.45. Ethanol	....
2.3.46. Assay of Insulins	....
2.3.47. Peptide Mapping	....
2.3.48. Thiomersal	....
2.3.49 Protein	....

## Identification

### 2.3.1. General Identification Reactions

The following tests may be used for the identification of chemicals referred to in the Pharmacopoeia. They are not intended to be applicable to mixtures of substances unless so specified.

#### Acetates

A. Heat the substance under examination with an equal quantity of *oxalic acid*; acidic vapours with the characteristic odour of acetic acid are liberated.

B. Warm 1 g of the substance under examination with 1 ml of *sulphuric acid* and 3 ml of *ethanol (95 per cent)*; ethyl acetate, recognisable by its odour, is evolved.

C. Dissolve about 30 mg of the substance under examination in 3 ml of *water* or use 3 ml of the prescribed solution, add successively 0.25 ml of *lanthanum nitrate solution*, 0.1 ml of *0.1 M iodine* and 0.05 ml of *dilute ammonia solution*. Heat carefully to boiling, within a few minutes a blue precipitate or a dark blue colour is produced.

#### Acetyl Groups

In a test-tube (about 180 mm x 18 mm) place 10 to 20 mg or the prescribed quantity of the substance under examination and add 0.15 ml of *phosphoric acid*. Close the tube with a stopper through which passes a small test-tube (about 100 mm x 10mm) containing *water* to act as a condenser. On the outside of the smaller tube, hang a drop of *lanthanum nitrate solution*.

Except for substances hydrolysable only with difficulty, place the apparatus in a water-bath for 5 minutes and remove the smaller tube. Mix the drop with 0.05 ml of *0.01 M iodine* on a porcelain tile or glass slide and then add one drop of *2M ammonia* at the edge of the mixed drop; after 1 or 2 minutes a blue colour is produced at the junction of the two drops and the colour intensifies and persists for a short time.

For substances hydrolysable only with difficulty, heat the mixture slowly to boiling point over an open flame instead of using a water-bath.

#### Alkaloids

Dissolve a few mg or the prescribed quantity of the substance under examination in 5 ml of *water*, add *dilute hydrochloric acid* until the solution has an acid reaction and then add 1 ml of *potassium iodobismuthate solution*; an orange or orange-red precipitate is formed immediately

#### Aluminium Salts

A. Dissolve about 20 mg of the substance under examination in 2 ml of *water* or use 2 ml of the prescribed solution, add

about 0.5 ml of *2 M hydrochloric acid* and about 0.5 ml of *thioacetamide reagent*; no precipitate is produced. Add dropwise *2M sodium hydroxide*; a gelatinous white precipitate is produced which redissolves on addition of further *2M sodium hydroxide*. Gradually add *ammonium chloride solution*; the gelatinous white precipitate reappears.

B. Dissolve about 20 mg of the substance under examination in 5 ml of *water* or use 5 ml of the prescribed solution, add 5 drops of *ammonium acetate solution* and 5 drops of a 0.1 per cent w/v solution of *mordant blue 3*; and intense purple colour is produced.

C. To a solution of the substance under examination in *water* add *dilute ammonia solution* until a faint precipitate is produced and then add 0.25 ml of a freshly prepared 0.05 per cent w/v solution of *quinalizarin* in a 1 per cent w/v solution of *sodium hydroxide*. Heat to boiling, cool, and acidify with an excess of *acetic acid*, a reddish violet colour is produced.

#### Amines, Primary Aromatic

Acidify the prescribed solution with *2 M hydrochloric acid* or dissolve 0.1 g of the substance under examination in 2 ml of *2M hydrochloric acid* and add 0.2 ml of *sodium nitrite solution*. After 1 or 2 minutes add the solution to 1ml of *2-naphthol solution*; an intense orange or red colour and, usually, a precipitate of the same colour is produced.

#### Ammonium salts

A. Heat a few mg of the substance under examination with *sodium hydroxide solution*; ammonia is evolved, which is recognisable by its odour and by its action on moist *red litmus paper*, which turns blue.

B. To the prescribed solution add 0.2 g of *light magnesium oxide*. Pass a current of air through the mixture and direct the gas that is evolved to just beneath the surface of a mixture of 1 ml of *0.1M hydrochloric acid* and 0.05 ml of *methyl red solution*; the colour of the solution changes to yellow. On addition of 1 ml of a freshly prepared 10 per cent w/v solution of *sodium cobaltinitrite*, a yellow precipitate is produced.

#### Antimony Compounds

Dissolve with gently heating about 10 mg of the substance under examination in a solution of 0.5 g of *sodium potassium tartrate* in 10 ml of *water* and allow to cool. To 2 ml of this solution or to 2 ml of the prescribed solution add *sodium sulphide solution* dropwise; a reddish orange precipitate which dissolves on adding *dilute sodium hydroxide solution* is produced.

#### Arsenic Compounds

Heat 5 ml of the prescribed solution on a water-bath with an equal volume of *hypophosphorus reagent*; a brown precipitate is formed.

**Barbiturates**

Dissolve 5 mg of the substance under examination in 3 ml of a hot 0.2 per cent w/v solution of *cobaltous acetate* in *methanol*, add 5 mg of finely powdered *sodium tetraborate* and boil; a blue-violet colour is produced.

**Barbiturates, Non-nitrogen Substituted**

Dissolve 5 mg of the substance under examination in 3 ml of *methanol*, add 0.1 ml of a solution containing 10 per cent w/v of *cobaltous nitrate* and 10 per cent w/v of *calcium chloride*, mix and add, with shaking, 0.1 ml of *dilute sodium hydroxide solution*; a violet-blue colour and a precipitate are produced.

**Barium Salts**

A. Barium salts impart a yellowish green colour to a non-luminous flame which appears blue when viewed through a green glass.

B. Dissolve 20 mg of the substance under examination in 5 ml of *dilute hydrochloric acid* and add 2 ml of *dilute sulphuric acid*; a white precipitate, insoluble in *nitric acid*, is formed.

**Benzoates**

A. To 1 ml of a 10 per cent w/v neutral solution of the substance under examination add 0.5 ml of *ferric chloride test solution*; a dull yellow precipitate, soluble in *ether*, is formed.

B. Moisten 0.2 g of the substance under examination with 0.2 to 0.3 ml of *sulphuric acid* and gently warm the bottom of the tube; a white sublimate is deposited on the inner walls of the tube and no charring occurs.

C. Dissolve 0.5 g of the substance under examination in 10 ml of *water* or use 10 ml of the prescribed solution and add 0.5 ml of *hydrochloric acid*; the precipitate obtained, after crystallisation from *water* and drying at a pressure of 2 kPa, melts at about 122° (2.4.21).

**Bicarbonates**

A. Solutions, when boiled, liberate carbon dioxide.

B. Treat a solution of the substance under examination with a solution of *magnesium sulphate*; no precipitate is formed (distinction from carbonates); boil, a white precipitate is formed.

C. Introduce into a test-tube 0.1 g of the substance under examination suspended in 2 ml of *water* or in 2 ml of the prescribed solution. Add 2 ml of 2 M *acetic acid*, close the tube immediately using a stopper fitted with a glass tube bent at two right-angles, heat gently and collect the gas in 5 ml of *barium hydroxide solution*; a white precipitate forms that dissolves on addition of an excess of *dilute hydrochloric acid*.

**Bismuth Compounds**

A. To 0.5 g of the substance under examination add 10 ml of 2 M *hydrochloric acid* or use 10 ml of the prescribed solution.

Heat to boiling for 1 minute, cool and filter, if necessary. To 1 ml of the filtrate add 20 ml of *water*; a white or slightly yellow precipitate is formed which on addition of 0.05 to 0.1 ml of *sodium sulphide solution* turns brown.

B. To about 50 mg of the substance under examination add 10 ml of 2 M *nitric acid* or use 10 ml of the prescribed solution. Heat to boiling for 1 minute, allow to cool and filter, if necessary. To 5 ml of the filtrate add 2 ml of a 10 per cent w/v solution of *thiourea*; an orange-yellow colour or an orange precipitate is produced. Add 4 ml of a 2.5 per cent w/v solution of *sodium fluoride*, the solution is not decolorised within 30 minutes.

**Bromides**

A. Dissolve a quantity of the substance under examination equivalent to about 3 mg of bromide ion in 2 ml of *water* or use 2 ml of the prescribed solution. Acidify with 2 M *nitric acid*, add 1 ml of 0.1 M *silver nitrate*, shake and allow to stand; a curdy, pale yellow precipitate forms. Centrifuge and wash the precipitate rapidly with three quantities, each of 1 ml, of *water* in subdued light. Suspend the precipitate in 2 ml of *water* and add 1.5 ml of 10 M *ammonia*; the precipitate dissolves with difficulty.

B. Dissolve about 10 mg of the substance under examination in 2 ml of *water* and 1 ml of *chlorine solution*; bromine is evolved, which is soluble in 2 or 3 drops of *chloroform*, forming a reddish solution. To the aqueous solution containing the liberated bromine add *phenol solution*; a white precipitate is produced.

*NOTE* — In testing for bromides in the presence of iodides, all iodine must first be removed by boiling the aqueous solution with an excess of lead dioxide.

**Calcium Salts**

A. Dissolve 20 mg of the substance under examination in 5 ml of 5M *acetic acid* or add 1 ml of *glacial acetic acid* to 5 ml of the prescribed solution. Add 0.5 ml of *potassium ferrocyanide solution*, the solution remains clear. Add about 50 mg of *ammonium chloride*; a white, crystalline precipitate is formed.

B. To 5 ml of a 0.4 per cent w/v solution of the substance under examination add 0.2 ml of a 2 per cent w/v solution of *ammonium oxalate*; a white precipitate is obtained that is only sparingly soluble in *dilute acetic acid* but is soluble in *hydrochloric acid*.

C. Dissolve 20 mg of the substance under examination in the minimum quantity of *dilute hydrochloric acid* and neutralise with *dilute sodium hydroxide solution* or use 5 ml of the prescribed solution. Add 5 ml of *ammonium carbonate solution*; a white precipitate is formed which, after boiling and cooling the mixture, is only sparingly soluble in *ammonium chloride solution*.

**Carbonates**

A. Suspend 0.1 g of the substance under examination in a test-tube in 2 ml of *water* or use 2 ml of the prescribed solution. Add 2 ml of *2M acetic acid*, close the tube immediately using a stopper fitted with a glass tube bent at two right-angles, heat gently and collect the gas in 5 ml of *0.1 M barium hydroxide*, a white precipitate is formed that dissolves on addition of an excess of *dilute hydrochloric acid*.

B. Treat a solution of the substance under examination with a solution of *magnesium sulphate*; a white precipitate is formed (distinction from bicarbonates).

**Chlorides**

A. Dissolve a quantity of the substance under examination equivalent to about 2 mg of chloride ion in 2 ml of *water* or use 2 ml of the prescribed solution. Acidify with *dilute nitric acid*, add 0.5 ml of *silver nitrate solution*, shake and allow to stand; a curdy white precipitate is formed, which is insoluble in *nitric acid* but soluble, after being well washed with *water*, in *dilute ammonia solution*, from which it is reprecipitated by the addition of *dilute nitric acid*.

B. Introduce into a test-tube a quantity of the substance under examination equivalent to about 10 mg of chloride ion, add 0.2 g of *potassium dichromate* and 1 ml of *sulphuric acid*. Place a filter-paper strip moistened with 0.1 ml of *diphenylcarbazide solution* over the mouth of the test-tube; the paper turns violet-red. (Do not bring the moistened paper into contact with the potassium dichromate solution).

**Citrates**

A. To a neutral solution of the substance under examination add a solution of *calcium chloride*; no precipitate is produced. Boil the solution; a white precipitate soluble in *6M acetic acid* is produced.

B. Dissolve a quantity of the substance under examination containing about 50 mg of citric acid in 5 ml of *water* or use 5 ml of the prescribed solution. Add 0.5 ml of *sulphuric acid* and 3 ml of *potassium permanganate solution*. Warm until the colour of the permanganate is discharged and add 0.5 ml of a 10 per cent w/v solution of *sodium nitroprusside* in *1 M sulphuric acid* and 4 g of *sulphamic acid*. Make alkaline with *strong ammonia solution*, added dropwise until all the sulphamic acid has dissolved. On addition of an excess of *strong ammonia solution*, a violet colour, which turns violet-blue, is produced.

**Esters**

To about 30 mg. of the substance under examination or to the prescribed quantity add 0.5 ml of a 7 per cent w/v solution of *hydroxylamine hydrochloride* in *methanol* and 0.5 ml of a 10 per cent w/v solution of *potassium hydroxide* in *ethanol* (95

per cent). Heat to boiling, cool, acidify with *2M hydrochloric acid* and add 0.2 ml of a 1 per cent w/v solution of *ferric chloride*; a bluish-red or red colour is produced.

**Ferric salts**

A. Dissolve a quantity of the substance under examination containing about 10 mg of iron in 1 ml of *water* or use 1 ml of the prescribed solution. Add 1 ml of *potassium ferrocyanide solution*; an intense blue precipitate, insoluble in *dilute hydrochloric acid*, is produced.

B. To 3 ml of solution containing about 0.1 mg of iron or to 3 ml of the prescribed solution add 1 ml of *2M hydrochloric acid* and 1 ml of *ammonium thiocyanate solution*; the solution becomes blood-red in colour. Take two portions, each of 1 ml, of the mixture. To one portion add 5 ml of *ether*, shake and allow to stand; the ether layer is pink. To the other portion add 3 ml of *0.2M mercuric chloride*; the red colour disappears.

C. To 2 ml of solution containing about 0.1 mg of iron or to 3 ml of the prescribed solution add *acetic acid* until the solution is strongly acidic. Add 2 ml of a 0.2 per cent w/v solution of *8-hydroxy-7-iodoquinoline-5-sulphonic acid*; a stable green colour is produced.

**Ferrous Salts**

A. Dissolve a quantity of the substance under examination containing about 10 mg of iron in 2 ml of *water* or use 2 ml of the prescribed solution. Add 2 ml of *dilute sulphuric acid* and 1 ml of a 0.1 per cent w/v solution of *1,10-phenanthroline*; an intense red colour which is discharged by addition of a slight excess of *0.1 M ceric ammonium sulphate* is produced.

B. To 1 ml of a solution containing not less than 1 mg of iron or to 1 ml of the prescribed solution add 1 ml of *potassium ferricyanide solution*; a dark blue precipitate is formed that is insoluble in *dilute hydrochloric acid* and is decomposed by *sodium hydroxide solution*.

C. To 1 ml of a solution containing not less than 1 mg of iron or to 1 ml of the prescribed solution add 1 ml of *potassium ferrocyanide solution*; a white precipitate is formed which rapidly becomes blue and is insoluble in *dilute hydrochloric acid*.

**Iodides**

A. Dissolve a quantity of the substance under examination containing about 4 mg of iodide ion in 2 ml of *water* or use 2 ml of the prescribed solution. Acidify with *dilute nitric acid* and add 0.5 ml of *silver nitrate solution*. Shake and allow to stand; a curdy, pale yellow precipitate is formed. Centrifuge and wash the precipitate rapidly with three quantities, each of 1 ml, of *water*, in subdued light. Suspend the precipitate in 2 ml of *water* and add 1.5 ml of *10 M ammonia*; the precipitate does not dissolve.



B. To 0.2 ml of solution of the substance under examination containing about 5 mg of iodide ion per ml or to 0.2 ml of the prescribed solution add 0.5 ml of 1 M sulphuric acid, 0.15 ml of potassium dichromate solution, 2 ml of water and 2 ml of chloroform shake for few seconds and allow to stand; the chloroform layer is violet or violet-red.

C. To 1 ml of a solution of the substance under examination containing about 5 mg of iodide ion add 0.5 ml of mercuric chloride solution; a dark red precipitate is formed which is slightly soluble in an excess of this reagent and very soluble in an excess of potassium iodide solution.

#### Lactates

To 5 ml of a solution of the substance under examination containing about 5 mg of lactic acid or to 5 ml of the prescribed solution add 1 ml of bromine water and 0.5 ml of 1M sulphuric acid. Heat on a water-bath, stirring occasionally with a glass rod until the colour is discharged. Add 4 g of ammonium sulphate, mix and add dropwise, without mixing, 0.2 ml of a 10 per cent w/v solution of sodium nitroprusside in 1M sulphuric acid. Without mixing, add 1 ml of strong ammonia solution and allow to stand for 30 minutes; a dark green ring appears at the interface of the two liquids.

#### Lead Compounds

A. Dissolve 0.1 g of the substance under examination in 1 ml of dilute acetic acid or use 1 ml of the prescribed solution. Add 2 ml of potassium chromate solution; a yellow precipitate insoluble in 2 ml of 10M sodium hydroxide is produced.

B. Dissolve 50 mg of the substance under examination in 1 ml of dilute acetic acid or use 1 ml of the prescribed solution. Add 10 ml of water and 0.2 ml of 1 M potassium iodide; a yellow precipitate is formed. Heat to boiling for 1 or 2 minutes and allow to cool; the precipitate is reformed as glistening, yellow plates.

#### Magnesium Salts

A. Dissolve about 15 mg of the substance under examination in 2 ml of water or use 2 ml of the prescribed solution. Add 1 ml of dilute ammonia solution; a white precipitate forms that is redissolved by adding 1 ml of 2 M ammonium chloride. Add 1 ml of 0.25 M disodium hydrogen phosphate; a white crystalline precipitate is produced.

B. To 0.5 ml of a neutral or slightly acid solution of the substance under examination add 0.2 ml of a 0.1 per cent w/v solution of titan yellow and 0.5 ml of 0.1 M sodium hydroxide; a bright red turbidity develops which gradually settles to give a bright red precipitate.

#### Mercury Compounds

A. Place 0.05 to 0.1 ml of a solution of the substance under examination on a well-scraped copper foil; a dark grey stain,

which becomes shiny on rubbing, is produced. Heat the dried copper foil in a test-tube; the spot disappears.

B. To a solution of the substance under examination add carefully potassium iodide solution; a red precipitate is produced which is soluble in an excess of the reagent (mercuric compounds) or a yellow precipitate is produced which may become green on standing (mercurous compounds).

C. To the prescribed solution add 2M sodium hydroxide until strongly alkaline; a dense, yellow precipitate is produced (mercuric compounds).

D. To a solution of the substance under examination add 6 M hydrochloric acid; a white precipitate is produced which is blackened by adding dilute ammonia solution (mercurous compounds).

#### Nitrates

A. Dissolve 15 mg of the substance under examination in 0.5 ml of water, add cautiously 1 ml of sulphuric acid, mix and cool. Incline the tube and carefully add, without mixing, 0.5 ml of ferrous sulphate solution; a brown colour is produced at the interface of the two liquids.

B. To a mixture of 0.1 ml of nitrobenzene and 0.2 ml of sulphuric acid add a quantity of the powdered substance under examination equivalent to about 1 mg of nitrate ion or the prescribed quantity. Allow to stand for 5 minutes and cool in ice whilst adding slowly with stirring 5 ml of water and then 5 ml of sodium hydroxide solution. Add 5 ml of acetone, shake and allow to stand; the upper layer shows an intense violet colour.

#### Penicillins

To 2 mg of the substance under examination add 2 mg of chromotropic acid sodium salt and 2 ml sulphuric acid and immerse in an oil-bath at 150°; the solution, when shaken and examined every 30 seconds, exhibits the colours stated in Table 1.

#### Penicillins and Cephalosporins

Carry out Tests A and B unless otherwise stated in the monograph.

A. Place 2 mg of the substance under examination in a test-tube (about 15 cm × 15 mm), moisten with 0.05 ml of water and add 2 ml of sulphuric acid (95 per cent). Mix the contents of the tube by swirling and examine the colour of the solution. Immerse the test-tube in a water-bath for 1 minute and examine the colour again. The solution exhibits the colours stated in columns 2 and 3 of Table 2.

B. Carry out the procedure described in Test A using 2 ml of a mixture of 2 ml of formaldehyde solution and 100 ml of sulphuric acid (95 per cent) in place of the sulphuric acid (96 per cent w/w). The solution exhibit the colours stated in columns 4 and 5 of Table 2.

Table 1

Time (min)	Ampicillin, Ampicillin Sodium, Ampicillin Trihydrate	Benzathine Penicillin, Benzylpenicillin Potassium/ Sodium	Carbenicillin Sodium	Cloxacillin Sodium	Phenoxyethylpenicillin Potassium
0	Colourless	Yellow	Colourless	Colourless	Colourless
0.5	Colourless	Yellow	Light brown	Pale yellow	Colourless
1	Colourless	Yellow	Yellowish brown	Greenish yellow	Colourless
1.5	Colourless	Orange yellow	Greenish brown	Yellowish green	Pale pink
2	Purple	Orange yellow	Greenish brown	Green	Purple
2.5	Deep purple	Orange yellow	Brown	Greenish purple	Purple
3	Violet	Pale orange	Dark brown	Purple	Bluish violet
3.5	Violet	Orange or may char	Dark brown	Purple	Dark blue
4	Charred	–	–	–	–

Table 2

Substance	Sulphuric acid (95 per cent)	Sulphuric acid (95 per cent) after 1 minute at 100°	Formaldehyde solution and sulphuric acid (95 per cent)	Formaldehyde solution and sulphuric acid (95 per cent) after 1 minute at 100°
(1)	(2)	(3)	(4)	(5)
Amoxicillin Trihydrate			Almost colourless	Dark yellow
Ampicillin			Almost colourless	Dark yellow
Ampicillin Sodium			Almost colourless	Dark yellow
Ampicillin Trihydrate			Almost colourless	Dark yellow
Benzathine penicillin			Almost colourless	Reddish brown
Benzylpenicillin Potassium				Reddish brown
Benzylpenicillin Sodium			Almost colourless	Reddish brown
Carbenicillin Sodium			Almost colourless	Yellowish brown
Cephalexin	Almost colourless	Pale yellow	Pale yellow	Yellow
Cefadroxil			Yellow	Orange
Cephaloridine	Pale yellow	Almost colourless	Red	Brownish red
Cloxacillin Sodium			Slightly greenish yellow	Yellow
Phenoxyethyl penicillin Potassium			Reddish brown	Dark Reddish brown
Procaine Penicillin	Almost colourless	Almost colourless	Almost colourless	Reddish Brown

**Phosphates (Orthophosphates)**

A. To 5 ml of the prescribed solution, neutralised to pH 7.0, add 5 ml of *silver nitrate solution*; a light yellow precipitate forms, the colour of which is not changed by boiling and which is readily soluble in *10 M ammonia* and in *dilute nitric acid*.

B. Mix 1 ml of the prescribed solution with 1 ml of *ammoniacal magnesium sulphate solution*; a white crystalline precipitate is formed.

C. To 2 ml of the prescribed solution and 2 ml of *dilute nitric acid* and 4 ml of *ammonium molybdate solution* and warm the solution; a bright yellow precipitate is formed.

### Potassium Salts

A. Dissolve about 50 mg of the substance under examination in 1 ml of *water* or use 1 ml of the prescribed solution. Add 1 ml of *dilute acetic acid* and 1 ml of a freshly prepared 10 per cent w/v solution of *sodium cobaltinitrite*; a yellow or orange-yellow precipitate is produced immediately.

B. Dissolve 0.1 g of the substance under examination in 2 ml of *water* or use 2 ml of the prescribed solution. Heat the solution with 1 ml of *sodium carbonate solution*; no precipitate is formed. Add 0.05 ml of *sodium sulphide solution*; no precipitate is formed. Cool in ice, add 2 ml of a 15 per cent w/v solution of *tartaric acid* and allow to stand; a white, crystalline precipitate is produced.

C. Ignite a few mg of the substance under examination, cool and dissolve in the minimum quantity of *water*. To this solution add 1 ml of *platinic chloride solution* in the presence of 1 ml of *hydrochloric acid*; a yellow, crystalline precipitate is produced which on ignition leaves a residue of potassium chloride and platinum.

### Salicylates

A. To 1 ml of a 10 per cent w/v neutral solution add 0.5 ml of *ferric chloride test solution*; a violet colour is produced which persists after the addition of 0.1 ml of *dilute acetic acid*.

B. Dissolve 0.5 g of the substance under examination in 10 ml of *water* or use 10 ml of the prescribed solution. Add 0.5 ml of *hydrochloric acid*; the precipitate obtained after recrystallisation from hot *water* and drying at a pressure of 2 kPa melts at about 159° (2.4.21).

C. Dissolve 0.5 g of the substance under examination in 10 ml of *water* or use 10 ml of the prescribed solution. Add 2 ml of *bromine solution*; a cream-coloured precipitate is formed.

### Silicates

In a lead or platinum crucible mix by means of a copper wire to obtain a thin slurry the prescribed quantity of the substance under examination with 10 mg of *sodium fluoride* and a few drops of *sulphuric acid*. Cover the crucible with a thin transparent plate of plastic under which a drop of *water* is suspended and warm gently; within a short time a white ring is formed around the drop of water.

### Silver Compounds

Dissolve 10 mg of the substance under examination in 10 ml of *water* or use 10 ml of the prescribed solution. Add 0.3 ml of *dilute hydrochloric acid*; a curdy white precipitate, soluble in *dilute ammonia solution*, is produced. Add *potassium iodide solution*; a yellow precipitate, soluble in *nitric acid*, is produced.

### Sodium Salts

A. Dissolve 0.1 g of the substance under examination in 2 ml of *water* or use 2 ml of the prescribed solution. Add 2 ml of a 15 per cent w/v solution of *potassium carbonate* and heat to boiling; no precipitate is produced. Add 4 ml of a freshly prepared *potassium antimonate solution* and heat to boiling. Allow to cool in ice and if necessary scratch the inside of the test-tube with a glass rod; a dense, white precipitate is formed.

B. Acidify a solution of the substance under examination with *IM acetic acid* and add a large excess of *magnesium uranyl acetate solution*; a yellow, crystalline precipitate is formed.

### Sulphates

A. Dissolve about 50 mg of the substance under examination in 5 ml of *water* or use 5 ml of the prescribed solution. Add 1 ml of *dilute hydrochloric acid* and 1 ml of *barium chloride solution*; a white precipitate is formed.

B. Add 0.1 ml of *iodine solution* to the suspension obtained in test A; the suspension remains yellow (distinction from sulphites and dithionites) but is decolorised by adding, dropwise, *stannous chloride solution* (distinction from iodates). Boil the mixture; no coloured precipitate is formed (distinction from selenates and tungstates).

C. Dissolve about 50 mg of the substance under examination in 5 ml of *water* or use 5 ml of the prescribed solution. Add 2 ml of *lead acetate solution*; a white precipitate, soluble in *ammonium acetate solution* and in *sodium hydroxide solution*, is produced.

### Sulphur in Organic Compounds

A. Burn about 20 mg of the substance under examination by the oxygen-flask method (2.3.34), using 15 ml of *water* and 2 ml of *hydrogen peroxide solution (10 vol)* as the absorbing liquid. When combustion is complete, boil the solution gently for 10 minutes, adding *water* if necessary, and cool. The resulting solution gives the reactions of sulphates.

B. To about 50 mg of the substance under examination add 0.25 g of *zinc metal and sodium carbonate reagent*, mix and transfer to a small, thin-walled test-tube of hard glass and cover with a layer of the reagent. Carefully heat the tube to red heat, starting at the upper end and heating towards the bottom, and then drop the tube immediately into about 20 ml of *water*. Filter and acidify the filtrate with *hydrochloric acid*; fumes which stain *lead acetate paper* brown or black are evolved.

### Tartrates

A. Warm the substance under examination with *sulphuric acid*; charring occurs and carbon monoxide, which burns with a blue flame when ignited, is evolved.

B. Dissolve about 20 mg of the substance under examination in 5 ml of *water* or use 5 ml of the prescribed solution. Add 0.05 ml of a 1 per cent w/v solution of *ferrous sulphate* and 0.05 ml of *hydrogen peroxide solution (10 vol)*; a transient yellow colour is produced. After the colour has disappeared add 2M *sodium hydroxide* dropwise; an intense blue colour is produced.

C. Heat 0.1 ml of solution containing about 2 mg of tartaric acid or 0.1 ml of prescribed solution on a water-bath for 5 to 10 minutes with 0.1 ml of a 10 per cent w/v solution of *potassium bromide*, 0.1 ml of 2 per cent w/v solution of *resorcinol* and 3 ml of *sulphuric acid*; a dark blue colour that changes to red when the solution is cooled and poured into *water* is produced.

#### Thiosulphates

A. Dissolve 0.1 g of the substance under examination in 5 ml of *water* and add 2 ml of *hydrochloric acid*; a white precipitate is formed which soon turns yellow and sulphur dioxide, recognisable by its odour, is evolved.

B. Dissolve 0.1 g of the substance under examination in 5 ml of *water* and add 2 ml of *ferric chloride test solution*; a dark violet colour which quickly disappears is produced.

C. Solutions of thiosulphates decolorise *iodine solution*; the decolorised solutions do not give the reactions of sulphates.

D. Solutions of thiosulphates decolorise *bromine solution*; the decolorised solutions give the reactions of sulphates.

#### Xanthines

Mix a few mg of the substance under examination or the prescribed quantity with 0.1 ml of *hydrogen peroxide solution (100 vol)* and 0.3 ml of 2M *hydrochloric acid*, heat to dryness on a water-bath until a yellowish red residue is produced and add 0.1 ml of 2M *ammonia*; the colour of the residue changes to reddish violet.

#### Zinc Salts

A. Dissolve 0.1 g of the substance under examination in 5 ml of *water* or use 5 ml of the prescribed solution. Add 0.2 ml of *sodium hydroxide solution*; a white precipitate is produced. Add a further 2 ml of *sodium hydroxide solution*; the precipitate dissolves. Add 10 ml of *ammonium chloride solution*; the solution remains clear. Add 0.1 ml of *sodium sulphide solution*; a flocculent, white precipitate is produced.

B. Dissolve 0.1 g of the substance under examination in 5 ml of *water* or use 5 ml of the prescribed solution. Acidify with *dilute sulphuric acid* and add one drop of a 0.1 per cent w/v solution of *cupric sulphate* and 2 ml of *ammonium mercurithiocyanate solution*; a violet precipitate is formed.

C. Dissolve 0.1 g of the substance under examination in 5 ml of *water* or use 5 ml of the prescribed solution. Add 2 ml of

*potassium ferrocyanide solution*; a white precipitate, insoluble in *dilute hydrochloric acid*, is produced.

#### 2.3.2. Identification of Barbiturates

Determine by thin-layer chromatography (2.4.17), coating the plate with *silica gel GF254*.

*Mobile phase.* Shake a mixture of 80 volumes of *chloroform*, 15 volumes of *ethanol (95 per cent)* and 5 volumes of *strong ammonia solution*. Use the lower layer.

*Test solution.* A 0.1 per cent w/v solution of the substance under examination in *ethanol (95 per cent)*.

*Reference solution.* A 0.1 per cent w/v solution of the corresponding *Reference Substance* in *ethanol (95 per cent)*.

Apply to the plate 10 µl of each solution. Allow the mobile phase to rise 18 cm. Remove the plate, allow to dry and examine in ultraviolet light at 254 nm. The principal spot in the chromatogram obtained with the test solution corresponds to that in the chromatogram obtained with the reference solution.

#### 2.3.3. Identification of Phenothiazines

Determine protected from light by thin-layer chromatography (2.4.17), coating the plate with *kieselguhr G*. Place the dry plate in a tank containing a shallow layer of a mixture of 85 volumes of *acetone*, 10 volumes of *2-phenoxyethanol* and 5 volumes of *polyethylene glycol 300* so that the plate dips about 5 mm beneath the surface of the liquid. Allow the solvent to rise 18 cm above the line of application. Remove the plate from the tank and use it immediately.

*Mobile phase.* Shake a mixture of 100 volumes of *light petroleum (40° to 60°)* and 2 volumes of *diethylamine* with 6 to 8 volumes of *2-phenoxyethanol* until a persistent cloudiness is obtained, decant and use the supernatant layer.

*Test solution.* A 0.2 per cent w/v solution of the substance under examination in *chloroform*.

*Reference solution.* A 0.2 per cent w/v solution of the corresponding *Reference Substance*.

Apply to the plate 2 µl of each solution. Allow the mobile phase to rise 12 cm. Dry the plate in air, and examine in ultraviolet light at 365 nm and observe the fluorescence produced after a few minutes. Spray the plate with *ethanolic sulphuric acid (10 per cent v/v)* and observe the colour produced. The principal spot in the chromatogram obtained with the test solution corresponds in position, fluorescence and colour to that in the chromatogram obtained with the reference solution and has a similar stability for at least 20 minutes after spraying.

Ignore any spot remaining on the line of application. Unless otherwise specified, any secondary spot in the chromatogram



obtained with the test solution is not more intense than the spot in the chromatogram obtained with the reference solution.

### 2.3.4. Related Substances in Barbiturates

Determine by thin-layer chromatography (2.4.17), coating the plate with *silica gel GF254*.

*Mobile phase.* Shake a mixture of 80 volumes of *chloroform*, 15 volumes of *ethanol (95 per cent)* and 5 volumes of *strong ammonia solution*. Use the lower layer.

*Test solution.* A 1.0 per cent w/v solution of the substance under examination in *ethanol (95 per cent)*.

*Reference solution.* A 0.005 per cent w/v solution of the substance under examination in *ethanol (95 per cent)*.

Apply to the plate 20 µl of each solution. After development, examine the plate immediately in ultraviolet light at 254 nm. Spray the plate with *diphenylcarbazone mercuric reagent*, allow it to dry in air and spray with a mixture of 1 volume of freshly prepared *ethanolic potassium hydroxide solution* and 4 volumes of *aldehyde-free ethanol (95 per cent)*. Heat at 100° to 105° for 5 minutes and examine it immediately. By both methods of visualisation, any secondary spot in the chromatogram obtained with the test solution is not more intense than the spot in the chromatogram obtained with the reference solution. Ignore any spot remaining on the line of application.

### 2.3.5. Related Substances in Phenothiazines

Determine protected from light in an atmosphere of nitrogen by thin-layer chromatography (2.4.17), coating the plate with *silica gel GF254*.

*Mobile phase (a).* A mixture of 80 volumes of *cyclohexane*, 10 volumes of *acetone* and 10 volumes of *diethylamine*.

*Mobile phase (b).* A mixture of 85 volumes of *hexane*, 10 volumes of *acetone* and 5 volumes of *diethylamine*.

*Mobile phase (c).* A mixture of 90 volumes of *1-butanol* and 18 volumes of *1 M ammonia*.

*Test solution.* A freshly prepared 2.0 per cent w/v solution of the substance under examination in a mixture of 95 volumes of *methanol* and 5 volumes of *diethylamine*.

*Reference solution.* A freshly prepared 0.010 per cent w/v solution of the substance under examination in a mixture of 95 volumes of *methanol* and 5 volumes of *diethylamine*.

Apply to the plate 10 µl of each solution. Allow the mobile phase to rise 12 cm. Dry the plate in air, and examine in ultraviolet light at 254 nm. Ignore any spot remaining on the line of application. Unless otherwise specified, any secondary spot

in the chromatogram obtained with the test solution is not more intense than the spot in the chromatogram obtained with the reference solution.

### 2.3.6. Related Foreign Steroids

Determine by thin-layer chromatography (2.4.17), coating the plate with *silica gel G*.

*Mobile phase (a).* A mixture of 77 volumes of *dichloromethane*, 15 volumes of *ether*, 8 volumes of *methanol* and 1.2 volumes of *water*.

*Mobile phase (b).* A mixture of 95 volumes of *1,2-dichloroethane*, 5 volumes of *methanol* and 0.2 volume of *water*.

*Test solution.* A 1.5 per cent w/v solution of the substance under examination in a mixture of 90 volumes of *chloroform* and 10 volumes of *methanol*.

*Reference solution (a)* A 1.5 per cent w/v solution of the corresponding *Reference Substance* in the same solvent mixture.

*Reference solution (b).* A solution containing 0.03 per cent w/v each of *prednisolone RS*, *prednisone RS* and *cortisone RS* in the same solvent mixture.

*Reference solution (c).* A solution containing 0.03 per cent w/v each of *prednisolone acetate RS*, *prednisone RS*, *cortisone RS*, and *desoxycortone acetate RS* in the same solvent mixture.

Apply to the plate 1 µl of each solution. Allow the mobile phase to rise 12 cm. Dry the plate in a current of warm air, allow the solvent to evaporate, heat at 105° for 10 minutes, cool and spray with *alkaline blue tetrazolium solution*. The principal spot in the chromatogram obtained with the test solution corresponds to that in the chromatogram obtained with reference solution (a). Any secondary spot in the chromatogram obtained with the test solution is not more intense than the proximate spot in the chromatogram obtained with reference solution (b) or reference solution (c).

### 2.3.7. Related Substances in Sulphonamides

#### Method A

Determine by thin-layer chromatography (2.4.17), coating the plate with *silica gel H*.

*Mobile phase.* A mixture of 50 volumes of *1-butanol* and 10 volumes of *1 M ammonia*.

*Test solution.* Dissolve 1.0 g of the substance under examination in sufficient of a mixture of 90 volumes of *ethanol (95 per cent)* and 10 volumes of *strong ammonia solution* to produce 100 ml.



*Reference solution.* A 0.0050 per cent w/v solution of *sulphanilamide* in the same solvent mixture.

Apply to the plate 10 µl of each solution. After development, dry the plate, heat it at 105° for 10 minutes and spray with a 0.1 per cent v/v solution of *4-dimethylaminobenzaldehyde* in *ethanol* (95 per cent) containing 1 per cent v/v of *hydrochloric acid*. Any secondary spot in the chromatogram obtained with the test solution is not more intense than the spot in the chromatogram obtained with the reference solution.

#### Method B

Determine by thin-layer chromatography (2.4.17), coating the plate with *silica gel H*.

*Mobile phase.* A mixture of 80 volumes of *chloroform*, 8 volumes of *methanol* and 4 volumes of *dimethylformamide*.

*Test solution.* Dissolve 0.25 g of the substance under examination in sufficient of a mixture of 90 volumes of *ethanol* (95 per cent) and 10 volumes of *strong ammonia solution* to produce 100 ml.

*Reference solution.* A 0.00125 per cent w/v solution of *sulphanilamide* in the same solvent mixture.

Apply to the plate 10 µl of each solution. After development, dry the plate in air and spray with *ethanolic sulphuric acid* (10 per cent v/v), heat at 105° for 30 minutes and immediately expose to nitrous fumes in a closed glass tank for 15 minutes. (Nitrous fumes may be generated by adding *sulphuric acid* (50 per cent w/w) dropwise to a solution containing 10 per cent w/v of *sodium nitrite* and 3 per cent w/v of *potassium iodide*). Place the plate in a current of warm air for 15 minutes and spray with a 0.5 per cent w/v solution of *N-(1-naphthyl) ethylenediamine dihydrochloride* in *ethanol* (95 per cent). If necessary, allow to dry and repeat the spraying. Any secondary spot in the chromatogram obtained with the test solution is not more intense than the spot in the chromatogram obtained with the reference solution.

#### Method C

Determine by thin-layer chromatography (2.4.17), coating the plate with *silica gel GF254*.

*Mobile phase.* A mixture of 50 volumes of *dioxan*, 40 volumes of *nitromethane*, 5 volumes of *water* and 3 volumes of *6M ammonia*.

*Test solution.* Dissolve 0.1 g of the substance under examination in 0.5 ml of *strong ammonia solution* and dilute to 5 ml with *methanol*; if the solution is not clear, heat gently until dissolution is complete.

*Reference solution (a).* A 0.40 per cent w/v solution of the substance under examination in a mixture of 24 volumes of *methanol* and 1 volume of *strong ammonia solution*.

*Reference solution (b).* A 0.010 per cent w/v solution of the substance under examination in the same solvent mixture.

*Reference solution (c).* A 0.40 per cent w/v solution of the corresponding *Reference Substance* in the same solvent mixture.

Apply to the plate 5 µl of each solution. After development, dry the plate at 100° to 105° and examine in ultraviolet light at 254 nm. Any secondary spot in the chromatogram obtained with the test solution is not more intense than the spot in the chromatogram obtained with reference solution (b).

### Limit Tests

#### 2.3.8. Aluminium

Place the test solution in a separating funnel and shake with 2 quantities, each of 20 ml, and then with one 10-ml quantity of a 0.5 per w/v solution of *hydroxyquinoline* in *chloroform*. Dilute the combined *chloroform* solutions to 50.0 ml with *chloroform*.

Prepare a standard solution in the same manner using the prescribed reference solution.

Prepare a blank in the same manner using the prescribed blank solution.

Measure the intensity of the fluorescence (2.4.5) of the test solution ( $f_1$ ), of the standard solution ( $f_2$ ) and of the blank ( $f_3$ ), using an excitant beam at 392 nm and a secondary filter with a transmission band centred on 518 nm or a monochromator set to transmit at this wavelength.

The fluorescence of the test solution ( $f_1$ - $f_3$ ) of the test solution is not greater than that of the standard solution ( $f_2$ - $f_3$ ).

#### 2.3.9. Aluminium in Adsorbed Vaccines

Shake the sample thoroughly and transfer a volume containing about 5 mg of aluminium to a 50-ml combustion flask. Add 1 ml of *sulphuric acid*, 0.1 ml of *nitric acid* and a few glass beads or a little pumice powder. Heat the solution until thick, white fumes are evolved. If any charring takes place add a few more drops of *nitric acid* and continue boiling until the solution is colourless. Allow to cool for a few minutes, carefully add 10 ml of *water* and boil until a clear solution is obtained. Allow to cool, add 0.05 ml of *methyl orange solution* and neutralise with *10M sodium hydroxide*. If a precipitate forms, dissolve it by adding, dropwise, sufficient *1 M sulphuric acid*. Transfer the solution to a 250-ml conical flask, rinsing the combustion flask with small quantities of *water* and adding to the main solution. Add 25.0 ml of *0.002 M disodium edetate*, 10ml of *buffer solution pH 4.4* and boil gently for 3 minutes. Add

0.1 ml of *pyridylazonaphthol solution* and titrate the excess of disodium edetate in the hot solution with *0.02 M cupric sulphate* until the colour changes to purplish brown. Repeat the operation omitting the substance under examination.

1 ml of *0.02 M disodium edetate* is equivalent of 0.0005396 g to Al.

### 2.3.10 Arsenic

The limit for arsenic is indicated in the individual monographs in terms of ppm, i.e., the parts of arsenic, As, per million parts (by weight) of the substance under examination.

*All reagents used for the test should have as low a content of arsenic as possible.*

#### Apparatus

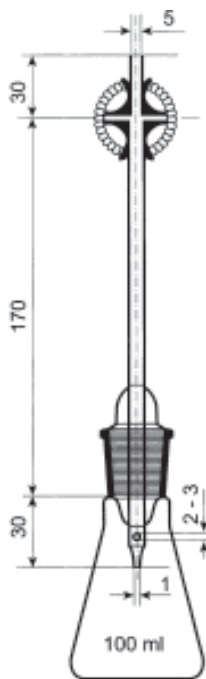

(Dimensions in mm)

Fig. 2.3.10-1: Apparatus for Limit Test For Arsenic

The apparatus (Fig. 2.3.10-1) consists of a 100-ml bottle or conical flask closed with a rubber or ground glass stopper through which passes a glass tube (about 20 cm × 5 mm). The lower part of the tube is drawn to an internal diameter of 1.0 mm, and 15 mm from its tip is a lateral orifice 2 to 3 mm in diameter. When the tube is in position in the stopper the lateral orifice should be at least 3 mm below the lower surface of the stopper. The upper end of the tube has a perfectly flat surface at right angles to the axis of the tube. A second glass tube of the same internal diameter and 30 mm long, with a similar flat surface, is placed in contact with the first and is held in position

by two spiral springs or clips. Into the lower tube insert 50 to 60 mg of *lead acetate cotton*, loosely packed, or a small plug of cotton and a rolled piece of *lead acetate paper* weighing 50 to 60 mg. Between the flat surfaces of the tubes place a disc or a small square of *mercuric chloride paper* large enough to cover the orifice of the tube (15 mm × 15 mm).

#### Method

Into the bottle or conical flask introduce the test solution prepared as directed in the individual monograph, add 5 ml of *1 M potassium iodide* and 10 g of *zinc AsT*. Immediately assemble the apparatus and immerse the flask in a water-bath at a temperature such that a uniform evolution of gas is maintained. After 40 minutes any stain produced on the *mercuric chloride paper* is not more intense than that obtained by treating in the same manner 1.0 ml of *arsenic standard solution* (10 ppm As) diluted to 50 ml with *water*.

### 2.3.11. Calcium in Adsorbed Vaccines

Determine the calcium by atomic emission spectrometry (2.4.3). Homogenise the preparation under examination. To 1.0 ml add 0.2 ml of *dilute hydrochloric acid* and dilute to 3.0 ml with *distilled water*. Measure the absorbance at 620 nm.

### 2.3.12 Chlorides

Dissolve the specified quantity of the substance under examination in *water*, or prepare a solution as directed in the individual monograph and transfer to a Nessler cylinder. Add 10 ml of *dilute nitric acid*, except when nitric acid is used in the preparation of the solution, dilute to 50 ml with *water* and add 1 ml of *0.1 M silver nitrate*. Stir immediately with a glass rod and allow to stand for 5 minutes protected from light. When viewed transversely against a black background any opalescence produced is not more intense than that obtained by treating a mixture of 10.0 ml of *chloride standard solution* (25 ppm Cl) and 5 ml of *water* in the same manner.

### 2.3.13. Heavy Metals

The limit for heavy metals is indicated in the individual monographs in terms of ppm, i.e., the parts of lead, Pb, per million parts (by weight) of the substance under examination.

#### Method A

**Standard solution.** Into a 50-ml Nessler cylinder pipette 1.0 ml of *lead standard solution* (20 ppm Pb) and dilute with *water* to 25 ml. Adjust with *dilute acetic acid* or *dilute ammonia solution* to a pH between 3.0 and 4.0, dilute with *water* to about 35 ml and mix.

**Test solution.** Into a 50-ml Nessler cylinder place 25 ml of the solution prepared for the test as directed in the individual monograph or dissolve the specified quantity of the substance under examination in sufficient *water* to produce 25 ml. Adjust with *dilute acetic acid* or *dilute ammonia solution* to a pH between 3.0 and 4.0, dilute with *water* to about 35 ml and mix.

**Procedure.** To each of the cylinders containing the standard solution and test solution respectively add 10 ml of freshly prepared *hydrogen sulphide solution*, mix, dilute to 50 ml with *water*, allow to stand for 5 minutes and view downwards over a white surface; the colour produced with the test solution is not more intense than that produced with the standard solution.

#### Method B

**Standard solution.** Proceed as directed under Method A.

**Test solution.** Weigh in a suitable crucible the quantity of the substance specified in the individual monograph, add sufficient *sulphuric acid* to wet the sample, ignite carefully at a low temperature until thoroughly charred. Add to the charred mass 2 ml of *nitric acid* and 5 drops of *sulphuric acid* and heat cautiously until white fumes are no longer evolved. Ignite, preferably in a muffle furnace, at 500° to 600°, until the carbon is completely burnt off. Cool, add 4 ml of *hydrochloric acid*, cover, digest on a water-bath for 15 minutes, uncover and slowly evaporate to dryness on a water-bath. Moisten the residue with 1 drop of *hydrochloric acid*, add 10 ml of hot *water* and digest for 2 minutes. Add *ammonia solution* dropwise until the solution is just alkaline to *litmus paper*, dilute to 25 ml with *water* and adjust with *dilute acetic acid* to a pH between 3.0 and 4.0. Filter, if necessary, rinse the crucible and the filter with 10 ml of *water*, combine the filtrate and washings in a 50-ml Nessler cylinder, dilute with *water* to about 35 ml and mix.

**Procedure:** Proceed as directed under Method A.

#### Method C

**Standard solution.** Into a 50-ml Nessler cylinder pipette 1.0 ml of *lead standard solution* (20 ppm Pb), add 5 ml of *dilute sodium hydroxide solution*, dilute with *water* to 50 ml and mix.

**Test solution.** Into a 50-ml Nessler cylinder place 25 ml of the solution prepared for the test as directed in the individual monograph, or dissolve the specified quantity of the substance under examination in a mixture of 20 ml of *water* and 5 ml of *dilute sodium hydroxide solution*. Dilute with *water* to 50 ml and mix.

**Procedure.** To each of the cylinders containing the standard solution and the test solution respectively add 5 drops of *sodium sulphide solution*, mix, allow to stand for 5 minutes and view downwards over a white surface; the colour

produced with the test solution is not more intense than that produced with the standard solution.

#### Method D

**Standard solution.** Into a small Nessler cylinder pipette 10.0 ml of either *lead standard solution* (1 ppm Pb) or *lead standard solution* (2 ppm Pb).

**Test solution.** Prepare as directed in the individual monograph and pipette 12 ml into a small Nessler cylinder.

**Procedure.** To the cylinder containing the standard solution add 2.0 ml of the test solution and mix. To each of the cylinders add 2 ml of *acetate buffer pH 3.5*, mix, add 1.2 ml of *thioacetamide reagent*, allow to stand for 2 minutes and view downwards over a white surface; the colour produced with the test solution is not more intense than that produced with the standard solution.

### 2.3.14. Iron

Dissolve the specified quantity of the substance under examination in *water*, or prepare a solution as directed in the monograph, and transfer to a Nessler cylinder. Add 2 ml of a 20 per cent w/v solution of *iron-free citric acid* and 0.1 ml of *thioglycollic acid*, mix, make alkaline with *iron-free ammonia solution*, dilute to 50 ml with *water* and allow to stand for 5 minutes. Any colour produced is not more intense than that obtained by treating in the same manner 2.0 ml of *iron standard solution* (20 ppm Fe) in place of the solution under examination.

### 2.3.15. Lead

The limit for lead is indicated in the individual monograph in terms of ppm, i.e., the parts of lead, Pb, per million parts (by weight) of the substance under examination.

The following method is based on the extraction of lead by solutions of dithizone.

*All reagents used for the test should have as low a content of lead as practicable. All reagent solutions should be stored in containers of borosilicate glass. Glassware should be rinsed thoroughly with warm dilute nitric acid followed by water.*

#### Method

Transfer the volume of the prepared sample directed in the monograph to a separator and, unless otherwise directed in monograph, add 6 ml of *ammonium citrate solution Sp* and 2 ml of *hydroxylamine hydrochloride solution Sp*. (For the determination of lead in iron salts use 10 ml of *ammonium citrate solution Sp*). Add two drops of *phenol red solution* and make the solution just alkaline (red in colour) by the addition of *strong ammonia solution*. Cool the solution if

necessary and add 2 ml of *potassium cyanide solution Sp*. Immediately extract the solution with several quantities, each of 5 ml, of *dithizone extraction solution*, draining off each extract into another separating funnel, until the dithizone extraction solution retains its green colour. Shake the combined dithizone solution for 30 seconds with 30 ml of a 1 per cent v/v solution of *nitric acid* and discard the chloroform layer. Add to the acid solution exactly 5 ml of *dithizone standard solution* and shake for 30 seconds; the colour of the chloroform layer is not more intense than that obtained by treating in the same manner a volume of *lead standard solution (1 ppm Pb)* equivalent to the amount of lead permitted in the substance under examination, in place of the solution under examination.

### 2.3.16. Potassium

To 10 ml of the prescribed solution add 2 ml of a freshly prepared 1 per cent w/v solution of *sodium tetraphenylborate*. Prepare a standard solution in the same manner using a mixture of *potassium standard solution (20 ppm K)* and 5 ml of *water*.

After 5 minutes, any opalescence in the test solution is not more intense than in the standard solution.

### 2.3.17. Sulphates

*NOTE* — *The solutions used for this test should be prepared with distilled water.*

To 1.0 ml of a 25.0 per cent w/v solution of *barium chloride* in a Nessler cylinder add 1.5 ml of *ethanolic sulphate standard solution (10 ppm SO<sub>4</sub>)*, mix and allow to stand for 1 minute. Add 15 ml of the solution prepared as directed in the monograph or a solution of the specified quantity of the substance under examination in 15 ml of *water* and 0.15 ml of *5 M acetic acid*. Add sufficient *water* to produce 50 ml, stir immediately with a glass rod and allow to stand for 5 minutes. When viewed transversely against a black background any opalescence produced is not more intense than that obtained by treating in the same manner 15 ml of *sulphate standard solution (10 ppm SO<sub>4</sub>)* in place of the solution under examination.

### 2.3.18. Sulphated ash

Heat a silica or platinum crucible to redness for 10 minutes, allow to cool in a desiccator and weigh. Unless otherwise specified in the individual monograph, transfer to the crucible 1 g of the substance under examination and weigh the crucible and the contents accurately. Ignite, gently at first, until the substance is thoroughly charred. Cool, moisten the residue with 1 ml of *sulphuric acid*, heat gently until the white fumes are no longer evolved and ignite at  $800^{\circ} \pm 25^{\circ}$  until all black particles have disappeared. Conduct the ignition in a place

protected from air currents. Allow the crucible to cool, add a few drops of *sulphuric acid* and heat. Ignite as before, allow to cool and weigh. Repeat the operation until two successive weighings do not differ by more than 0.5 mg.

### 2.3.19. Total Ash

#### Method A. For crude vegetable drugs

Unless otherwise stated in the individual monograph, weigh accurately 2 to 3 g of the air-dried drug in a tared platinum or silica dish and incinerate at a temperature not exceeding  $450^{\circ}$  until free from carbon, cool and weigh. If a carbon-free ash is not obtained, wash the charred mass with hot *water*, collect the residue on an ashless filter paper, incinerate the residue and filter paper until the ash is white or nearly white, add the filtrate to the dish, evaporate to dryness and ignite at a temperature not exceeding  $450^{\circ}$ . Calculate the percentage of ash on the dried drug basis.

#### Method B. For all other substances

Heat a platinum or silica crucible to red heat for 30 minutes, allow to cool in a desiccator and weigh. Unless otherwise specified in the individual monograph, weigh accurately about 1 g of the substance under examination and evenly distribute it in the crucible. Dry at  $100^{\circ}$  to  $105^{\circ}$  for 1 hour and ignite to constant weight in a muffle furnace at  $600^{\circ} \pm 25^{\circ}$ . Allow the crucible to cool in a desiccator after each ignition. The material should not catch fire at any time during the procedure. If after prolonged ignition a carbon-free ash cannot be obtained proceed as directed in method A. Ignite to constant weight. Calculate the percentage of ash on the dried basis.

#### Acid-insoluble ash

Use Method C unless otherwise directed.

**Method C.** Boil the ash (Method A or B) with 25 ml of *2M hydrochloric acid* for 5 minutes, collect the insoluble matter in a Gooch crucible or on an ashless filter paper, wash with hot *water*, ignite, cool in a desiccator and weigh. Calculate the percentage of acid-insoluble ash on the dried drug basis.

**Method D.** Place the ash (Method A or B), or the sulphated ash (2.3.18), as directed in the individual monograph, in a crucible, add 15 ml of *water* and 10 ml of *hydrochloric acid*, cover with a watch glass, boil for 10 minutes, and allow to cool. Collect the insoluble matter on an ashless filter paper, wash with hot *water* until the filtrate is neutral, ignite to dull redness, cool in an a desiccator and weigh. Calculate the percentage of acid-insoluble ash on the dried basis.

#### Water-soluble ash

Boil the ash (Method A or B) for 5 minutes with 25 ml of *water*, collect the insoluble matter in a Gooch crucible or an ashless



filter paper, wash with hot *water*, and ignite for 15 minutes at a temperature not exceeding 450°. Subtract the weight of the insoluble matter from the weight of the ash; the difference in weight represents the water-soluble ash. Calculate the percentage of water-soluble ash on the dried basis.

### 2.3.20. Free Formaldehyde

Use Method A unless otherwise specified.

#### Method A

To 1.0 ml of a ten-fold dilution of the preparation under examination in a test-tube add 4.0 ml of *water* and 5.0 ml of *acetylacetone reagent*. Warm in a water-bath at 40° and allow to stand for 40 minutes. The solution is not more intensely coloured than a reference solution prepared at the same time and in the same manner using 1.0 ml of a solution containing 0.002 per cent w/v of formaldehyde, CH<sub>2</sub>O, in place of the dilution of the preparation. The comparison should be made examining the tubes down their vertical axes.

#### Method B

To 1.0 ml of ten-fold dilution of the preparation under examination in a test-tube add 2.0 ml of *water*, 1.0 ml of a 1 per cent w/v solution of *phenylhydrazine hydrochloride*, 0.5 ml of a 5 per cent w/v solution of *potassium ferricyanide* and 1.0 ml of *hydrochloric acid* and allow to stand for 15 minutes. The solution is not more intensely coloured than a reference solution prepared at the same time and in the same manner using 1.0 ml of a solution containing 0.002 per cent w/v of formaldehyde, CH<sub>2</sub>O, in place of the dilution of the preparation. The comparison should be made examining the tubes down their vertical axes.

### 2.3.21. N,N-Dimethylaniline

Determine by gas chromatography (2.4.13).

#### Method A

*Internal standard solution.* Unless otherwise specified in the individual monograph, dissolve 50 mg of *naphthalene* in sufficient *cyclohexane* to produce 50 ml. Dilute 5 ml of this solution to 100.0 ml with *cyclohexane*.

*Test solution (a).* Unless otherwise specified in the individual monograph, weigh accurately about 1.0 g of the substance under examination and transfer to a centrifuge tube, add 5 ml of 1M *sodium hydroxide*, swirl to dissolve the sample, add 1.0 ml of *cyclohexane*, shake vigorously for 1 minute, and centrifuge. Use the upper layer.

*Test solution (b).* Unless otherwise specified in the individual monograph, weigh accurately about 1.0 g of the substance

under examination and transfer to a centrifuge tube, add 5 ml of 1 M *sodium hydroxide*, swirl to dissolve the sample, add 1.0 ml of the internal standard solution, shake vigorously for 1 minute, and centrifuge. Use the upper layer.

*Reference solution.* Unless otherwise specified in the individual monograph, weigh accurately about 50.0 mg of *N, N-dimethylaniline*, add 2 ml of *hydrochloric acid* and 20 ml of *water*, shake to dissolve and dilute to 50.0 ml with *water*. Dilute 5.0 ml of this solution to 250.0 ml with *water*. To 1.0 ml of the latter solution in a stoppered centrifuge tube add 5 ml of 1 M *sodium hydroxide* and 1.0 ml of the internal standard solution. Stopper the tube and shake vigorously for 1 minute. Centrifuge if necessary and use the upper layer.

#### Chromatographic system

- a glass column 2 m × 2 mm, packed with silanised diatomaceous support (125 to 180 mesh) impregnated with 3 per cent w/w polymethylphenylsiloxane,
- temperature: column. 120°, inlet port and detector. 150°,
- flow rate 30 ml per minute of nitrogen (carrier gas).

Inject 1 µl of each of the solutions. Record the chromatograms and measure the areas for the major peaks. In the chromatogram obtained with test solution (b) the ratio of the area of any peak due to *N, N-dimethylaniline* to the area of the peak due to the internal standard is not greater than the corresponding ratio in the chromatogram obtained with internal standard solution.

#### Method B

*Internal standard solution.* Unless otherwise stated in the individual monograph, dissolve 75 mg of *N, N-diethylaniline* in a mixture of 2 ml of *hydrochloric acid* and 20 ml of *water* and add sufficient *water* to produce 50 ml. Dilute 2 ml of the resulting solution to 100.0 ml with *water*.

*Test solution (a).* Unless otherwise specified in the individual monograph, weigh accurately about 1.0 g of the substance under examination and transfer to a centrifuge tube, add 3 ml of *dilute sodium hydroxide solution*, swirl to dissolve the sample, add 1 ml of *cyclohexane*, shake vigorously for 1 minute and centrifuge if necessary. Use the clear upper layer.

*Test solution (b).* Prepare in the same manner as test solution (a) but using 1 ml of internal standard solution instead of 1 ml cyclohexane.

*Reference solution.* Unless otherwise specified in the individual monograph, dissolve 50 mg of *N, N-dimethylaniline* in a mixture of 2 ml of *hydrochloric acid* and 20 ml of *water* and add sufficient *water* to produce 50 ml. Dilute 2 ml of the resulting solution to 100.0 ml with *water*. To 1 ml of the resulting solution add 1 ml of the internal standard solution, 1 ml of



dilute sodium hydroxide solution and 1 ml of cyclohexane, shake vigorously for 1 minute, centrifuge if necessary and use the clear upper layer.

Chromatographic system

- a glass column 1.5 m × 4 mm, packed with 3 per cent w/w of cyanoethyl-silicone gum (XE-60 is suitable) on acid-washed silanised diatomaceous earth (80 to 100 mesh),
- temperature: column. 80°, inlet port and detector. 150°,
- flow rate 30 ml per minute of nitrogen (carrier gas).

Inject 1 µl of each of the solutions. Record the chromatograms and measure the areas for the major peaks. In the chromatogram obtained with test solution (b) the ratio of the area of any peak due to *N,N*-dimethylaniline to the area of the peak due to the internal standard is not greater than the corresponding ratio in the chromatogram obtained with internal standard solution.

### 2.3.22. Acetyl Value

The acetyl value is the number which expresses in milligrams the amount of potassium hydroxide required to neutralise the acetic acid liberated by the hydrolysis of 1 g of the acetylated substance.

#### Method

Determination the saponification value of the substance under examination (2.3.37).

Acetylate the substance under examination by the following method. Place 10 g with 20 ml of *acetic anhydride* in a long-necked, round-bottomed 200-ml flask attached to a reflux air condenser. Support the flask on a sheet of heat-resistant material in which a hole of about 4 cm in diameter has been cut and heat it with a small, naked flame, not more than 25 mm in height and which does not impinge on the bottom of the flask. Boil gently for 2 hours, allow to cool, pour into 600 ml of *water* contained in a large beaker, add 0.2 g of *pumice powder* and boil for 30 minutes. Cool, transfer to a separator and discard the lower layer. Wash the acetylated product with three or more quantities, each of 50 ml, of a warmed saturated solution of *sodium chloride* until the washings are no longer acid to *litmus paper*. Finally shake with 20 ml of warm *water* and remove the aqueous layer as completely as possible. Pour the acetylated substance into a small dish, add 1 g of powdered *anhydrous sodium sulphate*, stir thoroughly and filter through a dry pleated filter. Determine the saponification value of the acetylated substance.

Calculate the Acetyl value from the expression

$$\text{Acetyl value} = 1335(b - a)/(1335 - a)$$

Where,  $a$  = saponification value of the substance;  
 $b$  = saponification value of the acetylated substance.

### 2.3.23. Acid Value

The acid value is the number which expresses in milligrams the amount of potassium hydroxide necessary to neutralise the free acids present in 1 g of the substance.

#### Method

Unless otherwise specified in the individual monograph, dissolve about 10 g of the substance under examination, accurately weighed, in 50 ml of a mixture of equal volumes of *ethanol (95 per cent)* and *ether*, previously neutralised with *0.1 M potassium hydroxide to phenolphthalein solution*. If the sample does not dissolve in the cold solvent, connect the flask with a reflux condenser and warm slowly, with frequent shaking, until the sample dissolves. Add 1 ml of *phenolphthalein solution* and titrate with *0.1 M potassium hydroxide* until the solution remains faintly pink after shaking for 30 seconds. Calculate the acid value from the expression

$$\text{Acid value} = 5.61 n/w$$

Where,  $n$  = the number of ml of *0.1 M potassium hydroxide* required;  
 $w$  = the weight, in g, of the substance.

*NOTE* — If the oil has been saturated with carbon dioxide for the purpose of preservation, gently reflux the solution of the oil in ethanol (95 per cent) and ether for 10 minutes before titration. The oil may be freed from the carbon dioxide by exposing it in a shallow dish in a vacuum desiccator for 24 hours before weighing the sample.

### 2.3.24. Cineole

Weigh 3.0 g of the substance under examination, freshly dried over *anhydrous sodium sulphate*, into a dry test-tube and add 2.1 g of melted *o-cresol*. Place the tube in the apparatus for the freezing point (2.4.11), and allow to cool, stirring continuously. When crystallisation takes place there is a small rise in temperature; note the highest temperature reached ( $t_1$ ).

Re-melt the mixture on a water-bath ensuring that the temperature does not exceed  $t_1$  by more than 5° and place the tube in the apparatus maintained at a temperature 5° below  $t_1$ . When crystallisation takes place, or when the temperature of the mixture has fallen 3° below  $t_1$ , stir continuously; note the highest temperature at which the mixture freezes ( $t_2$ ). Repeat the operation until the two highest values obtained for  $t_2$  do not differ by more than 0.2°. If supercooling occurs, induce crystallisation by the addition of a small crystal of a complex

consisting of 3.0 g of *cineole* and 2.1 g of melted *o-cresol*. If  $t_2$  is below 27.4°, repeat the determination after the addition of 5.1 g of the complex.

Determine the percentage w/w of cineole corresponding to the freezing point ( $t_2$ ) from Table 1, obtaining intermediate values by interpolation. If 5.1 g of the cineole-*o-cresol* complex was added, calculate the percentage w/w of cineole from the expression  $2(A-50)$ , where A is the value corresponding to a freezing point of  $t_2$  taken from the table (see below).

Table

$t_2^\circ$	Cineole per cent w/w	$t_2^\circ$	Cineole per cent w/w
24	45.5	40	67.0
25	47.0	41	68.5
26	48.5	42	70.0
27	49.5	43	72.5
28	50.5	44	74.0
29	52.0	45	76.0
30	53.5	46	78.0
31	54.5	47	80.0
32	56.0	48	82.0
33	57.0	49	84.0
34	58.5	50	86.0
35	60.0	51	88.5
36	61.0	52	91.0
37	62.5	53	93.5
38	63.5	54	96.0
39	65.0	55	99.0

### 2.3.25. Esters

Boil a convenient quantity of *ethanol (95 per cent)* thoroughly to expel carbon dioxide and neutralise it to *phenolphthalein solution*. Unless otherwise stated in the individual monograph, weigh accurately about 2 g or other suitable quantity of the substance under examination so that the volume of 0.5 M *ethanolic potassium hydroxide* added is at least twice that theoretically required, dissolve it in 5 ml of the neutralised ethanol contained in a hard-glass flask and neutralise the free acid in the solution with 0.1 M *ethanolic potassium hydroxide* using 0.2 ml of *phenolphthalein solution* as indicator. Add 25.0 ml of 0.5 M *ethanolic potassium hydroxide* and boil under a reflux condenser on a water-bath for 1 hour. Add 20 ml of *water* and titrate the excess of alkali with 0.5 M *hydrochloric acid* using a further 0.2 ml of *phenolphthalein solution* as indicator. Repeat the operation without the substance under examination. The difference between the titrations represents the alkali required to saponify the esters.

### 2.3.26. Ester Value

The ester value is the number of milligrams of potassium hydroxide required to saponify the esters present in 1 g of the substance.

Determine the acid value (2.3.23), and the saponification value (2.3.37), of the substance under examination. Calculate the ester value from the expression

$$\text{Ester value} = \text{Saponification value} - \text{Acid value.}$$

### 2.3.27 Hydroxyl Value

The hydroxyl value is the number of milligrams of potassium hydroxide required to neutralise the acid combined by acylation in 1 g of the substance.

Use method A unless otherwise specified.

#### Method A

Unless otherwise specified in the individual monograph, weigh accurately the quantity of the substance under examination, stated in the table (see below), in a 150-ml acetylation flask fitted with a condenser and add the quantity of *pyridine-acetic anhydride reagent* stated in the table. Boil for 1 hour on a water-bath, adjusting the level of the *water* to maintain it 2 to 3 cm above the level of the liquid in the flask all through. Cool, add 5 ml of *water* through the top of the condenser; if this causes cloudiness, add sufficient *pyridine* to produce a clear liquid. Shake, replace in the water-bath for 10 minutes, remove and cool. Rinse the condenser and the walls of the flask with 5 ml of *ethanol (95 per cent)*, previously neutralised to *dilute phenolphthalein solution*. Titrate with 0.5 M *ethanolic potassium hydroxide* using *dilute phenolphthalein solution* as indicator. Perform a blank determination.

Table

Presumed hydroxyl value	Quantity of substance (g)	Volume of pyridine acetic anhydride reagent (ml)
10 to 100	2.0	5.0
101 to 150	1.5	5.0
151 to 200	1.0	5.0
201 to 250	0.75	5.0
251 to 300	0.60	5.0
	or	or
	1.20	10.0
01 to 350	1.00	10.0
351 to 700	0.75	15.0
701 to 950	0.5	15.0

Calculate the hydroxyl value from the expression

$$\text{Hydroxyl value} = \text{Acid Value} + 28.05 v/w$$

Where,  $v$  = difference, in ml, between the titrations;  
 $w$  = weight, in g, of the substance.

#### Method B

Weigh accurately the specified quantity of the substance under examination into a flask fitted with a reflux condenser, add 12 g of *stearic anhydride* and 10 ml of *xylene* and heat under reflux for 30 minutes. Cool, add a mixture of 40 ml of *pyridine* and 4 ml of *water*, heat under reflux for a further 30 minutes and titrate the hot solution with 1 M *potassium hydroxide* using *dilute phenolphthalein solution* as indicator. Perform a blank determination.

Calculate the hydroxyl value from the expression

$$\text{Hydroxyl value} = 56.11 v/w$$

Where,  $v$  = difference, in ml, between the titrations;  
 $w$  = weight, in g, of the substance.

### 2.3.28. Iodine Value

The iodine value is the number which expresses in grams the quantity of halogen, calculated as iodine, which is absorbed by 100 g of the substance under the described conditions. It may be determined by any of the following methods.

#### Method A

##### (Iodine Monochloride Method or Wijs Method)

Place an accurately weighed quantity of the substance under examination in a dry 500-ml iodine flask, add 10 ml of *carbon tetrachloride* and dissolve. Add 20 ml of *iodine monochloride solution*, insert the stopper and allow to stand in the dark at a temperature between 15° and 25° for 30 minutes. Place 15 ml of *potassium iodide solution* in the cup top, carefully remove the stopper, rinse the stopper and the sides of the flask with 100 ml of *water*, shake and titrate with 0.1 M *sodium thiosulphate* using *starch solution*, added towards the end of the titration, as indicator. Note the number of ml required ( $a$ ). Repeat the operation without the substance under examination and note the number of ml required ( $b$ ).

Calculate the iodine value from the expression

$$\text{Iodine value} = 1.269 (b - a)/w$$

where,  $w$  = weight, in g, of the substance.

The approximate weight, in g, of the substance to be taken may be calculated by dividing 20 by the highest expected iodine value. If more than half the available halogen is absorbed, the test must be repeated with a smaller quantity of the substance.

#### Method B

##### (Iodine Monobromide Method or Hanus Method)

Unless otherwise specified, weigh accurately the quantity of the substance under examination, stated in the table (see below), place it in a dry 300-ml iodine flask or which has been rinsed with *glacial acetic acid* unless otherwise specified in the monograph. Add 15 ml of *chloroform* and dissolve. Add slowly from a burette 25.0 ml of *iodine monobromide solution*, insert the stopper, allow to stand in the dark for 30 minutes, unless otherwise specified in the monograph, shaking frequently. Add 10 ml of *potassium iodide solution* and 100 ml of *water* and titrate with 0.1 M *sodium thiosulphate* using *starch solution*, added towards the end of the titration, as indicator. Note the number of ml required ( $a$ ). Repeat the operation without the substance under examination and note the number of ml required ( $b$ ). Calculate the iodine value from the expression given under Method A.

The approximate weight, in g, of the substance to be taken, unless otherwise specified in the monograph, may be calculated from the table.

Table

Presumed Iodine Value	Quantity of the substance (g)
Less than 20	1.0
21 to 60	0.25 to 0.5
61 to 100	0.15 to 0.25
More than 100	0.10 to 0.15

#### Method C

##### (Pyridine Bromide Method)

Place an accurately weighed quantity of the substance under examination in a dry iodine flask, add 10 ml of *carbon tetrachloride* and dissolve. Add 25 ml of *pyridine bromide solution*, allow to stand for 10 minutes in the dark and complete the determination described under Method A beginning at the words "Place 15 ml of...".

The approximate weight, in g, of the substance to be taken may be calculated by dividing 12.5 by the highest expected iodine value. If more than half the available halogen is absorbed, the test must be repeated with a smaller quantity of the substance.

### 2.3.29. Methoxyl

#### Apparatus

The apparatus consists of a 50-ml round-bottomed boiling flask into which is sealed a capillary side arm of 1 mm diameter to provide an inlet for a stream of *carbon dioxide* or *nitrogen*. The flask is also fitted with an upright air condenser about 25

cm long and about 9 mm in diameter, bent through 180° at the top and terminating in a glass capillary of 2 mm diameter dipping into a small scrubber containing about 2 ml of *water*. The outlet from the scrubber is a tube of about 7 mm diameter which dips below the surface of the liquid in the first of two receivers connected in series.

#### Method

Weigh accurately a quantity of the substance under examination containing approximately 50 mg of methyl iodide and place it in the boiling flask. Add a little pumice, 2.5 ml of melted *phenol* and 5 ml of *hydriodic acid* and connect the flask with the remainder of the apparatus. The first receiver contains about 6 ml and the second receiver about 4 ml of a 10 per cent w/v solution of *potassium acetate* in *glacial acetic acid* to which 0.2 ml of *bromine* has been added. Pass a slow uniform stream of *carbon dioxide* or *nitrogen* through the side arm of the boiling flask and gently heat the liquid by means of a mantled micro-burner at such a rate that the vapours of the boiling liquid rise half-way up the condenser. For most substances 30 minutes is sufficient to complete the reaction and sweep out the apparatus. Wash the contents of both receivers into a 250-ml glass-stoppered conical flask containing 5 ml of a 25 per cent w/v solution of *sodium acetate*, adjust the volume of the liquid to approximately 125 ml and add 0.3 ml of *formic acid*. Rotate the flask until the colour due to the bromine is discharged, add 0.6 ml of *formic acid*, stopper the flask and mix the contents thoroughly so as to remove any excess of bromine from the vapour above the liquid in the flask. After allowing to stand for 1 to 2 minutes, add 1 g of *potassium iodide* and a few ml of *1 M sulphuric acid* and titrate the liberated iodine with *0.1 M sodium thiosulphate*. Perform a blank titration and make any necessary correction.

1 ml of *0.1 M sodium thiosulphate* is equivalent to 0.0005172 g of methoxyl (CH<sub>3</sub>O).

### 2.3.30. Nitrogen

Use method E for substances containing 2 mg or less of nitrogen.

#### Method A

Weigh accurately the quantity of the substance under examination specified in the individual monograph or a quantity equivalent to about 35 mg of nitrogen into a 200-ml long-necked flask and add 3 g of *anhydrous sodium sulphate*, 0.3 g of *nitrogen-free mercuric oxide* and 20 ml of *nitrogen-free sulphuric acid*, unless otherwise specified in the monograph. Heat the mixture over a small flame until colourless and boil gently for a further 2 hours, unless otherwise directed in the monograph, care being taken to prevent the upper part

of the flask from getting overheated. Cool, cautiously dilute to about 75 ml with *water* and add a piece of *granulated zinc* and a solution containing 1.5 g of *sodium hydroxide* per ml of the sulphuric acid used and 2 g of *sodium thiosulphate* in 25 ml of *water*. Ensure that before distillation the mixture is strongly alkaline by increasing, if necessary, the quantity of *sodium hydroxide*. Immediately connect the flask to a distillation apparatus, mix the contents, distil the liberated ammonia into 50.0 ml of *0.1 M sulphuric acid* and titrate the excess of acid with *0.1 M sodium hydroxide* using *methyl red-methylene blue* solution as indicator. Repeat the operation without the substance under examination. The difference between the titrations represents the ammonia liberated by the substance under examination.

1 ml of *0.1 M sulphuric acid* is equivalent to 0.002802 g of N.

#### Method B

Weigh accurately the quantity of the substance under examination specified in the monograph or a quantity equivalent to about 35 mg of nitrogen into a 200-ml long-necked flask, add 20 ml of *nitrogen-free sulphuric acid*, unless otherwise specified in the monograph, and heat for 15 minutes. Add 3 g of *anhydrous sodium sulphate* and 0.3 g of *nitrogen-free mercuric oxide* and complete Method A, beginning at the words "Heat the mixture...".

1 ml of *0.1 M sulphuric acid* is equivalent to 0.002802 g of N.

#### Method C

Weigh accurately the quantity of the substance under examination specified in the monograph or a quantity equivalent to about 15 mg of nitrogen into a 200-ml long-necked flask and add 1 g of a powdered mixture of 10 parts of *anhydrous sodium sulphate* or *potassium sulphate* and 1 part of *cupric sulphate*. Add 10 ml of *nitrogen-free sulphuric acid*, mix, and carefully add 1 ml of *hydrogen peroxide solution (100 vol)* carefully down the wall of the flask. Heat until the solution becomes clear green in colour or almost colourless for 30 minutes. Cool, carefully add 20 ml of *water*, cool again and connect the flask to a distillation apparatus. Add 50 ml of *10 M sodium hydroxide* and distil immediately by passing steam through the flask. Collect the distillate in 25.0 ml of *0.1 M hydrochloric acid* and titrate the excess of acid with *0.1 M sodium hydroxide* using *methyl red-methylene blue solution* as indicator. Repeat the operation using 25 mg of *anhydrous dextrose* in place of the substance under examination. The difference between the titrations represents the ammonia liberated by the substance under examination.

1 ml of *0.1 M hydrochloric acid* is equivalent to 0.001401 g of N.



**Method D** (*When nitrates and nitrites are present*)

Weigh accurately the quantity of the substance under examination specified in the monograph or a quantity equivalent to about 15 mg of nitrogen into a 200-ml long-necked flask, add 10 ml of *nitrogen-free sulphuric acid* in which 0.2 g of *salicylic acid* has been previously dissolved and mix. Allow the mixture to stand for 30 minutes with frequent shaking and add 1 g of a powdered mixture of 10 parts of *anhydrous sodium sulphate* or *potassium sulphate* and 1 part of *cupric sulphate*, mix and carefully add 1 ml of *hydrogen peroxide solution (100 vol)* down the wall of the flask. Complete Method C beginning at the words "Heat until the solution....".

1 ml of 0.1 M *hydrochloric acid* is equivalent to 0.001401 g of N.

**Method E**

**Apparatus:** A unit of the type generally known as semi-micro Kjeldahl apparatus.

**Method**

Weigh accurately a quantity of the substance under examination equivalent to about 2 mg of nitrogen into the digestion flask of the apparatus. Add 1 g of a powdered mixture of 10 parts of *anhydrous sodium sulphate* or *potassium sulphate* and 1 part of *cupric sulphate* and wash down any adhering material from the neck of the flask with *water*. Add 7 ml of *nitrogen-free sulphuric acid* and 1 ml of *hydrogen peroxide solution (100 vol)* carefully down the wall of the flask. (Do not add hydrogen peroxide during the digestion). Heat until the solution has a clear blue colour and the sides of the flask are free from carbonaceous matter. Cool, add carefully 20 ml of *water*, cool the solution and arrange for steam distillation. Add through the funnel 30 ml of 10 M *sodium hydroxide*, rinse the funnel with 10 ml of *water*, tightly close the apparatus and begin the distillation with steam immediately. Collect the distillate in 25.0 ml of 0.01 M *sulphuric acid*, continue the distillation until the distillate measures about 100 ml. Titrate the distillate with 0.01 M *sodium hydroxide* using *methyl red-methylene blue solution* as indicator. Repeat the operation without the substance under examination. The difference between the titrations represents the ammonia liberated by the substance under examination.

1 ml of 0.01 M *sulphuric acid* is equivalent to 0.0002802 g of N.

**Method F** (*Determination of Protein in Blood Products*)

For dried blood products prepare a solution of the preparation as directed in the monograph.

To a volume expected to contain about 0.1 g of protein add sufficient *saline solution* to produce 20 ml. To 2 ml of the

resulting solution, in a 75-ml boiling tube, add 2 ml of a solution containing 75.0 per cent v/v of *nitrogen-free sulphuric acid*, 4.5 per cent w/v of *potassium sulphate* and 0.5 percent w/v of *copper (II) sulphate*, mix and loosely stopper the tube. Heat gradually to boiling, boil vigorously for 1.5 hours and cool. If the solution is not clear add 0.25 ml of *hydrogen peroxide solution (20 vol)*, continue heating until a clear solution is produced and cool. During heating, take precautions to ensure that the upper part of the tube is not overheated.

Transfer the solution to a distillation apparatus using three 3-ml quantities of *water*, add 10 ml of 10M *sodium hydroxide* and distil rapidly for 4 minutes, collecting the distillate in a mixture of 5 ml of a saturated solution of *boric acid* and 5 ml of *water* and keeping the tip of the condenser below the level of the acid. Lower the collection flask so that the condenser can drain freely and continue the distillation for a further 1 minute. Titrate with 0.02M *hydrochloric acid* using *methyl red mixed solution* as indicator ( $V_1$  ml).

To a further volume of the preparation under examination, or of the solution prepared from it, expected to contain about 0.1 g of protein, add 12 ml of *saline solution*, 2 ml of a 7.5 per cent w/v solution of *sodium molybdate* and 2 ml of a mixture of 1 volume of *nitrogen-free sulphuric acid* and 30 volumes of *water*. Shake, allow to stand for 15 minutes, add sufficient *water* to produce 20 ml, shake again and centrifuge. Using 2 ml of the resulting clear supernatant liquid repeat the procedure described above beginning at the words 'in a 75-ml boiling tube...' ( $V_2$  ml). Calculate the protein content in mg per ml of the preparation under examination, using the expression  $6.25 \times 0.280 (V_1 - V_2)$  and taking into account the initial dilution.

**2.3.31 Nitrite Titration**

The following method is suitable for the determination of most of the pharmacopoeial sulphonamide drugs and their preparations. It may also be used for other pharmacopoeial drugs for which nitrite titration is recommended.

**Apparatus**

A suitable open vessel of about 200 ml capacity is fitted with two similar clean platinum electrodes and a stirrer. The electrodes may be of platinum foil 0.5 cm square and should be placed 1.5 cm apart. They may be cleaned by immersing for a few seconds in boiling *nitric acid* containing a small amount of *ferric chloride*, followed by washing with *water*.

The polarising voltage may be obtained from a 1.5 volt dry cell and potentiometer or other convenient device which enables a small but definite voltage to be applied across the electrodes. The current flowing in the system is indicated by a series galvanometer which should have adequate sensitivity.



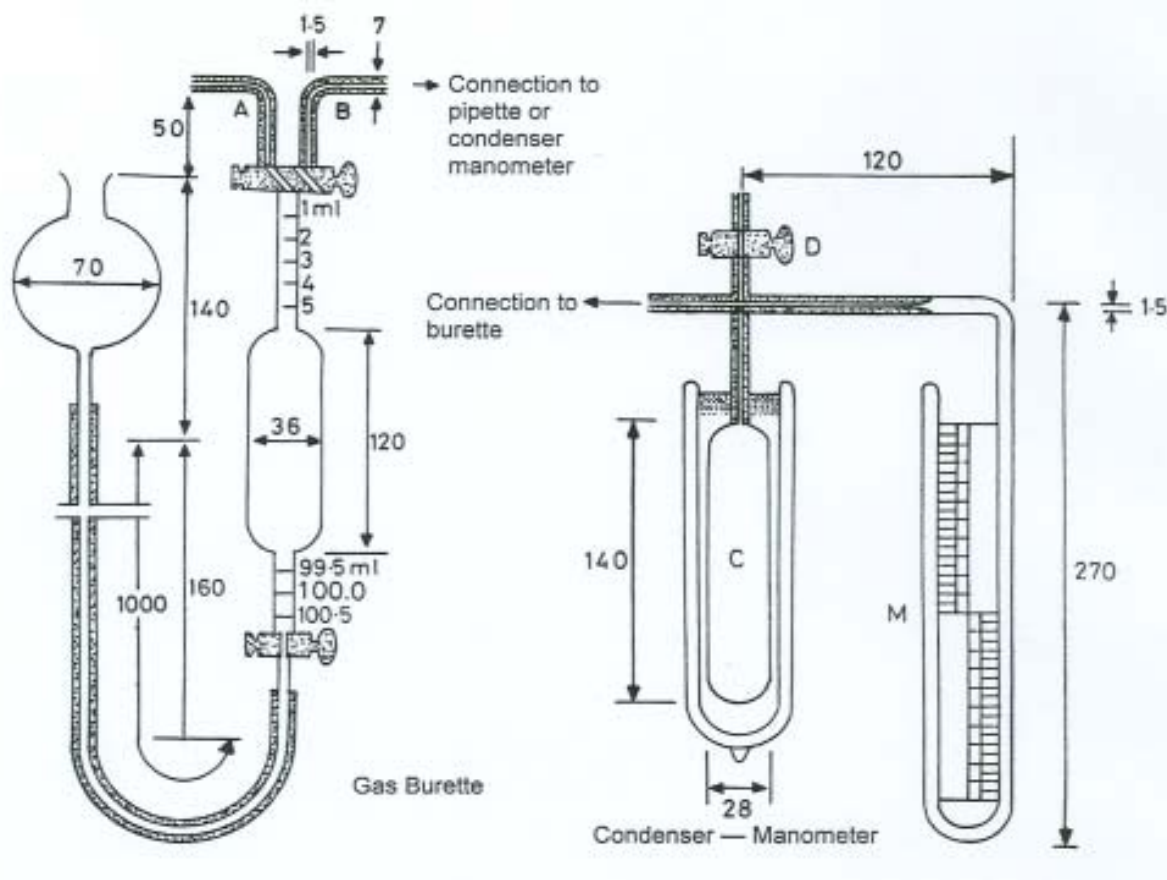

(Dimensions in mm unless otherwise stated)

Fig 2.3.32-1: Apparatus for Assay of Nitrous Oxide

### Method

Weigh accurately about 0.5 g in the case of a sulphonamide or otherwise the quantity specified in the individual monograph and transfer to the titration vessel. Add 20 ml of *hydrochloric acid* and 50 ml of *water* stir until dissolved, cool to about 15°. Immerse the platinum electrodes in the solution and apply a voltage of about 50 mV across the electrodes when polarisation of the electrodes takes place. Place the burette tip just above the surface of the solution and stir the solution gently, maintaining the temperature at about 15°. The titration may be carried out manually or by means of an automatic titrator. In the manual titration, add 0.1 M *sodium nitrite* slowly and when the titration is within 1 ml of the end point, add the titrant in 0.1 ml portions, allowing not less than 1 minute between additions. (The galvanometer needle deflects and then returns to approximately its original position until the end point is reached). At the end-point, when a slight excess of sodium nitrite is present, the electrodes are depolarised, current flows and a permanent deflection of the needle is obtained.

*NOTE*—It will be necessary to adjust the sensitivity of the galvanometer or the applied voltage before the titration is begun in order to obtain an adequate deflection at the end-point.

### 2.3.32 Assay of Nitrous Oxide

#### Apparatus

The apparatus shown in Fig 2.3.32-1 comprises a gas burette of 100-ml capacity, connected through a two-way tap at its upper end to two capillaries, one of which (A) is used to introduce the gas into the apparatus, the other (B) being connected to a vertical capillary arm to form a four-way junction. The descending arm of the junction is connected to a condenser (C) of about 60-ml capacity, and the right arm of the junction is connected to a mercury manometer (M). Tap D on the upper vertical arm of the junction opens to the air. The lower part of the gas burette is fitted with a one-way tap connected by a rubber tube to a mercury reservoir. The upper

part of the burette is graduated from 0 to 5 ml, and the lower part from 99.5 to 100.5 ml, both in increments of 0.1 ml.

### Method

Close the three taps and immerse the condenser in liquid nitrogen, keeping the level slightly above the upper part of the condenser. By manipulating the two-way tap and the mobile reservoir create a partial vacuum in the apparatus, choosing an arbitrary pressure,  $P_o$ , between 6.7 and 8 kPa (50 to 60 torr), accurately measured. This pressure must remain constant for 10 minutes to demonstrate that the apparatus is gas-tight.

Open the two-way tap to tube A and completely fill the burette and tube A with mercury. Close the two-way tap. Connect a rubber tube through a suitable pressure-relieving device to the exit valve of the cylinder of the gas under examination and pass a current of the gas through the rubber tube for 1 minute. Whilst the gas is still flowing, connect the rubber tube to the end of tube A and immediately open the two-way tap to tube A. Allow the specified volume of the gas to enter the burette by lowering the mercury reservoir. Disconnect the rubber tube and expel the gas from the burette by slowly raising the mercury reservoir above the capillary tube. Allow the specified quantity of the gas under examination to enter the burette by lowering the mercury reservoir and ensure that the pressure of the gas is equal to atmospheric pressure. Close the two-way tap.

Raise the mercury reservoir slightly above tube A and lower the level of the liquid nitrogen to the middle of the condenser. Carefully open the tap of the burette to connect with the condenser and allow the mercury to rise in the burette until it reaches the tap. Close the tap. Raise the level of the liquid nitrogen so as to totally immerse the condenser. Read the pressure and wait until it remains steady for 2 minutes.

Place the mercury reservoir in its bottom position and open the tap of the burette to make connection with the condenser. Move the mercury reservoir until the manometer reading is the same as the initial pressure  $P_o$ . Close the tap of the burette and, by means of the mercury reservoir, bring the pressure of the gas in the burette to atmospheric pressure. The number of ml of gas represents the non-condensable volume in the specified volume used.

After each series of 10 determinations allow atmospheric air to enter by opening the tap D, remove the liquid nitrogen from the condenser and allow the condenser to warm to room temperature.

### 2.3.33 Assay of Oxygen

#### Apparatus

The apparatus shown in Fig 2.3.33-1 comprises a gas burette of the type described under assay of nitrous oxide (Fig 2.3.32-

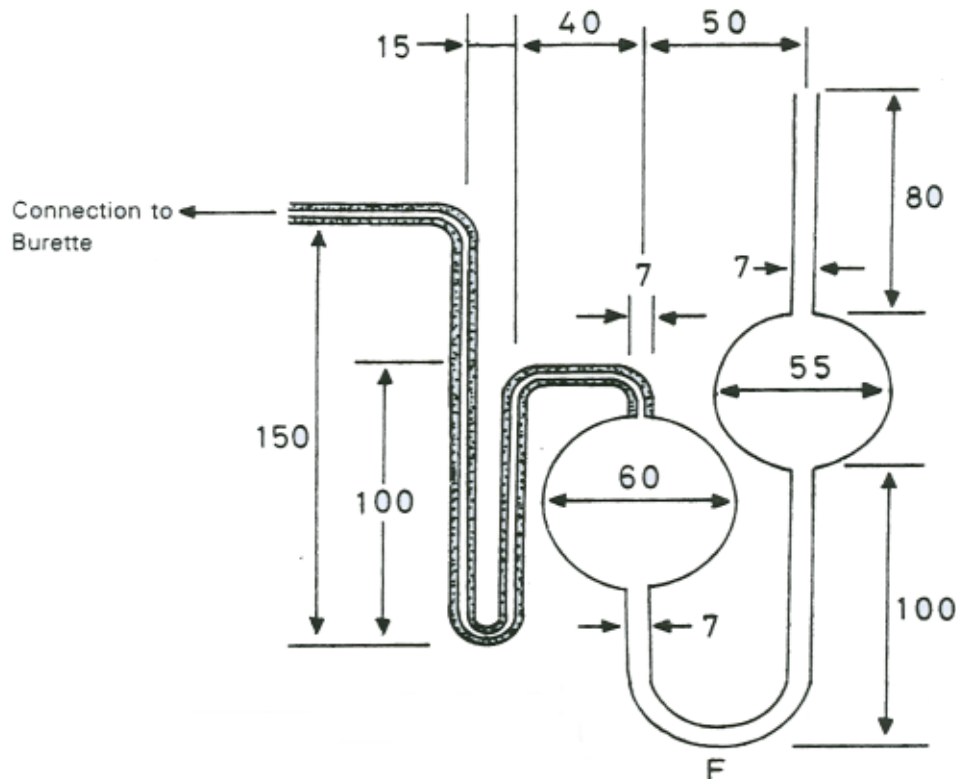

(Dimensions in mm unless otherwise stated)

Fig 2.3.33-1: Apparatus for Assay of Oxygen

1) in which tube B is connected to a gas pipette comprising two bulbs of suitable size.

### Method

Charge the pipette with the reagents specified in the monograph. With the two-way tap open to tube B, draw the solution just to the level of the tap by moving the mercury reservoir. Open the two-way tap to tube A, completely fill the burette and tube A with mercury and close the two-way tap. Connect a rubber tube to the exit valve of the cylinder of the gas under examination through a suitable pressure reducing device and pass a current of the gas through the tube for 1 minute.

Whilst the gas is still flowing, connect the rubber tube to tube A, immediately open the two-way tap to tube A, allow the specified quantity of the gas to enter the burette by lowering the mercury reservoir and close the two-way tap. Increase the pressure of the gas by raising the mercury reservoir, open the two-way tap to tube B and transfer all the gas to the pipette. Close the tap and gently shake the pipette. After 15 minutes, when most of the gas has been absorbed by the liquid, draw the residual gas back into the burette and repeat the procedure beginning at the words "Increase the pressure of the gas.." until the volume of residual gas is constant. Measure the volume of the residual gas in the burette.

## 2.3.34 Oxygen-Flask Method

*NOTE* — Great care must be taken in carrying out the following method. It is advisable to wear safety glasses and to use a suitable safety screen particularly when combustion takes place.

### Apparatus

The apparatus consists of a thick-walled, conical 500-ml iodine flask, fitted with a ground-glass stopper to which is fused a piece of platinum wire about 13 cm long and 1 mm in diameter and to which is attached a piece of platinum gauze to serve as means of holding the sample. The gauze may be about 2 cm wide and 1.5 cm long and should comply with the dimensions of a sieve with a nominal mesh aperture of 425  $\mu\text{m}$  (No. 36 sieve). The flask must be well-cleaned and free from even traces of organic solvents.

### Method

Solid substances should be finely ground and thoroughly mixed before the specified quantity is weighed.

For liquids place the specified quantity on about 15 mg of ashless filter-paper flock contained in one part of a methylcellulose capsule of a suitable size, close the capsule, inserting one end of a narrow strip of filter-paper between the two parts, and secure the capsule in the platinum gauze.

Ointments should be enclosed in grease-proof paper before wrapping in filter-paper.

Weigh accurately a suitable quantity of the substance under examination and wrap, if a solid, in a piece of halide-free filter-paper (4 cm  $\times$  3 cm), secure the package in the platinum gauze sample holder and insert one end of a narrow strip (1 cm  $\times$  3 cm) of filter-paper in the roll to serve as a fuse. Flush the flask with *oxygen*, moisten the neck with *water*, place the specified absorbing liquid in the flask, fill it with *oxygen* by swirling the liquid to favour its taking up the oxygen, light the free end of the fuse-strip and immediately insert the stopper. Hold the stopper firmly in place when vigorous burning has begun, invert the flask so as to provide a liquid seal but taking care to prevent incompletely burned material falling into the liquid. When combustion is complete, shake the flask vigorously for about 5 minutes, place a few ml of *water* in the cup top, carefully remove the stopper, and rinse the stopper, platinum wire, platinum gauze, and sides of the flask with *water*. Proceed as directed in the following methods.

### For Bromine

Burn the specified quantity of the substance under examination in the prescribed manner using 15 ml of a mixture of 9 volumes of 0.5 M sulphuric acid and 1 volume hydrogen peroxide solution (100 vol) as the absorbing liquid. When the process is complete, cool in ice for 15 minutes, add 5 ml of 2M nitric acid and 10 ml of 0.1 M silver nitrate and titrate with 0.05 M ammonium thiocyanate using ferric ammonium sulphate solution as indicator and shaking vigorously as the end-point is approached. Repeat the operation without the substance under examination; the difference between the titrations represents the number of ml of 0.05 M silver nitrate required. 1 ml of 0.05 M silver nitrate is equivalent to 0.003995 g of Br.

### For Chlorine

Burn the specified quantity of the substance under examination in the prescribed manner using 20 ml of 1 M sodium hydroxide as the absorbing liquid. When the process is complete, add 2.5 ml of nitric acid, 2.5 ml of water and 10 ml of 0.1 M silver nitrate and titrate with 0.05 M ammonium thiocyanate using ferric ammonium sulphate solution as indicator and shaking vigorously as the end-point is approached. Repeat the operation without the substance under examination; the difference between the titrations represents the number of ml of 0.05 M silver nitrate required. 1 ml of 0.05 M silver nitrate is equivalent to 0.001773 g of Cl.

### For Fluorine

Burn the specified quantity of the substance under examination in the prescribed manner using 20 ml of water as the absorbing liquid. When the process is complete, add sufficient water to

produce 100.0 ml. To 2.0 ml of this solution add 50 ml of *water*, 10 ml of *alizerine fluorine blue solution*, 3 ml of a solution containing 12 per cent w/v of *sodium acetate* and 6 per cent v/v of *glacial acetic acid*, 10 ml of *cerous nitrate solution* and sufficient *water* to produce 100.0 ml. Allow to stand in the dark for 1 hour and measure the *absorbance* of a 4-cm layer of the resulting solution at about 610 nm (2.4.7), using as the blank a solution prepared in the same manner but using 2.0 ml of *water* in place of the solution and beginning at the words "To 2.0 ml...". Calculate the flourine content from a reference curve prepared by treating suitable aliquots of a solution of *sodium fluoride* in the manner described above, beginning at the words "add 50 ml of *water*....".

#### For Iodine

Burn the specified quantity of the substance under examination in the prescribed manner using a mixture of 10 ml of *water* and 2 ml of 1 M *sodium hydroxide* as the absorbing liquid. When the process is complete, add an excess (5 to 10 ml) of *acetic bromine solution* and allow to stand for 2 minutes. Remove the excess of bromine by the addition of *formic acid* (5 to 10 ml), rinse the sides of the flask with *water* and sweep out any bromine vapour above the liquid with a current of air. Add 1 g of *potassium iodide* and titrate with 0.02 M *sodium thiosulphate* using *starch solution*, added towards the end of the titration, as indicator.

1 ml of 0.02 M *sodium thiosulphate* is equivalent to 0.000423 g of I.

#### For Sulphur

**Method I** (*in the absence of halogens and phosphorus*) — Burn the specified quantity of the substance under examination in the prescribed manner using 10 ml of *water* and 0.1 ml *hydrogen peroxide solution (100 vol)* as the absorbing liquid. When the process is complete, cool the solution in ice for about 15 minutes. Gently boil for 2 minutes, cool and add 50 ml of *ethanolic acetic-ammonia buffer pH 3.7*. Titrate with 0.05 M *barium perchlorate* using 0.3 ml of *alizerin red S solution* as indicator, until the solution becomes orange-pink in colour.

1 ml of 0.05 M *barium perchlorate* is equivalent to 0.001603 g of S.

**Method II** (*in the presence of halogens or phosphorus*) — Burn the specified quantity of the substance under examination in the prescribed manner using 15 ml of *water* and 1 ml of *hydrogen peroxide solution (20 vol)* as the absorbing liquid. When the process is complete, boil the solution for 10 minutes, cool and add 60 ml of *ethanol (95 per cent)*. Titrate the solution with 0.01 M *barium perchlorate*, using a 0.1 ml of 0.2 per cent w/v solution of *thoron* and 0.1 ml of a 0.0125 per cent w/v solution of *methylene blue* as indicator, until the yellow colour changes to pink.

1 ml of 0.01 M *barium perchlorate* is equivalent to 0.0003206 g of S.

If the temperature at which the determinations prescribed under Method I and II are performed differs from that at which the barium perchlorate solution was standardised, the titrant volumes are corrected by applying the expression

$$V_c = V[1 + 0.0008(t_1 - t_2)]$$

where,  $V_c$  = the corrected volume of titrant,  
 $V$  = the volume of titrant used,  
 $t_1$  = the temperature of the titrant during standardisation,  
 $t_2$  = the temperature of the titrant during the determination.

### 2.3.35. Peroxide Value

The peroxide value is the number of milliequivalents of active oxygen that expresses the amount of peroxide contained in 1000 g of the substance.

#### Method

Unless otherwise specified in the individual monograph, weigh accurately about 5 g of the substance under examination, transfer to a 250-ml glass-stoppered conical flask, add 30 ml of a mixture of 3 volumes of *glacial acetic acid* and 2 volumes of *chloroform*, swirl until dissolved and add 0.5 ml of *saturated potassium iodide solution*. Allow to stand for exactly 1 minute, with occasional shaking, add 30 ml of *water* and titrate gradually, with continuous and vigorous shaking, with 0.01 M *sodium thiosulphate* until the yellow colour almost disappears. Add 0.5 ml of *starch solution* and continue the titration, shaking vigorously until the blue colour just disappears ( $a$  ml). Perform a blank determination omitting the substance under examination ( $b$  ml). The volume of 0.01 M *sodium thiosulphate* in the blank determination must not exceed 0.1 ml.

Calculate the peroxide value from the expression

$$\text{Peroxide value} = 10(a - b)/w$$

Where,  $w$  = weight, in g, of the substance.

### 3.3.36. Phenol in Vaccines and Antisera

Homogenise the preparation under examination. Dilute an appropriate volume with *water* to give a solution containing about 15 µg of phenol per ml. To 5.0 ml of the resulting solution add 5 ml each of *buffer solution pH 9.0*, *4-aminophenazone solution* and *potassium ferricyanide solution*. Allow to stand for 10 minutes and measure the absorbance of the resulting solution at about 546 nm (2.4.7). Calculate the phenol content from the absorbance obtained, using a calibration curve



prepared by repeating the operation using 5 ml of each of a series of solutions containing 5 µg, 10 µg, 15 µg, 20 µg and 30 µg of *phenol* per ml respectively.

### 2.3.37. Saponification Value

The saponification value is the number of milligrams of potassium hydroxide necessary to neutralise the free acids and to saponify the esters present in 1 g of the substance.

#### Method

Unless otherwise specified in the individual monograph, introduce about 2 g of the substance under examination, accurately weighed, into a 200-ml flask of borosilicate glass fitted with a reflux condenser. Add 25.0 ml of 0.5 M *ethanolic potassium hydroxide* and a little *pumice powder* and boil under reflux on a water-bath for 30 minutes. Add 1 ml of *phenolphthalein solution* and titrate immediately with 0.5 M *hydrochloric acid* (*a* ml). Perform a blank determination omitting the substance under examination (*b* ml). Calculate the saponification value from the expression

$$\text{Saponification value} = 28.05 (b - a)/w$$

where, *w* = weight, in g, of the substance.

*NOTE* — If the oil has been saturated with carbon dioxide for the purpose of preservation, gently reflux the solution of the oil in ethanol (95 per cent) and ether for 10 minutes before titration. The oil may be freed from the carbon dioxide by exposing it in a shallow dish in a vacuum desiccator for 24 hours before weighing the sample.

### 2.3.38. Assay of Steroids

*Test solution.* Prepare as directed in the individual monograph.

*Standard solution.* Weigh accurately a suitable quantity of the reference substance specified in the individual monograph, previously dried under the conditions specified in the monograph, and dissolve in a suitable volume of *aldehyde-free ethanol*. Dilute quantitatively and stepwise with *aldehyde-free ethanol* to obtain a solution containing about 10 µg of the steroid per ml.

#### Method

Into a glass-stoppered, 50-ml conical flask add 20.0 ml of the test solution. Into two similar flasks add 20.0 ml of the standard solution and 20.0 ml of *aldehyde-free ethanol* (blank), respectively. To each flask add 2.0 ml of *blue tetrazolium solution* and mix; to each flask add 2.0 ml of a mixture of *tetramethylammonium hydroxide solution* (10 per cent) and 90 volumes of *aldehyde-free ethanol*, mix and allow to stand in the dark at a temperature between 25° and 35°. At the end of

exactly 90 minutes add to each flask 1.0 ml of *glacial acetic acid* and mix. Measure the absorbances of the solutions obtained from the test solution and the standard solution at about 525 nm against the blank (2.4.7).

Calculate the quantity, in mg, of the steroid in the 20-ml aliquot of the test solution from the expression

$A_t/A_s \times C_s$  where,  $A_t$  is the absorbance of the test solution,  $A_s$  is the absorbance of the standard solution and  $C_s$  is the quantity, in mg, of the reference substance in the 20-ml aliquot of the standard solution.

Calculate the quantity of the steroid in the substance under examination on the basis of the aliquot of the test solution taken for the assay and from the declared content of the steroid in the appropriate reference substance.

### 2.3.39. Unsaponifiable Matter

The unsaponifiable matter consists of substances present in oils and fats which are not saponifiable by alkali hydroxides and are determined by extraction with an organic solvent of a solution of the saponified substance under examination.

#### Method

Unless otherwise specified in the individual monograph, introduce about 5 g of the substance under examination, accurately weighed, into a 250-ml flask fitted with a reflux condenser. Add a solution of 2 g of *potassium hydroxide* in 40 ml of *ethanol* (95 per cent) and heat on a water bath for 1 hour, shaking frequently. Transfer the contents of the flask to a separating funnel with the aid of 100 ml of hot *water* and, while the liquid is still warm, shake very carefully with three quantities, each of 100 ml, of *peroxide-free ether*. Combine the ether extracts in a second separating funnel containing 40 ml of *water*, swirl gently for a few minutes, allow to separate and reject the lower layer. Wash the extract with two quantities each of 40 ml, of *water* and with three quantities, each of 40 ml, of a 3 per cent w/v solution of *potassium hydroxide*, each treatment being followed by a washing with 40 ml of *water*. Finally, wash the ether layer with successive quantities, each of 40 ml, of *water* until the aqueous layer is not alkaline to *phenolphthalein solution*. Transfer the ether layer to a weighed flask, washing out the separating funnel with *peroxide-free ether*. Distill off the ether and add to the residue 6 ml of *acetone*. Remove the solvent completely from the flask with the aid of a gentle current of air. Dry at 100° to 105° for 30 minutes. Cool in a desiccator and weigh the residue. Calculate the unsaponifiable matter as per cent w/w.

Dissolve the residue in 20 ml of *ethanol* (95 per cent), previously neutralised to *phenolphthalein solution* and titrate with 0.1 M *ethanolic potassium hydroxide*. If the volume of 0.1 M *ethanolic potassium hydroxide* exceeds 0.2 ml, the



amount weighed cannot be taken as the unsaponifiable matter and the test must be repeated.

### 2.3.40. Sulphur Dioxide

Use Method A unless otherwise directed.

#### Method A

##### Apparatus

A round-bottomed flask of 1000 to 1500 ml capacity is connected with a water-cooled reflux condenser whose upper end is connected with two absorption tubes in series. The flask is provided with a gas inlet tube which reaches nearly to the bottom of the flask. Each absorption tube contains 10 ml of *hydrogen peroxide solution (20 vol)* neutralised with *0.1 M sodium hydroxide* using *bromophenol blue solution* as indicator.

##### Procedure

Place in the flask 500 ml of *water* and 20 ml of *hydrochloric acid*. Connect the flask with the condenser and absorption tubes, pass through it a steady current of *nitrogen* or *carbon dioxide* which has been bubbled through *sodium carbonate solution* and gradually heat the liquid until it boils. Maintain the current of *nitrogen* or *carbon dioxide*, allow the solution to boil for about 10 minutes and then cool the flask by gradual immersion in water. Introduce, by momentarily removing the stopper of the flask, 50 to 100 g of the substance under examination, heat gently and boil for 45 minutes. Turn off the current of *nitrogen* or *carbon dioxide*, disconnect the absorption tubes and titrate the contents with *0.1 M sodium hydroxide*.

1 ml of *0.1 M sodium hydroxide* is equivalent to 0.003203 g of  $\text{SO}_2$ .

Repeat the operation without the substance under examination; the solution in the absorption tubes remains neutral.

#### Method B

##### Apparatus

A 500-ml three-necked round-bottomed flask is fitted with a water-cooled reflux condenser, 200 mm long, the upper end of which is connected to an absorption tube. The flask is fitted with a 100-ml dropping funnel and a gas inlet tube which reaches nearly to the bottom of the flask. The absorption tube contains 10 ml of *hydrogen peroxide solution (10 vol)* previously neutralised to *bromophenol blue solution*.

##### Procedure

Place 150 ml of *water* in the flask and pass a stream of *carbon dioxide* at a rate of 100 ml per minute for 15 minutes. Connect

the absorption tube and without interrupting the flow of *carbon dioxide* introduce through the funnel the prescribed quantity of the substance under examination and 80 ml of *2 M hydrochloric acid*. Boil for 1 hour, disconnect the absorption tube and stop the flow of *carbon dioxide*. Wash the contents of the absorption tube into a 250-ml conical flask, heat on a water-bath for 15 minutes and allow to cool. Titrate with *0.1 M sodium hydroxide* using *bromophenol blue solution* as indicator until the colour changes from yellow to violet-blue.

1 ml of *0.1 M sodium hydroxide* is equivalent to 0.003203 g of  $\text{SO}_2$ .

### 2.3.41. Assay of Vitamin A

The following methods for the determination of the potency of vitamin A in pharmacopoeial preparations are based on the measurement of the ultra-violet spectrum of the vitamin at the specified wavelength. The potency of vitamin A is expressed in terms of the Unit, which is  $0.344 \mu\text{g}$  of *all-trans-vitamin A acetate*, equivalent to  $0.3 \mu\text{g}$  of *all-trans-vitamin A alcohol*.

A simple measurement of the absorption maximum is not sufficient because in addition to vitamin A, other substances may contribute to the measured absorbance. The irrelevant absorption of such substances may be taken care of under certain conditions (given below) by the use of correcting equations. In other cases, where these conditions are not satisfied, preliminary treatment by chemical or physical methods or by a combination of these methods may be necessary before the following spectrophotometric methods are used to give a valid assay.

The assay should be carried out as speedily as possible and care must be taken to avoid exposure to actinic light and oxidising agents and to maintain to the extent possible an atmosphere of nitrogen above the solutions.

Since the position of the absorption maximum is an important criterion and since the correcting equations require measurements at exact wavelengths, it is essential that the wavelength scale of the spectrophotometer is checked immediately before the assay (2.4.7). The mercury lines at 313.16 nm and 334.15 nm provide suitable points and for convenience the setting of the instrument on these lines may be related to its setting on the hydrogen lines at 379.7 nm and 496.1 nm. The precision of a corrected absorbance is appreciably less than that of the three directly determined absorbances from which it is calculated. The absorbance measurements therefore require special care and not fewer than two assays should be performed.

#### Method A

This method is suitable for preparations which contain vitamin A as an ester and in a form directly soluble in *cyclohexane*.

**Procedure**

Dissolve an accurately weighed quantity of the substance under examination in sufficient *cyclohexane* to give a solution containing 9 to 15 Units of vitamin A per ml. Determine the wavelength of maximum absorption. Measure the absorbances (2.4.7) of the solution against the *cyclohexane* at the wavelength given in Table 1. Calculate the absorbances at the wavelengths specified, as fractions relative to that at 328 nm. Calculate also the absorbance at 328 nm in terms of specific absorbance for the sample.

If the wavelength of maximum absorption lies between 326 and 329 nm and the relative absorbances are within 0.02 of those in Table 1, calculate the vitamin A potency of the sample from the expression

$A_{328}(1 \text{ per cent, } 1 \text{ cm}) \times 1900 = \text{Vitamin A potency in Units per g.}$

Table 1

Wavelength (nm)	Relative absorbance
300	0.555
316	0.907
328	1.000
340	0.811
360	0.299

If the wavelength of maximum absorption lies between 326 nm and 329 nm but the relative absorbances are not within 0.02 of those in the table, calculate a corrected absorbance at 328 nm by applying the observed values to the equation

$$A_{328}(\text{corr.}) = 3.52(2A_{328} - A_{316} - A_{340}).$$

If the corrected absorbance lies within  $\pm 3.0$  per cent of the uncorrected absorbance, ignore the corrected absorbance and calculate the potency from the uncorrected absorbance.

If the corrected absorbance lies within  $-15$  per cent and  $-3$  per cent of the uncorrected absorbance, calculate the potency from the corrected absorbance.

If the corrected absorbance lies outside  $-15$  per cent to  $+3$  per cent of the uncorrected absorbance or if the wavelength of maximum absorption does not lie between 326 nm and 329 nm, the substance under examination must be dealt with as described under Method B.

**Method B****Special Reagents****All-trans-Vitamin A Acetate**

**Description.** A white to very yellow, free flowing crystals.

**Solubility.** Very soluble in *ethanol* (95 per cent) in *chloroform*, in *ether*, in *light petroleum*, in fats and in fixed oils; practically insoluble in *water*.

**Light absorption.** Absorbance of a 0.0003 per cent w/v solution in *2-propanol* at about 325 nm, not less than 0.458, in *cyclohexane* at about 327.5, not less than 0.455 and in *ethanol* at about 326 nm, not less than 0.464 (2.4.7).

**Melting range.** 57° to 60° (2.4.21).

**Relative absorbance.** Measure the absorbance (2.4.7), of a 0.0003 per cent w/v solution *cyclohexane* at about 327.5 nm and at the following wavelengths. The relative absorbances, calculated with reference to the absorbance at about 327.5 nm, are within the limits stated in Table 2.

Table 2

Wavelength (nm)	Relative absorbance
300	0.545 to 0.565
312.5	0.845 to 0.865
337.5	0.845 to 0.865
345	0.685 to 0.705
360	0.290 to 0.310

**Procedure**

Weigh accurately a quantity of the substance under examination containing not less than 500 Units of vitamin A and not more than 1 g of fat. Add about 50 mg of *hydroquinone*, 30 ml of *ethanol* and 3 ml of a 50 per cent w/v solution of *potassium hydroxide*. Boil gently under a reflux condenser in a stream of *oxygen-free nitrogen* for 30 minutes, cool rapidly and add 30 ml of *water*. Transfer to a separator with the aid of three quantities, each of 50 ml, of *ether* and extract the vitamin A by shaking for 1 minute. After complete separation discard the aqueous layer and wash the extract with four quantities, each of 50 ml, of *water*, mixing very cautiously during the first two washes to avoid the formation of emulsions. Evaporate the separated extract to about 5 ml and remove the remaining solvent in a stream of *oxygen-free nitrogen* without the application of heat. Dissolve the residue in sufficient *2-propanol* to produce a solution containing 9 to 15 Units of vitamin A per ml and measure the absorbance at about 300, 310, 325 and 334 nm. Determine the wavelength of maximum absorption.

If the wavelength of maximum absorption lies between 323 nm and 327 nm and the absorbance at about 300 nm relative to that at about 325 nm does not exceed 0.73, a corrected absorbance is derived from the equation

$$A_{325}(\text{corr.}) = 6.815A_{325} - 2.555A_{310} - 4.260A_{334}.$$

Calculate the potency of the sample from the expression

$$A_{325}(1 \text{ per cent, } 1 \text{ cm}) \times 1830 = \text{Vitamin A potency in Units per g.}$$

If the corrected absorbance lies within  $\pm 3.0$  per cent of the uncorrected absorbance, ignore the corrected absorbance and calculate the potency from the uncorrected absorbance.

If the wavelength of maximum absorption lies outside the range 323 nm to 327 nm, or if the relative absorbance at about 300 nm exceeds 0.73, the unsaponifiable fraction of the sample must be further purified by chromatography.

### 2.3.42. Assay of Vitamin D

The assay should be completed promptly and care should be taken throughout the procedure to keep to a minimum the exposure to air and to actinic light by the use of inert gas and low actinic glassware. All the operations should be carried out in subdued light.

#### Special Reagents

**Adsorbent:** A chromatographic grade of kaolin such as Florex XXS or of fuller's earth having a water content corresponding to not less than 8.5 per cent and not more than 9.0 per cent of loss on drying at 105° for 6 hours.

*NOTE* — Adjust the water content, if necessary, by drying in vacuo at room temperature, restoring the water required and equilibrating by shaking for 2 hours.

**Standard preparation of vitamin D.** Dissolve 0.01 g of *ergocalciferol RS* or *cholecalciferol RS* (for assaying substances labelled to contain Vitamin D as ergocalciferol or as cholecalciferol respectively) in sufficient *purified 1,2-dichloroethane* to produce 100.0 ml. Dilute 10.0 ml of this solution to 100.0 ml with *purified 1,2-dichloroethane* to give a solution containing 10 µg (400 Units) of vitamin D per ml.

#### Apparatus

##### Chromatographic Tubes

**Column No. 1.** A chromatographic tube (25 cm × 2.5 mm) fitted at the lower end with a sintered glass disc or a small plug of glass wool and a tap.

**Column No. 2.** A chromatographic tube (20 cm × 5 mm) fitted at the lower end with a sintered glass disc and a tap.

##### Chromatographic columns

**Column No. 1.** Shake 200 ml of 2,2,4-trimethylpentane with sufficient *polyethylene glycol 600* so that, on separation, two layers are obtained. To 100 ml of the upper layer add 25 g of *chromatographic siliceous earth*, shake vigorously to form a thin slurry, add, in small portions and with vigorous stirring,

10 ml of *polyethylene glycol 600* and continue to stir for a further 2 minutes to produce a uniform suspension. Transfer the suspension in small portions to the chromatographic tube, apply gentle suction and pack each portion carefully with the aid of a glass plunger. Add sufficient of the suspension to produce a column 15 cm in length and discard any eluate.

*Standardisation of column* — Determine the volume in which ergocalciferol is recovered from the column by the following method.

Transfer 2 ml of a 0.03 per cent w/v solution of *ergocalciferol* in 2,2,4-trimethylpentane to the top of the column and rinse it into the column with not more than 5 ml of *trimethylpentane*. Elute the column with 2,2,4-trimethylpentane, adjusting the rate of flow from the bottom of the column to 2 to 3 ml per minute and collect successive 5 ml fractions of the eluate. Measure the absorbance of each fraction at the maximum at about 263 nm and therefrom determine the position, relative to volume of eluate, at which the elution of ergocalciferol begins and finishes.

**Column No. 2.** Mix 5 g of *adsorbent* with sufficient 2,2,4-trimethylpentane to form a slurry and transfer the slurry to the chromatograph tube. Pack the tube carefully with the aid of glass plunger and discard the eluate.

#### Procedure

Weigh accurately a quantity of the substance under examination equivalent to about 400 Units of vitamin D. For capsules, the mixed contents of 20 capsules may be used as the sample. Add 10 ml of a freshly prepared 0.01 per cent w/v solution of *butylated hydroxytoluene* in *ethanol (95 per cent)*, 15 ml of a 50 per cent w/v solution of *potassium hydroxide* and 5 ml of *ethanol (95 per cent)*. Reflux on a water-bath for 30 minutes, cool, transfer the solution to a separator with the aid of 50 ml of *water*, add 75 ml *ether* and shake vigorously. Allow to separate, transfer the aqueous layer to a second separator and extract with three successive quantities, each of 30 ml, of *ether*, adding each ethereal extract to the liquid in the first separator and finally discarding the aqueous solution.

Pour two successive quantities, each of 100 ml, of *water* through the ethereal solution without shaking and discard the aqueous layers. Add successive quantities, each of 10 ml, of *water* to the ethereal solution, agitate gently each time and discard the aqueous extracts. Continue the process until the aqueous extracts are neutral to *phenolphthalein solution*.

Dry the ethereal solution by stirring with *anhydrous sodium sulphate*, decant the ethereal solution, wash the residue with successive small portions of *ether* and evaporate the combined solution and washings on a water-bath to a volume of about 5 ml. Cool and evaporate to dryness in a current of *nitrogen*. Dissolve the residue in 5.0 ml of *trimethylpentane* to obtain the sample preparation.

Transfer the sample preparation to the top of chromatographic column No. 1 with the aid of 5 ml of *2,2,4-trimethylpentane*, elute the column with *2,2,4-trimethylpentane*, adjusting the rate of flow of eluate from the bottom of the column to 2 to 3 ml per minute, and collect the fraction of eluate estimated to contain the calciferol, as indicated by the standardisation of the column.

Transfer the eluate collected from chromatographic column No. 1 to the top of chromatographic column No. 2, allow the liquid to flow, add to the top of the column 10 ml of *trimethylpentane* and discard the eluate. Elute the column with 50 ml of *benzene*, evaporate the eluate on a water-bath to a volume of about 5 ml, cool, evaporate to dryness in a current of *nitrogen* and dissolve the residue in 4.0 ml of *purified 1,2-dichloroethane* to obtain the sample solution (solution A).

Add 1.0 ml of solution A to each of three tubes. To the first tube add 1.0 ml of a mixture of equal volumes of *purified 1,2-dichloroethane* and *acetic anhydride* and 10.0 ml of *antimony trichloride solution* in *purified 1,2-dichloroethane*. To the second tube add 1.0 ml of *purified 1,2-dichloroethane* and 10.0 ml of *antimony trichloride solution* in *purified 1,2-dichloroethane*. To the third tube add 1.0 ml of the *standard preparation of vitamin D* and 10.0 ml of *antimony trichloride solution* in *purified 1,2-dichloroethane*.

Measure the absorbance of each solution exactly 1 minute after the addition of the antimony trichloride solution at the maximum at about 500 nm using *purified 1,2-dichloroethane* as the blank (2.4.7). The amount of vitamin D, in mg, in the weight of the sample taken is given by the expression

$$\frac{0.04(A_1 - A_2)}{(A_3 - A_2)}$$

where,  $A_1$  = the absorbance due to the solution in the first tube;

$A_2$  = the absorbance due to the solution in the second tube;

$A_3$  = the absorbance due to the solution in the third tube.

1 mg of ergocalciferol or cholecalciferol is equivalent to 40,000 Units of vitamin D.

### 2.3.43. Water

#### Method 1. Titrimetric Method

##### Apparatus

A titration vessel of about 60 ml capacity fitted with two platinum electrodes, about 0.05 sq. cm in area and about 2.5 cm apart a nitrogen inlet tube, a stopper which accommodates the burette tip and a vent tube protected by a suitable desiccant

such as *phosphorous pentoxide* or *silica gel*. The substance under examination is introduced through an inlet or side arm that can be closed by a ground stopper. Stirring is done magnetically or by means of a stream of dried *nitrogen* passed through the solution during the titration. The air in the entire system should be kept dry during the titration.

The end-point is determined by amperometry. The circuit consists of a potentiometer of about 2000 ohms connected across a 1.5 V battery. The resistance is adjusted so that an initial low current passes through the electrodes. On adding the reagent the needle of the microammeter shows a deflection but returns immediately to its starting position. At the end point of the titration a slight excess of the reagent produces a deflection that persists for not less than half a minute.

**Karl Fischer (KF) reagent.** The reagents and solutions used for preparing the KF reagent should be kept anhydrous and care should be taken throughout the determination to prevent exposure to atmospheric moisture. The reagent should be protected from light and stored in a bottle to which is fitted an automatic burette.

**Primary standardisation of the reagent.** Place about 36 ml of *dehydrated methanol* in the titration vessel and add sufficient *KF reagent* to give the characteristic end-point. Add quickly 150 to 350 mg of *sodium tartrate*,  $C_6H_4O_4Na_2 \cdot 2H_2O$ , accurately weighed by difference and titrate to the end-point. The water equivalence factor, F, in mg of water per ml of the reagent is given by the expression  $0.1566 w/v$ , where w is the weight, in mg of the sodium tartrate and v is the volume, in ml, of the reagent required.

**Secondary standardisation of the reagent.** The *KF reagent* may alternatively be standardised for each day's use against a water-methanol solution standardised as follows. Add 2.0 ml of *water* to 1000.0 ml of *dehydrated methanol*. Retain a portion of the methanol used for a blank determination. Place 25 ml, accurately measured of the water-methanol solution in the titration vessel and titrate with *KF reagent*. Perform a blank titration on 25 ml accurately measured, of the methanol used and make any necessary correction. The water content in mg per ml of the water-methanol solution is given by the expression  $VF/25$  in which V is the volume, in ml, of *KF reagent* required and F is the water equivalent factor of the reagent determined against *sodium tartrate* as directed under Primary standardisation of the reagent.

Follow Method A unless otherwise directed.

**Method A.** Unless otherwise directed, add about 20 ml of *dehydrated methanol* to the titration vessel and titrate to the electrometric end point with the *KF reagent*. Transfer quickly the prescribed amount of the substance under examination, accurately weighed, to the titration vessel. Stir for 1 minute and titrate again to the electrometric end point using the *KF reagent*.



The water content of the sample, in mg is given by the expression  $SXF$ , in which  $S$  is the volume, in ml of the *KF reagent* used to titrate the sample and  $F$  is the water equivalent factor.

**Method B.** This method should be followed for samples that react with difficulty or too slowly for convenient direct titration with the *KF reagent*.

Unless otherwise directed add about 10 ml of *dehydrated methanol* to the titration vessel and titrate to the electrometric end point with the *KF reagent*. Transfer quickly the prescribed amount accurately weighed, of the substance under examination to the titration vessel followed by an accurately measured amount of *KF reagent* sufficient to give an excess of about 1 ml. Allow to stand, protected from light, for 1 minute, stirring well. Titrate the excess of the reagent to the electrometric end-point with *dehydrated methanol* to which has been added an accurately known amount of *water* equivalent to about 0.25 per cent w/v.

Calculate the content of water from the expression  $S \times F$ , where  $S$  is the volume, in ml, of the *KF reagent* used to titrate the sample and  $F$  is the equivalence factor.

Unless otherwise directed, express the result as a percentage w/w.

## Method 2. Azeotropic Distillation Method

### Apparatus

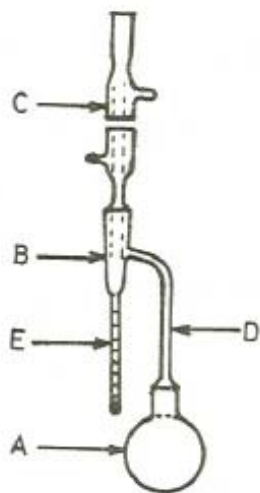

Fig. 2.3.43-1: Apparatus for Determination of water by Azeotropic Distillation

The apparatus (see figure) consists of a round-bottomed, 500-ml flask (A) connected by means of a trap (B), 23.5 to 24.0 cm long, to vertical reflux condenser of the straight tube type (C) by ground glass joints. The condenser is approx. 40 cm long and has a bore diameter of not less than 8 mm. The connecting tube (D) is 9 to 11 mm in internal diameter. The receiving tube

(E) has a 5 ml capacity and its cylindrical part, 14.6 to 15.6 cm in length, is graduated in 0.1 ml sub divisions. The flask is heated in an oil bath or in an electric mantle. The upper portion of the flask and the connecting tube may be insulated.

Before use, the condenser and receiving tube should be cleaned with *chromic acid mixture*, thoroughly rinsed with *water* and dried in an oven.

**Method.** Weigh accurately a quantity of the substance under examination, that is expected to yield 2 to 4 ml of water and transfer to the dry flask. If the substance is semi-solid, weigh it in a metal foil, fold the foil carefully and pass it through the neck of the flask. To prevent bumping, add enough washed and dried sand to cover the bottom of the flask or few capillary melting point tubes, 10 cm long, sealed at the upper end. Add about 200 ml of *prepared toluene*, connect the apparatus and fill the receiving tube (E) with *prepared toluene* poured through the top of the condenser. Heat the flask gently for 15 minutes and when the toluene begins to boil, distil at the rate of about 2 drops per second until most of the water has distilled over. Then increase the rate to about 4 drops per second. When the water has apparently completely distilled over, rinse the inside of the condenser tube with *prepared toluene* with the aid of a tube brush attached to a copper wire and saturated with *prepared toluene*. Continue distillation for 5 minutes, remove the heat and allow the receiving tube to cool to room temperature. If any droplets of water stick to the wall of the receiving tube, scrub them using a copper wire with a rubber band wrapped round it and washed with *prepared toluene*. After complete separation of the water and toluene in the tube, read off the volume of water in the tube and calculate the content of water as a percentage w/w, assuming the weight per ml of water to be 1.0.

## Method 3. Coulometric Titration

**Principle.** The coulometric titration of water is based upon the quantitative reaction of water with sulphur dioxide and iodine in an anhydrous medium in the presence of a base with sufficient buffering capacity. In contrast to the volumetric method described under Method 1, iodine is produced electrochemically in the reaction cell by oxidation of iodide. The iodine produced at the anode reacts immediately with the water and the sulphur dioxide contained in the reaction cell. The amount of water in the substance is directly proportional to the quantity of electricity up until the titration end-point. When all of the water in the cell has been consumed, the end-point is reached and thus an excess of iodine appears. 1 mole of iodine corresponds to 1 mole of water, a quantity of electricity of 10.71 C corresponds to 1 mg of water.

Moisture is eliminated from the system by pre-electrolysis. Individual determinations can be carried out successively in the same reagent solution, under the following conditions.



- each component of the test mixture is compatible with the other components,
- no other reactions take place,
- the volume and the water capacity of the electrolyte reagent are sufficient.

Coulometric titration is restricted to the quantitative determination of small amounts of water, a range of 10 µg up to 10 mg of water is recommended.

Accuracy and precision of the method are predominantly governed by the extent to which atmospheric moisture is excluded from the system. Control of the system must be monitored by measuring the amount of baseline drift.

**Apparatus.** The apparatus consists of a reaction cell, electrodes and magnetic stirrer. The reaction cell consists of a large anode compartment and a smaller cathode compartment. Depending on the design of the electrode, both compartments can be separated by a diaphragm. Each compartment contains a platinum electrode. Liquid or solubilised samples are introduced through a septum, using a syringe. Alternatively, an evaporation technique may be used in which the sample is heated in a tube (oven) and the water is evaporated and carried into the cell by means of a stream of dry inert gas. The introduction of solid samples into the cell should in general be avoided. However, if it has to be done it is effected through a sealable port; appropriate precautions must be taken to avoid the introduction of moisture from air, such as working in a glove box in an atmosphere of dry inert gas. The analytical procedure is controlled by a suitable electronic device, which also displays the results.

**Method.** Fill the compartments of the reaction cell with *electrolyte reagent for the determination of water* according to the manufacturer's instructions and perform the coulometric titration to a stable end-point. Introduce the prescribed amount of the substance under examination into the reaction cell, stir for 30 seconds, if not otherwise indicated in the monograph, and titrate again to a stable end-point. In case an oven is used, the prescribed sample amount is introduced into the tube and heated. After evaporation of the water from the sample into the titration cell, the titration is started. Read the value from the instrument's output and calculate if necessary the percentage or amount of water that is present in the substance. When appropriate to the type of sample and the sample preparation, perform a blank titration.

**Verification of the accuracy.** Between two successive sample titrations, introduce an accurately weighed amount of water in the same order of magnitude as the amount of water in the sample, either as *water* or in the form of *standard solution for the determination of water*, and perform the coulometric titration. The recovery rate is within the range from 97.5 per cent to 102.5 per cent for an addition of 1,000 µg of H<sub>2</sub>O and in

the range from 90.0 per cent to 110.0 per cent for the addition of 100 µg of H<sub>2</sub>O.

### 2.3.44. Zinc

*NOTE* — All reagents used in this test should have as low a content of heavy metals as practicable. All glassware should be rinsed with warm dilute nitric acid followed by water previously distilled in hard or borosilicate glass apparatus. Separators should not be greased with materials that dissolve in chloroform.

#### Method

Pipette 1 to 5 ml of the preparation under examination into a centrifuge tube graduated at 40 ml. If necessary, add 0.25 M hydrochloric acid dropwise, to obtain a clear solution. Add 5 ml of *trichloroacetic acid solution* and sufficient *water* to produce 40.0 ml. Mix well and centrifuge.

Pipette into a hard-glass separator a volume of the supernatant liquid equivalent to about 5 to 20 µg of zinc and add *water* to produce 20 ml. Add 1.5 ml of *alkaline ammonium citrate solution* and 35 ml of *dithizone standard solution*. Shake vigorously several times and allow the chloroform to separate. Collect the chloroform extract through a cotton plug placed in the stem of the separator and discard the first few ml. Measure the absorbance of the extract at about 530 nm (2.4.7), using as the blank an extract obtained by repeating the determination omitting the preparation under examination.

Calculate the amount of zinc by reference to standard graph obtained by using 0.5 ml, 1.0 ml, 1.5 ml and 2.0 ml of *zinc standard solution (10 ppm Zn)* and repeating the determination as outlined above.

### 2.3.45. Ethanol

The ethanol content of a liquid is expressed as the number of volumes of ethanol contained in 100 volumes of the liquid, the volumes being measured at 24.9° to 25.1°. This is known as the "percentage of ethanol by volume". The content may also be expressed in grams of ethanol per 100 g of the liquid. This is known as the "percentage of ethanol by weight".

Use Method I or Method II, as appropriate, unless otherwise specified in the individual monograph.

#### Method I

Determine by gas chromatography (2.4.13).

*Test solution.* A 5.0 per cent v/v of *ethanol* and 5.0 per cent v/v of *1-propanol* (internal standard).

*Reference solution (a).* Dilute a volume of the preparation under examination with *water* to contain between 4.0 and 6.0 per cent v/v of *ethanol*.

*Reference solution (b).* Prepare in the same manner as reference solution (a) but adding sufficient of the internal standard to produce a final concentration of 5.0 per cent v/v.

#### Chromatographic system

- a glass column 1.5 m × 4 mm, packed with porous polymer beads (100 to 120 mesh),
- temperature: column. 150°, inlet port and detector. 170°,
- nitrogen as carrier gas.

Calculate the percentage content of ethanol from the areas of the peaks due to ethanol in the chromatogram obtained with test solutions and reference solution (b).

#### Method II

For preparations where the use of Industrial Methylated Spirit is permitted in the monograph, determine the content of ethanol as described in Method I but using as following solution

*Reference solution (a).* A volume of the preparation under examination diluted with water to contain between 4.0 and 6.0 per cent v/v of total ethanol and methanol.

Determine the concentration of methanol in the following manner. Using the chromatographic condition as described under Method I but using the following solutions.

*Test solution.* A 0.25 per cent v/v of methanol and 0.25 per cent v/v of 1-propanol (internal standard).

*Reference solution (a).* Dilute a volume of the preparation under examination with water to contain between 0.2 per cent and 0.3 per cent v/v of methanol.

*Reference solution (b).* Prepare in the same manner as reference solution (a) but adding sufficient of the internal standard to produce a final concentration of 0.25 per cent v/v.

The sum of the contents of ethanol and methanol is within the range specified in the individual monograph and the ratio of the content of methanol to that of ethanol is commensurate with Industrial Methylated Spirit having been used.

#### Method III

This method is intended only for certain liquid preparations containing ethanol. Where the preparation contains dissolved substances that may distil along with ethanol Method IIIB or IIIC must be followed.

#### Apparatus

The apparatus (see Fig.2.3.45-1) consists of a round-bottomed flask (A) fitted with a distillation head (B) with a steam trap and attached to a vertical condenser (C). A tube is fitted to the lower part of the condenser and carries the distillate into the lower part of a 100-ml or 250-ml volumetric flask (D). The

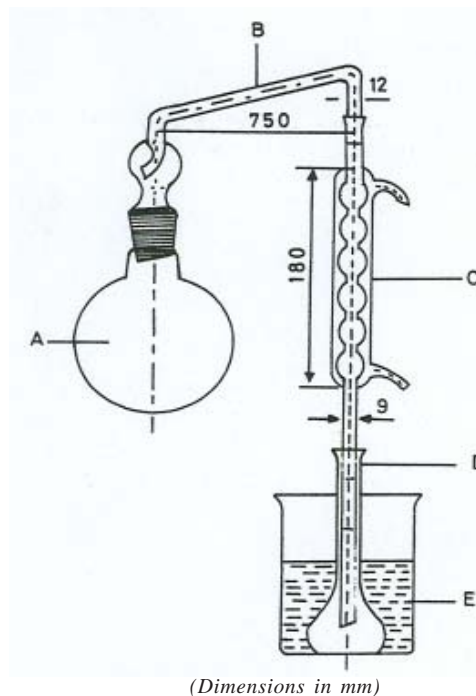

Fig. 2.3.45-1: Apparatus for Determination of Ethanol by Distillation method

volumetric flask is immersed in a beaker (E) containing a mixture of ice and water during the distillation. A disc with a circular aperture 6 cm in diameter is placed under the distillation flask (A) to reduce the risk of charring of any dissolved substances.

#### Method IIIA

Transfer 25 ml of the preparation under examination, accurately measured at 24.9° to 25.1°, to the distillation flask. Dilute with 150 ml of water and add a little pumice powder. Attach the distillation head and condenser. Distil and collect not less than 90 ml of the distillate into a 100-ml volumetric flask. Adjust the temperature to 24.9° to 25.1° and dilute to volume with distilled water at 24.9° to 25.1°. Determine the relative density at 24.9° to 25.1° (2.4.29). The values indicated in column 2 of the table (see below) are multiplied by 4 in order to obtain the percentage of ethanol by volume contained in the preparation. If the specific gravity is found to be between two values the percentage of ethanol should be obtained by interpolation. After calculation of the ethanol content, report the result to one decimal place.

*NOTES — (1) If excessive frothing is encountered during distillation, render the solution strongly acid with phosphoric acid or treat with a small amount of liquid paraffin or a silicone oil.*

*(2) The distillate should be clear or not more than slightly cloudy. If it is turbid or contains oily drops, follow Method IIIC. When steam-volatile acids are present, make the solution*

just alkaline with 1M sodium hydroxide using solid phenolphthalein as indicator before distillation.

Table

Specific gravity at 25°	Ethanol* content
1.0000	0
0.9985	1
0.9970	2
0.9956	3
0.9941	4
0.9927	5
0.9914	6
0.9901	7
0.9888	8
0.9875	9
0.9862	10
0.9850	11
0.9838	12
0.9826	13
0.9814	14
0.9802	15
0.9790	16
0.9778	17
0.9767	18
0.9756	19
0.9744	20
0.9733	21
0.9721	22
0.9710	23
0.9698	24
0.9685	25

\* Percent v/v at 15.56°.

### Method IIIB

Follow this method or the following one if the preparation under examination contains appreciable proportions of volatile materials other than ethanol and water.

Mix 25 ml of the preparation, accurately measured at 24.9° to 25.1°, with about 100 ml of water in a separating funnel. Saturate this mixture with sodium chloride, add about 100 ml of hexane and shake vigorously for 2 to 3 minutes. Allow the mixture to stand for 15 to 20 minutes. Run the lower layer into the distillation flask, wash the hexane layer in the separating funnel by shaking vigorously with about 25 ml of sodium chloride solution, allow to separate and run the wash liquor into the first saline solution. Make the mixed solutions just alkaline with 1 M sodium hydroxide

using solid phenolphthalein as indicator, add a little pumice powder and 100 ml of water, distil 90 ml and determine the percentage v/v of ethanol by Method III A beginning at the words “Adjust the temperature...”.

### Method IIIC

Transfer 25 ml of the preparation, accurately measured at 24.9° to 25.1°, to the distillation flask. Dilute with 150 ml of water and add a little pumice powder. Attach the distillation head and condenser. Distil and collect about 100 ml. Transfer to a separating funnel and determine the percentage v/v of ethanol by Method IIIB beginning at the words “Saturate this mixture...”.

## 2.3.46. Assay of Insulins

Determine by liquid chromatography (2.4.14).

*Test solution.* Prepare as directed in the individual monograph.

*Reference solution (a)* — For the assay of insulin preparations containing 100 Units per ml.

For a preparation containing a single species of insulin, dissolve in 0.01 M hydrochloric acid, as appropriate, a defined quantity of human insulin RS or porcine insulin RS, or of bovine insulin RS, to obtain a concentration of 4.0 mg per ml. For a preparation containing both bovine and porcine insulins, mix 1.0 ml of a solution containing 4.0 mg of bovine insulin RS per ml of 0.01 M hydrochloric acid and 1.0 ml of a solution containing 4.0 mg of porcine insulin RS per ml of 0.01 M hydrochloric acid.

*Reference solution (b)* — For the assay of insulin preparations containing 40 Units per ml.

Dilute 4.0 ml of reference solution (a) to 10.0 ml with 0.01M hydrochloric acid.

*Reference solution (c).* Dissolve the contents of a vial of human insulin RS in 0.01M hydrochloric acid to obtain a concentration of 4.0 mg per ml.

*Reference solution (d).* Dissolve the contents of a vial of porcine insulin RS in 0.01M hydrochloric acid to obtain a concentration of 4.0 mg per ml.

*Reference solution (e).* Dilute 1.0 ml of reference solution (a) to 10.0 ml with 0.01M hydrochloric acid.

*Reference solution (f).* Dilute 1.0 ml of reference solution (b) to 10.0 ml with 0.01M hydrochloric acid.

*Resolution solution.* Mix 1.0 ml of reference solution (c) and 1.0 ml of reference solution (d).

Maintain the solutions at 2° to 10° and use within 48 hours. If an automatic injector is used, maintain the temperature at 2° to 10°.

## Chromatographic system

- a stainless steel column 25 cm x 4.6 mm, packed with octadecylsilane bonded to porous silica (5 µm)(such as Ultrasphere ODS),
- mobile phase A. dissolve 28.4 g of *anhydrous sodium sulphate* in *water* and dilute to 1000 ml with the same solvent; add 2.7 ml of *phosphoric acid*; adjust the pH to 2.3, if necessary with *ethanolamine*; filter and degas,
- mobile phase B. mix 550 ml of mobile phase (a) with 450 ml of *acetonitrile*; warm the solution to a temperature not lower than 20° in order to avoid precipitation (mixing of mobile phase (a) with acetonitrile is endothermic); filter and degas,
- column temperature 40°,
- flow rate 1 ml per minute,
- spectrophotometer set at 214 nm,
- a 20 µl loop injector.

Elute with a mixture of 42 volumes of mobile phase (a) and 58 volumes of mobile phase (b), adjusted if necessary.

Inject the resolution solution and reference solution (d). Record the chromatogram of the resolution solution until the peak corresponding to the principal peak in the chromatogram obtained with reference solution (d) is clearly visible. In the chromatogram obtained with the resolution solution, identify the peaks due to porcine insulin and human insulin. The test is not valid unless the resolution between the peaks due to human insulin and porcine insulin is at least 1.2. If necessary, adjust the concentration of acetonitrile in the mobile phase until this resolution is achieved.

Inject the test solution and 20 µl of either reference solutions (a) and (e), for insulin preparations containing 100 Units per ml, or 20 µl of reference solutions (b) and (f), for insulin preparations containing 40 Units per ml. If necessary, make further adjustments of the mobile phase in order to ensure that the antimicrobial preservatives present in the test solution are well separated from the insulin and show shorter retention times. A small reduction in the concentration of acetonitrile increases the retention time of the insulin peaks relatively more than those of the preservatives. If necessary, after having carried out the chromatography of a solution wash the column with a mixture of equal volumes of *acetonitrile* and *water* for a sufficient time to ensure elution of any interfering substances before injecting the next solution. The test is not valid unless the area of the principal peak in the chromatogram obtained with reference solution (a) or (b) is  $10 \pm 0.5$  times the area of the principal peak in the chromatogram obtained with reference solution (e) or (f). If this test fails, adjust the injection volume between 10 µl and 20 µl, in order to be in the linearity range of the detector.

Calculate the content of insulin plus A21 desamido insulin from the area of the peak due to the bovine, porcine or human

insulin and that of any peak due to the A21 desamido insulin, using the declared content of insulin plus A21 desamido insulin in *bovine insulin RS*, *porcine insulin RS* or *human insulin RS*, as appropriate. For preparations containing both bovine and porcine insulin use the sum of the areas of both the bovine and porcine insulin peaks and of the peaks due to the A21 desamido insulin<sup>1</sup> derivatives.

<sup>1</sup>100 Units are equivalent to 3.47 mg of human insulin, to 3.45 mg of porcine insulin and to 3.42 mg of bovine insulin.

### 2.3.47. Peptide Mapping

The following procedure serves to identify the various fragments of insulin by selective cleavage of the peptide bonds, chromatographic separation of the fragments and comparison with standard insulin.

Determine by liquid chromatography (2.4.14).

**Test solution.** Prepare a 0.2 per cent w/v solution of the substance under examination in 0.01M *hydrochloric acid* and transfer 500 µl of this solution to a stoppered clean tube. Add 2.0 ml of *HEPES buffer solution pH 7.5* and 400 µl of a 0.1 per cent w/v solution of *Staphylococcus aureus strain V8 protease*. Close the tube and incubate at 25° for 6 hours. Stop the reaction by adding 2.9 ml of *sulphate buffer solution pH 2.0*.

**Reference solution.** Prepare in the same manner as for the test solution but using as appropriate, *porcine insulin RS* or *bovine insulin RS* or *human insulin RS* in place of the substance under examination.

## Chromatographic system

- a stainless steel column 10 cm x 4.6 mm, packed with octadecylsilyl silica gel (3 µm) with a pore size of 8 nm,
- column temperature. 40°
- mobile phase A. a filtered and degassed mixture of 100 ml of *acetonitrile*, 200 ml of *sulphate buffer solution pH 2.0* and 700 ml of *water*,
- mobile phase B. a filtered and degassed mixture of *sulphate buffer solution pH 2.0*, 400 ml of *acetonitrile* and 400 ml of *water*,
- flow rate 1 ml per minute,
- spectrophotometer set at 214 nm,
- a 50 µl loop injector.

Time (mins)	Mobile phase A (per cent v/v)	Mobile phase B (per cent v/v)
0-60	90 → 30	10 → 70
60-65	30 → 0	70 → 100
65-70	0	100

At initial conditions equilibrate the column for at least 15 minutes. Carry out a blank run using the above-mentioned gradient.



Inject the test solution and the reference solution. The chromatograms obtained with the test and reference solutions are qualitatively similar. In the chromatogram obtained with the reference solution identify the peaks due digest fragments I, II and III.

The profile of the chromatogram obtained with the test solution corresponds to that of the chromatogram obtained with the reference solution.

The test is not valid unless in the chromatograms obtained with the reference solution for the peaks due to fragments II and III the symmetry factor is not more than 1.5 and the resolution factor between the peaks due to fragments II and III is not less than 1.9 for porcine and bovine insulins and not less than 3.4 for human insulin.

*Note* — The retention time of fragment I is the same for porcine insulin and for human insulin. The retention time of fragment III is the same for bovine insulin and for porcine insulin. The retention times of fragments II and IV are the same for all insulins.

### 2.3.48. Thiomersal

Take 0.1 ml of the preparation under examination containing about 50 µg per ml of *thiomersal* in a test-tube add sufficient *distilled water* to produce 1.0 ml. To this solution add 1.0 ml of *acetone*, 1.0 ml of a freshly prepared 0.0001 per cent w/v solution of *dithizone in acetone* and 0.1 ml of *sodium hydroxide (50 per cent w/v)*. Measure the absorbance (2.4.7) of the resulting solution at 558 nm using a blank prepared in the same manner using 0.1 ml of *distilled water* in place of the preparation under examination. Calculate the thiomersal content from the absorbance obtained, using calibration curve prepared by repeating the operation using 0.1 ml of a series of *thiomersal* solutions containing 25 µg, 50 µg, 75 µg, 100 µg and 125 µg per ml.

### 2.3.49. Protein

Use any of the following methods.

#### Method A

##### Biuret method

Dilute an appropriate volume with *distilled water* to give a solution containing about 5 mg of protein per ml. To 1.0 ml of

resulting solution in a test tube, add 4 ml of *biuret reagent* (prepared by dissolving 6 g of *sodium potassium tartrate* and 1.5 g of *cupric sulphate* in 500 ml of *distilled water*). Add with constant stirring 300 ml of 10 per cent *sodium hydroxide* and make the final volume to 1000 ml by adding 5 g of *potassium iodide*. Measure the absorbance (2.4.7) of the resulting test solution at 550 nm using blank prepared in the same manner by taking 1.0 ml of *distilled water*. Calculate the *protein* content from the absorbance obtained, using calibration curve prepared by repeating the operation using 1.0 ml of each of a series of bovine serum albumin solution containing 1.0 mg, 2.0 mg, 3.0 mg, 4.0 mg and 5.0 mg per ml of *protein* respectively.

#### Method B

##### Lowry's Method

Prepare a stock solution of the standard protein (example, bovine serum albumin fraction V) containing 2mg per ml protein in *distilled water*. Store the stock solution frozen at -20°. Prepare standards by diluting the stock solution with *distilled water* to give the protein concentrations of 0 mg, 10.0 µg, 20.0 µg, 50.0 µg, 100.0 µg, 200.0 µg, 500.0 µg, 1000.0 µg and 2000.0 µg per ml.

Prepare the complex forming reagent immediately before use by mixing the following stock solutions in the proportion of 100:1:1 (by volume) respectively.

*Solution a.* 2 per cent w/v solution of *sodium carbonate* in *distilled water*

*Solution b.* 1 per cent w/v solution of *copper sulphate* in *distilled water*

*Solution c.* 2 per cent w/v solution of *sodium tartrate* in *distilled water*.

Take 0.1 ml of test sample or standard protein and add 0.1 ml of *2N sodium hydroxide* and hydrolyze the mixture at 100° for 10 minutes in a heating block or boiling water bath. Cool the mixture to room temperature and add 1 ml of freshly mixed complex forming reagent. Allow the solution to stand at room temperature for 10 minutes. Add 0.1 ml of *1N Folin's reagent*, mix well and let the mixture stand at room temperature for 30 to 60 minutes. Read the absorbance (2.4.7) at 750 nm. Determine the protein concentration of the test sample by plotting a standard curve of absorbance as a function of concentration of the standard protein.



## 2.4. PHYSICAL AND PHYSICOCHEMICAL METHODS

2.4.1. Appearance of Solution	....
2.4.2. Atomic Absorption Spectrometry	....
2.4.3. Atomic Emission Spectrometry	....
2.4.4. Flame Photometry	....
2.4.5. Fluorimetry	....
2.4.6. Infrared Absorption Spectrophotometry	....
2.4.7. Ultraviolet and Visible Absorption Spectrophotometry	....
2.4.8. Boiling Range or Temperature and Distillation Range	....
2.4.9. Conductivity	....
2.4.10. Congealing Range or Temperature	....
2.4.11. Freezing Point	....
2.4.12. Electrophoresis	....
2.4.13. Gas Chromatography	....
2.4.14. Liquid Chromatography	....
2.4.15. Paper Chromatography	....
2.4.16. Size-exclusion Chromatography	....
2.4.17. Thin-layer Chromatography	....
2.4.18. Jelly Strength	....
2.4.19. Loss on Drying	....
2.4.20. Loss on Ignition	....
2.4.21. Melting Range or Temperature	....
2.4.22. Optical Rotation and Specific Optical Rotation	....
2.4.23. Osmolality	....
2.4.24. pH Values	....
2.4.25. Potentiometric Titration	....
2.4.26. Solubility	....
2.4.27. Refractive Index	....
2.4.28. Viscosity	....
2.4.29. Weight per ml and Relative Density	....
2.4.30. Total Organic Carbon in Water	....

2.4.31. Differential Scanning Calorimetry (DSC)	....
2.4.32. Capillary Electrophoresis	....
2.4.33. Isoelectric Focusing	....

## 2.4.1. Appearance of Solution

### Clarity of Solution

#### Special Reagents

**Standard Suspension.** Dissolve 1.0 g of *hydrazine sulphate* in sufficient *water* to produce 100.0 ml and set aside for about 6 hours. To 25.0 ml of this solution add 25.0 ml of a 10.0 per cent w/v solution of *hexamine*, mix well and allow to stand for 24 hours. Keep in a glass container with a smooth internal surface in which the suspension does not adhere to the glass. Store in this manner, the suspension is stable for about 2 months.

Prepare the *standard suspension* by diluting 15 ml of the well-mixed suspension to 1000 ml with *water*. The *standard suspension* should be used within 24 hours of preparation.

**Opalescence Standards.** Prepare opalescence standards by mixing aliquots of the *standard suspension* with *water* as indicated in Table 1. Each opalescence standard should be shaken well before use.

Table 1

Opalescence Standard	Standard Suspension (ml)	Water (ml)
OS1	5.0	95.0
OS2	10.0	90.0
OS3	30.0	70.0
OS4	50.0	50.0

**Method.** Transfer to a flat-bottom test-tube of neutral glass, 15 to 25 mm in diameter, a suitable volume of the solution under examination such that the test-tubes is filled to a depth of 40 mm. Into another matched test-tube add the same volume of the freshly prepared *opalescence standard*. After 5 minutes, compare the contents of the test-tubes against a black background by viewing under diffused light down the vertical axis of the tubes.

### Clarity or opalescence

Express the degree of opalescence in terms of the opalescence standard. A liquid is considered clear if its clarity is the same as that of *water* or of the solvent used for preparing the solution under examination or if its opalescence is not more than that of opalescence standard OS1.

### Colour of Solution

#### Special Reagents

**Ferric Chloride Colorimetric Solution (FCS).** Dissolve about 55 g of *ferric chloride hexahydrate* in enough of a mixture of

25 ml of *hydrochloric acid* and 975 ml of *water* to produce 1000 ml. Pipette 10 ml of this solution into a 250-ml iodine flask, add 15 ml of *water*, 3 g of *potassium iodide* and 5 ml of *hydrochloric acid* and allow the mixture to stand for 15 minutes. Dilute with 100 ml of *water* and titrate the liberated iodine with 0.1 M *sodium thiosulphate* using 0.5 ml of *starch solution*, added towards the end of the titration, as indicator. Carry out a blank titration.

1 ml of 0.1 M *sodium thiosulphate* is equivalent to 0.02703 g of  $\text{FeCl}_3 \cdot 6\text{H}_2\text{O}$ . Adjust the final volume of the solution by the addition of enough of the mixture of *hydrochloric acid* and *water* so that each ml contains 0.045 g of  $\text{FeCl}_3 \cdot 6\text{H}_2\text{O}$ .

The solutions should be stored protected from light and standardised before use.

**Cobaltous chloride Colorimetric Solution (CCS).** Dissolve about 65 g of *cobaltous chloride* in enough of a mixture of 25 ml of *hydrochloric acid* and 975 ml of *water* to produce 1000 ml. Pipette 5 ml of this solution into a 250 ml iodine flask, add 5 ml of *hydrogen peroxide solution (10 volume)* and 15 ml of *sodium hydroxide solution*, boil for 10 minutes, cool and add 2 g of *potassium iodide* and 60 ml of *dilute sulphuric acid*. Dissolve the precipitate by gentle shaking, if necessary, and titrate the liberated iodine with 0.1 M *sodium thiosulphate* using 0.5 ml of *starch solution*, added towards the pink end-point, as indicator. Carry out a blank titration.

1 ml of 0.1 M *sodium thiosulphate* is equivalent to 0.02379 g of  $\text{CoCl}_2 \cdot 6\text{H}_2\text{O}$ . Adjust the final volume of the solution by the addition of enough of the above mixture of *hydrochloric acid* and *water* so that each ml contains 0.0595 g of  $\text{CoCl}_2 \cdot 6\text{H}_2\text{O}$ .

**Cupric Sulphate Colorimetric Solution (CSS).** Dissolve about 65 g of *cupric sulphate* in enough of a mixture of 25 ml of *hydrochloric acid* and 975 ml of *water* to produce 1000 ml. Pipette 10 ml of this solution into a 250 ml iodine flask, add 40 ml of *water*, 4 ml of *acetic acid*, 3 g of *potassium iodide*, and 5 ml of *hydrochloric acid* and titrate the liberated iodine with 0.1 M *sodium thiosulphate* using 0.5 ml of *starch solution*, added towards the pale brown end-point, as indicator. Carry out a blank titration.

1 ml of 0.1 M *sodium thiosulphate* is equivalent to 0.02497 g of  $\text{CuSO}_4 \cdot 5\text{H}_2\text{O}$ . Adjust the final volume of the solution by the addition of enough of the above mixture *hydrochloric acid* and *water* so that each ml contains 0.0624 g of  $\text{CuSO}_4 \cdot 5\text{H}_2\text{O}$ .

**Reference Solution.** Prepare by mixing the volumes of *colorimetric solutions* and *hydrochloric acid (1 per cent w/v HCl)* as indicated in Table 2.

*NOTE* — *Reference solutions must be prepared immediately before use from the Colorimetric solutions which may be stored in refrigerator.*

**Method**

Transfer to a flat bottom test tube of neutral glass 15 to 25 mm in diameter, a suitable volume of a liquid been examined such that the test tube is filled to a depth of 40 mm. Into another matched test tube add the same volume of water or of the solvent used for preparing the solution being examined or of the reference solution stated in the individual monograph.

Compare the colours in diffused light viewing vertically against a white background.

**Colourless Solution.** A solution is considered colourless if it has the same appearance as *water* or the solvent used for preparing the solution or is not more intensely coloured than *reference solution BS8*.

Table 2

Colour of reference solution	Reference solution	FCS (ml)	CCS (ml)	CSS (ml)	Hydrochloric Acid (1 per cent w/v HCl) (ml)
Yellow	YS1	24.0	6.0	0	70.0
	YS2	18.0	4.5	0	77.5
	YS3	12.0	3.0	0	85.0
	YS4	6.0	1.5	0	92.5
	YS5	3.2	0.8	0	96.0
	YS6	1.6	0.4	0	98.0
	YS7	0.8	0.2	0	99.0
Greenish Yellow	GYS1	24.0	0.5	0.5	75.0
	GYS2	14.0	0.1	0.1	85.5
	GYS3	8.5	0.05	0.05	91.5
	GYS4	5.0	0.05	0.05	95.0
Brownish Yellow	BYS1	24.0	10.0	4.0	62.0
	BYS2	18.0	7.5	3.0	71.5
	BYS3	12.0	5.0	2.0	81.0
	BYS4	6.0	2.5	1.0	90.5
	BYS5	3.0	1.5	0.5	95.0
	BYS6	1.5	0.8	0.2	97.5
	BYS7	1.0	0.4	0.1	98.5
Brown	BS1	22.5	22.5	18.0	37.0
	BS2	15.0	15.0	12.0	58.0
	BS3	11.2	11.2	9.0	68.5
	BS4	7.5	7.5	6.0	79.0
	BS5	3.7	3.7	3.0	89.5
	BS6	1.5	1.5	1.2	96.0
	BS7	0.8	0.8	0.6	98.0
	BS8	0.4	0.4	0.2	99.0
Red	RS1	10.0	20.0	0	70.0
	RS2	7.5	15.0	0	77.5
	RS3	5.0	10.0	0	85.0
	RS4	3.8	7.6	0	88.5
	RS5	2.5	5.0	0	92.5
	RS6	1.3	2.6	0	96.0
	RS7	0.5	1.0	0	98.5

## 2.4.2. Atomic Absorption Spectrometry

This technique is based on the fact that when atoms, ions or ion complexes of an element in the ground state are atomised in a flame, they absorb light at the characteristic wavelength of that element. If the absorption process takes place in the flame under reproducible conditions, the absorption is proportional to the number of absorbing atoms.

The measurement of the absorption of radiation by the atomic vapour of the element generated from a solution of that element is the basis of atomic absorption spectrometry. The determination is carried out at the wavelength of one of the absorption lines of the element concerned. The assay is done by comparing the absorbance of the test solution with that of the reference preparation.

### Apparatus

An atomic absorption spectrophotometer consists of an emission source that provides the characteristic spectral line of the element such as a hollow-cathode discharge lamp, a monochromator to select the required resonance line, a system for introducing the sample solution into a flame and a detector system.

Since the radiation to be absorbed by the element in the test solution is usually of the same wavelength as that of its emission line, the element in the hollow-cathode lamp is the same as the element to be determined and usually a different lamp is used for each element.

The method of introducing the substance to be analysed depends on the type of atomic generator used. In flame atomic absorption, the sample is nebulised and water is the solvent of choice for preparing the test and reference solutions. Organic solvents may also be used if precautions are taken to ensure that the solvent does not interfere with the stability of the flame. In furnace atomic absorption, the sample may be introduced as a solution in water or in an organic solvent.

The atomic vapour may also be generated outside the spectrophotometer as in the case of mercury vapour generator or hydride vapour generator.

### Methods

The manufacturer's instructions for the operation of the instrument should be strictly followed.

Unless otherwise directed in the individual monograph, one or the other of the following methods may be used. In Method A, measurements are made by comparison with solutions containing a known amount of the element being analysed by means of a calibration graph and in Method B comparison is made by means of progressive addition of the reference solution of the element being analysed.

**Method A** – Prepare the solution of the substance under examination (test solution) as directed in the monograph. Prepare not fewer than three standard solutions of the element to be determined, covering the concentration range recommended by the manufacturer of the instrument for the element to be determined and including the expected value in the test solution. Any reagent used in the preparation of the test solution should be added to the standard solutions in the same concentration. After calibrating the instrument as directed above, introduce each standard solution into the flame three times, and record the steady reading, washing the apparatus thoroughly with *water* after each introduction. Between each measurement a blank solution should be aspirated and the reading should be allowed to return to zero level. If a furnace is used, it is fired between readings.

Prepare a calibration curve by plotting the mean of each group of three readings against the concentration of the reference solution and determine the concentration of the element to be determined from the calibration graph.

**Method B** – Place in each of not fewer than three similar volumetric flasks equal volumes of the test solution as directed in the monograph. Add to all but one of these flasks a measured amount of the specified standard solutions containing steadily increasing amounts of the element being determined. Dilute the contents of each flask to the required volume with *water*. After calibrating the spectrometer as directed above, record the reading of each solution three times. Plot the mean of the readings against concentration of a graph the axes of which intersect at zero added element and zero reading. Extrapolate the straight line joining the points until it meets the extrapolated concentration axis. The distance between this point and the intersection of the axis represents the concentration of the element being determined in the solution of the substance under examination.

It is advisable to make a stock solution of higher concentration for the reference substance and then dilute it successively to get standard solutions of different concentrations. Care should be taken to avoid manual errors while making dilutions.

*NOTE* — For the purpose of this Appendix, *water* refers to deionised purified water distilled immediately before use.

## 2.4.3. Atomic Emission Spectrometry

This technique is used to determine the concentration of certain metallic ions by measuring the intensity of emission of light at a particular wavelength by the vapour of the element generated from the substance.

The measurement of the intensity of one of the emission lines of the atomic vapour of the element generated from a solution



of that element is the basis of atomic emission spectrometry. The determination is carried out at the wavelength corresponding to this emission line of the element concerned. The assay is done by comparing the intensity of emission from the test solution with that from reference preparations with known concentrations of the element to be determined.

#### Apparatus

An atomic emission spectrophotometer consists of an atomic generator of the element to be determined (such as flame, plasma, arc etc), a monochromator and a detector. If a flame is used for generating the vapour, *water* is the usual solvent for preparing the test and reference solutions. Organic solvents may also be used if precautions are taken to ensure that the solvent does not interfere with the stability of the flame.

#### Methods

The manufacturer's instructions for the operation of the instrument should be strictly followed. The spectrometer should be operated at the prescribed wavelength setting. Introduce a blank solution into the atomic generator and adjust the instrument reading to zero. Introduce the most concentrated reference solution and adjust the sensitivity to obtain a suitable reading.

Unless otherwise directed in the individual monograph, one or the other of the following methods may be used. In Method A, measurements are made by comparison with solutions containing a known amount of the element being analysed by means of a calibration graph and in Method B comparison is made by means of progressive addition of the reference solution of the element being analysed.

**Method A** – Prepare the solution of the substance under examination (test solution) as directed in the monograph. Prepare not fewer than three standard solutions of the element to be determined, covering the concentration range recommended by the manufacturer of the instrument for the element to be determined and including the expected value in the test solution. Any reagent used in the preparation of the test solution should be added to the standard solutions in the same concentration. After calibrating the instrument as directed above, introduce each standard solution into the flame three times, and record the steady reading, washing the apparatus thoroughly with *water* after each introduction. Between each measurement a blank solution should be aspirated and the reading should be allowed to return to zero level. If a furnace is used, it is fired between readings.

Prepare a calibration curve by plotting the mean of each group of three readings against the concentration of the reference solution and determine the concentration of the element to be determined from the calibration graph.

**Method B** – Place in each of not fewer than three similar volumetric flasks equal volumes of the test solution as directed

in the monograph. Add to all but one of these flasks a measured amount of the specified standard solutions containing steadily increasing amounts of the element being determined. Dilute the contents of each flask to the required volume with *water*. After calibrating the spectrometer as directed above, record the reading of each solution three times. Plot the mean of the readings against concentration of a graph the axes of which intersect at zero added element and zero reading. Extrapolate the straight line joining the points until it meets the extrapolated concentration axis. The distance between this point and the intersection of the axis represents the concentration of the element being determined in the solution of the substance under examination.

#### 2.4.4. Flame Photometry

The following methods are based on the measurement of intensity of spectral lines emitted by elements such as sodium, potassium, calcium, etc. The substance containing the element is dissolved in an appropriate solvent (usually water) and subjected to excitation in a flame of appropriate temperature and composition.

#### Apparatus

Several instruments of suitable selectivity are available. The manufacturer's instructions for the operation of the instrument should be strictly followed.

#### Methods

Unless otherwise directed in the individual monograph, one or the other of the following methods may be used. In Method A, measurements are made by comparison of sample solutions with solutions containing a known amount of the element being analysed. Method B is suitable for samples that contain very small quantities of the element to be analysed or where there is interference from other elements.

**Method A** – Prepare a series of standard solutions containing the element to be determined in increasing concentration within the concentration range recommended for the particular instrument used. Choose the appropriate filters or adjust the monochromator to select the wavelength prescribed in the monograph. Spray water into the flame and adjust the galvanometer reading to zero. Spray the most concentrated standard solution into the flame and adjust the sensitivity so that a full-scale deflection of the galvanometer is recorded. Again spray water into the flame and when the galvanometer reading is constant readjust it to zero. Spray each standard solution into the flame three times, recording the steady galvanometer readings obtained and washing the apparatus thoroughly with water after each spraying. Prepare a calibration curve by plotting the mean of each group of three readings against the concentration. Prepare the solution of the

substance under examination as prescribed in the monograph and adjust the strength, if necessary, to bring it into the range of concentration recommended for the instrument used. Spray the solution into the flame three times, recording the galvanometer readings and washing the apparatus thoroughly with water after each spraying. Using the mean of the galvanometer readings, determine the concentration of the element being examined from the calibration curve. To confirm the concentration thus obtained, repeat the operations with a standard solution of the same concentration as that of the solution under examination.

**Method B** – Place in each of not fewer than three similar volumetric flasks equal volumes of the solution of the substance under examination prepared as prescribed in the monograph. Add to all but one of the flasks a measured amount of the prescribed standard solution to produce a series of solutions containing regularly increasing amounts of the element to be determined. Dilute the contents of each flask to the required volume with water.

Prepare the flame photometer in the manner described under Method A, using water for the adjustment to zero and the solution with the largest amount of added element to adjust the sensitivity so that full scale deflection galvanometer is recorded. Examine each solution three times and plot the mean of the readings against concentration on a graph whose origin or zero reading represents zero concentration of the added element. Extrapolate the straight line joining the points until it meets the extrapolated concentration axis at a point on the negative side. The distance between this point and the intersection of the axis represents the concentration of the element in the solution being examined.

### 2.4.5. Fluorimetry

This procedure uses the measurement of the intensity of the fluorescent light emitted by the substance under examination in relation to that emitted by a given reference standard.

#### Apparatus

A simple filter fluorimeter or a more sophisticated spectrophotofluorimeter may be used but the latter is superior for analytical purposes on account of wavelength selectivity, accuracy, precision and convenience.

Operate the instrument strictly in accordance with the manufacturer's instructions.

#### Method

Dissolve the substance under examination in the solvent prescribed in the individual monograph, transfer the solution to the cell or the tube of the spectrofluorimeter or fluorimeter and illuminate it with an excitant light beam of the nominal

wavelength prescribed in the monograph and as nearly monochromatic as possible.

Measure the intensity of the emitted light at an angle of 90° to the excitant beam, after passing it through a filter which transmits predominantly light of the wavelength of the fluorescence.

For quantitative analysis, introduce into the apparatus the solvent or the mixture of solvents used to dissolve the substance under examination and set the instrument to zero. Introduce the prescribed standard solution and adjust the sensitivity of the instrument so that the reading is close to the maximum. If the adjustment is made by altering the width of the slits, a new zero setting must be made and the intensity of the standard must be measured again. Finally introduce the solution of the substance under examination and record the intensity of fluorescence. Calculate the concentration,  $c_x$  of the substance in the solution to be examined, using the expression:

$$c_x = \frac{I_x \times c_s}{I_s}$$

where,  $c_x$  = concentration of the solution to be examined,

$c_s$  = concentration of the standard solution,

$I_x$  = intensity of the light emitted by the solution to be examined, and

$I_s$  = intensity of light emitted by the standard solution.

If the intensity of the fluorescence is not directly proportional to the concentration, the measurement may be effected using a calibration curve. In some cases, measurement can be made with reference to a fixed standard such as a fluorescent glass or a solution of stated concentration of *quinine* in 0.05 M sulphuric acid or of *fluorescein* in 0.1 M sodium hydroxide. In such cases, the concentration of the substance under examination must be determined using a calibration curve previously prepared under the same conditions.

### 2.4.6. Infrared Absorption Spectrophotometry

#### A. Infrared spectrophotometry

##### Apparatus

An infrared spectrophotometer for recording the spectra in the infrared region consists of an optical system capable of providing the monochromatic light in the region of 4000  $\text{cm}^{-1}$  to 625  $\text{cm}^{-1}$  (about 2.5  $\mu\text{m}$  to 16  $\mu\text{m}$ ) and the means of measuring the quotient of the intensity of the transmitted light and the

incident light. Fourier transform infrared spectrophotometers that are replacing the conventional dispersive instruments use polychromatic radiation and calculate the spectrum in the frequency domain from the original data by Fourier transformation.

For recording infrared spectra, the instrument should comply with the following test for resolution.

#### Resolution performance of the apparatus

Record the spectrum of a polystyrene film 0.05mm in thickness. The depth of the trough from the maximum at about  $2851\text{cm}^{-1}$  ( $3.51\ \mu\text{m}$ ) to the minimum at about  $2870\ \text{cm}^{-1}$  ( $3.48\ \mu\text{m}$ ) should be greater than 6 per cent transmittance for prism instruments and 18 per cent transmittance for grating instruments, and that from the maximum at about  $1583\ \text{cm}^{-1}$  ( $6.32\ \mu\text{m}$ ) to the minimum at about  $1589\ \text{cm}^{-1}$  ( $6.29\ \mu\text{m}$ ) should be greater than 6 per cent transmittance for prism instruments and 12 per cent transmittance for grating instruments.

#### Verification of the wave number scale

The wave number scale may be verified using a polystyrene film which has maxima at the wavenumbers (in  $\text{cm}^{-1}$ ) shown.

3027.1( $\pm 0.3$ )*	1583.1 ( $\pm 0.3$ )
2924 ( $\pm 2$ )	1181.4 ( $\pm 0.3$ )
2850.7 ( $\pm 0.3$ )	1154.3 ( $\pm 0.3$ )
1944 ( $\pm 1$ )	1069.1 ( $\pm 0.3$ )
1871.0 ( $\pm 0.3$ )	1028.0 ( $\pm 0.3$ )
1801.6 ( $\pm 0.3$ )	906.7 ( $\pm 0.3$ )
1601.4 ( $\pm 0.3$ )	698.9 ( $\pm 0.5$ )

\*The numbers in parentheses indicate the accuracy with which these values have been established.

**Preparation of sample.** A sample of the substance under examination may be prepared in one of the following ways.

(a) **For normal recording.** *Liquids* — Examine a liquid as a thin film held between two plates or in a cell of suitable path-length constructed of material transparent to infrared radiation in the region to be examined.

*Liquids or solids prepared as solutions* — Prepare a solution in a suitable solvent and use a concentration and path-length to give a satisfactory spectrum over a sufficiently wide wavelength range. Absorption due to solvent should be compensated for by placing in the reference beam a similar cell containing the solvent used; it should be noted that absorption bands due to the substance under examination that coincide with strong solvent absorption will not be recorded. Suitable concentrations of the solute will vary with the substance being examined but typical concentrations are 1 per cent to 10 per cent at 0.5 to 0.1 mm path-length.

*Solids* — Examine a solid after dispersion in a suitable liquid (mull) or solid (potassium halide disc), as appropriate.

*Mulls* — Triturate 1 to 5 mg of the substance with the minimum amount of *liquid paraffin* or other suitable liquid to give a smooth creamy paste. Compress a portion of the mull between two suitable plates.

*Discs* — Triturate about 1 mg of the substance with approximately 300 mg of dry, finely powdered *potassium bromide IR* or *potassium chloride IR*, as directed. These quantities are usually suitable for a disc 13 mm in diameter. Grind the mixture thoroughly, spread it uniformly in a suitable die and compress under vacuum at a pressure of about 800 MPa. Commercial dies are available and the manufacturer's instructions should be strictly followed. Mount the resultant disc in a suitable holder in the spectrophotometer. Several factors, such as inadequate or excessive grinding, moisture or other impurities in the halide carrier, may give rise to unsatisfactory discs. A disc should be rejected, if visual inspection shows lack of uniformity or if the transmittance at about  $2000\ \text{cm}^{-1}$  ( $5\ \mu\text{m}$ ) in the absence of a specific absorption band is less than 75 per cent without compensation. If the other ingredients of tablets, injections, or other dosage forms are not completely removed from the substance being examined, they may contribute to the spectrum.

(b) **For recording by multiple reflection.** When directed in the individual monograph, prepare the sample by one of the following methods.

*Solutions* — Dissolve the substance in the appropriate solvent under the conditions described in the individual monograph. Evaporate the solution on a thallium bromo-iodide plate or any other suitable plate.

*Solids* — Place the substance on a thallium bromo-iodide plate or any other suitable plate in a manner giving uniform contact.

**Identification by reference substances.** Unless otherwise directed in the individual monograph, prepare the substance under examination and the Reference Substance in the form of discs dispersed in *potassium bromide IR* or *potassium chloride IR* and record the spectra between  $4000\ \text{cm}^{-1}$  and  $625\ \text{cm}^{-1}$  ( $2.5\ \mu\text{m}$  to  $16\ \mu\text{m}$ ) under the same operational conditions. The absorption maxima in the spectrum obtained with the substance under examination correspond in position and relative intensity to those in the spectrum obtained with the Reference Substance. When the spectra recorded in the solid state show differences in the positions of the absorption maxima, treat the substance under examination and the Reference Substance in the same manner so that they crystallise or are produced in the same form, or otherwise proceed as directed in the monograph, and then record the spectra.

**Identification by reference spectra.** Unless otherwise directed in the individual monograph or on the reference spectrum prepare the substance as a disc in a dispersion of *potassium bromide IR* and record the spectrum from 2000  $\text{cm}^{-1}$  to 625  $\text{cm}^{-1}$  (5  $\mu\text{m}$  to 16  $\mu\text{m}$ ); in some cases the spectrum should be scanned from 4000  $\text{cm}^{-1}$  (2.5  $\mu\text{m}$ ). The spectrum should be scanned using the same instrumental conditions as were used to ascertain compliance with the requirement for resolution. To allow for possible differences in wavelength calibration between the instrument on which the reference spectrum was obtained and that on which the spectrum of the substance is being recorded, suitable reference absorption maxima of a polystyrene spectrum are superimposed on the reference spectrum or the specimen should be checked with the specimen of polystyrene. These will normally occur at about 2851  $\text{cm}^{-1}$  (3.51  $\mu\text{m}$ ), 1601  $\text{cm}^{-1}$  (6.25  $\mu\text{m}$ ) and 1028  $\text{cm}^{-1}$  (9.73  $\mu\text{m}$ ), but when there is interference with any of these maxima by a band in the spectrum of the substance under examination, alternative reference maxima are marked on the reference spectrum. Similar reference maxima should be superimposed on the spectrum of the substance. With reference to these maxima of polystyrene, the positions and relative intensities of the absorption bands of the substance should conform to those of the reference spectrum. When comparing the two spectra, care should be taken to allow for the possibility of differences in resolving power between the instrument on which the reference spectrum was prepared and the instrument being used to examine the substance. A reference spectrum of a polystyrene film recorded on the same instrument as the reference spectrum of the substance is included for assessing these differences. The greatest variations due to differences in resolving power are likely to occur in the region between 4000  $\text{cm}^{-1}$  and 2000  $\text{cm}^{-1}$  (2.5  $\mu\text{m}$  to 5  $\mu\text{m}$ ).

**Reference spectra.** Infrared Reference Spectra of the articles of the pharmacopoeia are provided in Chapter 3.1.

### B. Near-infrared spectrophotometry

The near-infrared (NIR) spectral range extends from about 780 nm to about 2,500 nm (from about 12,800  $\text{cm}^{-1}$  to about 4,000  $\text{cm}^{-1}$ ). NIR spectra are dominated by C-H, N-H, O-H and S-H overtone resonances and combinations of fundamental vibrational modes. NIR bands are much weaker than the fundamental mid-IR vibrations from which they originate. Because molar absorptivities in the NIR range are low, radiation typically penetrates several millimeters into materials, including solids. Furthermore, many materials such as glass are relatively transparent in this region.

Measurements can be made directly on *in situ* samples, in addition to standard sampling and testing procedures. Physical as well as chemical information, both qualitative and quantitative, is available from NIR spectra. However, direct comparison of the spectrum obtained with the substance under

examination with a reference spectrum of a chemical reference substance, as used in infrared absorption spectrophotometry, is not appropriate. Suitable validated mathematical treatment of the data is required.

Measurements in the NIR region are influenced by many chemical and physical factors as described below; reproducibility and relevance of results depend on control of these factors and measurements are usually valid only for a defined calibration model.

**Apparatus.** All NIR measurements are based on passing light through or into a sample and measuring the attenuation of the emerging (transmitted, scattered or reflected) beam. Spectrophotometers for measurement in the NIR region consist of a suitable light source, a monochromator or interferometer. Common monochromators are acousto-optical tuneable filters (AOTF), gratings or prisms. High intensity light sources such as quartz or tungsten lamps or similar are used. The tungsten lamp light source can be highly stabilised. Therefore many NIR instruments have the single-beam design. Silicon, lead sulphide, indium arsenide, indium gallium arsenide, mercury cadmium telluride (MCT) and deuterated triglycine sulphate are commonly used detector materials. Conventional cuvette sample holders, fibre-optic probes, transmission dip cells and spinning or traversing sample holders are a few common sampling devices. The selection is based on the intended application, paying particular attention to the suitability of the sampling system for the type of sample to be analysed. Suitable data processing and evaluation units are usually part of the system.

### Measurement methods

**Transmission mode.** Transmittance ( $T$ ) is a measure of the decrease in radiation intensity at given wavelengths when radiation is passed through the sample. The sample is placed in the optical beam between the source and detector. The arrangement is analogous to that in many conventional spectrophotometers and the result can be presented directly in terms of transmittance ( $T$ ) or/and absorbance ( $A$ ).

$$T = \frac{I}{I_0}$$

where,  $I_0$  = intensity of incident radiation,

$I$  = intensity of transmitted radiation,

$$A = -\log_{10} T = \log_{10} \left( \frac{I_0}{I} \right) = \log_{10} \left( \frac{I_0}{I} \right)$$

**Diffuse reflection mode.** The diffuse reflection mode gives a measure of reflectance ( $R$ ), the ratio of the intensity of light reflected from the sample ( $I$ ) to that reflected from a background or reference reflective surface ( $I_r$ ). NIR radiation can penetrate



a substantial distance into the sample, where it can be absorbed by vibrational combinations and overtone resonances of the analyte species present in the sample. Non-absorbed radiation is reflected back from the sample to the detector. NIR reflectance spectra are typically obtained by calculating and plotting  $\log(1/R)$  versus the wavelength or wavenumbers.

$$R = \frac{I}{I_r}$$

where,  $I$  = intensity of light diffusively reflected from the sample,

$I_r$  = intensity of light reflected from the background or reference reflective surface,

$$A_R = \log_{10} \left( \frac{I}{R} \right) = \log_{10} \left( \frac{I_r}{I} \right)$$

**Transflection mode.** This mode is a combination of transmittance and reflectance. In the measurement of transmittance ( $T^*$ ) a mirror or a diffuse reflectance surface is used to reflect the radiation transmitted through the sample a second time and thus doubling the pathlength. Non-absorbed radiation is reflected back from the sample to the detector.

$$T^* = \frac{I}{I_T}$$

where,  $I_T$  = intensity of transflected radiation, without sample

$I$  = intensity of transmitted and reflected radiation measured with the sample,

$$A^* = \log_{10} \left( \frac{I}{T^*} \right)$$

#### Sample preparation/presentation

**Transmission mode.** The measurement of transmittance ( $T$ ) is dependent on a background transmittance spectrum for its calculation. A background reference can be air, an empty cell, and a solvent blank or in special cases a reference sample. The method generally applies to liquids, diluted or undiluted, dispersions, solutions and solids. For transmittance measurements of solids, a suitable sample accessory is to be used. The samples are examined in a cell of suitable path length (generally 0.5-4 mm), transparent to NIR radiation, or by immersion of a fibre optic probe of a suitable configuration, which yields a spectrum situated in a zone of transmission compatible with the specifications of the apparatus and appropriate for the intended purpose.

**Diffuse reflection mode.** This method generally applies to solids. The sample is examined in a suitable device. Care must

be taken to make the measuring conditions as reproducible as possible from one sample to another. When immersing a fibre optic probe in the sample, care must be taken in the positioning of the probe to ensure that it remains stationary during the acquisition of the spectra and that the measuring conditions are as reproducible as possible from one sample to another. The reflected radiation of a background reference is scanned to obtain the baseline, and then the reflectance of one or more analytical samples is measured. Common reflectance references are ceramic tiles, perfluorinated polymers and gold. Other suitable materials may be used. Only spectra measured against a background possessing the same optical properties can be directly compared with one another. The particle size, water of hydration and state of solvation must be taken into consideration.

**Transflection mode.** A reflector is placed behind the sample so as to double the pathlength. This configuration can be adopted to share the same instrument geometry with reflectance and fibre optic probe systems where the source and the detector are on the same side of the sample. The sample is examined in a cell with a mirror or a suitable diffuse reflector, made either of metal or of an inert substance (for example titanium dioxide) not absorbing in the NIR region.

#### Factors affecting spectral response

Factors that can affect the spectral response are sample temperature, moisture and solvent residues, sample thickness, sample optical properties, polymorphism and the age of samples. Care must be taken to ensure that samples for NIR analysis are representative of those used for calibration. Suitable adjustments may be made to the test conditions in order to cope with these factors.

**Control of instrument performance.** Use the apparatus according to the manufacturer's instructions and carry out the prescribed verification at regular intervals, according to the use of the apparatus and the substances to be tested.

**Verification of the wavelength scale (Except for filter apparatus).** Verify the wavelength scale employed, generally in the region between about 780 nm and about 2,500 nm (about 12,800  $\text{cm}^{-1}$  to about 4,000  $\text{cm}^{-1}$ ) or in the intended spectral range using one or more suitable wavelength standards which have characteristic maxima or minima within the range of wavelengths to be used. Dichloromethane or a mixture of rare-earth oxides are suitable reference materials. Take one spectrum with the same spectral resolution used to obtain the certified value, and measure the position of at least 3 peaks distributed over the range used. Acceptable tolerances are  $\pm 1$  nm at 1,200 nm,  $\pm 1$  nm at 1,600 nm and  $\pm 1.5$  nm at 2,000 nm ( $\pm 8$   $\text{cm}^{-1}$  at 8,300  $\text{cm}^{-1}$ ,  $\pm 4$   $\text{cm}^{-1}$  at 6,250  $\text{cm}^{-1}$  and  $\pm 4$   $\text{cm}^{-1}$  at 5,000  $\text{cm}^{-1}$ ). For the reference material used, apply the tolerance for the nearest wavelength (wavenumber) from the above for each peak used. For FT instruments, the calibration of the



wavenumber scale may be performed using a narrow water-vapour line at  $7299.86\text{ cm}^{-1}$  or a narrow line from a certified material. For rare-earth oxides, NIST 1920 (a) is the most appropriate reference.

**Measurement in transmission mode.** *Dichloromethane* may be used at an optical path length of 1.0 mm. It has characteristic sharp bands at 1,155 nm, 1,366 nm, 1,417 nm, 1,690 nm, 1,838 nm, 1,894 nm, 2,068 nm and 2,245 nm. The bands at 1,155 nm, 1,417 nm, 1,690 nm and 2,245 nm are used for calibration. Other suitable standards may also be used.

**Measurement in diffuse reflection (reflectance) mode.** A mixture of dysprosium, holmium and erbium oxides (1+1+1 by mass) or other certified material may be used. This reference material exhibits characteristic peaks at 1,261 nm, 1,681 nm and 1,935 nm. If it is not possible to use external solid standards and if measurements of diffuse reflection are carried out in cells or if fibre optic probes are used, a suspension of 1.2 g of *titanium dioxide* in about 4 ml of *dichloromethane*, vigorously shaken, is used directly in the cell or probe. The spectrum is recorded after 2 min. Titanium dioxide has no absorption in the NIR range. Spectra are recorded with a maximum nominal instrument bandwidth of 10 nm at 2,500 nm ( $16\text{ cm}^{-1}$  at  $4,000\text{ cm}^{-1}$ ). Measurement is made of the position of at least 3 peaks distributed over the range used. The acceptance tolerances are given under Verification of the wavelength scale. For the reference material used, apply the tolerance for the nearest wavelength (wavenumber) for each peak used.

**Verification of the wavelength repeatability (Except for filter apparatus).** Verify the wavelength repeatability using suitable standards. The standard deviation of the wavelength is consistent with the specifications of the instrument manufacturer.

**Verification of photometric linearity and response stability.** Verification of photometric linearity is demonstrated with a set of transmission or reflection standards with known values of transmittance or reflectance in percentage. For reflectance measurements, carbon-doped polymer standards are available. At least 4 reference standards in the range of 10.0 to 90.0 per cent such as 10.0 per cent, 20.0 per cent, 40.0 per cent and 80.0 per cent with respective absorbance values of 1.0, 0.7, 0.4 and 0.1 are used. If the system is used for analytes with absorbances higher than 1.0, a 2.0 per cent and/or 5.0 per cent standard is added to the set. Plot the observed absorbance values against the reference absorbance values and perform a linear regression. Acceptable tolerances are  $1.00 \pm 0.05$  for the slope and  $0.00 \pm 0.05$  for the intercept.

Spectra obtained from reflectance standards are subject to variability due to the difference between the experimental conditions under which they were factory-calibrated and those under which they are subsequently put to use. Hence, the percentage reflectance values supplied with a set of calibration

standards may not be useful in the attempt to establish an "absolute" calibration for a given instrument. But as long as the standards do not change chemically or physically and the same reference background is used as was used to obtain the certified values, subsequent measurements of the same standards under identical conditions including precise sample positioning give information on long-term stability of the photometric response. A tolerance of  $\pm 2$  per cent is acceptable for long-term stability; this is only necessary if spectra are used without pre-treatment.

**Verification of photometric noise.** Determine the photometric noise using a suitable reflectance standard, for example white reflective ceramic tiles or reflective thermoplastic resins (for example, PTFE). Scan the reflection standard over a suitable wavelength/wavenumber range in accordance with the manufacturer's recommendation and calculate the photometric noise as peak-to-peak noise. The value is approximately twice the standard deviation. The photometric noise is consistent with the specification of the spectrophotometer.

#### Qualitative analysis

**Establishment of reference spectra.** Record the spectra of a suitable number of batches of the substance which have been fully tested according to established specifications and which exhibit the variation typical for the substance to be analysed (for example, manufacturer, physical form, particle size). The set of spectra represents the information for identification and characterisation that defines the similarity border for that substance and is the entry for that substance in the spectral collection used to identify the substance. The number of substances in a collection depends on the specific application. All spectra should have the same: (a) spectral range and number of data points; (b) technique of measurement; (c) data pre-treatment.

If sub-groups are created, the above criteria are applied independently for each group. The collection of spectra may be represented in different ways defined by the mathematical technique used for identification. These may be: (a) all individual spectra representing the substance; (b) a mean spectrum of each batch of substance; (c) if necessary, a description of the variability within the substance spectra. (d) electronic raw data for the preparation of the spectral collection must be archived.

**Pre-treatment of data.** In many cases, and particularly for reflection mode spectra, some form of mathematical pretreatment of the spectrum may be useful before the development of a classification or calibration model. The aim can be to reduce baseline variations, to reduce the impact of known variations that are interfering in the subsequent mathematical models, or to compress data before use. Typical methods are multiplicative scatter correction (MSC), the Kubelka-Munk transforms, spectral compression techniques

that may include windowing and noise reduction and the numerical calculation of the first- or second-order derivative of the spectrum. Higher-order derivatives are not recommended. In some cases spectra may also be normalised, for example against the maximum absorbance, the mean absorbance or the integrated absorbance area under the spectrum.

Caution must be exercised when performing any mathematical transformation, as artefacts can be introduced or essential information (important with qualification methods) can be lost. An understanding of the algorithm is required and in all cases the rationale for the use of transform must be documented.

**Data evaluation.** Direct comparison of the spectrum of the substance under investigation is made with the individual or mean reference spectra of all substances in the database on the basis of their mathematical correlation or other suitable algorithms. A set of known reference mean spectra and the variability around this mean can be used with an algorithm for classification. The reliability of the algorithm chosen for a particular application has to be validated. For example, correlation coefficient, the sum of squared residuals or the distance using cluster analysis must comply with the acceptance limits defined in the validation procedure.

**Validation of the database.** Parameters to be taken into account are specificity and robustness.

#### Quantitative analysis

##### Establishment of a spectral data base for a calibration model.

Calibration is the process of constructing a mathematical model to relate the response from an analytical instrument to the properties of the samples. Any calibration algorithm that can be clearly defined in an exact mathematical expression and gives suitable results can be used. Record spectra of a suitable number of samples with known values of the content throughout the range to be measured (for example, content of water). Wavelengths used in the calibration model can be compared to the known bands of the analyte and those of the matrix to verify that the bands of the analyte of interest are being used by the calibration. Establish the calibration model with about two-thirds of the measured samples. Compare the remaining one-third of the measured samples with the database. All samples must give quantitative results within a precision interval as defined by the intended purpose of the method. Correct quantification must be demonstrated in the presence of variations in the matrix within the specified range. Multiple linear regression (MLR), partial least squares (PLS) and principal component regression (PCR) are commonly used. For PLS or PCR calibrations, the coefficients or the loadings can be plotted and the regions of large coefficients compared with the spectrum of the analyte. Raw data for the preparation of the calibration model must be archived, without data pretreatment.

**Pre-treatment of data.** Data pre-treatment can be defined as the mathematical transformation of the NIR spectral data to enhance spectral features and/or remove or reduce unwanted sources of variation prior to the development of the calibration model. Many suitable algorithms for data pre-treatment and calibration exist. The selection is based on the suitability for the intended use. Wavelength selection may enhance the efficiency of calibration models such as MLR (for example, in particle-size determination). It is useful to delete certain ranges of the wavelength scale in some cases, for example in the determination of water of hydration. Wavelength compression may be applied to the data.

**Validation.** The conventional analytical performance characteristics should be considered for demonstrating the validation of NIR methods. Specific acceptance criteria for each validation parameter must be consistent with the intended use of the method.

**Ongoing model evaluation.** NIR models validated for use should be subjected to ongoing performance evaluation and monitoring of validation parameters. If discrepancies are found, corrective action will be necessary.

**Transfer of databases.** When databases are transferred to another instrument, spectral range, number of data points, spectral resolution and other parameters have to be taken into consideration. Further procedures and criteria must be applied to demonstrate that the model remains valid with the new database or new instrument.

## 2.4.7. Ultraviolet and Visible Absorption Spectrophotometry

Ultraviolet and visible absorption spectrophotometry is the measurement of the absorption of monochromatic radiation by solutions of chemical substances, in the range of 185 nm to 380 nm, and 380 nm to 780 nm of the spectrum, respectively.

The magnitude of the absorption of a solution is expressed in terms of the absorbance,  $A$ , defined as the logarithm to base 10 of the reciprocal of transmittance ( $T$ ) for monochromatic radiation:

$$A = \log_{10} (I_0/I)$$

where  $I_0$  is the intensity of the incident radiation  $I$  is the intensity of the transmitted radiation. The absorbance depends on the concentration of the absorbing substance in the solution and the thickness of the absorbing layer taken for measurement.

For convenience of reference and for ease in calculations, the specific absorbance of a 1 per cent w/v solution is adopted in this Pharmacopoeia for several substances unless otherwise indicated, and it refers to the absorbance of a 1 per cent w/v solution in a 1 cm cell and measured at a defined wavelength. It is evaluated by the expression

$$A (1 \text{ per cent, } 1 \text{ cm}) = A/cl,$$

where  $c$  is the concentration of the absorbing substance expressed as percentage w/v and  $l$  is the thickness of the absorbing layer in cm. The value of  $A$  (1 per cent, 1 cm) at a particular wavelength in a given solvent is a property of the absorbing substance.

Unless otherwise stated, measure the absorbance at the prescribed wavelength using a path length of 1 cm and at 24° to 26°. Unless otherwise stated, the measurements are carried out with reference to the same solvent or the same mixture of solvents.

### Apparatus

A spectrophotometer, suitable for measuring in the ultraviolet and visible ranges of the spectrum consists of an optical system capable of producing monochromatic light in the range of 200 nm to 800 nm and a device suitable for measuring the absorbance.

The two empty cells used for the solutions under examination and the reference liquid must have the same spectral characteristics. Where double-beam-recording instruments are used, the solvent cell is placed in the reference beam.

**Control of wavelengths.** Verify the wavelength scale using the absorption maxima of *holmium perchlorate solution*, the line of hydrogen or deuterium discharge lamp or the lines of a mercury vapour are shown below. The permitted tolerance is  $\pm 1$  nm for the range 200 nm to 400 nm and  $\pm 3$  nm for the range 400 nm to 600 nm

241.15 nm (Ho)	404.66 nm (Hg)
253.70 nm (Hg)	435.83 nm (Hg)
287.15 nm (Ho)	486.00 nm (Db)
302.25 nm (Hg)	486.10 nm (Hb)
313.16 nm (Hg)	536.30 nm (Ho)
334.15 nm (Hg)	546.07 nm (Hg)
361.50 nm (Ho)	576.96 nm (Hg)
365.48 nm (Hg)	579.07 nm (Hg)

**Control of absorbance.** Check the absorbance using suitable filters or a solution of *potassium dichromate UV* at the wavelengths indicated in Table 1, which gives for each wavelength the exact values and permitted limits of the specific absorbance. The tolerance for the absorbance is  $\pm 0.01$ .

Use solutions of *potassium dichromate UV* which has been previously dried to constant weight at 130°. For the control of absorbance at 235 nm, 257 nm, 313 nm and 350 nm, dissolve 57.0-63.0 mg of *potassium dichromate UV* in 0.005 M *sulphuric acid* and dilute to 1000.0 ml with the same acid. For the control of absorbance at 430 nm, dissolve 57.0-63.0 mg of *potassium dichromate UV* in 0.005 M *sulphuric acid* and dilute to 100.0 ml with the same acid.

Table 1

Wavelength (nm)	Specific absorbance	Maximum Tolerance
235	124.5	122.9 to 126.2
257	144.0	142.8 to 145.7
313	48.6	47.0 to 50.3
350	106.6	104.9 to 108.2
430	15.9	15.7 to 16.1

**Limit of stray light.** Stray light may be detected at a given wavelength with suitable filters or solutions; for example, absorbance of a 1.2 per cent w/v solution of *potassium chloride* in a 1 cm cell should be greater than 2.0 at about 200 nm when compared with *water* as reference liquid.

**Resolution power.** When stated in a monograph, record the spectrum of 0.02 per cent v/v solution of *toluene* in *hexane UV*. The ratio of the absorbance at the maximum at about 269 nm to that at the maximum at about 266 nm is not less than 1.5 unless otherwise specified in the monograph.

**Spectral slit width.** When measuring the absorbance at an absorption maximum the spectral slit width must be small compared with the half width of the absorption band otherwise erroneously low absorbance will be measured. Particular care is needed for certain substances and the instrumental slit width used should always be such that further reduction does not result in an increased absorbance reading.

**Cells.** The absorbances of the cells intended to contain the solution under examination and the reference liquid, when filled with the same solvent should be identical. If this is not the case, an appropriate correction must be applied. The tolerance on the path length of the cells used is  $\pm 0.005$  cm. Cells should be cleaned and handled with great care.

**Solvents.** In measuring the absorbance of a solution at a given wavelength, the absorbance of the reference cell and its contents should not exceed 0.4 and should preferably be less than 0.2 when measured the reference to air at the same wavelength. The solvent in the reference cell should be of the same lot as that used to prepare the solution and must be free from fluorescence at the wavelength of measurement. *Ethanol (95 per cent)*, *ethanol*, *methanol*, and *cyclohexane*, used as solvents, should have an absorbance measured in a 1 cm cell at about 254 nm with reference to *water* not exceeding 0.10.

**Determination of absorbance.** Unless otherwise directed, measure the absorbance at the prescribed wavelength using a path length of 1 cm at 24° to 26°. If necessary, the path length may be varied provided that compliance with Beer's Law has been shown over the range in question.

A statement in a assay or test of the wavelength at which maximum absorption occurs implies that the maximum occurs either precisely at or within  $\pm 2$  nm of the given wavelength.

Likewise, a statement in a test of the absorbance,  $A$ , at a given wavelength or at the maximum at about a specified wavelength implies that the measured absorbance is within  $\pm 3$  per cent of the stated value.

When an assay or test prescribes the use of a *Reference Substance*, make the spectrophotometric measurements with the solution prepared from the *Reference Substance* by the official directions and then with the corresponding solution prepared from the substance under examination. Carry out the second measurement as quickly as possible after the first, using the same cell and same experimental conditions.

Unless otherwise specified, the requirements in the monographs for light absorption in the tests and assays apply to the dried or anhydrous material, where a standard is given for loss on drying of content of water, respectively. Similar considerations apply where standards are given for solvent content. In calculating the result, the loss on drying or contents of water or solvent, determined by the method specified in the monograph, are taken in to account.

#### Derivative spectrophotometry

Derivative spectrophotometry involves the transformation of absorption spectra (zero-order) into first-, second- or higher-order derivative spectra.

A first order-derivative spectrum is a plot of the gradient of the absorption curve (rate of change of the absorbance with wavelength,  $dA/d\lambda$ ) against wavelength.

A second order-derivative spectrum is a plot of the curvature of the absorption spectrum ( $d^2A/d\lambda^2$ ) against wavelength. If the absorbance follows the Beer- Lambert relationship, the second order-derivative at any wavelength  $\lambda$  is related to the concentration by the following expression.

$$d^2A/d\lambda^2 = d^2A (1 \text{ per cent, } 1 \text{ cm}) \times cd/d\lambda^2$$

where,  $A$  = the absorbance at wavelength  $\lambda$ ,  
 $A (1 \text{ per cent, } 1 \text{ cm})$  = the specific absorbance at wavelength  $\lambda$   
 $c$  = the concentration of the absorbing solute express as a percentage w/v,  
 $d$  = the thickness of the absorbing layer in cm.

**Apparatus.** A spectrophotometer complying with the requirements for Control of wavelengths and Control of absorbances described above and equipped with an analog resistance-capacitance differentiation module or a digital differentiator or another means of producing second order-derivative spectra should be used in accordance with the manufacturer's instructions. Some methods of producing second order-derivative spectra lead to a wavelength shift relative to the zero order spectrum and this should be taken into account when necessary. Unless otherwise stated in the

monograph, the spectral slit width of the spectrophotometer, where variable, should be set as described under Spectral slit width above. The cells and solvents used should comply with the statements given under Cells and Solvents respectively.

**Reagents.** The temperatures of all solutions used in the test should not differ by more than  $0.5^\circ$ .

**Resolution.** When stated in a monograph, record the second order-derivative spectrum in the range 255 nm to 275 nm of a 0.020 per cent v/v solution of *toluene* and in *methanol* using *methanol* in the reference cell. A small negative extremum (or trough) located between two large negative extrema (or troughs) at about 261 nm and 268 nm should be clearly visible.

**Procedure.** Prepare the solution of the substance under examination, adjust the various instrument settings as stated in the manufacturer's instructions and calculate the amount of the substance under examination as stated in the monograph.

#### 2.4.8. Boiling Range or Temperature and Distillation Range

The boiling or distilling range of a liquid is the temperature interval, corrected for a pressure of 101.3 kPa within which the liquid, or a specified fraction of the liquid, distils under the conditions specified in the test. The lower limit of the range is the temperature indicated by the thermometer when the first drop of condensate leaves the tip of the condenser, and the upper limit is the temperature at which the last drop evaporates from the lowest point in the distillation flask; it may also be the temperature observed when the proportion specified in the individual monograph has been collected.

#### Apparatus

Use an apparatus consisting of the following:

**Distilling flask.** A round-bottomed distilling flask of 200-ml capacity and having a total length of 17 to 19 cm and an inside neck diameter of 20 to 22 mm. Attached about midway on the neck, approximately 12 cm from the bottom of the flask, is a side-arm 10 to 12 cm long and 5mm in internal diameter which is at an angle of  $70^\circ$  to  $75^\circ$  with the lower portion of the neck.

**Condenser.** A straight glass condenser 55 to 60 cm long with a water-jacket about 40 cm long or any other type of condenser having equivalent condensing capacity. The lower end of the condenser may be bent to provide a delivery tube, or it may be connected to a bent adaptor that serves as a delivery tube.

**Receiver.** A 100-ml cylinder graduated in 1-ml sub-divisions.

**Thermometer.** An accurately standardised, partial immersion thermometer having the smallest practical sub-divisions (not greater than  $0.2^\circ$ ). When placed in position, the stem is located in the centre of the neck and the top of the bulb is just below the bottom of the outlet to the side arm.



### Method

If the liquid under examination distils below 80°, cool it to between 10° and 15° before measuring the sample for distillation.

Assemble the apparatus and place in the flask 100 ml of the liquid being examined, taking care not to allow any of the liquid to enter the side-arm. Insert the thermometer and shield the entire heating and flask assembly from external air currents. Add a few pieces of porous material and heat rapidly to boiling using a Bunsen burner (or an electric heater or mantle with arrangement for adjustment of the applied heat) and an asbestos plate pierced by a hole 33 mm in diameter. Record the temperature at which the first drop of distillate falls into the receiver and adjust the rate of heating to obtain a regular distillation rate of 4 to 5 ml per minute. Record the temperature when the last drop of liquid evaporates from the lowest point in the distillation flask or when the specified percentage has distilled over. Correct the observed temperature readings for any variation in the barometric pressure from the normal (101.3 kPa) using the following expression.

$$t_1 = t_2 + K(a - b),$$

- where,  $t_1$  = the corrected temperature,  
 $t_2$  = the observed temperature,  
 $a$  = 101.3, when the barometric pressure is measured in kilopascals (kPa), or 760 when measured in torr,  
 $b$  = the barometric pressure at the time of the determination,  
 $K$  = the correction factor indicated in Table.

Table – Variation of correction factor with temperature.

Boiling range °C	$K_{\text{kPa}}$	$K_{\text{torr}}$
Less than 100	0.30	0.040
100 to 140	0.34	0.045
141 to 190	0.38	0.050
191 to 240	0.41	0.055
More than 240	0.45	0.060

### 2.4.9. Conductivity

The conductivity of a solution ( $K$ ) is the reciprocal of resistivity ( $\rho$ ) which is defined as the quotient of the electric field and the density of the current (flowing in the conducting solution). The resistance  $R$  (in  $\Omega$ ) of a conductor of cross-section  $S$  (in  $\text{cm}^2$ ) and length  $L$  (in cm) is given by the expression  $R = \rho \times L/S$  or  $1/K \times L/S$ ; thus,  $K = 1/R \times L/S$  where,  $L/S$  corresponds to the ideal cell constant.

The unit of conductivity in the International System is the siemens per metre ( $\text{S m}^{-1}$ ). What is generally used in expressing the electrical conductivity of a solution is siemens per centimetre ( $\text{S cm}^{-1}$ ) or microsiemens per centimetre ( $\mu\text{S cm}^{-1}$ ). The resistivity of a solution is expressed in ohm-centimetres ( $\Omega \text{cm}$ ).

Unless otherwise stated, the reference temperature for the expression of conductivity or resistivity is 25°.

**Apparatus.** The apparatus used is a conductivity meter that measures the resistance of the column of liquid between the electrodes of the immersed conductivity cell (the measuring device). The meter is supplied with alternating current and is equipped with a temperature probe and a temperature compensation device. The generally used conductivity cell contains two parallel platinum electrodes coated with platinum black, each with a surface area  $S$ , and separated from the other by a distance  $L$ . The electrodes are protected by a glass tube. Other types of cells may also be used.

#### Procedure

**Determination of the cell constant.** Use a conductivity cell that is appropriate for the conductivity of the solution under examination. A high cell constant is necessary when solutions of high conductivity are tested. Commonly used conductivity cells have cell constants of the order of  $0.1 \text{ cm}^{-1}$ ,  $1 \text{ cm}^{-1}$  and  $10 \text{ cm}^{-1}$ .

Use a certified reference material (such as a solution of potassium chloride) with a conductivity value near the expected value of the solution under examination. Rinse the cell several times with *distilled water* and at least twice with the certified reference material used for the determination of the cell constant of the conductivity cell. Measure the resistance of the conductivity cell using the certified reference material at  $25 \pm 1^\circ$ . The cell constant is given by the expression  $K = R_{\text{cm}} \times K_{\text{cm}}$ , where,  $R_{\text{cm}}$  is the measured resistance in megaohms and  $K_{\text{cm}}$  is the conductivity of the certified reference material solution used, in microsiemens per centimetre.

*NOTE — Other certified reference materials may be used especially for cells having a constant of  $0.1 \text{ cm}^{-1}$ .*

The measured constant  $K$  of the conductivity cell must be within 5 per cent of the value indicated.

If the cell constant is determined at a temperature other than that indicated for the certified reference material, the conductivity value is calculated from the expression:

$$K_t = K_{\text{cm}} \times [1 + \alpha (T - T_{\text{cm}})]$$

Where,  $K_t$  = value of conductivity at the different temperature

$K_{\text{cm}}$  = value of conductivity of the certified reference material



- T = temperature set for calibration  
 $T_{cm}$  = temperature indicated for the certified reference material  
 $\alpha$  = temperature coefficient for the conductivity value of the certified reference material (0.021 for potassium chloride)

**Calibration of meter.** Calibration can be done by replacing the conductivity cell with officially certified precision resistors (accurate to  $\pm 0.1$  per cent of the stated value) or an equally accurate adjustable resistance device to give a predicted instrument response. Each scale on the meter may have to be calibrated prior to use. The instrument must have a minimum resolution of  $0.1 \mu\text{S cm}^{-1}$ .

**Method.** After the apparatus has been calibrated with a certified reference material solution, rinse the conductivity cell several times with *distilled water* and at least twice with the aqueous solution under examination. Carry out successive measurements as described in the individual monograph.

**Water conductivity.** A three-stage method of testing is described for Purified Water and Water for Injections (WFI). Testing at the first stage is usually adequate for Purified Water. Testing at two preliminary stages is given for WFI. If the test conditions and conductivity limits are met at either of these preliminary stages, the water meets the requirements of the test. In such cases proceeding to the third stage may not be necessary. Only in the event of failure at the final stage is the sample to be considered as not complying with the requirements of the test.

Stage 1 of the procedure may alternatively be performed on-line (with suitable modifications of the first step) with instrumentation that has been appropriately calibrated, whose cell constants have been accurately determined, and whose temperature compensation has been disabled. Prior to testing it must be ensured that such instrumentation has been suitably located and fitted in the water system.

### Procedure

#### Stage 1.

1. Measure the temperature of the water using a nontemperature-compensated conductivity reading. The measurement may be done in a suitable container or as an on-line determination.
2. Using Table 1 find the temperature value that is not greater than the measured temperature and read the corresponding conductivity value that becomes the limit (*Do not interpolate*).
3. If the measured conductivity is not greater than the table value, the water meets the requirements of the test. If the conductivity is higher than the table value, proceed with testing at stage 2.

Table 1

Temperature (°)	Purified Water Conductivity ( $\mu\text{S cm}^{-1}$ )	Water for Injections Conductivity ( $\mu\text{S cm}^{-1}$ )
0	2.4	0.6
5	–	0.8
10	3.6	0.9
15	–	1.0
20	4.3	1.1
25	5.1	1.3
30	5.4	1.4
35	–	1.5
40	6.5	1.7
45	–	1.8
50	7.1	1.9
55	–	2.1
60	8.1	2.2
65	–	2.4
70	9.1	2.5
75	9.7	2.7
80	9.7	2.7
85	–	2.7
90	9.7	2.7
95	–	2.9
100	10.2	3.1

#### Stage 2.

4. Transfer a sufficient amount of water (100 ml or more) to a suitable container, and stir the test sample. Adjust the temperature, if necessary, and while maintaining it at  $25 \pm 1^\circ$ , begin vigorously agitating the sample while periodically observing the conductivity. When the change in conductivity (due to uptake of atmospheric carbon dioxide) is less than  $0.1 \mu\text{S cm}^{-1}$  per 5 minutes, note the conductivity.
5. If the conductivity is not greater than  $2.1 \mu\text{S cm}^{-1}$ , the water under examination meets the requirements of the test. If the conductivity is greater than  $2.1 \mu\text{S cm}^{-1}$ , proceed with the testing at stage 3.

#### Stage 3.

6. Perform this test within approximately 5 minutes of the conductivity determination in step 5 under stage 2, while maintaining the sample temperature at  $25 \pm 1^\circ$ . Add a recently prepared saturated solution of *potassium chloride* to the test sample (0.3 ml per 100 ml of the test sample), and determine the pH (2.4.24) to the nearest 0.1 pH unit.

7. Using Table 2, determine the conductivity limit at the measured pH value in step 6. If the measured conductivity in step 4 under stage 2 is not greater than the conductivity requirements for the pH determined, the water under examination meets the requirements of the test. If either the measured conductivity is greater than this value or the pH is outside the range of 5.0 to 7.0, the water under examination does not meet the requirements of the test.

Table 2

pH	Conductivity ( $\mu\text{s}\cdot\text{cm}^{-1}$ )
5.0	4.7
5.1	4.1
5.2	3.6
5.3	3.3
5.4	3.0
5.5	2.8
5.6	2.6
5.7	2.5
5.8	2.4
5.9	2.4
6.0	2.4
6.1	2.4
6.2	2.5
6.3	2.4
6.4	2.2
6.5	2.2
6.6	2.2
6.7	2.6
6.8	3.1
6.9	3.8
7.0	4.6

### 2.4.10. Congealing Range or Temperature

The congealing temperature is that point at which there exists a mixture of the liquid (fused) phase of a substance and a small but increasing proportion of the solid phase. It is distinct from the freezing point which is the temperature at which the liquid and solid phases of a substance are in equilibrium. In certain cases, this may happen over a range of temperatures.

The temperature at which a substance solidifies upon cooling is a useful index of its purity if heat is liberated when solidification takes place.

The following method is applicable to substances that melt between  $-20^{\circ}$  and  $150^{\circ}$ .

#### Apparatus

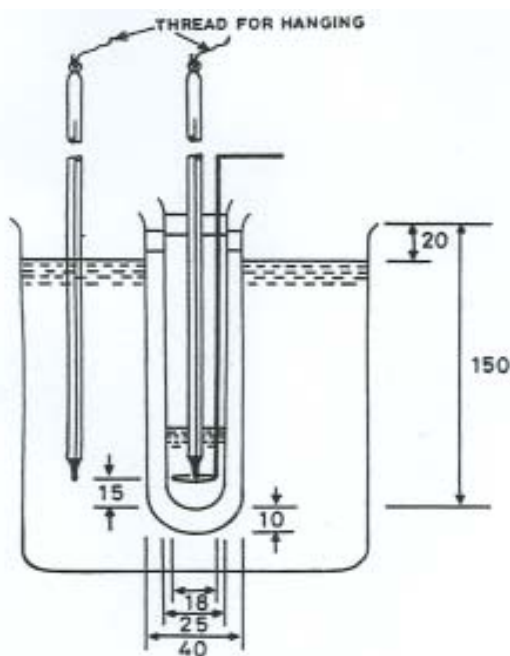

Fig. 2.4.10-1: Apparatus for Determination of Congealing Range or Temperature

A test-tube (about 150 mm x 25 mm) placed inside another test-tube (about 160 mm x 40 mm) the inner tube is closed by a stopper that carries a stirrer and a thermometer (about 175 mm long and with  $0.2^{\circ}$  graduations) fixed so that the bulb is about 15 mm above the bottom of the tube. The stirrer is made from a glass rod or other suitable material formed at one end into loop of about 18 mm overall diameter at right angles to the rod. The inner tube with its jacket is supported centrally in a 1-litre beaker containing a suitable cooling liquid to within 20 mm of the top. The thermometer is supported in the cooling bath (see Fig. 2.4.10-1).

#### Method

Melt the substance, if a solid, at a temperature not more than  $20^{\circ}$  above its expected congealing point, and pour it into the inner test-tube to a height of 50 to 57 mm. Assemble the apparatus with the bulb of the thermometer immersed half-way between the top and bottom of the sample in the test-tube. Fill the bath to almost 20 mm from the top of the tube with a suitable fluid at a temperature  $4^{\circ}$  to  $5^{\circ}$  below the expected congealing point. If the substance is a liquid at room temperature, carry out the determination using bath temperature about  $15^{\circ}$  below the expected congealing point. When the sample has cooled to about  $5^{\circ}$  above its expected congealing point stir it continuously by moving the loop up and down between the top and bottom of the sample at a regular rate of 20 complete cycles per minute. If necessary, congealation may be induced by scratching the inner walls of

the test-tube with the thermometer or by introducing a small amount of the previously congealed substance under examination. Pronounced supercooling may result in deviation from the normal pattern of temperature changes. If it happens, repeat the test introducing small fragments of the solid substance under examination at 1° intervals when the temperature approaches the expected congealing point.

Record the reading of the thermometer every 30 seconds and continue stirring only so long as the temperature is falling. Stop the stirring when the temperature is constant or starts to rise slightly. Continue recording the temperature for at least 3 minutes after the temperature again begins to fall after remaining constant.

The congealing point will be the mean of not less than four consecutive readings that lie within a range of 0.2°.

### 2.4.11. Freezing Point

The freezing point is the maximum temperature occurring during the solidification of a supercooled liquid.

#### Apparatus

The apparatus and its dimensions are as shown in Fig. 2.4.10-1.

#### Method

Place a quantity of the substance under examination in the inner tube such that the thermometer bulb is well covered and determine the approximate freezing point by cooling rapidly. Place the inner tube in a bath about 5° above the approximate freezing point until all but the last traces of crystals are melted. Fill the beaker with water or a saturated solution of sodium chloride at a temperature about 5° lower than the approximate freezing point, assemble the apparatus, ensuring that some seed crystals are present, and stir thoroughly until solidification takes place. The highest temperature observed during solidification of the substance is regarded as the freezing point of the substance.

### 2.4.12. Electrophoresis

Electrophoresis is a physical method of analysis based on the migration of electrically charged proteins, colloids, molecules or other particles dissolved or dispersed in an electrolyte solution in the direction of the electrode bearing the opposite polarity when an electric current is passed through it. In gel electrophoresis, the movements of the particles are retarded by interactions with the surrounding gel matrix, which acts as a molecular sieve. The opposing interactions of the electrical force and molecular sieving result in differential migration rates according to sizes, shapes and charges of particles. Due to differences in the physico-chemical properties, different macromolecules of a mixture migrate at different speeds during

electrophoresis and will thus be separated into discrete fractions. Separations may be conducted in systems without support phases (such as free solution separation in capillary electrophoresis) or in stabilising media such as thin-layer plates, films or gels.

The electrophoretic mobility is the rate of movement in metres per second of the charged particles under the action of an electric field of 1 volt per metre and is expressed in square metres per volt second. For practical reasons it is given in square centimetres per volt second  $\text{cm}^2 \text{V}^{-1}\text{S}^{-1}$ . The mobility is specific for a given electrolyte under precisely determined operational conditions.

Depending on the method used, the electrophoretic mobility is either measured directly or compared with that of a reference substance.

Based upon the type of apparatus used, electrophoretic methods may be divided into two categories, one called free or moving boundary and the other called zone electrophoresis (using a supporting medium).

#### Moving Boundary Electrophoresis

This method is chiefly employed with substances of high relative molecular weight and low diffusibility. In the method a buffered solution of proteins in a U-shaped cell is subjected to an electric current which causes the proteins to form a series of layers in order of decreasing mobility, which are separated by boundaries. Only a part of the fastest moving protein is physically separated from the other proteins, but examination of the moving boundaries by physical processes such as refractometry or conductimetry helps to locate the boundaries and also provides data for calculation of mobilities and information on the qualitative and quantitative composition of the protein mixture. The operating conditions must be such as to make it possible to determine as many boundaries as there are components.

#### Zone Electrophoresis

This method requires the use of small samples only.

In zone electrophoresis, the sample is introduced as a narrow zone or spot in a column, slab or film of buffer. Migration of the components as narrow zones permits their complete separation. Remixing of the separated zones by thermal convection is prevented by stabilising the electrolyte in a porous matrix such as powdered solid, or a fibrous material such as paper, foil or gel such as agar, starch or polyacrylamide.

The rate of migration depends on four main factors viz. the mobility of the charged particle, the electro-osmotic flow, the evaporation flow, and the strength of the field. It is necessary to operate under clearly defined experimental conditions and to use, wherever possible, reference substances.

### Apparatus

The apparatus consists essentially of the following:

- (1) An appropriate power source supplying a direct current and provided with means for indicating and controlling either the output voltage or the current consumption as appropriate; the output may be stabilised suitably.
- (2) An electrophoresis chamber which is usually rectangular and made of glass or rigid plastic, with two separate troughs, the anodic and the cathodic, containing the electrolyte solution. In one compartment of each trough is immersed an electrode; these are connected by means of an appropriately isolated circuit to the corresponding terminal of the power supply to form the anode and the cathode. The level of the liquid in the two troughs is kept equal to prevent siphoning. Contact between the inner and outer compartments of each double trough is made either by means of "bridges" of electrophoresis paper (suitable filter paper that has been washed chromatographically for 16 hours with a mixture of 20 volumes of acetone and 10 volumes of water, dried and cut into strips of appropriate size) or by perforating the central portion with several holes or by any other means. The electrophoresis chamber is fitted with an airtight lid which maintains a moisture-saturated atmosphere during operation and reduces evaporation of the solvent. A safety device may be used to cut off the power when the lid is removed. If the electrical power measured across the strip exceeds 10 W, it is advisable to cool the support.
- (3) A support-carrying device suitable for the type of electrophoresis to be carried out.
  - (a) *For strip electrophoresis* — The supporting strip, previously wetted with the same conducting solution and dipping at each end into that compartment of each trough that does not contain the electrode, is appropriately tightened and fixed on to a suitable carrier designed to prevent diffusion of the conducting electrolyte, such as a horizontal frame, inverted-V stand or a uniform surface with contact points at suitable intervals.
  - (b) *For gel electrophoresis* — The device consists essentially of a glass plate over the whole surface of which is deposited a firmly adhering layer of gel of uniform thickness. The connection between the gel and the conducting solution is effected in various ways according to the type of apparatus used. Precautions are to be taken to avoid condensation of moisture or drying of the solid layer.
- (4) A measuring device or means of detection.

### Method

Introduce the electrolyte solution into the electrode compartments. Place the support suitably impregnated with

electrolyte solution in the chamber under the conditions prescribed for the type of apparatus used. Locate the starting line and apply the sample. Apply the electric current for the prescribed time. Switch off the current and remove the support from the chamber, dry and visualise.

*CAUTION* — Voltages used in electrophoresis can deliver a lethal shock. The equipment, with the exception of the power supply, should be enclosed in either a grounded metal case or a case of insulating material. High-voltage cables should be such that the central conductor is completely shielded and the base of the apparatus should be grounded metal or contain a grounded metal rim so constructed that any leakage of electrolyte will produce a short-cutting of the power supply before the electrolyte can flow beyond the protective enclosure.

### Cellulose Acetate Electrophoresis

Use Method I unless otherwise directed.

#### Method I

Fill the troughs of the apparatus with the electrolyte solution specified in the monograph. Immerse cellulose acetate foil of suitable dimensions for 5 minutes in the same solution and press the strips dry between filter paper. Apply separately to the foil at points 1 cm from the anode edge and 2.5 cm apart 1  $\mu$ l of each of the solutions prescribed. Adjust the voltage to that given in the monograph and allow electrophoresis to proceed for the specified time. Press the strips dry and immerse in a solution prepared by dissolving 1g of *potassium ferricyanide* in 50 ml of *water* and adding 2 ml of a saturated solution of *ferric chloride*. Wash with a 5 per cent v/v solution of *phosphoric acid* until the background is as pale as possible and finally wash with *water*. Examine the electropherogram.

#### Method II

Fill the troughs of the apparatus with *mixed barbitone buffer pH 8.6*. Use a separate strip of cellulose acetate for each solution prescribed in the monograph and apply either 2.5  $\mu$ l of the solution as a 10-mm band or, if narrower strips are used, 0.25  $\mu$ l of the solution per mm of strip width. Apply a suitable electric field such that the most rapid band migrates at least 30 mm. Stain the strips with a 0.5 per cent w/v solution of *naphthalene black 12B* in a mixture of 90 volumes of *methanol* and 10 volumes of 5M *acetic acid* for 5 minutes and then decolorise with a mixture of 90 volumes of *methanol* and 10 volumes of *acetic acid* so that the background is just free of colour. Wash the strips with a mixture of 81 volumes of *methanol* and 19 volumes of 5 M *acetic acid* until the background is as transparent as possible. Measure the absorbance of the bands at about 600 nm in an instrument having a linear response over the range of at least 0 to 3 (2.4.7). Calculate the result as the mean of three measurements of each strip.



### Polyacrylamide Rod Gel Electrophoresis

#### Apparatus

This consists of two buffer solution reservoirs made of suitable material such as poly (methyl methacrylate) and mounted vertically one above the other. Each reservoir is fitted with a platinum electrode. The electrodes are connected to a power supply operating either at constant current or at constant voltage. The apparatus has in the base of the upper reservoir a number of holders equidistant from the electrode.

#### Method

*Degas the solutions before polymerisation and use the gels immediately after preparation.*

Prepare the gel mixture as prescribed and pour into suitable glass tubes, stoppered at the bottom, to an equal height in each tube and to about 1 cm from the top, ensuring that no air bubbles are trapped in the tubes. Cover the gel mixture with a layer of *water* to exclude air and allow to set. A gel is usually formed in about 30 minutes and a sharp interface between the gel and the water layer should be formed. Remove the water layer. Fill the lower reservoir with the prescribed buffer solution and remove the stoppers from the tubes. Fit the tubes into the holders of the upper reservoir and adjust so that the bottom of the tubes are immersed in the buffer solution in the lower reservoir. Carefully fill the tubes with the prescribed buffer solution.

Prepare the test and reference solutions containing the prescribed marker dye and make them dense by dissolving in them *sucrose* for example. Apply the solutions to the surface of a gel using a different tube for each solution. Add the same buffer to the upper reservoir. Connect the electrodes to the power supply and allow electrophoresis to proceed at the prescribed temperature and using the prescribed constant voltage or current. Switch off the power supply when the marker dye has migrated almost into the lower reservoir. Immediately remove each tube from the apparatus and extrude the gel. Locate the position of the bands in the electropherogram as prescribed.

#### Sodium Dodecyl Sulphate Polyacrylamide gel Electrophoresis (SDS-PAGE)

This method is used for the qualitative characterisation of proteins in biological preparations, for control of purity, assessments of the homogeneity of proteins and quantitative determinations. It can be adopted for the routine estimation of protein subunit molecular masses and for determining the subunit compositions of purified proteins.

#### *Denaturing polyacrylamide gel electrophoresis*

Denaturing polyacrylamide gel electrophoresis using sodium dodecyl sulphate (SDS-PAGE) is the most common mode of

electrophoresis used in assessing the pharmaceutical quality of protein products and will be the focus of the example method. Typically, analytical electrophoresis of proteins is carried out in polyacrylamide gels under conditions that ensure dissociation of the proteins into their individual polypeptide subunits and that minimise aggregation. Most commonly, the strongly anionic detergent sodium dodecyl sulphate (SDS) is used in combination with heat to dissociate the proteins before they are loaded on the gel. The denatured polypeptides bind to SDS, become negatively charged and exhibit a consistent charge-to-mass ratio regardless of protein type. Because the amount of SDS bound is almost always proportional to the molecular mass of the polypeptide and is independent of its sequence, SDS-polypeptide complexes migrate through polyacrylamide gels with mobilities dependent on the size of the polypeptide.

The electrophoretic mobilities of the resultant detergent-polypeptide complexes all assume the same functional relationship to their molecular masses. Migration of SDS complexes is toward the anode in a predictable manner, with low-molecular-mass complexes migrating faster than larger ones. The molecular mass of a protein can therefore be estimated from its relative mobility in calibrated SDS-PAGE and the occurrence of a single band in such a gel is a criterion of purity.

Modifications to the polypeptide backbone, such as *N*- or *O*-linked glycosylation, however, have a significant impact on the apparent molecular mass of a protein since SDS does not bind to a carbohydrate moiety in a manner similar to a polypeptide. Thus, a consistent charge-to-mass ratio is not maintained. The apparent molecular mass of proteins having undergone post-translational modifications is not a true reflection of the mass of the polypeptide chain.

**Reducing conditions.** Polypeptide subunits and three-dimensional structure is often maintained in proteins by the presence of disulphide bonds. A goal of SDS-PAGE analysis under reducing conditions is to disrupt this structure by reducing disulphide bonds. Complete denaturation and dissociation of proteins by treatment with 2-mercaptoethanol or dithiothreitol (DTT) will result in unfolding of the polypeptide backbone and subsequent complexation with SDS. In these conditions, the molecular mass of the polypeptide subunits can be calculated by linear regression in the presence of suitable molecular-mass standards.

**Non-reducing conditions.** For some analyses, complete dissociation of the protein into subunit peptides is not desirable. In the absence of treatment with reducing agents such as 2-mercaptoethanol or DTT, disulphide covalent bonds remain intact, preserving the oligomeric form of the protein. Oligomeric SDS-protein complexes migrate more slowly than their SDS-polypeptide subunits. In addition, non-reduced proteins may not be completely saturated with SDS and, hence,



may not bind the detergent in a constant mass ratio. This makes molecular-weight determinations of these molecules by SDS-PAGE less straightforward than analyses of fully denatured polypeptides, since it is necessary that both standards and unknown proteins be in similar configurations for valid comparisons. However, the staining of a single band in such a gel is a criterion of purity.

### ***Characteristics of discontinuous buffer system gel electrophoresis***

The most popular electrophoretic method for the characterisation of complex mixtures of proteins involves the use of a discontinuous buffer system consisting of two contiguous, but distinct gels: a resolving or separating (lower) gel and a stacking (upper) gel. The two gels are cast with different porosities, pH, and ionic strengths. In addition, different mobile ions are used in the gel and electrode buffers. The buffer discontinuity acts to concentrate large volume samples in the stacking gel, resulting in improved resolution. When power is applied, a voltage drop develops across the sample solution that drives the proteins into the stacking gel. Glycinate ions from the electrode buffer follow the proteins into the stacking gel. A moving boundary region is rapidly formed with the highly mobile chloride ions in the front and the relatively slow glycinate ions in the rear. A localised high-voltage gradient forms between the leading and trailing ion fronts, causing the SDS-protein complexes to form into a thin zone (stack) and migrate between the chloride and glycinate phases. Within broad limits, regardless of the height of the applied sample, all SDS-proteins condense into a very narrow region and enter the resolving gel as a well-defined, thin zone of high protein density. The large-pore stacking gel does not retard the migration of most proteins and serves mainly as an anticonvective medium. At the interface of the stacking and resolving gels, the proteins experience a sharp increase in retardation due to the restrictive pore size of the resolving gel. Once in the resolving gel, proteins continue to be slowed by the sieving of the matrix. The glycinate ions overtake the proteins, which then move in a space of uniform pH formed by the tris (hydroxymethyl) aminomethane and glycine. Molecular sieving causes the SDS-polypeptide complexes to separate on the basis of their molecular weights.

### **Method**

Commercially available ready-to-use gels may be used for the test.

Mount the gel in the electrophoresis apparatus. Add the electrophoresis buffers to the top and bottom reservoirs. Remove any bubbles that become trapped at the bottom of the gel between the glass plates. This is best done with a bent hypodermic needle attached to a syringe. Never pre-run the gel before loading the samples, since this will destroy the

discontinuity of the buffer systems. Before loading the sample, carefully rinse the slot with *SDS-PAGE running buffer*. Prepare the test and reference solutions in the recommended sample buffer and treat as specified in the individual monograph. Apply the appropriate volume of each solution to the stacking gel wells.

Start the electrophoresis using the conditions recommended by the manufacturer of the equipment. Manufacturers of SDS-PAGE equipment may provide gels of different surface area and thickness. Electrophoresis running time and current/voltage may need to vary as described by the manufacturer of the apparatus in order to achieve optimum separation. Check that the dye front is moving into the resolving gel. When the dye is reaching the bottom of the gel, stop the electrophoresis. Remove the gel assembly from the apparatus and separate the glass plates. Remove the spacers, cut off and discard the stacking gel and immediately proceed with staining.

### ***Detection of proteins in gels***

Coomassie staining is the most common protein staining method with a detection level of the order of 1 µg to 10 µg of protein per band. Silver staining is the most sensitive method for staining proteins in gels and a band containing 10 ng to 100 ng can be detected.

All the steps in gel staining are done at room temperature with gentle shaking (e.g. on an orbital shaker platform) in any convenient container. Gloves must be worn when staining gels, since fingerprints will stain.

**Coomassie staining.** Immerse the gel in a large excess of *Coomassie staining solution* and allow to stand for at least 1 hour. Remove the staining solution.

Destain the gel with a large excess of *destaining solution*. Change the destaining solution several times, until the stained protein bands are clearly distinguishable on a clear background. The more thoroughly the gel is destained, the smaller is the amount of protein that can be detected by the method. Destaining can be speeded up by including a few grams of anion-exchange resin or a small sponge in the destaining solution.

*NOTE* — the acid-alcohol solutions used in this procedure do not completely fix proteins in the gel. This can lead to losses of some low-molecular-mass proteins during the staining and destaining of thin gels. Permanent fixation is obtainable by allowing the gel to stand in a mixture of 1 volume of trichloroacetic acid, 4 volumes of methanol and 5 volumes of water for 1 hour before it is immersed in the *Coomassie staining solution*.

**Silver staining.** Immerse the gel in a large excess of *fixing solution* and allow to stand for 1 hour. Remove the fixing solution, add fresh fixing solution and incubate either for at

least 1 hour or overnight, if convenient. Discard the fixing solution and wash the gel in a large excess of *water* for 1 hour. Soak the gel for 15 minutes in a 1 per cent v/v solution of *glutaraldehyde*. Wash the gel twice for 15 minutes in a large excess of *water*. Soak the gel in fresh *silver nitrate reagent* for 15 minutes, in darkness. Wash the gel three times for 5 min in a large excess of *water*. Immerse the gel for about 1 minute in *developer solution* until satisfactory staining has been obtained. Stop the development by incubation in the *blocking solution* for 15 minutes. Rinse the gel with *water*.

#### **Drying of stained SDS polyacrylamide gels**

Depending on the staining method used, gels are treated in a slightly different way. For Coomassie staining, after the destaining step, allow the gel to stand in a 10 per cent w/v solution of *glycerol* for at least 2 hours (overnight incubation is possible). For silver staining, add to the final rinsing a step of 5 minutes in a 2.0 per cent w/v solution of *glycerol*.

Immerse two sheets of porous cellulose film in *water* and incubate for 5 minutes to 10 minutes. Place one of the sheets on a drying frame. Carefully lift the gel and place it on the cellulose film. Remove any trapped air bubbles and pour a few millilitres of *water* around the edges of the gel. Place the second sheet on top and remove any trapped air bubbles. Complete the assembly of the drying frame. Place in an oven or leave at room temperature until dry.

#### **Molecular weight determination**

Molecular weights of proteins are determined by comparison of their mobilities with those of several marker proteins of known molecular weight. Mixtures of proteins with precisely known molecular weights blended for uniform staining are available for calibrating gels. They are obtainable in various molecular weight ranges. Concentrated stock solutions of proteins of known molecular weight are diluted in the appropriate sample buffer and loaded on the same gel as the protein sample to be studied.

Immediately after the gel has been run, the position of the bromophenol blue tracking dye is marked to identify the leading edge of the electrophoretic ion front. This can be done by cutting notches in the edges of the gel or by inserting a needle soaked in India ink into the gel at the dye front. After staining, measure the migration distances of each protein band (markers and unknowns) from the top of the resolving gel. Divide the migration distance of each protein by the distance travelled by the tracking dye. The normalised migration distances so obtained are called the relative mobilities of the proteins (relative to the dye front) and conventionally denoted as  $R_f$ . Construct a plot of the logarithm of the relative molecular weights ( $M_r$ ) of the protein standards as a function of the  $R_f$  values. Note that the graphs are slightly sigmoid. Unknown molecular weights can be estimated by linear regression

analysis or interpolation from the curves of  $\log M_r$  against  $R_f$  as long as the values obtained for the unknown samples are positioned along the linear part of the graph.

#### **Validation of the test**

The test is not valid unless the proteins of the molecular weight marker are distributed along 80 per cent of the length of the gel and over the required separation range (e.g. the range covering the product and its dimer or the product and its related impurities) the separation obtained for the relevant protein bands shows a linear relationship between the logarithm of the molecular weight and the  $R_f$ . Additional validation requirements with respect to the solution under test may be specified in individual monographs.

#### **Quantification of impurities**

Where the impurity limit is specified in the individual monograph, a reference solution corresponding to that level of impurity should be prepared by diluting the test solution. For example, where the limit is 5 per cent, a reference solution would be a 1:20 dilution of the test solution. No impurity (any band other than the main band) in the electropherogram obtained with the test solution may be more intense than the main band obtained with the reference solution.

Under validated conditions impurities may be quantified by normalisation to the main band using an integrating densitometer. In this case, the responses must be validated for linearity.

### **2.4.13. Gas Chromatography**

Gas Chromatography (GC), also known as Gas Liquid Chromatography (GLC), is a technique for separation of mixtures into components by a process which depends on the redistribution of the components between a stationary phase or support material in the form of a liquid, solid or combination of both and a gaseous mobile phase. It is applicable to substances or their derivatives which are volatilized under the temperatures employed. GC is based on mechanisms of adsorption, mass distribution or size exclusion.

#### **Apparatus**

The apparatus consists of an injector, a chromatographic column contained in an oven, a detector and a data acquisition system. The carrier gas flows through the column at a controlled rate or pressure and then through the detector.

**Injectors.** Direct injections of solutions are the usual mode of sample introduction unless otherwise prescribed in the monograph. Injection may be carried out either directly at the head of the column using a syringe or an injection valve, or into a vaporization chamber which may be equipped with a stream splitter.

Injections of vapour phase may also be effected by static or dynamic head space injection systems. Dynamic head space (purge and trap) injection system include a sparging device by which volatile substances from a solution are swept into an adsorbent column maintained a low temperature. Retained substances are then desorbed into the mobile phase by rapid heating of the adsorbent column.

Static head space injection systems include thermostatically controlled sample heating chamber in which closed vials containing solid or liquid samples are placed for a fixed period of time to allow the volatile components of the sample to reach equilibrium between the non-gaseous phase and the vapour phase. After equilibrium has been established, a pre-determined quantity of the head space vapour from the vial is automatically introduced into the gas chromatograph either by a heated syringe or a transfer line and sample loop.

**Stationary Phases.** Stationary phases are contained inside the column. A GC column can be:

- A) a fused silica capillary column whose wall is coated with the stationary phase.
- B) a metallic or glass column packed with inert particles impregnated with the stationary phase.
- C) a metallic or glass column packed with solid stationary phase.

A wide range of chemical substances are used as stationary phase in GC. These include polyethylene glycols, high molecular weight esters and amides, hydrocarbons, silicon gums and fluids (polysiloxanes substituted with methyl, phenyl, cyano, vinyl or fluoroalkyl groups or mixtures of these) and solid adsorbents like micro porous cross-linked polyaromatic beads, molecular sieves etc.

Capillary columns can be of 0.1 mm to 0.53 mm in internal diameter and 10 meter to 100 meter in length. The liquid or solid stationary phase may be chemically bonded to the inner surface of the tubing with a coating thickness of 0.1 micron to 5.0 microns.

Packed columns, made of glass or metal, are usually 1 meter to 3 meter in length with an internal diameter of 2 mm to 4 mm.

Support materials must be inert to avoid peak tailing. The reactivity of support materials can be reduced by silanising prior to coating with liquid phase. Acid washed, flux-calcinated diatomaceous earth is often used as support material. The support materials are available in various particle sizes, the most commonly used ones in the range of 100 to 120 mesh.

**Mobile phases.** Mobile phases that are employed in GC are inert gases. The commonly used gases are Nitrogen, Hydrogen and Helium. The source of carrier gas can be a pressurized cylinder or a gas generator which can provide a continuous flow of the gas. The purity of the gas should be minimum

99.99 per cent. The gas should pass through a purification panel having suitable filters for the removal of residual moisture, oxygen and hydrocarbons before entering the GC. The pressure and flow rate of the carrier gas should be adjusted to get optimum separation of sample components.

**Detectors.** Flame ionization detectors are usually used. Additional detectors which may be used include: thermal conductivity, electron capture, nitrogen-phosphorus, flame photometric and mass spectrometric depending upon the purpose of the analysis.

**Method.** Equilibrate the column, the injector and the detector (flame ionisation, unless otherwise stated in the individual monograph) at the specified temperatures and flow rates until a stable base line is obtained. Prepare the test and reference solutions as prescribed in the monograph. The solutions must be free from solid particles. Using the solution of the reference substance determine experimentally suitable instrument settings and volumes of solutions to be injected to produce an adequate response. Inject the selected volumes of the solutions prescribed in the monograph and record the resulting chromatograms. Repeat the determinations to ensure a consistent response. Determine the peak areas or peak heights corresponding to the peaks of interest. In determinations requiring temperature programming, peak areas should be considered. From the values obtained, calculate the content of the components being determined.

**Normalization.** Where reference is made to normalization for the estimation of one or more components, the total area of the peak or peaks due to the components is expressed as a percentage of the sum of the areas of all the peaks derived from the substance being examined.

**Internal Standard.** Where reference is made to internal standard method for the estimation of one or more components, a suitable internal standard should be selected for the purpose. The selected internal standard should not contain any impurity that is likely to interfere in the determination described in the monograph.

### Performance

**Resolution.** Unless otherwise stated in the monograph, the Resolution factor,  $R_s$ , between measured peaks on the chromatogram must be greater than 1.0 and is defined by the expression:

$$R_s = \frac{1.18 (t_{r2} - t_{r1})}{W_{h1} + W_{h2}}$$

$t_{r1}$  and  $t_{r2}$  = retention times or distances along the baseline from the point of injection to the perpendiculars dropped from the maxima of 2 adjacent peaks.  $t_{r2} > t_{r1}$

$w_{h1}$  and  $w_{h2}$  = peak widths at half height.

A resolution greater than 1.5 corresponds to baseline separation. The values of  $t_{r1}$ ,  $t_{r2}$ ,  $w_{h1}$  and  $w_{h2}$  must be expressed in the same unit of measurement.

*Symmetry factor.* The symmetry factor or tailing factor of a peak is calculated from the expression:

$$As = \frac{w_{0.05}}{2d}$$

where,  $w_{0.05}$  = width of the peak at one-twentieth of the peak height,

$d$  = distance between the perpendicular dropped from the peak maximum and the leading edge of the peak at one-twentieth of the peak height.

A value of 1.0 signifies complete or ideal symmetry.

*Column efficiency.* When column efficiency is stated in the monograph, it is defined in terms of the number of theoretical plates,  $N$ , by the expression :

$$N = 5.54 (t_r / w_h)^2$$

where,  $t_r$  = retention time or distance along the baseline from the point of injection to the perpendicular dropped from the maximum of the peak corresponding to the component,

$w_h$  = width of the peak at half height.

The apparent number of theoretical plates varies with the sample component as well as with the column.

*Capacity factor or mass distribution ratio.* The capacity factor,  $k'$  also known as mass distribution ratio,  $D_m$  is defined as:

$$D_m = \frac{\text{amount of solute in stationary phase}}{\text{amount of solute in mobile phase}}$$

$$= Kc (V_s / V_m),$$

where,  $Kc$  = equilibrium distribution coefficient

$V_s$  = volume of stationary phase

$V_m$  = volume of mobile phase.

The capacity factor of a component may be calculated from the chromatogram using the equation:

$$K' = \frac{t_R - t_M}{t_M}$$

where,  $t_R$  = retention time or distance along the baseline from the point of injection to the perpendicular dropped from the maximum of the peak corresponding to the component,

$t_M$  = time or distance along the baseline from the point of injection to the perpendicular dropped from the maximum of the peak corresponding to an unretained peak.

*Relative retention.* Absolute retention time of a compound may vary depending upon column and analysis conditions. Comparisons are normally made in terms of relative retention,  $a$ , which is calculated from the expression:

$$a = \frac{t_{R2} - t_M}{t_{R1} - t_M}$$

where,  $t_{R2}$  = retention time of the peak of interest,

$t_{R1}$  = retention time of the reference peak,

$t_M$  = hold-up time: time or distance along the baseline from the point of injection to the perpendicular dropped from the maximum of the peak corresponding to an unretained peak.

Where the value of  $t_M$  is small, the relative retention time,  $Rr$ , may be estimated from the expression:

$$Rr = t_{R2} / t_{R1}$$

*Signal to noise ratio.* The signal-to- noise ratio is determined from the expression:

$$S/N = 2H / h$$

where,  $H$  = height of the peak corresponding to the component concerned, in the chromatogram obtained with the prescribed reference solution, measured from the maximum of the peak to the extrapolated baseline of the signal observed over a distance equal to 20 times the width at half-height.

$h$  = range of the background noise in a chromatogram obtained after injection of a blank, observed over a distance equal to 20 times the width at half-height of the peak in the chromatogram obtained with the prescribed reference solution and , if possible, situated equally around the place where this peak would be found.

*System suitability.* Unless otherwise stated in the monograph, the maximum permitted relative standard deviation for replicate injections of the prescribed reference solution does not exceed 2 per cent. This requirement applies only to assays.

#### Adjustment to chromatographic conditions

Adjustments may be made to the parameters of the test as given below in order to satisfy the system suitability criteria without fundamentally modifying the method.



*Stationary phase.*

- column length:  $\pm 70$  per cent,
- column internal diameter:  $\pm 50$  per cent,
- particle size: reduction of not more than 50 per cent, no increase,
- film thickness: - 50 per cent to + 100 per cent.

*Flow rate.*  $\pm 50$  per cent.

*Temperature.*  $\pm 10$  per cent.

*Injection volume.* May be decreased provided detection and repeatability are satisfactory.

**Static head – space gas chromatography**

Static head-space gas chromatography is a technique suitable for separating and determining volatile compounds present in non-volatile solid or liquid samples. The method is based on the analysis of the vapour phase in equilibrium with the solid or liquid phase.

**Apparatus**

The apparatus consists of a gas chromatograph connected to a head space sampler intended to introduce the vapour in the GC column. The sample to be analyzed is introduced into a glass container fitted with a suitable stopper. The container is placed in a thermostatically controlled chamber at a temperature set according to the substance under examination. The sample is held at this temperature long enough to allow equilibrium to be established between the solid or liquid phase and the vapour phase. After the equilibration period, a portion of the vapour phase can be transferred to the GC column either by a heated syringe or with the help of a transfer line and fixed volume loop. Using the reference preparations, determine suitable instrument settings to produce an adequate response.

**2.4.14. Liquid Chromatography**

Liquid chromatography (LC) is a separation technique based on the difference in the distribution of components between two non-miscible phases in which liquid mobile phase elutes through a stationary phase in a column. The three forms of high performance liquid chromatography most often used are based on mechanism of partition, adsorption and ion exchange.

Ion exchange chromatography, also referred to as ion chromatography, is an analytical technique for the separation and determination of ionic solutes i.e. inorganic cations, inorganic anions, low molecular weight (water soluble) organic acids and bases etc. The separation of ionic solutes takes place on the basis of ion exchange on stationary phases with charged functional groups. The functional groups typically are quaternary ammonium groups for anion exchange and negatively charged groups like sulphonates for cation exchange. The corresponding counter ions are located in

vicinity of the functional groups and can be exchanged with other ions of the same charge in the mobile phase. Thus, various ionic components of the sample can be separated based on their differential affinities towards the immobilized stationary and the liquid mobile phase.

The combination of ion exchange columns with conductivity detection with or without chemical suppression represents the most important and popular type of ion chromatography. In the technique with chemical suppression, the conductivity of the ionic mobile phase is suppressed both chemically and electronically. In case of technique without chemical suppression, the conductivity of mobile phase is suppressed only electronically.

In addition, size exclusion and stereochemical interaction phenomena are also used for separation.

**Apparatus**

A pumping system, an injector, a chromatographic column with or without a column temperature controller, a detector and a data acquisition system (a computer, an integrator or a chart recorder) are the essential components of the equipment. For ion exchange chromatography a suppressor column is installed between main column and detector. The mobile phase is supplied from one or several reservoirs and flows through the column, usually at a constant rate, and then through the detector. Any part of the system that is in contact with the mobile phase should be constructed of materials inert to corrosive components of the mobile phase. The entire system dead volume has to be kept at the minimum. The tubing length and diameter of plumbing between the injector, column and detector has to be kept at the minimum. Higher volumes in these connections lead to increased dispersion and tailing of peaks.

**Pumping systems**

The pumping systems deliver metered amounts of the mobile phase from the solvent reservoirs to the column through high-pressure tubing and fittings. Modern systems consist of one or more computer-controlled metering pumps that can be programmed to vary the ratio of mobile phase components, as is required for gradient elution chromatography, or to make an isocratic mobile phase (i.e., mobile phases having a fixed ratio of solvents). The system should be capable of delivering the mobile phase at a constant rate with minimal fluctuations over extended periods of time. Pumps may be provided with a mechanism for 'bleeding' the system of any entrapped air.

**Injectors**

After dissolution in the mobile phase or other suitable solvent, samples that are to be chromatographed are injected, either manually by a syringe or by fixed-loop injectors, or automatically by autosamplers. An autosampler consists of a



carousel or rack to hold sample vials with tops that have a pierceable septum or stopper and an injection device to transfer samples from the vials to a loop from which it is loaded into the chromatograph. Some autosamplers can be programmed to control sample volume, the number of injections and loop rinse cycles, the interval between injections, and other operating variables like temperature. Manual partial filling of loops is not recommended because of poorer injection volume precision.

### Stationary phases and columns

The different types of stationary phases employed in liquid chromatography are:

- silica, alumina or porous graphite, used in normal-phase chromatography, wherein separation is based on the principle of adsorption and/or mass distribution,
- chemically modified silica, polymers or porous graphite, used in reversed-phase chromatography, wherein separation is based principally on partition of the molecules between the mobile phase and the stationary phase,
- resins or polymers with acid or basic groups, used in ion exchange chromatography, wherein separation is based on competition of the ions to be separated with those in the mobile phase,
- porous silica or polymers, used in size-exclusion chromatography, wherein separation is based on differences between the volumes of the molecules to be separated and the corresponding steric exclusion,
- stationary phases like cellulose or amylose derivatives, proteins or peptides, cyclodextrins, etc., chemically modified specially for chiral chromatography for separation of enantiomers.

For most pharmaceutical analysis, separation is achieved by partitioning of compounds in the test solution between the mobile and stationary phases. Systems consisting of polar stationary phases and non-polar mobile phases are described as normal phases while the opposite arrangement (i.e., polar mobile phases and non-polar stationary phases) are called reversed-phases. In reversed-phase chromatography utilising chemically modified silica, the silanol groups of silica on the surface of the support react with various silane reagents to produce covalently bound silyl derivatives covering a varying number of active sites on the surface of the support. The nature of the bonded phase influences the separation properties of the chromatographic system. Commonly used bonded phases are octyl (C<sub>8</sub>), octadecyl (C<sub>18</sub>), phenyl (C<sub>6</sub>H<sub>5</sub>), cyanopropyl (CN), aminopropyl (NH<sub>2</sub>) and diol.

Unless otherwise stated by the manufacturer, silica-based reversed-phase columns are considered to be stable in a mobile phase having an apparent pH in the range 2.0 to 8.0. It is

advisable to use a pre-column before the analytical column while using mobile phases of high pH with a silica-based column. Columns composed of porous graphite or particles of polymeric materials like styrene-divinylbenzene copolymer are stable over a wider range of pH. Making the mobile phase more or less polar controls the affinity of a compound for the stationary phase, and thus its retention time on the column. Mobile phase polarity can be varied by the addition of a second, and sometimes a third or even a fourth, component.

For analytical separations, the particle size of the most commonly used stationary phases varies between 3 µm and 10 µm. The particles may be spherical or irregular, of varying porosity and specific surface area. These parameters contribute to the chromatographic behaviour of a particular stationary phase. In the case of reversed phases, the nature of the stationary phase, the extent of bonding, e.g., expressed as the carbon loading, and whether the stationary phase is end capped (i.e. residual silanol groups are silylated) or base deactivated are additional determining factors. When residual silanol groups are present, tailing of peaks particularly of basic substances can occur.

*Base deactivation of the stationary phases is carried out by removal of basic components by careful washing and hydrolysing most of the superficial siloxane bridges.*

Columns are usually made of stainless steel unless otherwise specified in the monograph. For analytical chromatography, they may be of varying length and internal diameter. Columns with internal diameters of less than 2 mm are often referred to as microbore columns.

In ion exchange chromatography, the column is made of a rigid material, usually plastic. It is generally 5 cm to 30 cm long with an internal diameter of 2 mm to 10 mm. The stationary phase is usually in the form of small diameter particles, 5 µm to 10 µm, uniformly packed into the column. The cation exchangers are usually obtained by sulphonation and anion exchangers by attaching quaternary ammonium groups to the polymeric resins.

The temperature of the mobile phase and the column must be kept constant during an analysis. Most separations are performed at ambient conditions, but columns may be heated to give higher efficiency. In order to reduce the possibility of degradation of the stationary phase or of occurrence of changes in the composition of the mobile phase, heating of the columns above 60° is not recommended. In some cases a particular commercial brand of column that has been found suitable is mentioned, but such statements do not imply that a different but equivalent commercial brand cannot be used. It may be necessary with a particular chromatograph to modify the conditions specified in the monograph but it should be ensured that comparable results are obtained under the modified conditions.

### Detectors

A detector consists of a flow through cell mounted at the end of the column and capable of detecting various types of components in the eluate. The recommended volume of the detector flow cell is 3  $\mu\text{l}$  to 20  $\mu\text{l}$ . Ultraviolet/visible (UV/Vis) spectrophotometers, including diode array detectors, are the most commonly employed detectors. A beam of UV radiation passes through the flow cell and into the detector. As compounds elute from the column, they pass through the cell and absorb the radiation, resulting in measurable energy level changes. The wavelength setting is specified in the individual monograph.

Fluorescence spectrophotometers, differential refractometers, electrochemical detectors, mass spectrometers, light scattering detectors, radioactivity detectors or other special detectors may also be used. Fluorimetric detectors are sensitive to compounds that are fluorescent or that can be converted to fluorescent derivatives. Differential refractometer detectors measure the difference between the refractive index of the mobile phase alone and that of the mobile phase containing chromatographed compound as it emerges from the column. Electrochemical detectors are suitable for measuring nanogram quantities of easily oxidisable compounds like phenols and catechols.

Conductivity detector is the detector of choice in ion exchange chromatography. UV-visible detectors for absorbing species, indirect UV-visible detectors, amperometric detectors and fluorescence detectors are also employed for specific applications.

### Mobile phases

In case of normal-phase chromatography, less polar solvents (e.g. hexane, dichloromethane) are employed. The presence of water or polar solvents in the mobile phase is to be strictly controlled to obtain reproducible results. In reversed-phase chromatography, aqueous mobile phases or polar solvents with or without organic modifiers are employed. Components of the mobile phase are usually filtered to remove particles greater than 0.45  $\mu\text{m}$ . Multicomponent mobile phases are prepared by measuring the required volumes (unless masses are specified) of the individual components, followed by mixing. Alternatively, individual pumps controlled by proportioning valves, which mix the solvents in the desired proportion, may deliver the solvents. It is advisable to have the mobile phase solvents or solvent mixtures degassed using a vacuum pump or other suitable means that will not affect the composition of the mixture. For accurate quantitative analysis, high purity reagents and HPLC grade organic solvents must be used. Adjustment of the pH, if necessary, is effected using the aqueous component of the mobile phase. The system is flushed with a mixture of water and the organic modifier of the mobile phase (in a suitable composition) after the completion

of chromatography when buffer solutions are used. On completion of the analysis, it is necessary to wash the column with appropriate solvent followed by storage in recommended solvent. During storage, both the ends of column need to be plugged properly to prevent drying of the column bed.

A counter-ion for ion-pair chromatography or a chiral selector for chromatography using an achiral stationary phase may also be used to modify mobile phases.

### Data acquisition systems

Modern data stations receive and store detector output and print out chromatograms complete with peak heights, peak areas as well as sample identification and method variables. Data may be collected on simple recorders for manual measurement or on stand alone integrators, which range in complexity from those providing a printout of peak areas to those providing chromatograms with peak areas and peak heights calculated and data stored for possible subsequent reprocessing.

### Method

Equilibrate the column with the prescribed mobile phase and flow rate, at room temperature or at a temperature specified in the monograph, until a stable baseline is achieved. Prepare the test and standard solutions as described in the individual monograph. The solutions should be free from solid particles. A blank injection of the mobile phase and the sample diluent should be carried out and monitored during the test to detect any interference.

### Performance

Reliable quantitative results are obtained by direct comparison of the peak responses obtained by separately chromatographing the test and standard solutions. In order to achieve reproducible results, a fixed-volume loop injector is recommended particularly where the use of an internal standard is not specified in the monograph. In exceptional cases, the use of peak heights alone is prescribed in the monograph; if so, peak heights should be used irrespective of the symmetry factor. In some monographs, a known amount of a non-interfering compound, the internal standard, is added to the test and standard solutions, and the ratios of the peak responses of drug and internal standard are compared. This is particularly important if the sample is injected manually with a syringe where reproducibility is difficult because of working under high pressures.

Peak areas and peak heights are usually proportional to the quantity of compounds eluting. Peak areas are generally used but may be less accurate if peak interference occurs. For accurate quantitative work, the components to be measured should be separated from any interfering components. Peak tailing and fronting and the measurement of peaks on solvent

tails are to be avoided. Related compound or purity test for drug raw materials are sometimes based on the determination of peaks due to impurities, expressed as a percentage of the area due to the drug peak. It is preferable, however, to compare impurity peaks to the chromatogram of a standard at a similar concentration. The standard may be the drug itself at a level corresponding to, for example, 0.5 per cent impurity, or in the case of toxic or signal impurities, a standard of the impurity itself.

### Secondary peak

This is a peak in the chromatogram other than the principal peak and any peak due to internal standard.

### Normalisation

Where reference is made to normalisation for the assessment of one or more components or related substances, the total area of the peak or peaks due to the components or related substances is expressed as a percentage of the sum of the areas of all the peaks derived from the substance under examination.

### System suitability

This is an integral part of liquid chromatographic method for assuring adequate performance of the system. Because of normal variations in equipment, supplies and techniques, a system suitability test is required to ensure that a given operating system may be generally applicable. System

suitability also verifies that the resolution and reproducibility of the chromatographic system are adequate for the analysis to be done.

### Adjustment of chromatographic conditions

Some adjustments of chromatographic conditions may be done for obtaining the required system suitability requirements. These include:

*Mobile phase.* Minor solvent component of a mixture:  $\pm 30$  per cent relative or  $\pm 2$  per cent absolute, whichever is the larger; no other component altered by more than 10 per cent absolute;

*Concentration of salts.* In the buffer component of the mobile phase;  $\pm 10$  per cent;

*pH of the aqueous component of the mobile phase.*  $\pm 0.2$  pH, unless otherwise stated in the monograph, or  $\pm$  pH when neutral substances are to be examined;

*Detector wavelength.* No adjustment;

*Stationary phase.*

- column length:  $\pm 70$  per cent,
- column internal diameter:  $\pm 25$  per cent,
- particle size: reduction of not more than 50 per cent, no increase;

*Flow rate.*  $\pm 50$  per cent. If in the monograph, the retention time of the principal peak is indicated, the flow rate may be adjusted if the column internal diameter has been changed.

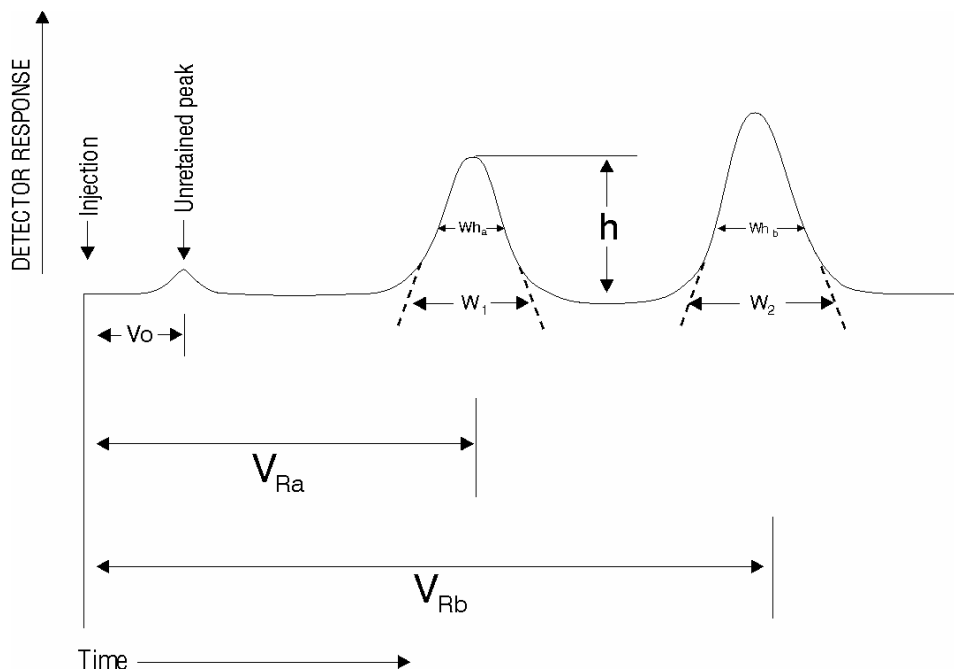

Fig. 2.4.14-1

No decrease in the flow rate if the monograph uses apparent number of theoretical plates in the qualification statement;

*Temperature.*  $\pm 10$  per cent, to a maximum of  $60^\circ$ ;

*Injection volume.* May be increased if detection and repeatability of the peak(s) to be determined are satisfactory.

Multiple adjustments should be avoided as they may have a cumulative effect on the performance of the system.

Sometimes, particularly in reversed-phase chromatographic methods, it may be advisable to change the column with another of the same type (e.g.  $C_{18}$  silica gel) from another manufacturer.

Fig. 2.4.14.1 is a graphical representation of the common events during chromatography and assists in understanding the various terms more commonly employed and discussed below.

### Resolution

The resolution or resolution factor,  $R$ , is specified to ensure that closely eluting compounds are resolved from each other, to establish the general resolving power of the system, and to ensure that internal standards are resolved from the drug. Resolution between peaks of similar height of two components may be defined by the expression:

$$R = \frac{2 (V_{Rb} - V_{Ra})}{W_2 + W_1}$$

Where,  $V_{Rb}$  and  $V_{Ra}$  = retention times or distances along the baseline between the point of injection and perpendiculars dropped from the maxima of two adjacent peaks.

$W_2$  and  $W_1$  = corresponding widths at the bases of the peaks obtained by extrapolating the relatively straight sides of the peaks to the base line.

Where electronic integrators are used, it may be convenient to determine the resolution,  $R$ , by the equation

$$R = \frac{1.18 (V_{Rb} - V_{Ra})}{W_{ha} + W_{hb}}$$

Where,  $V_{Rb}$  and  $V_{Ra}$  = retention times or distances along the baseline between the point of injection and perpendiculars dropped from the maxima of two adjacent peaks,

$W_{hb}$  and  $W_{ha}$  = the respective peak widths measured at half-peak height.

The values of  $W_{ha}$ ,  $W_{hb}$ ,  $V_{Ra}$  and  $V_{Rb}$  must be expressed in the same unit of measurement.

### Capacity factor

The capacity factor, also called mass distribution ratio,  $K'$ , is stated in the monograph. It is defined by the expression

$$K' = (V_{Rb} - V_o) / V_o$$

Where,  $V_{Rb}$  = retention time or distance along the baseline between the point of injection and perpendicular dropped from the maximum of the peak of interest.

$V_o$  = the distance along the baseline between the point of injection and perpendicular dropped from the maximum of the peak of an unretained component.

The values of  $V_{Rb}$  and  $V_o$  must be expressed in the same unit of measurement.

### Column efficiency

Column efficiency can also be used as a system suitability requirement. It is a measure of peak sharpness, which is important for the detection of trace components. It is defined in terms of the number of theoretical plates,  $N$ , by the expression

$$N = 5.54 V_R^2 / W_h^2$$

Where,  $V_R$  = retention time or distance along the baseline between the point of injection and a perpendicular dropped from the maximum of the peak of interest,

$W_h$  = the width of the peak of interest at half-peak height.

The values of  $V_R$  and  $W_h$  must be expressed in the same unit of measurement.

### Symmetry factor

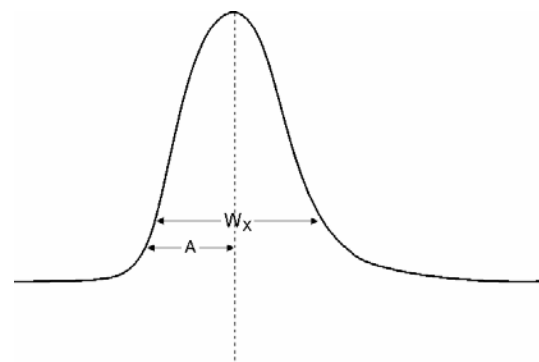

Fig. 2.4.14-2

Symmetry factor or tailing factor,  $S$ , of a peak (Fig. 2.4.14-2) is a measure of peak symmetry. It is unity for perfectly symmetrical peaks and its value increases as tailing becomes more pronounced. It is calculated from the expression

$$S = W_x / 2A$$

Where,  $W_x$  = the width of the peak at 5.0 per cent of the peak height,

$A$  = the distance between the perpendicular dropped from the peak maximum and the leading edge of the peak at 5.0 per cent of the peak height.

#### Relative retention

Relative retention,  $r_{a/b}$ , is calculated as an estimate from the expression

$$r_{a/b} = \frac{t_{r,b}}{t_{r,a}}$$

Where,  $t_{r,b}$  = retention time of the peak of interest,

$t_{r,a}$  = retention time of the reference peak (usually the peak corresponding to the substance under examination).

#### Signal to noise ratio

The signal-to-noise ratio is determined from the expression:

$$S/N = 2H / h$$

Where,  $H$  = height of the peak corresponding to the component concerned, in the chromatogram obtained with the prescribed reference solution, measured from the maximum of the peak to the extrapolated baseline of the signal observed over a distance equal to 20 times the width at half-height.

$h$  = range of the background noise in a chromatogram obtained after injection of a blank, observed over a distance equal to 20 times the width at half-height of the peak in the chromatogram obtained with the prescribed reference solution and, if possible, situated equally around the place where this peak would be found.

#### Relative standard deviation

Replicate injections of a standard preparation used in the assay or other standard solution are done to ascertain whether requirements for precision are met. Unless otherwise specified in the individual monograph data from five replicate injections of the standard are used to calculate the relative standard

deviation, if the requirement is 2.0 per cent or less. Data from six replicate injections are used if the relative standard deviation requirement is more than 2.0 per cent.

### 2.4.15 Paper Chromatography

Paper chromatography is a technique in which separation of the components of a mixture is achieved through the action of a single liquid phase in a process similar to adsorption chromatography in columns and in which a sheet of paper of suitable texture and thickness acts as the adsorbant. Since the natural water content of the paper, or selective inhibition of a hydrophilic component of the liquid phase by the paper may be regarded as a stationary phase, a partitioning of the solute between two phases may contribute to the separation of components.

Alternatively, a two-phase system may be adopted in which the paper is impregnated with one of the phases, which then remains stationary and the chromatogram is developed by slow movement of the other, mobile, phase over the sheet. Development may be ascending in which case the mobile phase is carried up the paper by capillary forces, or descending in which case the mobile phase is also assisted by gravitational force.

#### Apparatus

- A vapour-tight tank of glass, porcelain or stainless steel provided with inlets for addition of solvent or for releasing internal pressure and so designed that the progress of the chromatographic run can be observed without opening the tank.
- A rack of corrosion-resistant material about 5 cm shorter than the inside height of the tank, to serve as support for the solvent trough and for antisiphoning rods which in turn, hold the chromatographic sheets.
- Glass troughs, longer than the width of the chromatograph sheets and holding a volume of solvent greater than that needed for one chromatographic run.
- Antisiphoning rods of heavy glass to be supported by the rack, and running outside of, parallel to and slightly above the edge of the glass trough.
- Chromatographic sheets of special filter paper not less than 25 mm wide and not wider than the length of the troughs, cut into strips to a length approximately equal to the height of the tank; the paper is cut so that the mobile phase runs in the direction of the grain of the paper. A fine pencil line is drawn horizontally across the filter paper at a distance from one end such that, when the sheet is suspended from the antisiphoning rods with the upper end of the paper resting in the trough and the lower portion hanging free into the chamber, the line is located a few cm



below the rods. Care should be taken to avoid contaminating the filter paper by excessive handling or by contact with dusty surfaces.

### Descending Paper Chromatography

**Method.** The substance under examination is dissolved in a suitable solvent. The volumes of the resulting solution are applied by means of micropipette in 6 to 10 mm spots along the pencil line not less than 3 cm apart. If the total volume to be applied would produce spots of a diameter greater than 6 to 10 mm, it is applied in separate portions to the same spot, each portion being allowed to dry before the next is added, or alternatively, the solution may be applied in the form of bands (10 to 20 mm x 2 to 6 mm unless otherwise specified) along the pencil line.

Use sufficient of the saturating solvent prescribed in the monograph to form a 25 mm layer in the bottom of the tank. Close the tank and allow to stand for 24 hours at room temperature.

Suspend the spotted chromatographic sheet in the tank by the use of antisiphoning rods which hold the upper end of the sheet in the solvent trough. It is important to ensure that the portion of the sheet hanging below the rods is freely suspended in the tank without touching the rack or the tank walls or the fluid in the tank.

Close the tank and allow the paper to stand in it for 1.5 hours. Introduce through the inlet into the solvent trough a sufficient quantity of the prescribed mobile phase, close the tank and allow development to proceed for the distance or the time prescribed in the monograph, protecting the paper from bright light during development. Remove the paper from the tank and allow it to dry in air at the temperature specified in the monograph. Visualise the spots as described in the monograph. The paper section(s) (see under Apparatus) predetermined to contain the separated components may be cut out and eluted by an appropriate solvent, and the solutions may be made up to a known volume and quantitatively analysed by appropriate chemical or instrumental methods.

### Ascending Paper Chromatography

**Method.** The test materials are applied to the chromatographic sheets as directed under Descending Paper Chromatography and above the level to which the paper is dipped into the developing solvent. The top of the tank contains a device from which the paper is suspended, and which is capable of being lowered without opening the tank. In the bottom of the tank is a trough to contain the mobile phase into which the paper may be lowered.

Use sufficient of the prescribed mobile phase to form a 25 mm layer in the trough. If a two-phase system is used, both phases are added. If prescribed, pour the saturating solvent between the trough and the walls of the tank. Close the tank and allow

to stand for 24 hours at room temperature. Insert the prepared paper into the tank, close the lid and allow to stand for 1½ hours. Lower the paper into the mobile phase and allow development to proceed for the distance or the time prescribed in the monograph, protecting the paper from bright light during development. Remove the paper from the tank and allow it to dry in air at the temperature specified in the monograph. Qualitative and quantitative analyses of the spots may be conducted as described under Descending Paper Chromatography.

## 2.4.16 Size-Exclusion Chromatography

Size-exclusion chromatography is a technique of separation of molecules in solution according to their size. It is based on the repeated exchange of solute molecules between the solvent of the mobile phase and the same solvent in the stagnant liquid phase (stationary phase) within the pores of the column-packing material. The pore-size range of the packing material determines the molecular-size range within which separation can take place.

Molecules small enough to penetrate all the pore spaces elute at the total permeation volume ( $V_t$ ). Molecules apparently larger than the maximum pore size of the packing material migrate along the column only through the spaces between the particles of the packing material without being retained and elute at the exclusion volume ( $V_o$  void volume). Separation according to molecular size takes place between the exclusion volume and the total permeation volume with useful separation occurring in the first two thirds of this range.

### Apparatus

A chromatographic column, temperature-controlled, if necessary, packed with a separation material capable of fractionation in the appropriate range of molecular sizes and through which the eluent is passed at a constant rate. The dimensions of the column are stated in the individual monograph as (length x internal diameter). The mobile phase is passed through the column either by gravity or by means of a pump. The outlet from the column is connected to a detector fitted with an automatic recorder that allows the monitoring of the relative concentrations of the components of the sample. Detectors are usually based on photometric, refractometric or luminescent properties. An automatic fraction-collector may be attached, if required.

The packing material may be a soft support such as a swollen gel or a rigid support such as glass, silica or a solvent-compatible, cross-linked organic polymer. Rigid supports usually require pressurised systems giving faster separations. Before carrying out the separation, the packing material is treated, and the column is packed as described in the monograph, or according to the manufacturer's instructions.

The temperature of the column, if other than that of the room, the nature of the packing material, the composition and flow rate of the mobile phase and the means of detection are stated in the individual monograph.

### Performance

The column efficiency may be derived as described under Gas chromatography (2.4.13) but the term in the expression for calculation is called the retention volume ( $V_R$ ) for the component of interest. The retention volume is the distance along the baseline between the point of injection and a perpendicular dropped from the maximum of the peak of interest.

The distribution coefficient ( $K_D$ ), where stated in the monograph, is calculated from the expression

$$K_D = (V_R - V_O) / (V_T - V_O)$$

The values of  $V_R$ ,  $V_O$ , and  $V_T$  must be expressed in the same unit of measurement.

### Determination of relative component composition

If all of the components of the sample under examination exhibit equivalent responses to the detector, then the relative amount of each component can be determined by dividing each peak area by the sum of the peak areas of the components of interest. If the responses are not equivalent, calculate the relative component composition either from the calibration curves obtained with the calibration standards specified in the monograph or by any other means.

### Determination of molecular weight

Carry out the method on the substance under examination and calibration standards using the procedure given in the individual monograph. Plot a graph of the retention volume of the standards as a function of the logarithm of the molecular weight. The curve is almost a straight line within the exclusion and total permeation limits. The molecular weight of the component of interest may be estimated from the calibration curve. The calibration is valid only for the particular system used under the specified experimental conditions.

### Materials

**Agarose FC.** For the separation of proteins with molecular weights of  $6 \times 10^4$  to  $2 \times 10^7$  and of polysaccharides with molecular weights of  $3 \times 10^3$  to  $5 \times 10^6$ . They occur as swollen beads 60 to 140  $\mu\text{m}$  in diameter and are available as a 4 per cent suspension in *water*.

**Agarose FC, Cross-linked.** It is prepared from agarose by reaction with 2,3-dibromo-1-propanol in strongly alkaline conditions. It is used for separation of proteins with molecular weights of  $6 \times 10^4$  to  $2 \times 10^6$  and of polysaccharides of the same range of molecular weights as with Agarose FC.

**Silica Gel FC.** For the separation of proteins with molecular weights of  $1 \times 10^3$  to  $3 \times 10^5$ . It occurs as a very finely divided powder with an average particle size of about 10  $\mu\text{m}$  with a very hydrophilic surface and an average pore diameter of about 30 nm. It is compatible with aqueous solutions of pH 2 to 8 and with organic solvents.

## 2.4.17. Thin-Layer Chromatography

Thin-layer chromatography is a technique in which a solute undergoes distribution between two phases, a stationary phase acting through adsorption and a mobile phase in the form of a liquid. The adsorbent is a relatively thin, uniform layer of dry finely powdered material applied to a glass, plastic or metal sheet or plate. Glass plates are most commonly used. Separation may also be achieved on the basis of partition or a combination of partition and adsorption, depending on the particular type of support, its preparation and its use with different solvent.

Identification can be effected by observation of spots of identical  $R_f$  value and about equal magnitude obtained, respectively, with an unknown and a reference sample chromatographed on the same plate. A visual comparison of the size and intensity of the spots usually serves for semi-quantitative estimation.

### Apparatus

- Flat glass plates of appropriate dimensions which allow the application at specified points of the necessary quantities of the solution being examined and appropriate reference solutions and which allow accommodation of the specified migration path-length. The plates are prepared as described below; alternatively, commercially available pre-coated plates may be used.
- An aligning tray or a flat surface on which the plates can be aligned and rested when the coating substance is applied.
- The adsorbent or coating substance consisting of finely divided adsorbent materials, normally 5  $\mu\text{m}$  to 40  $\mu\text{m}$  in diameter, suitable for chromatography. It can be applied directly to the plate or can be bonded to the plate by means of Plaster of Paris (Hydrated Calcium Sulphate) or with any other suitable binders. The adsorbent may contain fluorescing material to help in visualising spots that absorb ultraviolet light.
- A spreader which, when moved over the glass plate, will apply a uniform layer of adsorbent of desired thickness over the entire surface of the plate.
- A storage rack to support the plates during drying and transportation.

- (f) A developing chamber that can accommodate one or more plates and can be properly closed and sealed. The chamber is fitted with a plate support rack that supports the plates, back to back, with the lid of the chamber in place.
- (g) Graduated micro-pipettes capable of delivering microlitre quantities say 10 ml and less.
- (h) A reagent sprayer that will emit a fine spray and will not itself be attacked by the reagent.
- (i) An ultraviolet light, suitable for observation at short (254 nm) and long (365 nm) ultraviolet wavelengths.

**Preparation of plates.** Unless otherwise specified in the monograph, the plates are prepared in the following manner. Prepare a suspension of the coating substance in accordance with the instructions of the supplier and, using the spreading device designed for the purpose, spread a uniform layer of the suspension, 0.25 to 0.30 mm thick, on a flat glass plate 20 cm long. Allow the coated plates to dry in air, heat at 100° to 105° for at least 1 hour (except in the case of plates prepared with cellulose when heating for 10 minutes is normally sufficient) and allow to cool, protected from moisture. Store the plates protected from moisture and use within 3 days of preparation. At the time of use, dry the plates again, if necessary, as prescribed in the monograph.

#### Method

Unless unsaturated conditions are prescribed, prepare the tank by lining the walls with sheets of filter paper; pour into the tank, saturating the filter paper in the process, sufficient of the mobile phase to form a layer of solvent 5 to 10 mm deep, close the tank and allow to stand for 1 hour at room temperature. Remove a narrow strip of the coating substance, about 5 mm wide, from the vertical sides of the plate. Apply the solutions being examined in the form of circular spots about 2 to 6 mm in diameter, or in the form of bands (10 to 20 mm x 2 to 6 mm unless otherwise specified) on a line parallel with, and 20 mm from, one end of the plate, and not nearer than 20 mm to the sides; the spots should be 15 mm apart. If necessary, the solutions may be applied in portions, drying between applications. Mark the sides of the plate 15 cm, or the distance specified in the monograph, from the starting line. Allow the solvent to evaporate and place the plate in the tank, ensuring that it is as nearly vertical as possible and that the spots or bands are above the level of the mobile phase. Close the tank and allow to stand at room temperature, until the mobile phase has ascended to the marked line. Remove the plate and dry it.

For two-dimensional chromatography dry the plate after the first development and carry out the second development in a direction perpendicular to the first.

When the method prescribed in the monograph specifies 'protected from light' or 'in subdued light' it is intended that the entire procedure is carried out under these conditions.

#### Adjustment of chromatographic conditions

Minor adjustments to the parameters of the test may be made in order to satisfy the system suitability criteria. These may be:

*Mobile phase.* Minor solvent component of a mixture:  $\pm 30$  per cent relative or  $\pm 2$  per cent absolute, whichever is the larger; no other component altered by more than 10 per cent absolute;

*Concentration of salts.* In the buffer component of the mobile phase;  $\pm 10$  per cent;

*pH of the aqueous component of the mobile phase.*  $\pm 0.2$  pH, unless otherwise stated in the monograph, or  $\pm$  pH when neutral substances are to be examined;

*Volume of solutions applied:* 10-20 per cent of the prescribed volume if plates have fine particles (2-10  $\mu\text{m}$ ).

#### Visualisation

After development, the plate should be examined under an ultraviolet light having a maximum output at about 254 nm or at about 365 nm, as the case may be. Alternatively, it may be visualised as directed in the monograph; where a spraying technique is prescribed it is essential that the reagent be evenly applied as a fine spray.

The term secondary spot means any spot other than the principal spot. Similarly, a secondary band is any band other than the principal band.

#### Semi-quantitative estimation

**Identification.** The principal spot in the chromatogram obtained with the test solution is visually compared to the corresponding spot in the chromatogram obtained with the reference solution in respect of the colour, the size and the  $R_f$  of the spots.

**Test for Related substances.** The secondary spot(s) in the chromatogram obtained with the test solution is (are) visually compared to either the corresponding spot(s) in the chromatogram obtained with the reference solution containing the impurity (ies) or the spot in the chromatogram obtained with the reference solution prepared from a dilution of the test solution.

#### Quantitative measurement

The substances that have been separated after development of the plate and that respond to UV-Vis irradiation can be estimated directly on the plate with suitable instrumentation. Measurement is of the reflectance of the incident light from the spots by moving the plate or the measuring device. Likewise, fluorescence may be measured using an appropriate optical system.

**Apparatus.** The apparatus for direct measurement consist of:

- a device for exact positioning and reproducible application of the amount of solutions onto the plate,
- a mechanical device for moving the plate or the measuring device along the *x*-axis or the *y*-axis,
- a recorder and a suitable integrator or a computer, and
- a photometer with a source of light, an optical device for generating monochromatic light and a photo cell of adequate sensitivity; for measurement of fluorescence, a suitable filter to prevent light used for excitation from reaching the detector while permitting emitted light or a specific portion thereof to pass.

**Method.** Prepare the test solution and reference solutions as prescribed in the individual monograph. Use the same solvent for all the solutions and apply the same volume of each and develop the plate. Prepare and apply not fewer than 3 reference solutions of the substance under examination, the concentrations of which span the expected value in the test solution (about 80 per cent, 100 per cent and 120 per cent). Treat with the prescribed reagent, if necessary, and record the reflectance, the transmittance or fluorescence in the chromatograms obtained with all the solutions. Use the measured results to calculate the amount of substance in the test solution.

The requirement for resolution and separation are prescribed in the individual monograph.

### 2.4.18. Jelly Strength

The jelly strength of Gelatin is the weight, in g, necessary to give a 4-mm depression in a jelly containing 6.67 per cent w/w, matured at 10°, using a plunger 12.7 mm in diameter.

#### Apparatus

A gelometer consisting of a cylindrical piston 12.6 to 12.8 mm in diameter with a plane pressure surface with a rounded edge 0.5 mm in radius attached to a device whereby the load exerted by the piston can be increased at a constant rate of 40 g per second and the vertical movement of the piston can be stopped within 0.025 seconds when it has descended 3.9 to 4.1 mm.

#### Method

Place 7.5 g of the substance under examination in a bottle, 58 to 60 mm in internal diameter and 85mm high, add 105 ml of water, cover the bottle with a watch glass and allow to stand for 3 hours. Heat in a water-bath at 65° for 15 minutes, stirring gently with a glass rod ensuring that the solution is uniform and that any condensed water on the inner walls of the bottle is incorporated. Allow to cool at room temperature for 15 minutes, transfer to a water-bath maintained at 9.9° to 10.1°

and ensure that the base of the bottle is horizontal. Close the bottle with a rubber stopper and allow to stand for 16 to 18 hours. Immediately transfer the bottle to the gelometer and adjust the height of the bottle so that the piston just comes into contact with the surface of the gel without exerting any pressure. Increase the load on the piston at a rate of 40 g per second until it has descended 3.9 to 4.1 mm. The load, measured within a precision of  $\pm 0.5$  g, exerted by the piston at that moment represents the jelly strength. Carry out five determinations and use the mean value.

### 2.4.19. Loss on Drying

Loss on drying is the loss of weight expressed as percentage w/w resulting from water and volatile matter of any kind that can be driven off under specified conditions. The test is carried out on a well-mixed sample of the substance. If the substance is in the form of large crystals, reduce the size by rapid crushing to a powder.

Unless otherwise specified in the individual monograph, use Method A.

#### Method A

Weigh a glass-stoppered, shallow weighing bottle that has been dried under the same conditions to be employed in the determination. Transfer to the bottle the quantity of the sample specified in the individual monograph, cover it and accurately weigh the bottle and the contents. Distribute the sample as evenly as practicable by gentle sidewise shaking to a depth not exceeding 10mm.

Dry the substance by placing the loaded bottle in the drying chamber as directed in the monograph, remove the stopper and leave it also in the chamber. Dry the sample to constant weight or for the specified time and at the temperature indicated in the monograph. Dry by one of the following procedures. After drying is completed, open the drying chamber, close the bottle promptly and allow it to cool to room temperature (where applicable) in a desiccator before weighing. Weigh the bottle and the contents.

- a) “in a desiccator”: dry over *phosphorus pentoxide* at atmospheric pressure and at room temperature;  
*NOTE* — Care must be taken to keep the desiccant fully effective by frequent replacement.
- b) “in vacuo”: dry over *phosphorus pentoxide*, at a pressure of 1.5 kPa to 2.5 kPa at room temperature;
- c) “in vacuo within a specified temperature range”: dry over *phosphorus pentoxide*, at a pressure of 1.5 kPa to 2.5 kPa within the temperature range given in the monograph;
- d) “in an oven within a specified temperature range”: dry in an oven within the range given in the monograph;



*NOTE* — Where the drying temperature is indicated by a single value, dry at the prescribed temperature  $\pm 2^\circ$ .

- e) “under high vacuum”: dry over *phosphorus pentoxide*, at a pressure not exceeding 0.1kPa, at the temperature given in the monograph.

#### Method B

**Thermogravimetry.** Thermogravimetry is a technique in which the weight of a sample is recorded as a function of temperature according to a controlled temperature programme.

#### Apparatus

A thermobalance consisting of a device for heating or cooling the substance being examined according to a given temperature programme, a sample holder in a controlled atmosphere, an electrobalance and a recorder. The instrument may be coupled to a device permitting the analysis of volatile products.

**Temperature verification.** Check the temperature scale using nickel or other suitable material according to the manufacturer’s instruction.

#### Calibration of the electrobalance

Place a suitable quantity of *calcium oxalate monohydrate RS* in the sample holder and record the weight. Set the heating rate according to the manufacturer’s instructions and start the temperature programme. Record the thermogravimetric curve as a graph with temperature on the abscissa, increasing from left to right, and weight on the ordinate, increasing upwards. Stop the rise in temperature at  $230^\circ$ . Measure the distance on the graph between the initial and final weight-temperature plateaux that corresponds to the loss of weight. The declared loss of weight for *calcium oxalate monohydrate RS* is stated on the label.

*Note* — If the apparatus is in frequent use, carry out temperature verification and calibration regularly. Otherwise, carry out such checks before each measurement.

#### Procedure

Apply the same procedure to the substance under examination, using the conditions prescribed in the monograph. Calculate the loss of weight of the substance under examination from the distance measured on the graph obtained and express as a percentage w/w of the substance taken.

The actual procedure and the calculations to be employed are dependent on the particular instrument used. Consult the manufacture’s literature and/or the thermal analysis literature for the most appropriate technique for a given instrument. In any event, it is imperative to keep in mind the limitations of solid solution formation, insolubility in the melt, polymorphism and decomposition during the analysis.

### 2.4.20. Loss on Ignition

Loss on ignition is the loss in weight in per cent w/w resulting from a part of any test material, that is volatilised and driven off under specified conditions. The test is performed on finely powdered material; lumps, if any should be broken up with the aid of a mortar and pestle.

#### Method

Weigh a silica or platinum crucible, complete with the lid, previously ignited for 1 hour at the temperature specified for the test and cooled in a desiccator. Transfer to the crucible the quantity of the substance specified in the individual monograph, without any treatment, unless a preliminary drying at a lower temperature, or other special treatment is specified. Weigh accurately the crucible, lid and the contents. Place the loaded uncovered crucible and cover in a suitable muffle furnace or oven that is capable of maintaining a temperature within  $25^\circ$  of that required for the test. Ignite the crucible for the period of time and at the temperature stated in the monograph. Ignite for successive 1-hour periods where ignition to constant weight is indicated. Upon the completion of each ignition, cover the crucible and allow it to cool in a desiccator to room temperature before weighing.

### 2.4.21. Melting Range or Temperature

In this Pharmacopoeia, melting range or temperature of a substance is defined as those points of temperature within which, or the point at which, the substance begins to coalesce and is completely melted except as defined otherwise for certain substances. The following procedures are suitable for the various substances described in the Pharmacopoeia. Any other apparatus or method capable of the same accuracy may also be used. The accuracy should be checked frequently by using certified reference substances of declared melting point, such as those of the World Health Organization or other suitable substances, the reference substance selected being one that melts nearest to the melting range of the substance to be examined.

Unless otherwise specified in the individual monograph, use Method I.

#### Method I

#### Apparatus

- (a) A glass heating vessel of suitable construction and capacity containing one of the following or any other suitable bath liquid, to a height of not less than 14 cm.
  - (i) Water for temperatures upto  $60^\circ$ .
  - (ii) Glycerin for temperatures upto  $150^\circ$ .
  - (iii) Liquid paraffin of sufficiently high boiling range for temperatures upto  $250^\circ$ .



- (iv) Sesame oil or a suitable grade of silicone oil for temperatures upto 300°.
- (b) A suitable stirring device capable of rapidly mixing the liquids.
- (c) An accurately standardised thermometer suitable for the substance under examination (see Appendix 2.1.4). The thermometer must be positioned in the bath liquid to its specified immersion depth and yet leave the bulb about 2 cm above the bottom of the bath.
- (d) Thin-walled capillary glass tubes of hard glass, closed at one end, about 12 cm long, with a thickness of 0.2 to 0.3 mm and an internal diameter of 0.8 to 1.1 mm. The tubes should preferably be kept sealed at both ends and cut as required. A suitable magnifying glass may be used for observation of melting in the capillary tube.
- (e) A source of heat (open flame or electric heater).

### Procedure

Reduce the substance to a very fine powder and, unless otherwise directed, dry it at a temperature considerably below its melting temperature or at a pressure of 1.5 to 2.5 kPa over *self-indicating silica gel* for 24 hours. Introduce into a capillary glass tube, a sufficient quantity of the dry powder to form a compact column 4 to 6 mm high. Heat the bath until the temperature is about 10° below the expected melting temperature. Remove the thermometer and quickly attach the capillary tube to the thermometer by wetting both with a drop of the liquid of the bath or otherwise and adjust its height so that the closed end of the capillary is near the middle of the thermometer bulb. Replace the thermometer and continue the heating, with constant stirring, sufficiently to cause the temperature to rise at a rate of about 10° per minute. Continue the heating and note the temperature at which the column of the sample collapses definitely against the side of the tube at any point, when melting may be considered to have begun and note also the temperature at which the sample becomes liquid throughout as seen by the formation of a definite meniscus. The two temperatures fall within the limits of the melting range.

### Method II

#### Apparatus

Use the apparatus described under Method I except that the glass capillary tube is open at both ends and has an internal diameter of 1.1 to 1.3 mm, an external diameter of 1.4 to 1.7 mm and length of 50 to 60 mm.

#### Procedure

Rapidly melt the substance under examination, at a temperature not more than 10° above the point of complete fusion. Draw it into a capillary tube to a depth of about 10 mm. Cool the

charged tube at 10° or lower for 24 hours, or keep in contact with ice for at least 2 hours. Attach the tube to the thermometer and adjust it so that the column of the substance under examination is in level with the thermometer bulb. Suspend the thermometer in the heating vessel containing water at 15° so that the lower end of the column of the substance is 30 mm below the surface of the water and heat the water with constant stirring so that the temperature rises at the rate of 1° per minute. The temperature at which the partly melted substance is observed to rise in the capillary tube is the melting temperature.

### Method III

#### Apparatus

- (a) A glass boiling-tube of overall length 110 mm and internal diameter 25 mm.
- (b) A cork about 25 mm long to fit into the boiling-tube, bored with a central hole to fit a standard thermometer and with a groove cut in the side.
- (c) A glass beaker of such a size that when the apparatus is assembled the boiling-tube can be immersed vertically to two-thirds of its length in the water in the beaker with its lower end about 2.5 cm above the bottom of the beaker.
- (d) A stirrer or any other device which will ensure uniformity of the temperature throughout the water in the beaker.
- (e) An accurately standardised thermometer suitable for the substance under examination (see Appendix 2.1.4).
- (f) Suitable means for heating the water in the beaker.

#### Procedure

Melt a quantity of the substance under examination slowly, while stirring, until it reaches a temperature of about 90°. Cool and allow the temperature of molten substance to drop to a temperature 8° to 10° above the expected melting temperature. Chill the bulb of the thermometer to 5°, wipe it dry and while it is still cold dip it in the molten substance so that the lower half of the bulb is submerged. Withdraw it immediately, and hold it vertically away from the heat until the wax surface dulls, then dip it for 5 minutes into a water bath at a temperature not higher than 15°.

Fit the thermometer through the bored cork into the boiling-tube so that the lower part is 15 mm above the bottom of the tube. Suspend the tube in the beaker filled with water adjusted to about 15° and raise the temperature of the bath to 30° at the rate of 2° per minute, adjust the rate to 1° per minute and note the temperature at which the first drop of melted substance leaves the thermometer. Repeat the determination twice on a freshly melted portion of the substance. If the three readings differ by less than 1°, take the average of the three as the melting temperature. If they differ by more than 1°, make two additional determinations and take the average of the five readings.

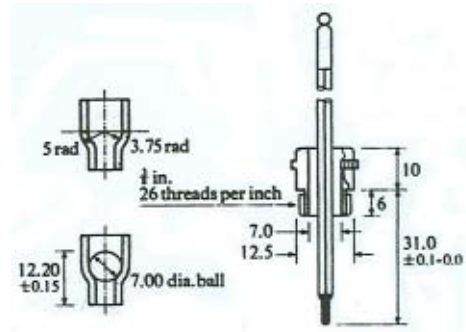
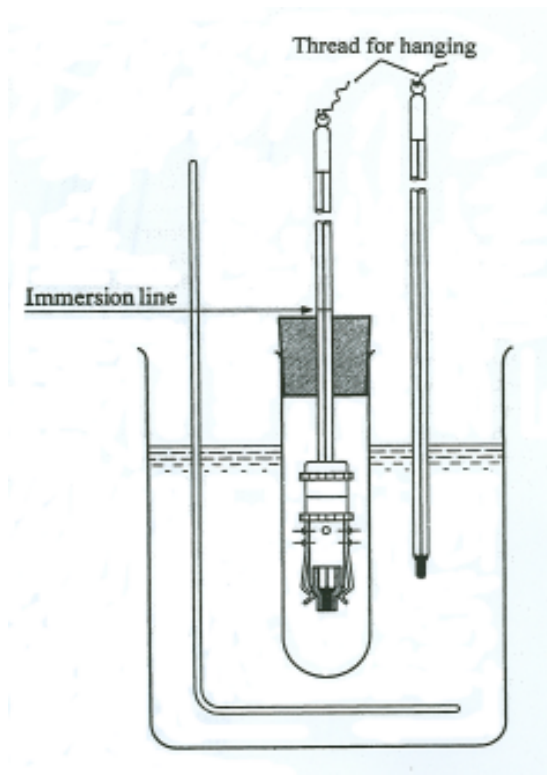

Fig. 2.4.21-1a  
Cup

Fig. 2.4.21-1b  
Relative position of  
Thermometer and sleeve

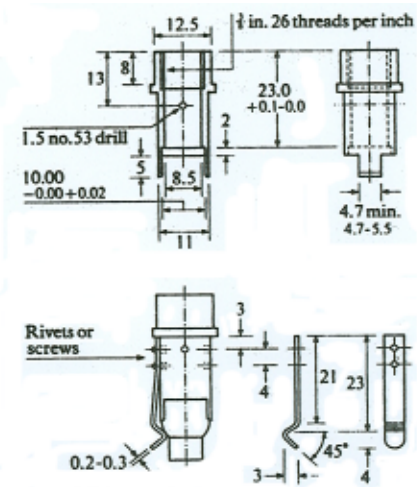

Fig. 2.4.21-1c  
Cup

General assembly (*Dimensions in mm*)

Fig. 2.4.21-1: Apparatus for Determination of Melting Range or Temperature

**Method IV**

**Apparatus**

The apparatus (see Fig. 2.4.21-1) consists of the following components:

- (a) An accurately standardised thermometer calibrated for 100-mm immersion, covering the range  $-5^{\circ}$  to  $+105^{\circ}$ , and conforming to Indian Standard 4825:1968 but with the following modifications:

- Bulb diameter 3.35 to 3.65 mm
- Bulb length not greater than 5 mm

Stem diameter, immediately above the bulb, approximately equal but not less than the diameter of the bulb for a length of at least 26 mm measured from the bottom of the bulb.

- b) A metal cup (see Fig.2.4.21-1a) made from chromium-plated brass or from other suitable metal which is not susceptible to corrosion by the substance under examination and conforming to the following dimensions:

Internal diameter of wide part of cup	7.35 to 7.65 mm
External diameter of wide part of cup	9.95 to 9.99 mm
Internal diameter of orifice	3.1 to 3.2 mm
External diameter of orifice	5.5 to 5.6 mm
Overall length of cup	15.0 to 15.4 mm

Internal depth of wide part of the cup: The lower part of the wide portion of the cup is approximately part of a hemisphere. When a steel ball, 7.00 mm in diameter is placed in the cup, the top of the ball is 12.05 to 12.35 mm above the bottom of the tube forming the orifice. The top of the cup and the bottom of the tube forming the orifice are smooth, parallel to each other and at right angles to the axis of the cup. The bottom edge of the orifice is not chamfered or radiused.

- c) To the lower end of the thermometer is securely and coaxially cemented a cylindrical metal sleeve on to which

a metal case is screwed (see Figs 2.4.21-1b and 2.4.21c). This metal case has two small apertures, one in front and one behind, to act as air vents. It also has a rim stop, guide lugs to aid the coaxial insertion of the cup into the case and spring clips to enable the cup to be retained firmly with its top edge against the rim stop. The metal sleeve is fixed to the thermometer in such a position that, when the metal case is screwed on to the sleeve, the bottom of the thermometer bulb is 7.9 to 8.2 mm below the rim stop.

- d) Auxiliary apparatus assembled as shown in Fig 2.4.21-1 and consisting of the following parts.
- (i) A glass tube, overall length, 110 mm, internal diameter, 25 mm.
  - (ii) A cork about 25 mm long, bored with a central hole to fit the standard thermometer and with a groove cut in the side.
  - (iii) A glass beaker, of such size that when the apparatus is assembled the boiling tube can be immersed vertically to two third of its length in the liquid in the beaker with its lower end about 25 mm above the bottom of the beaker. The liquid used in the beaker should be water for melting points (flow and drop points) below 80° and liquid paraffin or glycerin for melting points above 80°.
  - (iv) A stirrer or any other convenient device that will ensure uniformity of temperature through out the liquid in the beaker.
  - (v) An auxiliary thermometer.
  - (vi) A stand with clamps for holding the boiling tube and auxiliary thermometer in position in the beaker and for holding the beaker above the source of heat.
  - (vii) A suitable means of heating the water in the beaker.

### Procedure

Heat the sample, with stirring, to 118° to 122°, to ensure uniformity, and then cool to 103° to 107°. Warm the metal cup to 103° to 107° in an oven, remove it from the oven, place on a clean plate or ceramic tile and pour sufficient of the melted sample into the cup to fill it completely. Allow the filled cup to cool for 30 minutes on the tile or plate and then place it in a water-bath at 24° to 26° for a further 30 to 40 minutes. Level the surface of the sample with a single stroke of a knife or razor blade, avoiding any stirring of the sample. Push the cup, without lateral movement, into the metal case as far as the rim stop and wipe away the excess of the substance that is squeezed out of the bottom of the tube, ensuring that the air vents are not blocked. Fit the thermometer, with the cup attached, through the bored cork to the boiling tube such that the bottom of the cup is 24 to 26 mm above the bottom of the boiling tube. Fix the boiling tube vertically within the beaker

so that at least two thirds of its length is immersed in the liquid contained in the beaker. Adjust the temperature of the outer bath so that the temperature of the substance rises at the rate of 1° per minute. The temperature at which the first drop of melted liquid falls from the metal cup is regarded as the melting point (drop point) of the substance. Note the temperature at the fall of the first drop. Carry out at least three determinations, each time with a fresh sample of the substance under examination. The difference between the readings must not exceed 3°. The mean of three readings is taken as the melting point of the substance.

### 2.4.22 Optical Rotation and Specific Optical Rotation

Optical rotation, ' $\alpha$ ' is the property shown by certain substances of rotating the plane of polarisation of polarised light. Such substances are said to be optically active in the sense that they cause incident polarised light to emerge in a plane forming a measurable angle with a plane of the incident light. Where this effect is large enough for measurement, it may serve as the basis for identifying or assaying a substance.

The optical rotation of a substance is the angle through which the plane of polarisation is rotated when polarised light passes through the substance, if liquid, or a solution of the substance. Substances are described as *dextro*-rotatory or *laevo*-rotatory according to whether  $[\alpha]_D^{25}$  the plane of polarisation is rotated clockwise or anticlockwise, respectively as determined by viewing towards the light source. *Dextro*-rotation is designated (+) and *laevo*-rotation is designated (-).

The optical rotation, unless otherwise specified, is measured at the wavelength of the D line of sodium ( $\lambda = 589.3$  nm) at 25°, on a layer 1 dm length. It is expressed in degrees.

The specific optical rotation,  $[\alpha]_D^{25}$ , of a liquid substance is the angle of rotation, ' $\alpha$ ', of the plane of polarisation at the wavelength of the D line of sodium ( $\lambda = 589.3$  nm) measured at 25°, unless otherwise specified, calculated with reference to a 1-dm thick layer of the liquid, and divided by the *specific gravity* at 25°.

The specific optical rotation,  $[\alpha]_D^{25}$ , of a solid substance is the angle of rotation, ' $\alpha$ ', of the plane of polarisation at the wavelength of the D line of sodium ( $\lambda = 589.3$  nm) measured at 25°, unless otherwise specified, calculated with reference to a 1-dm thick layer of a solution containing 1 g of the substance per ml. The specific optical rotation of a solid is always expressed with reference to a given solvent and concentration.

### Apparatus

A commercial instrument constructed for use with a sodium lamp and capable of giving readings to the nearest 0.02° is suitable for most purposes. For certain applications, the use

of a photoelectric polarimeter capable of taking measurements at the specific wavelengths may be necessary.

The accuracy and precision of optical rotation measurements can be increased if the following precautions are taken.

- The instrument must be in a good condition. The optical elements must be very clean and in exact alignment. The match point should be close to the normal zero mark.
- The light source should be properly aligned with respect to the optical bench. It should be supplemented by a filtering system capable of isolating the D line from sodium light.
- Specific attention should be paid to temperature control of the solution and of the polarimeter.
- Differences between the initial readings or between observed and corrected optical rotation, calculated as either specific optical rotation or optical rotation, should not be more than one-fourth of the range specified in the monograph for the substance.
- Polarimeter tubes should be filled in such a way as to avoid air bubbles. Particular care is necessary for semi-micro or micro tubes.
- For tubes with removable end-plates fitted with gaskets and caps, tighten the end-plates only enough to ensure a leak-proof seal between the end-plate and the body of the tube.
- For substances with low rotatory power, the end-plates should be loosened and tightened again after each reading, in the measurement of both the rotation and the zero point.
- Liquids and solutions of solids must be clear.

#### Calibration

The apparatus may be checked by using a solution of previously dried *sucrose* and measuring the optical rotation in a 2-dm tube at 25° and using the concentrations indicated in the table.

Table

Concentration (g/100 ml)	Angle of Rotation (+) at 25°
10.0	13.33
20.0	26.61
30.0	39.86
40.0	53.06
50.0	66.23

#### Method

**For solids** — Weigh accurately a suitable quantity of the substance under examination to obtain the solution of the strength specified in the individual monograph and transfer

to a volumetric flask by means of *water* or other solvent, if specified. If a solvent is used, reserve a portion of it for the blank determination. Unless otherwise specified, adjust the contents of the flask to 25° by suspending the flask in a constant-temperature bath. Make up to volume with the solvent at 25° and mix well. Transfer the solution to the polarimeter tube within 30 minutes from the time the substance was dissolved and during this time interval maintain the solution at 25°.

Determine the zero point of the polarimeter and then make five readings of the observed rotation of the test solution at 25°. Take an equal number of readings in the same tube with the solvent in place of the test solution. The zero correction is the average of the blank readings, and is subtracted from the average observed rotation if the two figures are of the same sign or added if they are opposite in sign to obtain the corrected observed rotation.

**For liquids** — Unless otherwise specified, adjust the temperature of the substance under examination to 25°, transfer to a polarimeter tube and proceed as described For solids, beginning at the words “Determine the zero point...”.

#### Calculations

Calculate the specific optical rotation using the following formulae, *dextro*-rotation and *laevo*-rotation being designated by (+) and (-) respectively.

$$\text{For liquids } [\alpha]_D^{25} = \alpha / ld^{25}$$

$$\text{For solids } [\alpha]_D^{25} = 100\alpha / lc$$

where  $\alpha$  = corrected observed rotation, in degrees, at 25°

D = D line of sodium light ( $\lambda = 589.3 \text{ nm}$ )

$l$  = length of the polarimeter tube in dm

$d_{25}^{25}$  = specific gravity of the liquid or solution at 25°

$c$  = concentration of the substance in per cent w/v

**NOTE** — The requirement for optical rotation and specific optical rotation in the *Pharmacopoeia* apply to a dried, anhydrous or solvent-free material in all those monographs in which standards for loss on drying, water, or solvent content respectively are given. In calculating the result, the loss on drying, water or solvent content determined by the method specified in the monograph is taken into account.

#### 2.4.23. Osmolality

The expression of concentration of electrolytes in terms of mass concentrations such as mg per litre is of little clinical value. The earlier practice of expressing in terms of milliequivalents (mEq) per litre has now been replaced by molar



or more correctly, the osmolar concentrations of electrolyte solutions and parenteral fluids. Knowledge of the osmolar concentration indicates whether a solution is hypo-osmotic, iso-osmotic or hyper-osmotic.

A quantitative statement of osmolar concentration facilitates calculation of the dilution required to render a hyper-osmotic solution iso-osmotic. It also simplifies many calculations involved in peritoneal dialysis and haemodialysis procedure.

Osmolality is a means of measuring the contribution of the various solutes present in a solution to the osmotic pressure of the solution.

The unit of osmolality is osmole per kilogram (osmol/kg). An osmol is defined as the weight in grams of a solute, existing in solution as molecules (and/or ions, macro-molecules, aggregates etc.) that is osmotically equivalent to the gram-molecular-weight (mole) of an ideally behaving nonelectrolyte. Thus the osmol-weight of a nonelectrolyte, in a dilute solution, is generally equal to its gram-molecular weight. A milliosmol, abbreviated as mOsmol, is the weight stated in milligrams and is the unit usually used.

The units of osmolar concentration are usually expressed as milliosmols (mOsmols) of solute per litre of solution. The osmolar concentration may be calculated from one of the following equations

For a nonelectrolyte:

$$\frac{\text{g/litre}}{\text{mol.wt.}} \times 100 = \text{mOsmol/litre}$$

For strong electrolyte:

$$\frac{\text{g/litre}}{\text{mol.wt.}} \times \text{number of ions formed} \times 1000 = \text{mOsmol/litre}$$

For individual ions, if desired:

$$\frac{\text{g of ion/litre}}{\text{ionic wt.}} \times 1000 = \text{mOsmol (of ion)/litre}$$

These are simple calculations; however, they omit consideration of factors such as solvation and inter-ionic forces. By this method of calculation, a 0.9 per cent w/v solution of *sodium chloride* has an osmolar concentration of 308 mOsmols per litre ( $9/58.4 \times 2 \times 1000$ ). This is the ideal osmolar concentration. In fact, the number of ions is slightly less than 2 for solutions of sodium chloride at this concentration, and the actual measured osmolarity of 0.9 per cent w/v Sodium Chloride Injection is about 286 mOsmols per litre. In general, as the concentration of the solute increases, interaction among solute particles increases and the actual osmolar values decrease when compared to the ideal values. Deviation from ideal conditions is usually slight in solutions within the physiologic range and for more dilute solutions, but for highly concentrated solutions the actual osmolarities may be appreciably lower than ideal values.

The derivation of the osmolar concentrations from the stated composition of the solution may be verified by calculations using the equations given above. The osmolarity of a mixture of complex composition such as Protein Hydrolysate Injection cannot be readily and confidently calculated. In such instance, actual values of osmolar concentration are determined by calculating the osmolarity from measured values of osmolal concentration and water content. Each osmol of solute added to 1 kg of water lowers the freezing point approximately  $1.86^\circ$  and lowers the vapour pressure approximately 0.3 mm of mercury at  $25^\circ$ . These physical changes are measurable and they permit accurate measurements of osmolal concentrations.

Unless otherwise directed, osmolality is determined by measurement of the depression of freezing point  $\Delta T$ . The osmolality ( $\xi_m$ ) in mosmol per kg is calculated from the expression

$$\frac{\Delta T \times 1000}{1.86}$$

**Apparatus.** It consists of a system of cooling the container used for the measurement, an arrangement for mixing the sample, and a system for measuring the temperature by means

Table

Wt. in g of sodium chloride per kg of water	Real osmolality (mosmol/kg)	Ideal osmolality (mosmol/kg)	Molal osmolality Coefficient	Cryoscopic depression ( $^\circ\text{C}$ )
3.087	100	105.67	0.9463	0.186
6.260	200	214.20	0.9337	0.372
9.463	300	323.83	0.9264	0.558
12.684	400	434.07	0.9215	0.744
15.916	500	544.66	0.9180	0.930
19.147	600	655.24	0.9157	1.116
22.380	700	765.86	0.9140	1.302



of a device for determining the current or potential-difference, graduated in temperature depression or directly in osmolality.

**Method.** Prepare the required reference solutions given in the table. Determine the zero of the apparatus using water. Calibrate the apparatus using the reference solutions in the following manner. Introduce 50 µl to 250 µl of the sample into the measurement cell and start the cooling. Operate the cooling device at a temperature below that expected through cryoscopic depression to prevent supercooling. When equilibrium is attained record the freezing point. Before each measurement, rinse the measurement cell with the solution to be examined. The instrument is calibrated by using two standard solutions of sodium chloride that span the expected range of osmolarities.

Carry out the same operations with the test sample. Read directly the osmolality or calculate it from the measured depression of freezing point. The test is not valid unless the value found is within two values of the calibration scale.

## 2.4.24 pH Values

The pH value conventionally represents the acidity or alkalinity of an aqueous solution. In the Pharmacopoeia, standards and limits of pH have been provided for those pharmacopoeial substances in which pH as a measure of the hydrogen-ion activity is important from the standpoint of stability or physiological suitability. The determination is carried out at a temperature of  $25^{\circ} \pm 2^{\circ}$ , unless otherwise specified in the individual monograph.

### Apparatus

The pH value of a solution is determined potentiometrically by means of a glass electrode, a reference electrode and a pH meter either of the digital or analogue type.

Operate the pH meter according to the manufacturer's instructions. Calibrate the apparatus using *buffer solution D* as the primary standard, adjusting the meter to read the appropriate pH value given in the table, corresponding to the

temperature of the solution. To set the scale, use a second reference buffer solution, either *buffer solution A*, *buffer solution E* or *buffer solution G* and carry out a check with a third buffer solution of intermediate pH. The pH reading of the intermediate solution must not differ by more than 0.05 from the corresponding value indicated in the table.

### Reference Buffer Solutions

*NOTE*— Prepare the following buffer solutions using carbon dioxide-free water. Buffer solutions should be stored in bottles made of alkali-free glass, and must not be used later than 3 months after preparation.

- A 1.271 per cent w/v solution of *potassium tetraoxalate*.
- A freshly prepared solution, saturated at  $25^{\circ}$ , of *potassium dihydrogen tartrate*.
- A freshly prepared 1.151 per cent w/v solution of *potassium dihydrogen citrate*.
- A 1.021 per cent w/v solution of potassium hydrogen phthalate, previously dried at  $110^{\circ}$  to  $135^{\circ}$  for 2 hours.
- A mixture containing 0.348 per cent w/v of potassium dihydrogen phosphate and 0.355 per cent w/v of anhydrous disodium hydrogen phosphate, both previously dried at  $110^{\circ}$  to  $130^{\circ}$  for 2 hours.
- A mixture containing 0.1184 per cent w/v of potassium dihydrogen phosphate and 0.4303 per cent w/v of anhydrous disodium hydrogen phosphate, both previously dried at  $110^{\circ}$  to  $130^{\circ}$  for 2 hours.
- A 0.3814 per cent w/v solution of *sodium tetraborate* stored protected from carbon dioxide.
- A mixture containing 0.2649 per cent w/v of *sodium carbonate* and 0.210 per cent w/v of *sodium bicarbonate*.
- Shake on excess of *calcium hydroxide* with *carbon dioxide-free water* and decant at  $25^{\circ}$ .

### Method

Immerse the electrodes in the solution under examination and measure the pH at the same temperature as for the standard

Table - pH of reference buffer solutions at various temperatures

Temperature t°	Reference Buffer Solution								
	A	B	C	D	E	F	G	H	I
15	1.67	–	3.80	4.00	6.90	7.45	9.28	10.12	12.81
20	1.68	–	3.79	4.00	6.88	7.43	9.23	10.06	12.63
25	1.68	3.56	3.78	4.01	6.87	7.41	9.18	10.01	12.45
30	1.68	3.55	3.77	4.02	6.85	7.40	9.14	9.97	12.29
35	1.69	3.55	3.76	4.02	6.84	7.39	9.10	9.93	12.13
ΔpH/Δt	+0.001	–0.0014	–0.0022	+0.0012	–0.0028	–0.0028	–0.0082	–0.0096	–0.034

solutions. At the end of a set of measurements, record the pH of the solution used to standardise the meter and the electrodes. If the difference between this reading and the original value is greater than 0.05, the set of measurements must be repeated.

When measuring pH values above 10.0 ensure that the glass electrode is suitable for use under alkaline conditions and apply any correction that is necessary.

All solutions and suspensions of substances under examination must be prepared using *carbon dioxide-free water*.

### 2.4.25. Potentiometric Titration

A convenient and useful method of determining the equivalence point of a titration, i.e the point at which the stoichiometric analytical reaction is complete, results from the use of electrochemical measurements. If an indicator electrode, sensitive to the concentration of the chemical undergoing titrimetric reaction, and a reference electrode, whose potential is not sensitive to any dissolved chemical in solution, are immersed in the solution under examination to form a galvanic cell, the potential difference between the electrodes may be sensed by a simple potentiometer or electronic device and used to follow the course of the reaction. If a graph of the variation of potential difference is plotted as a function of the quantity of the titrant added, a sigmoid curve results with a rapidly changing portion in the vicinity of the equivalence point. The mid - point of this linear vertical portion or the inflection point may taken as the end - point of the titration.

In a titrimetric assay the end - point determination is an estimate of the reaction equivalence point. The validity of this estimate depends upon, among other factors, the nature of the solution being titrated and the concentration of the titrant. A blank correction is employed in titrimetric assays to enhance the reliability of the end - point determination. With Potentiometric titrations the blank correction is usually negligible.

#### Apparatus

The apparatus used comprises a voltmeter allowing readings to the nearest millivolt. the choice of the electrode system is governed by the nature of the titration. Table 1 summarises several acceptable electrode systems.

Automatic titrators are commonly employed these days. Two types of instruments are available. In the first one addition of titrant is carried out automatically and the electrode potential differences during the course of titration are recorded as the expected sigmoid curve. In the second type, titrant addition is performed automatically until or preset potential or pH, representing the end - point, is reached when the addition of the titrant ceases.

#### Method

Plot a graph of the variations of potential difference versus the volume of the titrant added, continuing the addition of the titrant beyond the presumed equivalence point. The end - point corresponds to a sharp variation of potential difference. Perform a blank titration by repeating the procedure in the same manner omitting the substance under examination. The actual volume of titrant equivalent to the substance under examination is the difference between the volume consumed in the blank titration and that consumed in the titration with the substance under examination.

### 2.4.26. Solubility

*NOTE* - A test for solubility becomes a test for purity only where a special quantitative test is given in the individual monograph and is an official requirement.

The approximate solubilities of the articles of the Pharmacopoeia are given here primarily as information; they are not meant to be applied as tests for identifying materials. However, they may indirectly help in the preliminary evaluation of the integrity of an article. They have been indicated by descriptive terms in the accompanying table and have the following significance with reference to a temperature of 15° to 30°.

Table 1

Titration	Indicating Electrode	Reference Electrode	Applicability
Acid-base	Glass	Calomel or silver-silver chloride	Titration of acids and bases
Precipitometric	Silver	Calomel (with potassium nitrate salt bridge)	Titration with or of silver involving halides or thiocyanate
Chelometric	Mercury-mercury(II)	Calomel	Titration of metals with disodium edetate
Oxidation-reduction	Platinum	Calomel or silver-silver chloride	Titration with bromine, dichromate nitrite, etc.

Descriptive term	Parts of Solvent required for Part of Solute
Very soluble	Less than 1
Freely soluble	From 1 to 10
Soluble	From 10 to 30
Sparingly soluble	From 30 to 100
Slightly soluble	From 100 to 1000
Very slightly soluble	From 1000 to 10,000
Practically insoluble, or Insoluble	10,000 or more

**Abacavir Sulphate.** Soluble in *water*.

**Acacia and Acacia Powder.** Almost entirely soluble in twice its weight of *water* yielding a very viscous, slightly acidic solution which is slightly glairy and, when diluted with more *water* and allowed to stand, yields a very small amount of gummy deposit; practically insoluble in *ethanol* (95 per cent) and in *ether*.

**Acarbose.** Very soluble in *water*; soluble in *methanol*; practically insoluble in *methylene chloride*.

**Acebutolol Hydrochloride.** Freely soluble in *water* and in *ethanol* (95 per cent); very slightly soluble in *acetone* and in *dichloromethane*; practically insoluble in *ether*.

**Aceclofenac.** Practically insoluble in *water*; freely soluble in *acetone*; soluble in *ethanol* (95 per cent).

**Acepromazine Maleate.** Freely soluble in *dichloromethane* soluble in *water* and in *ethanol* (95 per cent); slightly soluble in *ether*.

**Aciclovir.** Freely soluble in *dimethyl sulphoxide*; slightly soluble in *water*; very slightly soluble in *ethanol* (95 per cent). It dissolves in dilute solutions of mineral acids and alkali hydroxides.

**Adenine.** Very slightly soluble in *water* and in *ethanol* (95 per cent); practically insoluble in *ether*. It is soluble in dilute acids and in dilute alkalis.

**Adrenaline Bitartrate.** Freely soluble in *water*; slightly soluble in *ethanol* (95 per cent); practically insoluble in *chloroform* and in *ether*.

**Adrenaline.** Sparingly soluble in *water*; insoluble in *ethanol* (95 per cent) and in *ether*. It is soluble in solutions of mineral acids, of *sodium hydroxide* and of *potassium hydroxide* but not in solutions of ammonia and of the alkali carbonates. It is not stable in a neutral or alkaline which rapidly becomes red on exposure to air.

**Albendazole.** Freely soluble in *formic acid*; and in *dimethylformamide*; sparingly soluble in *methanol* and in *chloroform*; very slightly soluble in *methanol*. It is soluble in dilute acids and in solutions of alkalis.

**Alginic Acid.** Insoluble but swells in *water*; practically insoluble or very slightly soluble in *ethanol* (95 per cent) and in organic solvents. It is soluble in alkaline solutions.

**Allopurinol.** Very slightly soluble in *water* and in *ethanol* (95 per cent); practically insoluble in *chloroform* and in *ether*. It is soluble in dilute solutions of alkali hydroxides.

**Aloes.** Soluble in hot *ethanol* (95 per cent); partly soluble in boiling *water*; practically insoluble in *chloroform* and in *ether*. Powdered Aloes is almost entirely soluble in *ethanol* (60 per cent).

**Alprazolam.** Freely soluble in *chloroform*; soluble in *ethanol* (95 per cent); sparingly soluble in *acetone*; slightly soluble in *ethyl acetate*; insoluble in *water*.

**Aluminium Hydroxide Gel, Dried.** Insoluble in *water* and in *ethanol* (95 per cent). It dissolves in dilute mineral acids and in excess of caustic alkali solutions.

**Aluminium sulphate.** Soluble in *water*; freely soluble in hot *water*; practically insoluble in *ethanol* (95 per cent).

**Amantadine Hydrochloride.** Freely soluble in *water* and in *ethanol* (95 per cent); soluble in *chloroform*; practically insoluble in *ether*.

**Ambroxol Hydrochloride.** Sparingly soluble in *water*; soluble in *methanol*; practically insoluble in *methylene chloride*.

**Amikacin.** Sparingly soluble in *water*.

**Amikacin Sulphate.** Freely soluble in *water*; practically insoluble in *methanol*, in *acetone*, in *ether* and in *chloroform*.

**Amiloride Hydrochloride.** Slightly soluble in *water* and in *ethanol* (95 per cent); practically insoluble in *chloroform* and in *ether*.

**Aminocaproic Acid.** Freely soluble in *water*; slightly soluble in *ethanol* (95 per cent) and in *methanol*; practically insoluble in *chloroform* and in *ether*. It is soluble in acids and in alkalis.

**Aminophylline.** Freely soluble in *water* (the solution usually becomes turbid on standing); practically insoluble in *ethanol* and in *ether*.

**Amitraz.** Freely soluble in *acetone*; practically insoluble in *water*. Decomposes slowly in *ethanol* (95 per cent).

**Amitriptyline Hydrochloride.** Freely soluble in *water*, in *ethanol* (95 per cent), in *chloroform* and in *methanol*; practically insoluble in *ether*.

**Amlodipine Besilate.** Slightly soluble in *water*; freely soluble in *methanol*; sparingly soluble in *ethanol* (95 per cent); slightly soluble in *2-propanol*.

**Ammonium Chloride.** Freely soluble in *water*; sparingly soluble in *ethanol* (95 per cent).

**Amodiaquine Hydrochloride.** Soluble in *water*; sparingly soluble in *ethanol* (95 per cent); practically insoluble in *chloroform* and in *ether*.

**Amoxicillin Sodium.** Very soluble in *water*; sparingly soluble in *ethanol*; very slightly soluble in *acetone*; practically insoluble in *chloroform* and in *ether*.

**Amoxicillin Trihydrate.** Slightly soluble in *water*, in *ethanol* (95 per cent) and in *methanol*; practically insoluble in *chloroform*, in *ether* and in fixed oils. It is soluble in dilute solutions of acids and of alkali hydroxides.

**Amphotericin B.** Soluble in *dimethyl sulphoxide*; slightly soluble in *dimethylformamide* and in *methanol*; insoluble in *benzene*, in *ethanol* (95 per cent), in *ether* and in *water*.

**Ampicillin.** Sparingly soluble in *water*; practically insoluble in *ethanol*, in *chloroform*, in *ether* and in fixed oils. It is soluble in dilute solutions of acids and of alkali hydroxides.

**Ampicillin Sodium.** Freely soluble in *water*; sparingly soluble in *acetone*; slightly soluble in *chloroform*; practically insoluble in *ether*; in liquid paraffin and in fixed oils.

**Ampicillin Trihydrate.** Slightly soluble in *water*; practically insoluble in *ethanol* (95 per cent), in *chloroform*, in *ether* and in fixed oils. It is soluble in dilute solution of acids and of alkali hydroxides.

**Amprolium Hydrochloride.** Freely soluble in *water*; slightly soluble in *ethanol* (95 per cent); very slightly soluble in *ether*; practically insoluble in *dichloromethane*.

**Arteether.** Soluble in *acetone*, *dichloromethane*, *ethyl acetate*, *hexane* and *methanol*.

**Artemether.** Very soluble in *dichloromethane* and *acetone*; freely soluble in *ethylacetate* and practically insoluble in *water*.

**Artemisinin.** Practically insoluble in *water*; freely soluble in *acetonitrile*, *chloroform*, *dichloromethane*, *ethyl acetate*, *methanol*, *ethanol* (95 per cent) and *glacial acetic acid*.

**Aspirin.** Freely soluble in *ethanol* (95 per cent); soluble in *chloroform* and in *ether*; slightly soluble in *water*.

**Atenolol.** Soluble in *ethanol*; sparingly soluble in *water*; slightly soluble in *dichloromethane*; practically insoluble in *ether*.

**Atorvastatin Calcium.** Very slightly soluble in *water*, *acetonitrile*; slightly soluble in *ethanol* (95 per cent) and freely soluble in *methanol*.

**Atropine Methonitrate.** Freely soluble in *water*; soluble in *ethanol* (95 per cent); practically insoluble in *chloroform* and in *ether*.

**Atropine Sulphate.** Very soluble in *water*; freely soluble in *ethanol* (95 per cent) and in *glycerin*; practically insoluble in *chloroform* and in *ether*.

**Azathioprine.** Practically insoluble in *water* and in *ethanol* (95 per cent). It is soluble in dilute solutions of *alkali hydroxides* and sparingly soluble in *dilute mineral acids*.

**Azithromycin.** Practically insoluble in *water* and in *ethanol* (95 per cent). It is soluble in dilute solutions of *alkali hydroxides* and sparingly soluble in *dilute mineral acids*.

**Bacitracin.** Freely soluble in *water* and in *ethanol* (95 per cent); soluble in *methanol* and in *glacial acetic acid*; practically insoluble in *acetone*, in *chloroform* and in *ether*.

**Bacitracin Zinc.** Slightly soluble in *water* and in *ethanol* (95 per cent); very slightly soluble in *ether*; insoluble in *chloroform*.

**Baclofen.** Slightly soluble in *water*; very slightly soluble in *ethanol* (95 per cent); practically insoluble in *acetone*. It dissolve in *dilute mineral acids* and in dilute solutions of *alkali hydroxides*.

**Beclomethasone Dipropionate.** Freely soluble in *acetone* and in *chloroform*; sparingly soluble in *ethanol* (95 per cent); practically insoluble in *water*.

**Beeswax, White.** Partially soluble in hot *ethanol* (90 per cent) and in *ether*; practically insoluble in *water*; completely soluble in volatile and fixed oils.

**Beeswax, Yellow.** Partially soluble in hot *ethanol* (90 per cent) and in *ether*; practically insoluble in *water*; completely soluble in volatile and fixed oils.

**Bentonite.** Insoluble in *water* but swells into a homogeneous mass; insoluble in, and does not swell in, organic solvents.

**Benzalkonium Chloride Solution.** Miscible with *water* and with *ethanol* (95 per cent).

**Benzathine Penicillin.** Freely soluble in *formamide* and *dimethylformamide*; slightly soluble in *ethanol* (95 per cent); very slightly soluble in *chloroform* and in *water*; practically insoluble in *ether*.

**Benzhexol Hydrochloride.** Soluble in *ethanol* (95 per cent), in *methanol* and in *chloroform*; slightly soluble in *water*.

**Benzocaine.** Freely soluble in *ethanol* (95 per cent), in *chloroform* and in *ether*; very slightly soluble in *water*. It is soluble in dilute acids.

**Benzoic Acid.** Freely soluble in *ethanol* (95 per cent), in *chloroform* and in *ether*; slightly soluble in *water* but soluble in boiling *water*. It is soluble in fixed oils.

**Benzyl Benzoate.** Soluble in *ethanol* (95 per cent), in *chloroform* and in *ether*; practically insoluble in *water*; insoluble in *glycerin*.

**Benzylpenicillin Potassium.** Very soluble in *water*; practically insoluble in *chloroform*, in *ether*, in fixed oils and in *liquid paraffin*.

**Benzylpenicillin Sodium.** Very soluble in *water*; practically insoluble in *chloroform*, in *ether*, in fixed oils and in *liquid paraffin*.

**Betahistine Hydrochloride.** Very soluble in *water*; soluble in *ethanol* (95 per cent); practically insoluble in *2-propanol*.



**Betamethasone.** Sparingly soluble in *ethanol* (95 per cent); very slightly soluble in *chloroform*; practically insoluble in *water*.

**Betamethasone Sodium Phosphate.** Freely soluble in *water*; slightly soluble in *ethanol* (95 per cent); practically insoluble in *chloroform*, in *dichloromethane* and in *ether*.

**Betamethasone Valerate.** Freely soluble in *chloroform*; soluble in *ethanol* (95 per cent); practically insoluble in *water* and in *light petroleum*.

**Biperiden Hydrochloride.** Slightly soluble in *water*, and in *ethanol* (95 per cent); very slightly soluble in *dichloromethane*; practically insoluble in *ether*.

**Bisacodyl.** Soluble in *acetone*, in *benzene* and in *chloroform*; sparingly soluble in *ethanol* (95 per cent) and in *methanol*; slightly soluble in *ether*; practically insoluble in *water*. It dissolves in dilute mineral acids.

**Bismuth Subcarbonate.** Practically insoluble in *water*, in *ethanol* (95 per cent) and in *ether*. It is soluble with effervescence in mineral acids.

**Bleomycin Sulphate.** Very soluble in *water*.

**Boric Acid.** Soluble in *water* and in *ethanol* (95 per cent); freely soluble in boiling *water*, in boiling *ethanol* (95 per cent) and in *glycerin* (85 per cent).

**Bromhexine Hydrochloride.** Sparingly soluble in *ethanol* (95 per cent) and in *methanol*; slightly soluble in *chloroform*; practically insoluble in *water*.

**Bromocriptine Mesylate.** Freely soluble in *methanol*; soluble in *ethanol* (95 per cent); sparingly soluble in *dichloromethane*; practically insoluble in *water*.

**Bronopol.** Soluble in *water*, *ethanol* (95 per cent), *ethyl acetate*. Slightly soluble in *chloroform*, *acetone*, *ether* and *benzene*.

**Budesonide.** Freely soluble in *methylene chloride*; sparingly soluble in *ethanol* (95 per cent).

**Bupivacaine Hydrochloride.** Freely soluble in *ethanol* (95 per cent); soluble in *water*; slightly soluble in *acetone*, in *chloroform* and in *ether*.

**Buprenorphine Hydrochloride.** Soluble in *methanol*; slightly soluble in *water* and in *chloroform*.

**Busulphan.** Freely soluble in *acetone*, in *chloroform*, and in *acetonitrile*; very slightly soluble in *water*, in *ethanol* (95 per cent) and in *ether*.

**Butylated Hydroxyanisole.** Freely soluble in *ethanol* (95 per cent), in *1,2-propanediol*, in *arachis oil* and in solutions of alkali hydroxides; practically insoluble in *water*.

**Butylated Hydroxytoluene.** Very soluble in *acetone*, in *chloroform* and in *ether*; freely soluble in *ethanol* (95 per cent), in *methanol*, in fixed oils and in fats; insoluble in *water*.

**Caffeine.** Freely soluble in *chloroform* and in boiling *water*; sparingly soluble in *water* and in *ethanol* (95 per cent); slightly soluble in *ether*.

**Calamine.** Insoluble in *water*. Practically completely soluble in mineral acids.

**Calciferol.** Freshly soluble in *ethanol* (95 per cent) in *chloroform* and *ether*; practically insoluble in *water*. It is soluble in fixed oils. Solutions in volatile solution are unstable and should be used immediately.

**Calcium Carbonate.** Practically insoluble in *water* and in *ethanol* (95 per cent); slightly soluble in *water* containing carbon dioxide or any ammonium salt. It is soluble with effervescence in dilute acids.

**Calcium Chloride.** Freely soluble in *water* and in *ethanol* (95 per cent).

**Calcium Folate.** Very soluble in *water*; practically insoluble in *ethanol* (95 per cent).

**Calcium Gluconate.** Sparingly soluble in *water* but freely soluble in boiling *water*; insoluble in *ethanol* (95 per cent).

**Calcium Lactate.** Soluble in *water* but freely soluble in hot *water*; very slightly soluble in *ethanol* (95 per cent).

**Calcium Levulinate.** Freely soluble in *water*; slightly soluble in *ethanol* (95 per cent); insoluble in *ether* and in *chloroform*.

**Calcium Pantothenate.** Freely soluble in *water*; soluble in *glycerin*; slightly soluble in *ethanol* (95 per cent); practically insoluble in *ether*.

**Dibasic Calcium Phosphate.** Practically insoluble in *water* and in *ethanol* (95 per cent) It dissolves in *dilute hydrochloric acid* and in *nitric acid*.

**Tribasic Calcium Phosphate.** Practically insoluble in *water* and in *ethanol* (95 per cent). It dissolves in *dilute hydrochloric acid* and in *nitric acid*.

**Calcium Stearate.** Practically insoluble in *water*, *ether*, *chloroform*, *acetone*; slightly soluble in *ethanol* (95 per cent).

**Calcium Sulphahte.** Soluble in *dilute hydrochloric acid*; slightly soluble in *water*.

**Captopril.** Freely soluble in *water*, in *methanol*, in *ethanol* (95 per cent) and in *chloroform*.

**Caramel.** Miscible with *water*, with dilute alcohols (up to 60 per cent v/v), with dilute mineral acids and with solutions of *sodium hydroxide*; miscible with *chloroform* and with *ether*. It is precipitated by strong alcohols (more than 60 per cent v/v).

**Carbamazepine.** Freely soluble in *dichloromethane*; sparingly soluble in *ethanol* (95 per cent) and in *acetone*; practically insoluble in *water* and in *ether*.

**Carbenicillin Sodium.** Freely soluble in *water*; soluble in *ethanol* (95 per cent); practically insoluble in *chloroform* and in *ether*.



**Carbenoxolone Sodium.** Freely soluble in *water*; soluble in *ethanol* (95 per cent); practically insoluble in *chloroform* and in *ether*.

**Carbidopa.** Slightly soluble in *water*; very slightly soluble in *ethanol* (95 per cent) and in *methanol*; practically insoluble in *acetone*, in *chloroform*, in *dichloromethane* and in *ether*. It is soluble in dilute solutions of mineral acids.

**Carbimazole.** Freely soluble in *chloroform*; soluble in *acetone*; sparingly soluble in *ethanol* (95 per cent); slightly soluble in *water* and in *ether*.

**Carbomers.** Soluble in *water*, soluble in *ethanol* (95 per cent).

**Carnauba Wax.** Soluble on warming in *chloroform*, in *ethyl acetate* and in *xylene*; practically insoluble in *water* and in *ethanol* (95 per cent).

**Castor Oil.** Miscible with *chloroform*, with *ethanol* (95 per cent), with *ether* and with *glacial acetic acid*; slightly soluble in *light petroleum*.

**Cefaclor.** Slightly soluble in *water*; practically insoluble in *methanol* and in *methylene chloride*.

**Cefadroxil.** Slightly soluble in *water*; practically insoluble in *ethanol* (95 per cent), in *chloroform* and in *ether*.

**Cefazolin Sodium.** Freely soluble in *water*; very slightly soluble in *ethanol* (95 per cent); practically insoluble in *chloroform* and in *ether*.

**Cefopرازone Sodium.** Freely soluble in *water*; soluble in *methanol*; slightly soluble in *ethanol* (95 per cent).

**Cefotaxime Sodium.** Freely soluble in *water*; practically insoluble in organic solvents.

**Ceftazidime.** Soluble in *dimethyl sulphoxide*; slightly soluble in *dimethylformamide*, in *methanol* and in *water*; insoluble in *acetone*, in *ethanol* (95 per cent), in *chloroform*, in *dioxan*, in *ethyl acetate*, in *ether* and in *toluene*. It is soluble in alkalis.

**Ceftriaxone Sodium.** Freely soluble in *water*; soluble in *methanol*; very slightly soluble in *ethanol* (95 per cent), *ether*, *ethylacetate* and *chloroform*.

**Cefuroxime Axetil.** Slightly soluble in *water*; soluble in *acetone*, *ethyl acetate* and *methanol*; slightly soluble in *ethanol* (95 per cent).

**Cefuroxime Sodium.** Soluble in *water*; sparingly soluble in *ethanol* (95 per cent); insoluble in *chloroform*, in *toluene*, in *ether*, in *ethyl acetate* and in *acetone*.

**Cellulose Acetate Phthalate.** Freely soluble in *acetone*; soluble in *diethylene glycol* and in *dioxan*; practically insoluble in *water*, in *ethanol* (95 per cent), in *toluene* and in chlorinated and non-chlorinated aliphatic hydrocarbons. It dissolves in dilute solutions of alkalis.

**Cephalexin.** Slightly soluble in *water*; practically insoluble in *ethanol* (95 per cent), in *chloroform* and in *ether*.

**Cephaloridine.** Slightly soluble in *water*; practically insoluble in *ethanol* (95 per cent), in *chloroform* and in *ether*.

**Cetirizine Hydrochloride.** Freely soluble in *water*; practically insoluble in *acetone* and in *methylene chloride*.

**Cetostearyl Alcohol.** Freely soluble in *ether*; soluble in *ethanol* (95 per cent) and in *light petroleum*; practically insoluble in *water*. When melted, it is miscible with fixed oils and with *liquid paraffin*.

**Cetrimide.** Freely soluble in *water*, in *ethanol* (95 per cent) and in *chloroform*; practically insoluble in *ether*.

**Cetyl Alcohol.** Freely soluble in *ether*; sparingly soluble in *ethanol* (95 per cent); practically insoluble in *water*. When melted, it is miscible with *liquid paraffin*, with animal vegetable oils and with melted *wool fat*.

**Activated Charcoal.** Practically insoluble in all usual solvents.

**Chlorambucil.** Freely soluble in *ethanol* (95 per cent), in *acetone* and in *chloroform*; practically insoluble in *water*.

**Chlorthalidone.** Soluble in *methanol*; slightly soluble in *ethanol* (95 per cent); practically insoluble in *water*, in *ether* and in *chloroform*. It is soluble in solutions of alkali hydroxides.

**Cholecalciferol.** Freely soluble in *ethanol* (95 per cent), in *acetone*, in *chloroform* and in *ether*; practically insoluble in *water*. It is soluble in fixed oils. Solutions in volatile solvents are unstable and should be used immediately.

**Chloramphenicol.** Freely soluble in *ethanol* (95 per cent) and in *1,2-propanediol*; slightly soluble in *water* and in *ether*.

**Chloramphenicol Palmitate.** Soluble in *acetone*, in *chloroform* and in *ether*; slightly soluble in *ethanol* (95 per cent); very slightly soluble in *hexane*; practically insoluble in *water*.

**Chloramphenicol Sodium Succinate.** Freely soluble in *water* and in *ethanol* (95 per cent); practically insoluble in *chloroform* and in *ether*.

**Chloral Hydrate.** Very soluble in *water*; freely soluble in *ethanol* (95 per cent), in *dichloromethane* and in *ether*.

**Chlorbutol.** Freely soluble in *ethanol* (95 per cent), in *ether*, in *chloroform* and in volatile oils; slightly soluble in *water*.

**Chlordiazepoxide.** Sparingly soluble in *ethanol* (95 per cent); slightly soluble in *ether*; practically insoluble in *water*.

**Chlorhexidine Diacetate.** Soluble in *ethanol* (95 per cent) and *propylene glycol*.

**Chlorhexidine Gluconate Solution.** Miscible with *water*; soluble in *ethanol* (95 per cent) and in *acetone*.

**Chlorhexidine Hydrochloride.** Sparingly soluble in *water* and *propylene glycol*; very slightly soluble in *ethanol* (95 per cent).

**Chlorocresol.** Very soluble in ethanol (95 per cent); freely soluble in *ether* and in fatty oils; slightly soluble in *water*. It dissolves in solutions of alkali hydroxides.

**Chloroform.** Miscible with *ethanol*, with *ether*, with most organic solvents and with fatty and volatile oils; slightly soluble in *water*.

**Chloroquine Phosphate.** Freely soluble in *water*; very slightly soluble in *chloroform*, in *ethanol* (95 per cent), in *ether* and in *methanol*.

**Chloroquine Sulphate.** Freely soluble in *water* and in *methanol*; very slightly soluble in *ethanol* (95 per cent); practically insoluble in *chloroform* and in *ether*.

**Chloroxyleneol.** Freely soluble in *ethanol* (95 per cent); soluble in *ether*, in terpenes and in fixed oils; very slightly soluble in *water*. It dissolves in solutions of alkali hydroxides.

**Chlorpheniramine Maleate.** Freely soluble in *water*; soluble in *ethanol* (95 per cent) and in *chloroform*; slightly soluble in *ether*.

**Chlorpromazine Hydrochloride.** Very soluble in *water*; freely soluble in *ethanol* (95 per cent); soluble in *chloroform*; practically insoluble in *ether*.

**Chlorpropamide.** Freely soluble in *chloroform* and in *acetone*; soluble in *ethanol* (95 per cent); slightly soluble in *ether*; practically insoluble in *water*. It dissolves in solutions of alkali hydroxides.

**Chlortetracycline Hydrochloride.** Slightly soluble in *water* and in *ethanol* (95 per cent). It dissolves in solutions of alkali hydroxide and carbonates.

**Chorionic Ganadotrophin.** Soluble in *water*; insoluble in *ethanol* (95 per cent), in *acetone* and in *ether*.

**Ciclesonide.** Very soluble in *dichloromethane*; freely soluble in *methanol* and practically insoluble in *water*.

**Cimetidine.** Freely soluble in *methanol*; soluble in *ethanol* (95 per cent); sparingly soluble in *2-propanol*; slightly soluble in *water* and in *chloroform*; practically insoluble in *benzene*, in *dichloromethane* and in *ether*.

**Cinnarizine.** Freely soluble in *dichloromethane*; soluble in *acetone*; slightly soluble in *ethanol* (95 per cent), and in *methanol*; practically insoluble in *water*.

**Ciprofloxacin.** Very slightly soluble in *ethanol* and in *dichloromethane*; practically insoluble in *water*. It dissolves in *dilute acetic acid*.

**Ciprofloxacin Hydrochloride.** Soluble in *water*; slightly soluble in *acetic acid* and in *methanol*; very slightly soluble in *ethanol*; practically insoluble in *acetone*, in *acetonitrile*, in *ethyl acetate*, in *hexane* and in *dichloromethane*.

**Cisplatin.** Sparingly soluble in *dimethylformamide*; slightly soluble in *water*; practically insoluble in *ethanol* (95 per cent).

**Citric Acid.** Very soluble in *water*; freely soluble in *ethanol* (95 per cent); sparingly soluble in *ether*.

**Citric Acid Monohydrate.** Very soluble in *water*; freely soluble in *ethanol* (95 per cent); sparingly soluble in *ether*.

**Clarithromycin.** Practically insoluble in *water*; soluble in *acetone* and *methylne chloride*; slightly soluble in *methanol*.

**Clobazam.** Slightly soluble in *water*; freely soluble in *methylene chloride*; sparingly soluble in *ethanol* (95 per cent).

**Clofazimine.** Soluble in *chloroform*, in *dioxan* and in *dimethylformamide*; slightly soluble in *ethanol* (95 per cent); very slightly soluble in *ether*; insoluble in *water*.

**Clomifene.** Sparingly soluble in *ethanol* (95 per cent); slightly soluble in *water*; practically insoluble in *ether*.

**Clomipramine Hydrochloride.** Freely soluble in *water* and *methylene chloride*; soluble in *ethanol* (95 per cent).

**Clonazepam.** Practically insoluble in *water*; slightly soluble in *ethanol* (95 per cent) and *methanol*.

**Clonidine Hydrochloride.** Freely soluble in *water* and in *ethanol* (95 per cent); slightly soluble in *chloroform*; practically insoluble in *ether*.

**Clotrimazole.** Freely soluble in *acetone*, in *chloroform*, in *ethanol* (95 per cent) and in *methanol*; practically insoluble in *water*.

**Clove Oil.** Freely soluble in *ethanol* (70 per cent).

**Cloxacillin Benzathine.** Freely soluble in *methanol*; soluble in *dichloromethane*; slightly soluble in *water* in *ethanol* (95 per cent) and *2-propanol*.

**Cloxacillin Sodium.** Freely soluble in *water* and in *methanol*; soluble in *ethanol* (95 per cent); slightly soluble in *chloroform*.

**Codeine Phosphate.** Freely soluble in *water*; slightly soluble in *ethanol* (95 per cent); sparingly soluble in *chloroform*; practically insoluble in *ether*.

**Colchicine.** Freely soluble in *water*, but moderately concentrated solutions may deposit crystals of a *sesquihydrate*, which has a limited solubility in cold *water*; freely soluble in *ethanol* (95 per cent) and in *chloroform*; slightly soluble in *ether*.

**Cortisone Acetate.** Soluble in *chloroform* and in *dioxan*; sparingly soluble in *acetone*; slightly soluble in *ethanol* (95 per cent) and in *ether*; practically insoluble in *water*.

**Cresol.** Soluble in *water*, usually forming a cloudy solution. Miscible with *ethanol* (95 per cent), with *chloroform*, with *ether*, with *glycerin* and with fixed and volatile oils.

**Cresol with Soap Solution.** Miscible up to 10 per cent v/v with *water* and in all proportions with *ethanol* (95 per cent).

**Croscarmellose Sodium.** Insoluble in *water*.

**Crospovidone.** Insoluble in *ethanol (95 per cent)*, *ether* and *organic solvents*.

**Cyanocobalamin.** Sparingly soluble in *water* and in *ethanol (95 per cent)*; practically insoluble in *chloroform*, in *acetone* and in *ether*.

**Cyclizine Hydrochloride.** Slightly soluble in *water* and in *ethanol (95 per cent)*; practically insoluble in *ether*.

**Cyclophosphamide.** Freely soluble in *ethanol (95 per cent)*; soluble in *water*; slightly soluble in *ether*.

**Cyclopropane.** Very soluble in *ethanol (95 per cent)*, in *ether* and in *chloroform*. One volume, measured at normal temperature and pressure, dissolves in 2.85 volumes of *water*.

**Cycloserine.** Freely soluble in *water*; very slightly soluble in *ethanol (95 per cent)*; practically insoluble in *chloroform* and in *ether*.

**Cyproheptadine Hydrochloride.** Freely soluble in *methanol*; soluble in *chloroform*; sparingly soluble in *ethanol (95 per cent)*; slightly soluble in *water*; insoluble in *ether*.

**Cytarabine.** Freely soluble in *water*; very slightly soluble in *ethanol (95 per cent)* and in *dichloromethane*.

**Danazol.** Freely soluble in *chloroform*; soluble in *acetone*; sparingly soluble in *ethanol (95 per cent)* and in *benzene*; slightly soluble in *ether*; practically insoluble in *water* and in *hexane*.

**Dapsone.** Freely soluble in *ethanol (95 per cent)* and in *acetone*; very slightly soluble in *water*. It is soluble in dilute mineral acids.

**Dehydroacetic acid.** Freely soluble in *acetone* and in *benzene*; sparingly soluble in *ethanol (95 per cent)*; very slightly soluble in *water*.

**Dehydroemetine Hydrochloride.** Soluble in *water*; slightly soluble in *ethanol (95 per cent)*.

**2-Deoxy-D-Glucose.** Freely soluble in *water*.

**Dequalinium Chloride.** Slightly soluble in *water* and in 1,2-*propanediol*; soluble in boiling *water*.

**Desferrioxamine Mesylate.** Freely soluble in *water*; slightly soluble in *methanol*; very slightly soluble in *ethanol (95 per cent)*; practically insoluble in *chloroform* and in *ether*.

**Deslanoside.** Very slightly soluble in *ethanol (95 per cent)* and in *methanol*; practically insoluble in *water*, in *chloroform* and in *ether*.

**Desoxycortone Acetate.** Freely soluble in *chloroform*; soluble in *acetone*; sparingly soluble in *ethanol (95 per cent)* and in *dioxan*; slightly soluble in 1,2-*propanediol*; practically insoluble in *water*.

**Dexamethasone.** Sparingly soluble in *ethanol (95 per cent)*, in *acetone* and in *methanol*; slightly soluble in *chloroform*; very slightly soluble in *ether*; practically insoluble in *water*.

**Dexamethasone Sodium Phosphate.** Freely soluble in *water*; slightly soluble in *ethanol (95 per cent)*; very slightly soluble in *dioxan*; practically insoluble in *chloroform* and in *ether*.

**Dextrin.** Very soluble in boiling *water* forming a mucilaginous solution; slowly soluble in cold *water*; practically insoluble in *ethanol (95 per cent)* and in *ether*.

**Dextromethorphan Hydrobromide.** Freely soluble in *ethanol (95 per cent)* and in *chloroform*; sparingly soluble in *water*; practically insoluble in *ether*.

**Dextrose.** Freely soluble in *water*; sparingly soluble in *ethanol (95 per cent)*.

**Diazepam.** Freely soluble in *chloroform*; soluble in *ethanol (95 per cent)*; very slightly soluble in *water*.

**Dibasic Calcium Phosphate.** Practically insoluble in *water* and in *ethanol (95 per cent)*. It dissolves in *dilute hydrochloric acid* and in *nitric acid*.

**Dibutyl Phthalate.** Miscible with *ethanol (95 per cent)* and with *ether*; practically insoluble in *water*.

**Dichlofenthion.** Miscible with *ethanol (95 per cent)* and with *dichloromethane*; immiscible with *water*.

**Diclofenac Sodium.** Freely soluble in *methanol*; soluble in *ethanol (95 per cent)*; sparingly soluble in *water* and in *glacial acetic acid*; practically insoluble in *ether*, in *chloroform* and in *toluene*.

**Dichlorophen.** Very soluble in *ether*; freely soluble in *ethanol (95 per cent)*; practically insoluble in *water*.

**Dicyclomine Hydrochloride.** Freely soluble in *ethanol (95 per cent)* and in *chloroform*; soluble in *water*; practically insoluble in *ether*.

**Didanosine.** Soluble in *water*.

**Dienoestrol.** Freely soluble in *ethanol (95 per cent)* and in *acetone*; soluble in *ether*; slightly soluble in *chloroform*; practically insoluble in *water*. It is soluble in dilute solutions of alkali hydroxides.

**Diethylcarbamazine Citrate.** Very soluble in *water*; soluble in *ethanol (95 per cent)*; practically insoluble in *acetone*, in *chloroform* and in *ether*.

**Diethyl Phenyl Acetamide.** Practically insoluble in *water*; soluble in *ethanol (95 per cent)*, *isopropyl alcohol* and *ether*.

**Diethyl Phthalate.** Insoluble in *water*; miscible with *ethanol (95 per cent)* and *ether*.

**Diethyltoluamide.** Miscible with *ethanol (95 per cent)*, with *chloroform*, with *ether* and with 2-*propanol*; practically insoluble in *water* and in *glycerin*.

**Digitoxin.** Freely soluble in a mixture of equal volumes of *chloroform* and *methanol*; sparingly soluble in *chloroform*;



slightly soluble in *ethanol* (95 per cent), in *methanol* and in *ether*; practically insoluble in *water*.

**Digoxin.** Freely soluble in *pyridine* and in a mixture of equal volumes of *dichloromethane* and *methanol*; slightly soluble in *ethanol* (95 per cent); practically insoluble in *water*.

**Diiodohydroxyquinoline.** Sparingly soluble in *ethanol* (95 per cent) and in *ether*; practically insoluble in *water*.

**Diloxanide Furoate.** Freely soluble in *chloroform*; slightly soluble in *ethanol* (95 per cent) and in *ether*; very slightly soluble in *water*.

**Diltiazem Hydrochloride.** Freely soluble in *chloroform*, in *methanol*, in *water* and in *formic acid*; sparingly soluble in *ethanol*; insoluble in *ether*.

**Dimercaprol.** Soluble in *water*, in *ethanol* (95 per cent), in *methanol* and in *benzyl benzoate*. Dissolves in *arachis oil*.

**Dimethicone Activated.** Miscible with *carbon tetrachloride*, with *chloroform*, with *ether*, with *ethyl acetate*, with *methyl ethyl ketone* and with *toluene*; very slightly soluble in *ethanol*, but silicon dioxide remains as a residue in the solvents; practically insoluble in *water* and in *methanol*.

**Dihydrostreptomycin Sulphate.** Freely soluble in *water*; practically insoluble in *dichloromethane*, in *methylene*, in *ethanol* (95 per cent) and in *acetone*.

**Dimetridazole.** Freely soluble in *dichloromethane*; sparingly soluble in *ethanol* (95 per cent); slightly soluble in *water* and in *ether*.

**Dinitolmide.** Soluble in *acetone*; slightly soluble in *dichloromethane*, in *ether* and in *ethanol* (95 per cent); practically insoluble in *water*.

**Diphenhydramine Hydrochloride.** Very soluble in *water*; freely soluble in *chloroform* and in *ethanol* (95 per cent); practically insoluble in *ether*.

**Diphenoxylate Hydrochloride.** Freely soluble in *dichloromethane*; sparingly soluble in *ethanol* (95 per cent); very slightly soluble in *water*; practically insoluble in *ether*.

**Disodium Edetate.** Soluble in *water*; sparingly soluble in *ethanol* (95 per cent); practically insoluble in *chloroform* and in *ether*.

**Disulfiram.** Freely soluble in *dichloromethane*; soluble in *ether*, in *acetone*, in *carbon disulphide* and in *chloroform*; sparingly soluble in *ethanol* (95 per cent); practically insoluble in *water*.

**Dithranol.** Soluble in *chloroform* and in fixed oils; slightly soluble in *ethanol* (95 per cent) and in *ether*; practically insoluble in *water*.

**Docusate Sodium.** Soluble in *carbon tetrachloride*, *xylene*, *acetone*, *ethanol* (95 per cent); very slightly soluble in *water*.

**Domperidone Maleate.** Very soluble in *water*; sparingly soluble in *dimethylformamide*; slightly soluble in *methanol* and *ethanol* (95 per cent).

**Donepezil Hydrochloride.** Freely soluble in *chloroform*; soluble in *water* and *glacial acetic acid*; slightly soluble in *ethanol* (95 per cent) and in *acetonitrile*; practically insoluble in *ethyl acetate* and in *n-hexane*.

**Dothiepin Hydrochloride.** Freely soluble in *water*, in *chloroform* and in *ethanol* (95 per cent); practically insoluble in *ether*.

**Doxepin Hydrochloride.** Freely soluble in *water*, in *ethanol* (95 per cent) and in *chloroform*.

**Doxorubicin Hydrochloride.** Soluble in *water*; slightly soluble in *methanol*; practically insoluble in *chloroform*, in *ether* and in other organic solvents.

**Doxycycline Hydrochloride.** Freely soluble in *water* and in *methanol*; sparingly soluble in *ethanol* (95 per cent); practically insoluble in *chloroform* and in *ether*. It is soluble in solutions of alkali hydroxides and carbonates.

**Dydrogesterone.** Freely soluble in *chloroform*; soluble in *acetone*; sparingly soluble in *ethanol* (95 per cent) and in *methanol*; slightly soluble in *ether*; practically insoluble in *water*.

**Econazole Nitrate.** Soluble in *methanol*; sparingly soluble in *dichloromethane*; slightly soluble in *ethanol* (95 per cent); very slightly soluble in *water*; practically insoluble in *ether*.

**Efavirenz.** Freely soluble in *methanol* and in *dichloromethane*.

**Emetine Hydrochloride.** Freely soluble in *water* and in *ethanol* (95 per cent).

**Emtricitabine.** Soluble in *water*; sparingly soluble in *methanol*.

**Emulsifying Wax.** Partly soluble in *ethanol* (95 per cent); practically insoluble in *water*, forming an emulsion.

**Enalapril Maleate.** Freely soluble in *methanol* and in *dimethylformamide*; soluble in *ethanol* (95 per cent); sparingly soluble in *water*; slightly soluble in semipolar organic solvents; practically insoluble in nonpolar organic solvents.

**Ephedrine.** Very soluble in *ethanol* (95 per cent); freely soluble in *ether*; soluble in *water* and in *chloroform*. Solutions of the hemihydrate in *chloroform* may show separation of water.

**Ephedrine Hydrochloride.** Freely soluble in *water*; soluble in *ethanol* (95 per cent); practically insoluble in *ether*.

**Ergocalciferol.** Freely soluble in *ethanol* (95 per cent), in *chloroform* and in *ether*; practically insoluble in *water*. It is soluble in fixed oils. Solutions in volatile solvents are unstable and should be used immediately.

**Ergometrine Maleate.** Soluble in *water*; slightly soluble in *ethanol* (95 per cent); practically insoluble in *chloroform* and in *ether*.

**Ergotamine Tartrate.** Slightly soluble in *ethanol* (95 per cent) and in *chloroform*; practically insoluble in *ether*. It dissolves in *water* but the solution may become hazy which may be prevented by the addition of tartaric acid.

**Erythromycin.** Freely soluble in *ethanol* (95 per cent); soluble in *chloroform* and in *methanol*; slightly soluble in *water*. It dissolves in 2M hydrochloric acid.

**Erythromycin Estolate.** Freely soluble in *chloroform*; soluble in *ethanol* (95 per cent) and in *acetone*; practically insoluble in *water* and in 2M hydrochloric acid.

**Erythromycin Stearate.** Soluble in *ethanol*, in *methanol*, in *acetone* and in *chloroform* (solutions in these solvents may be opalescent); practically insoluble in *water*.

**Ethacrynic Acid.** Freely soluble in *ethanol* (95 per cent), in *chloroform* and in *ether*; very slightly soluble in *water*. It dissolves in ammonia and dilute aqueous solutions of alkali hydroxides and carbonates.

**Ethambutol Hydrochloride.** Freely soluble in *water*; soluble in *ethanol* (95 per cent); slightly soluble in *chloroform*; very slightly soluble in *ether*.

**Ethanol.** Miscible with *water*, with *chloroform*, with *ether* and with *glycerin*.

**Ethanol (95 per cent).** Miscible in all proportions with *water*, with *chloroform*, with *ether* and with *glycerin*.

**Ether Anaesthetic.** Soluble in *water*; miscible with *ethanol* (95 per cent), with *chloroform*, with *benzene* and with fixed and volatile oils.

**Ethinylestradiol.** Freely soluble in *ethanol* (95 per cent) and in *ether*; sparingly soluble in *chloroform*; practically insoluble in *water*. It dissolves in dilute solutions of alkalis.

**Ethionamide.** Soluble in *methanol*; sparingly soluble in *ethanol* (95 per cent); slightly soluble in *chloroform* and in *ether*; practically insoluble in *water*.

**Ethopabate.** Soluble in *dichloromethane* and in *methanol*; sparingly soluble in *ethanol* (95 per cent); slightly soluble in *ether*; very slightly soluble in *water*.

**Ethopropazine Hydrochloride.** Freely soluble in *chloroform* and in *ethanol* (95 per cent); sparingly soluble in *acetone*; slightly soluble in *water*; practically insoluble in *ether*.

**Ethyl Chloride.** Slightly soluble in *water*; miscible with *ethanol* (95 per cent) and with *ether*.

**Ethyl Oleate.** Practically insoluble in *water*; miscible with *ethanol* (95 per cent), with *chloroform*, with *ether* and with fixed oils.

**Ethylenediamine Hydrate.** Slightly soluble in *chloroform* and in *ether*; miscible with *water* and with *ethanol* (95 per cent).

**Ethylestrenol.** Freely soluble in *ethanol* (95 per cent), in *chloroform* and in *ether*; practically insoluble in *water*.

**Etoposide.** Practically insoluble in *water*; sparingly soluble in *methanol*, slightly soluble in *ethanol* (95 per cent) and in *methylene chloride*.

**Eucalyptus Oil.** Miscible with *ethanol*, *chloroform*, *ether*, *glacial acetic acid* and oils. Practically insoluble in *water*.

**Ferrous Fumarate.** Slightly soluble in *water*; very slightly soluble in *ethanol* (95 per cent).

**Ferrous Gluconate.** Freely but slowly soluble in *water*; more readily soluble on warming; practically insoluble in *ethanol* (95 per cent).

**Ferrous Sulphate.** Very soluble in boiling *water*; freely soluble in *water*; practically insoluble in *ethanol* (95 per cent).

**Ferrous Sulphate Dried.** Dissolves slowly, but almost completely, in freshly boiled and cooled *water*.

**Fludrocortisone Acetate.** Sparingly soluble in *ethanol* (95 per cent) and in *chloroform*; slightly soluble in *ether*; practically insoluble in *water*.

**Fluocinolone Acetonide.** Soluble in *acetone*, in *ethanol* and in *chloroform*; practically insoluble in *water* and in *light petroleum*.

**Fluorescein Sodium.** Freely soluble in *water*; sparingly soluble in *ethanol* (95 per cent).

**Fluorouracil.** Sparingly soluble in *water*; slightly soluble in *ethanol* (95 per cent); practically insoluble in *chloroform* and in *ether*.

**Fluphenazine Decanoate.** Miscible with *ethanol*, with *chloroform* and with *ether*; practically insoluble in *water*. It dissolves in fixed oils.

**Fluphenazine Hydrochloride.** Freely soluble in *water*; sparingly soluble in *ethanol* (95 per cent) and in *dichloromethane*; practically insoluble in *ether*.

**Fluticasone propionate.** Practically insoluble in *water*; sparingly soluble in *methylene chloride* and slightly soluble in *ethanol* (95 per cent).

**Flurbiprofen.** Freely soluble in *ethanol* (95 per cent), in *chloroform* and in *ether*; practically insoluble in *water*. It dissolves in aqueous solutions of alkali hydroxides and carbonates.

**Folic Acid.** Practically insoluble in cold *water* and in most organic solvents; very slightly soluble in boiling *water*; soluble in dilute acids and in alkaline solutions.

**Formoterol Fumarate Dihydrate.** Slightly soluble in *water*; soluble in *m ethanol*; practically insoluble in *acetonitrile*.



**Framycetin Sulphate.** Freely soluble in *water*; very slightly soluble in *ethanol* (95 per cent); practically insoluble in *acetone*, in *chloroform* and in *ether*.

**d- Fructose.** Very soluble in *water*; soluble in *ethanol* (95 per cent).

**Frusemide.** Soluble in *acetone*; sparingly soluble in *ethanol* (95 per cent); practically insoluble in *water*. It dissolves in dilute aqueous solutions of alkali hydroxides.

**Furazolidone.** Slightly soluble in *chloroform*; very slightly soluble in *water* and in *ethanol* (95 per cent); practically insoluble in *ether*.

**Fusidic Acid.** Freely soluble in *ethanol* (95 per cent) and in *chloroform*; sparingly soluble in *ether*; practically insoluble in *water*.

**Gallamine Triethiodide.** Very soluble in *water*; slightly soluble in *ethanol* (95 per cent); very slightly soluble in *chloroform*; practically insoluble in *ether*.

**Gatifloxacin.** Very slightly soluble in *water*; *methanol* and *chloroform*.

**Gelatin.** Practically insoluble in *water* but swells and softens when immersed in it, gradually absorbing from 5 to 10 times its own weight; soluble in hot *water*; practically insoluble in most organic solvents.

**Gentamicin Sulphate.** Freely soluble in *water*; practically insoluble in *chloroform*, in *ethanol* (95 per cent) and in *ether*.

**Glibenclamide.** Sparingly soluble in *dichloromethane*; slightly soluble in *ethanol* (95 per cent) and in *methanol*; practically insoluble in *water* and in *ether*. It dissolves in dilute solutions of alkali hydroxides.

**Glipizide.** Practically insoluble in *water*; very slightly soluble in *methylene chloride* and *acetone*; practically insoluble in *ethanol* (95 per cent).

**Glycerin.** Miscible with *water* and with *ethanol* (95 per cent); slightly soluble in *acetone*; practically insoluble in *ether* and in fixed oils and volatile oils.

**Glyceryl Monostearate.** Freely soluble in *chloroform*; soluble in *ether*, in *benzene* and in *ethanol* (95 per cent); practically insoluble in *water*.

**Glyceryl Trinitrate Solution, Concentrated.** Miscible with *acetone* and with *ether*.

**Glycine.** Freely soluble in *water*; very slightly soluble in *ethanol* (95 per cent); practically insoluble in *ether*.

**Griseofulvin.** Freely soluble in *dimethylformamide* and in *1,1,2,2-tetrachloroethane*; soluble in *acetone* and in *chloroform*; slightly soluble in *ethanol* (95 per cent) and in *methanol*; practically insoluble in *water*.

**Guaiphenesin.** Soluble in *ethanol* (95 per cent) and in *chloroform*; sparingly soluble in *water*; slightly soluble in *ether*.

**Guar Gum.** When stirred with 50 parts of *water*, a thick jelly is formed which, with further addition of 150 parts of *water*, yields a thick transparent suspension; practically insoluble in *ethanol* (95 per cent).

**Guggul Resin.** Sparingly soluble in *ethanol* (95 per cent), in *methanol* and in *chloroform*; practically insoluble in *water*.

**Gugulipid.** Soluble in *ethanol* (95 per cent), in *methanol*, in *ethyl acetate*, and in *chloroform*; insoluble in *water*.

**Haloperidol.** Soluble in *chloroform*; sparingly soluble in *ethanol* (95 per cent) and in *dichloromethane*; slightly soluble in *ether*; practically insoluble in *water*.

**Haloxon.** Freely soluble in *ethanol* (95 per cent), in *dichloromethane* and in *acetone*; practically insoluble in *water*.

**Heparin Sodium.** Soluble in *water* and in *saline solution* forming a clear, colourless or straw-coloured liquid.

**Histamine Phosphate.** Freely soluble in *water*; slightly soluble in *ethanol* (95 per cent).

**Homatropine Hydrobromide.** Freely soluble in *water*; sparingly soluble in *ethanol* (95 per cent); very slightly soluble in *ether*.

**Hyaluronidase.** Very soluble in *water*; practically insoluble in *ethanol* (95 per cent), in *acetone* and in *ether*.

**Hydralazine Hydrochloride.** Soluble in *water*; slightly soluble in *ethanol* (95 per cent) and in *methanol*; practically insoluble in *chloroform*, in *dichloromethane* and in *ether*.

**Hydrochloric Acid.** Miscible with *water*.

**Hydrochlorothiazide.** Soluble in *acetone*; sparingly soluble in *ethanol* (95 per cent); very slightly soluble in *water*. It dissolves in dilute solutions of alkali hydroxides.

**Hydrocortisone.** Sparingly soluble in *ethanol* (95 per cent) and in *acetone*; slightly soluble in *chloroform*; very slightly soluble in *ether*; practically insoluble in *water*.

**Hydrocortisone Acetate.** Slightly soluble in *ethanol* (95 per cent) and in *chloroform*; practically insoluble in *water*.

**Hydrocortisone Hemisuccinate.** Freely soluble in *acetone* and in *ethanol* (95 per cent); practically insoluble in *ether* and in *water*. It dissolves in solutions of alkali carbonates and alkali hydroxides.

**Hydrogenated Castor Oil.** Soluble in *acetone*, in *chloroform* and in *carbon tetrachloride*; insoluble in *water*.

**Hydroxocobalamin.** Soluble in *water*.

**Hydroxyprogesterone Hexanoate.** Very soluble in *chloroform*; freely soluble in *ethanol* (95 per cent) and in *ether*; practically insoluble in *water*. It dissolves in fixed oils and esters.

**Hydroxypropylcellulose.** Soluble in cold *water*, in *ethanol*, in *methanol* and in *propylene glycol* forming colloidal solutions; slightly soluble in *acetone*; very slightly soluble in *toluene*; practically insoluble in hot *water*.

**Hydroxypropylmethylcellulose.** Practically insoluble in hot *water*, in *acetone*, in *ethanol*, in *ether* and in *toluene*. It swells in *water* forming an opalescent, viscous colloidal solution.

**Hyoscine Butylbromide.** Freely soluble in *water* and in *chloroform*; sparingly soluble in *ethanol*.

**Hyoscine Hydrobromide.** Freely soluble in *water*; soluble in *ethanol* (95 per cent); practically insoluble in *chloroform* and in *ether*.

**Ibuprofen.** Freely soluble in *acetone*, in *chloroform*, in *ethanol* (95 per cent) and in *ether*; practically insoluble in *water*. It dissolves in dilute solutions of alkali hydroxides and carbonates.

**Idoxuridine.** Slightly soluble in *water* and in *ethanol* (95 per cent); practically insoluble in *ether*. It dissolves in dilute solutions of alkali hydroxides.

**Imipenem.** Sparingly soluble in *water*; slightly soluble in *methanol*.

**Imipramine Hydrochloride.** Freely soluble in *water*, in *ethanol* (95 per cent) and in *chloroform*; practically insoluble in *ether*.

**Indinavir Sulphate.** Freely soluble in *water*; soluble in *methanol*.

**Indomethacin.** Soluble in *chloroform*; sparingly soluble in *ethanol* (95 per cent) and in *ether*; practically insoluble in *water*.

**Insulin.** Practically insoluble in *water* and in *ethanol* (95 per cent) and in *ether*. It dissolves in dilute mineral acids and, with decomposition, in dilute solutions of alkali hydroxides.

**Insulin, Human.** Practically insoluble in *water* and in *ethanol* (95 per cent) and in *ether*. It dissolves in dilute mineral acids and, with decomposition, in dilute solutions of alkali hydroxides.

**Iodine.** Soluble in *chloroform* and in *ethanol* (95 per cent); slightly soluble in *glycerin*; very slightly soluble in *water*. Very soluble in concentrated solutions of iodides.

**Ipratropium Bromide.** Soluble in *water*; freely soluble in *methanol*; slightly soluble in *ethanol* (95 per cent).

**Irinotecan Hydrochloride Trihydrate.** Soluble in *water*.

**Iron and Ammonium Citrate.** Very soluble in *water*; practically insoluble in *ethanol* (95 per cent).

**Isoniazid.** Freely soluble in *water*; sparingly soluble in *ethanol* (95 per cent); slightly soluble in *chloroform*; very slightly soluble in *ether*.

**Isoprenaline Hydrochloride.** Freely soluble in *water*; sparingly soluble in *ethanol* (95 per cent); insoluble in *chloroform* and in *ether*.

**Isoprenaline Sulphate.** Freely soluble in *water*; practically insoluble in *ethanol* (95 per cent), in *chloroform* and in *ether*.

**Isopropyl Alcohol.** Miscible with *water*, with *chloroform* and with *ether*.

**Isosorbide Dinitrate, Diluted.** Undiluted isosorbide dinitrate is very soluble in *acetone*; freely soluble in *chloroform*; sparingly soluble in *ethanol* (95 per cent); very slightly soluble in *water*.

**Isoxsuprine Hydrochloride.** Slightly soluble in *water*; sparingly soluble in *ethanol* (95 per cent); practically insoluble in *chloroform* and in *ether*.

**Ivermectin.** Highly soluble in *methyl ethyl ketone*, in *propylene glycol* and in *polyethyleneglycol*; insoluble in *cyclohexane*.

**Kanamycin Acid Sulphate.** Freely soluble in *water*; practically insoluble in *ethanol* (95 per cent), in *acetone*, in *chloroform* and in *ether*.

**Kanamycin Sulphate.** Freely soluble in *water*; practically insoluble in *acetone*, in *chloroform*, in *ether* and in *ethanol* (95 per cent).

**Heavy Kaolin.** Practically insoluble in *water* and in organic solvents. It does not dissolve in mineral acids and in solutions of alkali hydroxides.

**Ketamine Hydrochloride.** Freely soluble in *water* and in *methanol*; soluble in *ethanol* (95 per cent); sparingly soluble in *chloroform*; practically insoluble in *ether* and in *benzene*.

**Ketoconazole.** Freely soluble in *dichloromethane*; soluble in *chloroform* and in *methanol*; sparingly soluble in *ethanol* (95 per cent); practically insoluble in *water* and in *ether*.

**Ketoprofen.** Freely soluble in *ethanol* (95 per cent), in *chloroform* and in *ether*; practically insoluble in *water*.

**Labetalol Hydrochloride.** Sparingly soluble in *water* and in *ethanol* (95 per cent); practically insoluble in *chloroform* and in *ether*.

**Lactic acid.** Miscible in all proportions with *water*, with *ethanol* (95 per cent) and with *ether*.

**Lactose.** Freely but slowly soluble in *water*; practically insoluble in *ethanol* (95 per cent).

**Lamivudine.** Soluble in *water*; sparingly soluble in *methanol*.

**Lamotrigine.** Soluble in *methanol* and *chloroform*; slightly soluble in *water*.

**Lanatoside C.** Soluble in *methanol*; practically insoluble in *water*, in *chloroform* and in *ether*.

**Levamisole Hydrochloride.** Freely soluble in *water*; soluble in *ethanol* (95 per cent); slightly soluble in *dichloromethane*; practically insoluble in *ether*.

**Levodopa.** Slightly soluble in *water*; practically insoluble in *chloroform*, in *ethanol* (95 per cent) and in *ether*. Freely soluble in 1M hydrochloric acid but sparingly soluble in 0.1M hydrochloric acid.

**Levofloxacin Hemihydrate.** Slightly soluble in *methanol*; sparingly soluble in *acetic acid* and *chloroform*; soluble in dilute sodium hydroxide solution.

**Levonorgestrel.** Sparingly soluble in *chloroform* and in *dichloromethane*; slightly soluble in *acetone*, in *ethanol* (95 per cent) and in *ether*; practically insoluble in *water*.

**Lignocaine Hydrochloride.** Very soluble in *water*; freely soluble in *chloroform* and in *ethanol* (95 per cent); practically insoluble in *ether*.

**Lincromycin Hydrochloride.** Freely soluble in *water*; soluble in *dimethylformamide*; slightly soluble in *ethanol* (95 per cent); very slightly soluble in *acetone*; practically insoluble in *chloroform* and in *ether*.

**Lindane.** Freely soluble in *acetone* and in *ether*; soluble in *ethanol* (95 per cent); practically insoluble in *water*.

**Lisinopril.** Soluble in *water*; very slightly soluble in *ethanol* (95 per cent).

**Lithium Antimony Thiomalate.** Soluble in *water*; slightly soluble in *ethanol* (95 per cent) and in *ether*.

**Lithium Carbonate.** Slightly soluble in *water*; practically insoluble in *ethanol* (95 per cent).

**Lomustine.** Freely soluble in *acetone*, in *chloroform* and in *dichloromethane*; soluble in *ethanol* (95 per cent); practically insoluble in *water*.

**Loperamide Hydrochloride.** Freely soluble in *methanol*; soluble in *ethanol* (95 per cent); slightly soluble in *water*.

**Lopinavir.** Freely soluble in *methanol* and in *dichloromethane*; practically insoluble in *water*.

**Losartan Potassium.** Freely soluble in *water*; soluble in *isopropyl alcohol*; slightly soluble in *acetonitrile*.

**Lynoestrenol.** Freely soluble in *chloroform*; soluble in *ethanol* (95 per cent), in *acetone*, and in *ether*; practically insoluble in *water*.

**Magaldrate.** Insoluble in *water* and in *ethanol* (95 per cent). Soluble in dilute solutions of mineral acids.

**Heavy Magnesium Carbonate.** Practically insoluble *water*. It dissolves in dilute acids with strong effervescence.

**Light Magnesium Carbonate.** Practically insoluble in *water*. It dissolves in dilute acids with strong effervescence.

**Magnesium Chloride.** Very soluble in *water*; freely soluble in *ethanol* (95 per cent).

**Magnesium hydroxide.** Practically insoluble in *water* and in *ethanol* (95 per cent). It dissolves in dilute acids.

**Magnesium Hypophosphite.** Very soluble in boiling *water*; freely soluble in *water*; practically insoluble in *ethanol* (95 per cent).

**Heavy Magnesium Oxide.** Practically insoluble in *water*; insoluble in *ethanol* (95 per cent). It dissolves in dilute acids with at most slight effervescence.

**Light Magnesium Oxide.** Practically insoluble in *water*; insoluble in *ethanol* (95 per cent). It dissolves in dilute acids with at most slight effervescence.

**Magnesium Stearate.** Practically insoluble in *water*; in *ethanol* and in *ether*.

**Magnesium Sulphate.** Very soluble in boiling *water*; freely soluble in *water*; practically insoluble in *ethanol* (95 per cent).

**Magnesium Trisilicate.** Practically insoluble in *water* and in *ethanol* (95 per cent).

**Malt Extract.** Almost completely soluble in cold *water*, more readily in warm *water*. An aqueous solution is not clear and deposits a voluminous precipitate on standing.

**Mannitol.** Freely soluble in *water*; slightly soluble in *pyridine*; very slightly soluble in *ethanol* (95 per cent); insoluble in *chloroform* and in *ether*.

**Mebendazole.** Freely soluble in *formic acid*; practically insoluble in *water*, in *dichloromethane*, in *ethanol* (95 per cent) and in *ether*.

**Mebeverine Hydrochloride.** Very soluble in *water*; freely soluble in *ethanol* (95 per cent); practically insoluble in *ether*.

**Meclofenamic Acid.** Soluble in *dimethylformamide* and in 1M sodium hydroxide; slightly soluble in *ethanol* (95 per cent) and in *dichloromethane* sparingly soluble in *ether*; practically insoluble in *water*.

**Meclizine Hydrochloride.** Soluble in *dichloromethane*, in *chloroform* and in *ethanol* (95 per cent); slightly soluble in *water*; practically insoluble in *ether*.

**Medroxyprogesterone Acetate.** Freely soluble in *chloroform*; soluble in *acetone* and in *dioxan*; sparingly soluble in *ethanol* (95 per cent) and in *methanol*; slightly soluble in *ether* and insoluble in *water*.

**Mefenamic Acid.** Sparingly soluble in *ether*; slightly soluble in *ethanol* (95 per cent) and in *chloroform*; practically insoluble in *water*.

**Megestrol Acetate.** Very soluble in *chloroform*; sparingly soluble in *ethanol* (95 per cent); slightly soluble in *ether* and in fixed oils; practically insoluble in *water*.

**Melphalan.** Slightly soluble in *methanol* and in *ethanol* (95 per cent); practically insoluble in *water*, in *chloroform* and in *ether*. It dissolves in dilute mineral acids.



**Menadione.** Freely soluble in *chloroform* and in *toluene*; soluble in *ether*; sparingly soluble in *ethanol* (95 per cent) and in *methanol*; practically insoluble in *water*.

**Mentha oil.** 1 ml dissolves in 3.5 to 4 ml of *ethanol* (70 per cent); on further addition of 5 to 10 ml of *ethanol* (70 per cent), the solution remains clear or is not more than slightly opalescent.

**Menthol.** Very soluble in *ethanol* (95 per cent) and in *ether*; freely soluble in *light liquid paraffin*, in *glacial acetic acid* and in volatile oils; slightly soluble in *water*.

**Mephentermine Sulphate.** Soluble in *water*; slightly soluble in *ethanol* (95 per cent).

**Mepyramine Maleate.** Very soluble in *water*; freely soluble in *chloroform* and in *ethanol* (95 per cent); very slightly soluble in *ether*.

**Mercaptopurine.** Slightly soluble in *ethanol* (95 per cent); practically insoluble in *water* and in *ether*. It dissolves in solutions of alkali hydroxides.

**Meropenem.** Soluble in *dimethylformamide* and in 5 per cent w/v solution of *monobasic potassium phosphate*; sparingly soluble in *water*; very slightly soluble in *ethanol* (95 per cent); practically insoluble in *acetone* and in *ether*.

**Mestranol.** Freely soluble in *chloroform*; soluble in *ether*; slightly soluble in *methanol*; sparingly soluble in *ethanol* (95 per cent); practically insoluble in *water*.

**Metformin Hydrochloride.** Freely soluble in *water*; slightly soluble in *ethanol* (95 per cent); practically insoluble in *acetone*, in *chloroform*, in *dichloromethane* and in *ether*.

**Methadone Hydrochloride.** Freely soluble in *ethanol* (95 per cent) and in *chloroform*; soluble in *water*; practically insoluble in *ether*.

**Methdilazine Hydrochloride.** Freely soluble in *water*, in *ethanol* (95 per cent) and in *chloroform*.

**Methotrexate.** Practically insoluble in *water*, *1,2-dichloroethane*, in *ethanol* (95 per cent) and in *ether*. It dissolves in dilute solutions of mineral acids and in dilute solutions of alkali hydroxides and in carbonates.

**Methoxamine Hydrochloride.** Freely soluble in *water*; soluble in *ethanol* (95 per cent); very slightly soluble in *chloroform* and in *ether*.

**Methyl Salicylate.** Miscible with *chloroform*, with *ethanol* (95 per cent) and with fixed and volatile oils; very slightly soluble in *water*.

**Methylcellulose.** Practically insoluble in hot *water*; in *acetone*, in *ethanol*, in *ether* and in *toluene*. It dissolves in cold *water* forming a colloidal solution.

**Methyldopa.** Slightly soluble in *water*; very slightly soluble in *ethanol* (95 per cent); practically insoluble in *chloroform* and in *ether*. It is freely soluble in *dilute hydrochloride acid*.

**Methylergometrine Maleate.** Soluble in *ethanol* (95 per cent); slightly soluble in *water*; very slightly soluble in *chloroform* and in *ether*.

**Methylparaben.** Freely soluble in *ethanol* (95 per cent), in *ether* and in *methanol*; very slightly soluble in *water*.

**Methyl prednisolone.** Sparingly soluble in *ethanol*; slightly soluble in *acetone* and in *chloroform*; very slightly soluble in *ether*; practically insoluble in *water*.

**Methylprednisolone Acetate.** Slightly soluble in *ethanol*; very slightly soluble in *ether*; practically insoluble in *water*.

**Metochlopramide Hydrochloride.** Very soluble in *water*; freely soluble in *ethanol* (95 per cent); sparingly soluble in *dichloromethane*; practically insoluble in *ether*.

**Metoprolol Tartrate.** Very soluble in *water*; freely soluble in *ethanol* (95 per cent), in *chloroform* and in *dichloromethane*; slightly soluble in *acetone*; practically insoluble in *ether*.

**Metronidazole.** Slightly soluble in *water*, in *ethanol* (95 per cent), in *acetone* and in *dichloromethane*; very slightly soluble in *ether*.

**Metronidazole Benzoate.** Freely soluble in *chloroform*, in *dichloromethane* and in *ethanol* (59 per cent); soluble in *acetone*; slightly soluble in *ether*; practically insoluble in *water*.

**Mexiletine Hydrochloride.** Freely soluble in *water* and in *methanol*; sparingly soluble in *dichloromethane*; practically insoluble in *ether*.

**Mianserin Hydrochloride.** Soluble in *chloroform* and in *dichloromethane*; sparingly soluble in *water*; slightly soluble in *ethanol* (95 per cent).

**Miconazole Nitrate.** Freely soluble in *methanol*; slightly soluble in *ethanol* (95 per cent) and in *chloroform*; very slightly soluble in *water* and in *ether*.

**Mirocrystalline Cellulose.** Insoluble in *water* but swells producing a white opaque dispersion or gel; slightly soluble in *dilute sodium hydroxide* solution. It is insoluble in dilute acids and in most organic solvents.

**Microcrystalline Wax.** Soluble in *chloroform*, in *ether*, in volatile oils and in most warm fixed oils; sparingly soluble in *ethanol*; practically insoluble in *water*.

**Minoxidil.** Soluble in *methanol* and in *propylene glycol*; slightly soluble in *water*; very slightly soluble in *ether*; practically insoluble in *chloroform* and in *acetone*.

**Monosulfiram.** Practically insoluble in *water*, in *acids* and in alkalis. Freely soluble in organic solvents

**Monothioglycerol.** Freely soluble in *water*; miscible with *ethanol* (95 per cent); practically insoluble in *ether*.

**Morphine Sulphate.** Soluble in *water*; freely soluble in hot *water*; slightly soluble in *ethanol* (95 per cent) but more soluble in hot *ethanol* (95 per cent); practically insoluble in *chloroform* and in *ether*.

**Mustine Hydrochloride.** Very soluble in *water*.

**Nalidixic Acid.** Soluble in *dichloromethane*; slightly soluble in *acetone* and in *ethanol* (95 per cent); very slightly soluble in *ether*; practically insoluble in *water*. It dissolves in dilute solutions of alkali hydroxides.

**Nalorphine Hydrochloride.** Freely soluble in *water*; sparingly soluble in *ethanol* (95 per cent); practically insoluble in *chloroform* and in *ether*. It dissolves in dilute solution of alkali hydroxides.

**Nandrolone Decanoate.** Freely soluble in *chloroform*, in *ethanol* (95 per cent), in *methanol*, in *ether*, in fixed oils and in esters; practically insoluble in *water*.

**Nandrolone Laurate.** Freely soluble in *ethanol* (95 per cent), in *dichloromethane* and in *ether*; practically insoluble in *water*. Freely soluble in fixed oils and esters of fatty acids.

**Nandrolone Phenylpropionate.** Soluble in *ethanol* (95 per cent); practically insoluble in *water*.

**Naphazoline Nitrate.** Soluble in *ethanol* (95 per cent); sparingly soluble in *water*; very slightly soluble in *chloroform*; practically insoluble in *ether*.

**Nelfinavir Mesylate.** Soluble in *methanol*.

**Neomycin Sulphate.** Freely soluble in *water*; in slightly soluble in *ethanol* (95 per cent); practically insoluble in *acetone*, in *chloroform* and in *ether*.

**Neostigmine Bromide.** Very soluble in *water*; freely soluble in *ethanol* (95 per cent); and in *chloroform*; practically insoluble in *ether*.

**Neostigmine Methylsulphate.** Very soluble in *water*, freely soluble in *ethanol* (95 per cent) and in *chloroform*; practically insoluble in *ether*.

**Nevirapine.** Soluble in *dichloromethane*, in *dimethylsulphoxide* and in *dimethylformamide*.

**Niclosamide.** Sparingly soluble in *acetone*; slightly soluble in *ethanol*; practically insoluble in *water*.

**Nicotinamide.** Freely soluble in *water* and in *ethanol* (95 per cent); slightly soluble in *chloroform* and in *ether*.

**Nicotinic Acid.** Soluble in boiling *water* and in boiling *ethanol* (95 per cent); sparingly soluble in *water*; very slightly soluble in *chloroform*; practically insoluble in *ether*. It dissolves in dilute solutions of alkali hydroxides and carbonate.

**Nicoumalone.** Slightly soluble in *ethanol* (95 per cent) and in *chloroform*; practically insoluble in *water* and in *ether*. It dissolves in aqueous solutions of alkali hydroxides.

**Nifedipine.** Freely soluble in *acetone* and in *chloroform*; sparingly soluble in *ethanol*; practically insoluble in *water*.

**Nikethamide.** Miscible with *water*, with *chloroform*, with *ethanol* (95 per cent) and with *ether*; slightly soluble in *carbon tetrachloride*.

**Nitrazepam.** Sparingly soluble in *chloroform*; slightly soluble in *ethanol* (95 per cent) and in *ether*; practically insoluble in *water*.

**Nitrofurantoin.** Soluble in *dimethylformamide*; very slightly soluble in *water* and in *ethanol* (95 per cent).

**Nitrfurazone.** Soluble in *dimethylformamide*; slightly soluble in *ethanol* (95 per cent); very slightly soluble in *water*; practically insoluble in *chloroform* and in *ether*.

**Nitrous Oxide.** At 20° and at a pressure of 101.3 kpa, 1 volume of gas dissolves in about 1.5 volumes of *water*; freely soluble in *ethanol* (95 per cent); soluble in *ether* and in oils.

**Nitroxyline.** Slightly soluble in *ethanol* (95 per cent); sparingly soluble in *ether*; practically insoluble in *water*. Freely soluble in solutions of alkalis hydroxide.

**Noradrenaline Bitartrate.** Freely soluble in *water*; slightly soluble in *ethanol* (95 per cent); practically insoluble in *chloroform* and in *ether*.

**Norethisterone.** Soluble in *chloroform*; slightly soluble in *ethanol* (95 per cent); practically insoluble in *water*.

**Norfloxacin.** Freely soluble in *acetic acid*; sparingly soluble in *chloroform*; slightly soluble in *acetone* and in *ethanol* (95 per cent); very slightly soluble in *water*, in *methanol* and in *ethyl acetone*; insoluble in *ether*.

**Norgestrel.** Freely soluble in *chloroform* and in *dichloromethane*; sparingly soluble in *ethanol* (95 per cent); insoluble in *water*.

**Nortriptyline Hydrochloride.** Freely soluble in *ethanol* (95 per cent) and in *chloroform*; sparingly soluble in *water* and in *methanol*; practically insoluble in *ether*, in *benzene* and in most other organic solvents.

**Noscapine.** Freely soluble in *chloroform*; soluble in *acetone*; slightly soluble in *ethanol* (95 per cent) and in *ether*; practically insoluble in *water*. It is soluble in strong acids. On dilution with *water*, the base may get precipitated.

**Novobiocin Sodium.** Freely soluble in *water*, in *ethanol* (95 per cent) and in *methanol*.

**Nystatin.** Freely soluble in *dimethylformamide*; slightly soluble in *methanol*; very slightly soluble in *water*; insoluble in *chloroform*, in *ether* and in *ethanol* (95 per cent).

**Oestradiol Benzoate.** Sparingly soluble in *acetone*; slightly soluble in *ethanol* (95 per cent) and in fixed oils; practically insoluble in *water*.



**Ofloxacin.** Soluble in *glacial acetic acid*; slightly soluble in *water*, *methylene chloride* and *methanol*.

**Olanzapine.** Practically insoluble in *water*; *dichloromethane*.

**Oleic Acid.** Miscible with *dichloromethane*, with *chloroform*, with *ethanol* (95 per cent), with *ether* and with light petroleum (boiling range 40° to 60°); practically insoluble in *water*.

**Omeprazole.** Freely soluble in *dichloromethane* and in *chloroform*; soluble in *ethanol* (95 per cent) and in *methanol*; very slightly soluble in *water*. It dissolves in dilute solutions of alkali hydroxides.

**Ormeloxifene Hydrochloride.** Soluble in *chloroform* and in *methanol*; sparingly soluble in *ethanol* (95 per cent); very slightly soluble in *water*.

**Oseltamivir Phosphate.** Soluble in *water*.

**Oxfendazole.** Slightly soluble in *methanol*, in *dichloromethane*, *acetone* and in *ether*; practically insoluble in *water*.

**Oxprenolol Hydrochloride.** Very soluble in *water*; freely soluble in *ethanol* (95 per cent); soluble in *chloroform*; practically insoluble in *ether*.

**Oxyclozanide.** Freely soluble in *acetone*; soluble in *ethanol* (95 per cent); slightly soluble in *dichloromethane*; very slightly soluble in *water*.

**Oxygen.** At 20° and at a pressure of 101 kPa, 1 volume of gas dissolves in about 32 volumes of *water*.

**Oxygen 93 Per Cent.** Soluble in *water* at 20° and at a pressure of 101 kPa.

**Oxyphenbutazone.** Freely soluble in *ethanol* (95 per cent); soluble in *acetone*, in *chloroform* and *ether*; practically insoluble in *water*. It dissolves in dilute solutions of alkali hydroxides.

**Oxytetracycline.** Sparingly soluble in *ethanol* (95 per cent); very slightly soluble in *water*. Dissolves in dilute acid and alkaline solutions.

**Oxytetracycline Hydrochloride.** Freely soluble in *water*, the solution becoming clouding on standing due to liberation of oxytetracycline base; sparingly soluble in *ethanol* (95 per cent); practically insoluble in *chloroform* and in *ether*.

**Oxytocin.** Soluble in *water*, in *1-butanol* and in *2-butanol* (for solid).

**Paclitaxel.** Insoluble in *water*; soluble in *ethanol* (95 per cent).

**Pancreatin.** Soluble in *water* producing a slightly turbid solution; practically insoluble in *ethanol* (95 per cent); and in *ether*.

**D-Panthenol.** Miscible with *water* and with *ethanol* (95 per cent); soluble in *chloroform*; slightly soluble in *ether*; insoluble in fats and oils.

**Papain.** Sparingly soluble in *water*; practically insoluble in *ethanol* (95 per cent), in *chloroform* and in *ether*.

**Paracetamol.** Freely soluble in *ethanol* (95 per cent) and in *acetone*; sparingly soluble in *water*; very slightly soluble in *dichloromethane* and in *ether*.

**Hard Paraffin.** Soluble in *chloroform* and in *ether*; practically insoluble in *ethanol* (95 per cent) and in *water*.

**Liquid Paraffin.** Soluble in *chloroform*, in *ether* and in *light petroleum* (40° to 60°); practically insoluble in *water* and in *ethanol* (95 per cent). Miscible with fixed and volatile oils.

**Light Liquid Paraffin.** Soluble in *chloroform* and in *ether*; practically insoluble in *water* and in *ethanol* (95 per cent); miscible with fixed and volatile oils.

**White Soft Paraffin.** Soluble in *chloroform*, in *ether* and in *light petroleum* (40° to 60°), the solutions sometimes showing a slight opalescence; practically insoluble in *ethanol* (95 per cent) and in *water*.

**Yellow soft paraffin.** Soluble in *chloroform*, in *ether* and in *light petroleum* (40° to 60°), the solutions sometimes showing a slight opalescence; practically insoluble in *ethanol* (95 per cent) and in *water*.

**Paraldehyde.** Soluble in *water*; miscible with *ethanol* (95 per cent), with *chloroform*, with *ether* and with volatile oils.

**Penicillamine.** Freely soluble in *water*; slightly soluble in *ethanol* (95 per cent); practically insoluble in *chloroform* and in *ether*.

**Pentamidine Isethionate.** Soluble in *water*; slightly soluble in *ethanol* (95 per cent); practically insoluble in *chloroform* and in *ether*.

**Pentazocine.** Freely soluble in *chloroform*; soluble in *ethanol* (95 per cent); sparingly soluble in *ether*; practically insoluble in *water*.

**Pentazocine Hydrochloride.** Freely soluble in *chloroform*; soluble in *ethanol* (95 per cent); sparingly soluble in *water*; practically insoluble in *ether*.

**Pentazocine Lactate.** Freely soluble in *methanol*; sparingly soluble in *chloroform*, in *ethanol* (95 per cent) and in *water*. It dissolves in aqueous solutions of alkali hydroxides.

**Pentobarbitone Sodium.** Very soluble in *water* and in *ethanol* (95 per cent); practically insoluble in *ether*.

**Peppermint Oil.** Freely soluble in *ethanol* (70 per cent). The solution may show an opalescence.

**Pepsin.** Soluble in *water*; practically insoluble in *ethanol* (95 per cent) and in *ether*. The solution in *water* may be slightly opalescent with a weakly acidic reaction.

**Pethidine Hydrochloride.** Very soluble in *water*; freely soluble in *chloroform* and in *ethanol* (95 per cent); practically insoluble in *ether*.

**Phenindamine Tartrate.** Sparingly soluble in *water*; slightly soluble in *ethanol* (95 per cent); practically insoluble in *chloroform* and in *ether*.

**Phenindione.** Freely soluble in *chloroform*; slightly soluble in *ethanol* (95 per cent) and in *ether*; very slightly soluble in *water*. Solutions are yellow to red.

**Pheniramine Maleate.** Freely soluble in *water*, in *chloroform* and in *ethanol* (95 per cent); very slightly soluble in *ether*.

**Phenobarbitone.** Soluble in *ethanol* (95 per cent) and in *ether*; sparingly soluble in *chloroform*; very slightly soluble in *water*. It is soluble in aqueous solutions of alkali hydroxides and carbonates.

**Phenobarbitone Sodium.** Freely soluble in carbon dioxide-free *water* (a small fraction may be insoluble); soluble in *ethanol* (95 per cent); practically insoluble in *dichloromethane* and in *ether*.

**Phenol.** Very soluble in *dichloromethane*, in *ethanol* (95 per cent) and in *glycerin*; soluble in *water*.

**Phenolphthalein.** Soluble in *ethanol* (95 per cent) and in *ether*; practically insoluble in *water*.

**Phenoxymethylpenicillin Potassium.** Freely soluble in *water*; slightly soluble in *ethanol* (95 per cent); practically insoluble in *chloroform*, in *ether*, in fixed oil and in *liquid paraffin*.

**Pentolamine Mesylate.** Freely soluble in *water* and in *ethanol* (95 per cent); slightly soluble in *chloroform*.

**Phenylbutazone.** Freely soluble in *chloroform* and in *acetone*; soluble in *ether*; sparingly soluble in *ethanol* (95 per cent); practically insoluble in *water*. It dissolves in solutions of alkali hydroxide.

**Phenylephrine Hydrochloride.** Freely soluble in *water* and in *ethanol* (95 per cent); practically insoluble in *chloroform*.

**Phenylmercuric Acetate.** Soluble in *acetone*; slightly soluble in *water* and in *ethanol* (95 per cent).

**Phenylmercuric Nitrate.** Slightly soluble in *ethanol* (95 per cent) and in *glycerin*; very slightly soluble in *water*; practically insoluble in other usual organic solvents. It is more soluble in the presence of either *nitric acid* or alkali hydroxides.

**Phenytoin Sodium.** Soluble in *water*, the solution showing some turbidity due to partial hydrolysis; soluble in *ethanol* (95 per cent); practically insoluble in *dichloromethane* and in *ether*.

**Pholcodine.** Very soluble in *chloroform* and in *acetone*; freely soluble in *ethanol* (95 per cent); slightly soluble in *ether*; sparingly soluble in *water*. It dissolves in dilute mineral acids.

**Phosphoric Acid.** Miscible with *water* and with *ethanol* (95 per cent).

**Physostigmine Salicylate.** Soluble in *ethanol* (95 per cent) and in *chloroform*; sparingly soluble in *water*; very slightly soluble in *ether*.

**Pilocarpine Nitrate.** Freely soluble in *water*; sparingly soluble in *ethanol* (95 per cent); practically insoluble in *chloroform* and in *ether*.

**Pindalol.** Slightly soluble in *methanol*; very slightly soluble in *chloroform*; practically insoluble in *water*. It dissolves in dilute mineral acids.

**Piperazine Adipate.** Soluble in *water*; practically insoluble in *ethanol* (95 per cent).

**Piperazine Citrate.** Freely soluble in *water*; practically insoluble in *ethanol* (95 per cent) and in *ether*.

**Piperazine Hydrate.** Freely soluble in *water* and in *ethanol* (95 per cent); slightly soluble in *ether*.

**Piperazine Phosphate.** Sparingly soluble in *water*; practically insoluble in *ethanol* (95 per cent).

**Piroxicam.** Slightly soluble in *ethanol* (95 per cent) and in aqueous alkaline solutions; very slightly soluble in *water*, in dilute acids and in most organic solvents.

**Plaster of Paris.** Slightly soluble in *water*, the solubility decreasing sharply with rise of temperature; practically insoluble in *ethanol* (95 per cent). It is more soluble in dilute mineral acids.

**Polyethylene Glycol 1500.** Freely soluble in *water* and in *chloroform*; sparingly soluble in *ethanol*; practically insoluble in *ether*.

**Polyethylene Glycol 4000.** Freely soluble in *water*, in *chloroform* and in *ethanol* (95 per cent); practically insoluble in *ether*.

**Polyethylene Glycol 6000.** Freely soluble in *water*, in *chloroform* and in *ethanol* (95 per cent); practically insoluble in *water*.

**Polysorbate 20.** Miscible with *water*; with *ethanol*, with *ethyl acetate* and with *methanol*; practically insoluble in fixed oils and in liquid paraffin.

**Polysorbate 80.** Miscible with *water*, with *ethanol*, with *ethyl acetate* and with *methanol*; practically insoluble in fixed oils and in liquid paraffin.

**Potassium Chloride.** Freely soluble in *water*, practically insoluble in *ethanol* and in *ether*.

**Potassium Citrate.** Very soluble in *water*, soluble in *glycerin*; practically insoluble in *ethanol* (95 per cent).

**Potassium Clavulanate.** Freely soluble in *water*; slightly soluble in *ethanol* (95 per cent); very slightly soluble in *acetone*.

**Potassium Iodide.** Very soluble in *water*; freely soluble in *glycerin*; soluble in *ethanol* (95 per cent).

**Potassium Permanganate.** Soluble in cold *water*; freely soluble in boiling *water*.

**Povidone.** Freely soluble in *water*, in *chloroform* and in *ethanol* (95 per cent); practically insoluble in *ether*.

**Povidone Iodine.** Soluble in *water* and in *ethanol* (95 per cent); practically insoluble in *chloroform*, in *acetone* and in *ether*.

**Pralidoxime Chloride.** Freely soluble in *water*; sparingly soluble in *ethanol* (95 per cent).

**Prazosin Hydrochloride.** Slightly soluble in *methanol*, in *ethanol*, (95 per cent), *dimethylformamide* and in *dimethylacetamide*; very slightly soluble in *water*; practically insoluble in *chloroform* and in *acetone*.

**Prednisolone.** Soluble in *ethanol* (95 per cent) and in *methanol*; sparingly soluble in *acetone*; slightly soluble in *chloroform*; very slightly soluble in *water*.

**Prednisolone Sodium Phosphate.** Freely soluble in *water*; very slightly soluble in *ethanol* (95 per cent).

**Prednisone.** Slightly soluble in *chloroform* and in *ethanol* (95 per cent); practically insoluble in *water*.

**Primaquine Phosphate.** Soluble in *water*; practically insoluble in *ethanol* (95 per cent) and in *ether*.

**Probenecid.** Soluble in *acetone*; sparingly soluble in *chloroform* and in *ethanol* (95 per cent); slightly soluble in *ether*; practically insoluble in *water* and in dilute acids. It is soluble in dilute alkalis.

**Procainamide Hydrochloride.** Very soluble in *water*, freely soluble in *ethanol* (95 per cent); slightly soluble in *acetone* and in *chloroform*; practically insoluble in *ether*.

**Procaine Hydrochloride.** Very soluble in *water*; soluble in *ethanol* (95 per cent); slightly soluble in *chloroform*; practically insoluble in *ether*.

**Procaine Penicillin.** Slightly soluble in *water*; sparingly soluble in *ethanol* (95 per cent).

**Prochlorperazine Maleate.** Very slightly soluble in *water* and in *ethanol* (95 per cent) practically insoluble in *chloroform* and in *ether*.

**Prochlorperazine Mesylate.** Very soluble in *water*; sparingly soluble in *ethanol* (95 per cent); slightly soluble in *chloroform*; practically insoluble in *ether*.

**Progesterone.** Very soluble in *dichloromethane*; freely soluble in *ethanol*; sparingly soluble in *acetone*, in *ether* and in fixed oils; practically insoluble in *water*.

**Proguanil Hydrochloride.** Soluble in *ethanol* (95 per cent); slightly soluble in *water*; practically insoluble in *chloroform* and in *ether*.

**Promazine Hydrochloride.** Freely soluble in *water*, in *ethanol* (95 per cent) and in *dichloromethane*.

**Promethazine Hydrochloride.** Very soluble in *water*; freely soluble in *chloroform* and in *ethanol* (95 per cent); practically insoluble in *ether*.

**Promethazine Theoclate.** Freely soluble in *chloroform*; sparingly soluble in *ethanol* (95 per cent); very slightly soluble in *water*; practically insoluble in *ether*.

**Propanteline Bromide.** Very soluble in *water*, in *ethanol* (95 per cent) and in *chloroform*; practically insoluble in *ether*.

**Propranolol Hydrochloride.** Soluble in *water* and in *ethanol* (95 per cent); slightly soluble in *chloroform*; practically insoluble in *ether*.

**Propyl Gallate.** Freely soluble in *ethanol* (95 per cent) and in *ether*; very slightly soluble in *water* and in arachis oil.

**Propylene Glycol.** Miscible with *water*, with *ethanol* (95 per cent), with *acetone* and with *chloroform*.

**Propylparaben.** Freely soluble in *ethanol* (95 per cent), in *acetone*, in *ether*, and in *methanol*; very slightly soluble in *water*.

**Propylthiouracil.** Sparingly soluble in *methanol*, in *ethanol* (95 per cent); very slightly soluble in *ether* and in *water*. It dissolves in aqueous solutions of alkali hydroxides.

**Propyphenazone.** Freely soluble in *dichloromethane* and in *ethanol* (95 per cent); soluble in *ether*; slightly soluble in *water*.

**Protamine Sulphate.** Sparingly soluble in *water*; practically insoluble in *chloroform*, in *ethanol* (95 per cent) and in *ether*.

**Prothionamide.** Soluble in *ethanol* (95 per cent), *methanol*; slightly soluble in *ether*, *chloroform* and practically insoluble in *water*.

**Pseudoephedrine Hydrochloride.** Very soluble in *water*; freely soluble in *ethanol* (95 per cent); sparingly soluble in *chloroform*.

**Psoralen.** Very soluble in *chloroform*; soluble in *ethanol* (95 per cent); sparingly soluble in *ether*; practically insoluble in *light petroleum* (60° to 80°).

**Pyrazinamide.** Sparingly soluble in *water* and in *chloroform*; slightly soluble in *ethanol* (95 per cent); very slightly soluble in *ether*.

**Pyridoxine Hydrochloride.** Freely soluble in *water*; slightly soluble in *ethanol* (95 per cent); practically insoluble in *chloroform* and in *ether*.

**Pyrimethamine.** Slightly soluble in *chloroform* and in *ethanol* (95 per cent); very slightly soluble in *ether*; practically insoluble in *water*.



**Quinalbarbitone Sodium.** Freely soluble in *carbon dioxide-free water* and in *ethanol (95 per cent)*; practically insoluble in *chloroform* and in *ether*.

**Quinidine Sulphate.** Soluble in *ethanol (95 per cent)* and in *chloroform*; sparingly soluble in *water*; practically insoluble in *ether*.

**Quinine Bisulphate.** Freely soluble in boiling *water* and in boiling *ethanol (95 per cent)*; soluble in *water*; sparingly soluble in *ethanol (95 per cent)*; slightly soluble in *chloroform*.

**Quinine Dihydrochloride.** Very soluble in *water*; soluble in *ethanol (95 per cent)*; slightly soluble in *chloroform*; very slightly soluble in *ether*.

**Quinine Sulphate.** Freely soluble in a mixture of 2 volumes of *chloroform* and 1 volume of *ethanol*; sparingly soluble in boiling *water* and in *ethanol (95 per cent)*; slightly soluble in *water*; very slightly soluble in *chloroform*; practically insoluble in *ether*.

**Quiniodochlor.** Freely soluble in *dimethylformamide* and in *pyridine*; practically insoluble in *ethanol (95 per cent)* and in *water*.

**Rabeprazole Sodium.** Soluble in *water*.

**Rafoxanide.** Soluble in *acetone*; sparingly soluble in *dichloromethane* and in *ethyl acetate*; slightly soluble in *methanol*; practically insoluble in *water*.

**Ramipril.** Sparingly soluble in *water*; freely soluble in *methanol*.

**Ranitidine Hydrochloride.** Freely soluble in *water*; soluble in *methanol* and in *ethanol (95 per cent)*; sparingly soluble in *ethanol*; very slightly soluble in *chloroform* and in *dichloromethane*.

**Purified Rayon.** Very soluble in dilute *sulphuric acid*; insoluble in ordinary solvents.

**Reserpine.** Freely soluble in *chloroform*; very slightly soluble in *ethanol (95 per cent)*; practically insoluble in *ether* and in *water*.

**Riboflavine.** Very slightly soluble in *water*; more soluble in *saline solution* than in *water*; practically insoluble in *chloroform*, in *ethanol (95 per cent)* and in *ether*.

**Riboflavine Sodium Phosphate.** Soluble in *water*; very slightly soluble in *ethanol (95 per cent)*; practically insoluble in *ether*.

**Rifampicin.** Soluble in *chloroform* and in *methanol*; slightly soluble in *acetone*, in *ethanol (95 per cent)*, in *ether* and in *water*.

**Ritonavir.** Freely soluble in *methanol* and in *ethanol (95 per cent)*; soluble in *2-propanol*.

**Ronidazole.** Slightly soluble in *water*, in *ethanol (95 per cent)* and *dichloromethane*; very slightly soluble in *ether*.

**Rosiglitazone Maleate.** Freely soluble in *dimethylsulphoxide*; soluble in *methanol* and sparingly soluble in *acetone*.

**Rosuvastatin Calcium.** Soluble in *acetonitrile*, and slightly soluble in *acetone*.

**Roxithromycin.** Very slightly soluble in *water*; freely soluble in *acetone*, *ethanol (95 per cent)* and *methylene chloride*.

**Saccharin.** Sparingly soluble in boiling *water* and in *ethanol (95 per cent)*; slightly soluble in *chloroform*, in cold *water* and in *ether*. It dissolves in *dilute ammonia solution*, in solutions of alkali hydroxides and in carbonates.

**Saccharin Sodium.** Freely soluble in *water*; sparingly soluble in *ethanol (95 per cent)*; practically insoluble in *ether*.

**Salbutamol.** Soluble in *ethanol (95 per cent)*; sparingly soluble in *water*; slightly soluble in *ether*.

**Salbutamol Sulphate.** Freely soluble in *water*; slightly soluble in *ethanol (95 per cent)* and in *ether*; very slightly soluble in *dichloromethane*.

**Saquinavir.** Soluble in *methanol*.

**Saquinavir mesylate.** Soluble in *methanol*.

**Salicylic Acid.** Freely soluble in *ethanol (95 per cent)* and in *ether*; sparingly soluble in *chloroform*; slightly soluble in *water*.

**Salmeterol Xinafoate.** Practically insoluble in *water*; soluble in *methanol*.

**Shellac.** Soluble in warm *ethanol (95 per cent)*; practically insoluble in *water*. Almost completely soluble in solutions of alkali hydroxides and of *borax*.

**Colloidal Silicon Dioxide.** Practically insoluble in *water* and in mineral acids with the exception of *hydrofluoric acid*. Dissolves in hot solutions of alkali hydroxides. When 1 g is shaken vigorously with 20 ml of *carbon tetrachloride* for 3 minutes; a transparent gel is produced.

**Silver Nitrate.** Very soluble in *water*; soluble in *ethanol (95 per cent)*.

**Sodium Acetate.** Very soluble in *water*; soluble in *ethanol (95 per cent)*.

**Sodium Alginate.** Slowly soluble in *water* forming a viscous, colloidal solution; practically insoluble in *ethanol (95 per cent)* and in *ether*.

**Sodium Aminosalicylate.** Freely soluble in *water*; sparingly soluble in *ethanol (95 per cent)*; very slightly soluble in *chloroform* and in *ether*.

**Sodium Ascorbate.** Freely soluble in *water*; very slightly soluble in *ethanol (95 per cent)*; practically insoluble in *chloroform* and in *ether*.

**Sodium Aurothiomalate.** Very soluble in *water*; insoluble in *ethanol (95 per cent)* and in *ether*.



**Sodium Benzoate.** Freely soluble in *water*; sparingly soluble in *ethanol* (95 per cent).

**Sodium Bicarbonate.** Freely soluble in *water*; practically insoluble in *ethanol* (95 per cent).

**Sodium Carbonate.** Freely soluble in *water*; practically insoluble in *ethanol* (95 per cent).

**Sodium Carboxymethyl Cellulose.** Practically insoluble in *acetone*, in *ethanol*, in *ether* and in *toluene*. It is easily dispersed in *water* forming a colloidal solution.

**Sodium Chloride.** Freely soluble in *water* and slightly more soluble in boiling *water*; practically insoluble in *ethanol*.

**Sodium Citrate.** Freely soluble in *water*; practically insoluble in *ethanol* (95 per cent) and in *ether*.

**Sodium Cromoglycate.** Soluble in *water*; practically insoluble in *chloroform*, in *ethanol* (95 per cent) and in *ether*.

**Sodium Diatrizoate.** Freely soluble in *water*; slightly soluble in *ethanol* (95 per cent); practically insoluble in *acetone* and in *ether*.

**Sodium Dihydrogen Phosphate Dihydrate.** Very soluble in *water*, very slightly soluble in *ethanol* (95 per cent).

**Sodium Fluoride.** Soluble in *water* practically insoluble in *ethanol* (95 per cent).

**Sodium Formaldehyde Sulphoxylate.** Freely soluble in *water*; slightly soluble in *chloroform*, in *ethanol* (95 per cent) and in *ether*.

**Sodium Fusidate.** Freely soluble in *water* and in *ethanol* (95 per cent); slightly soluble in *chloroform*; practically insoluble in *acetone* and in *ether*.

**Sodium Hydroxide.** Very soluble in *water*; freely soluble in *ethanol* (95 per cent).

**Sodium Lauryl Sulphate.** Freely soluble in *water*, forming an opalescent solution; partly soluble in *ethanol* (95 per cent).

**Sodium Metabisulphite.** Freely soluble in *water*; slightly soluble in *ethanol* (95 per cent).

**Sodium Methylparaben.** Freely soluble in *water*; sparingly soluble in *ethanol* (95 per cent); practically insoluble in fixed oils.

**Sodium Phosphate.** Very soluble in *water*; practically insoluble in *ethanol* (95 per cent).

**Sodium Propylparaben.** Freely soluble in *water* and in *ethanol* (50 per cent); sparingly soluble in *ethanol* (95 per cent); practically insoluble in fixed oils.

**Sodium Salicylate.** Freely soluble in *water* (concentrated solutions are liable to deposit crystals of the hexahydrate) and in *ethanol* (95 per cent); practically insoluble in *ether*.

**Sodium Starch Glycollate.** Practically insoluble in *water*, insoluble in most organic solvents.

**Sodium Stibogluconate.** Very soluble in *water*; practically insoluble in *ethanol* (95 per cent) and in *ether*.

**Sodium Thiosulphate.** Very soluble in *water*; practically insoluble in *ethanol* (95 per cent).

**Sodium Valporate.** Very soluble in *water* and in *ethanol* (95 per cent); practically insoluble in *ether*.

**Sorbic Acid.** Freely soluble in *ethanol* (95 per cent) and in *ether*; slightly soluble in *water*.

**Sorbitol.** Very soluble in *water*; sparingly soluble in *ethanol* (95 per cent) practically insoluble in *chloroform* and in *ether*.

**Sorbitol Solution (70 Per cent) (Non-crystallising).** Miscible with *water*, with *glycerin* and with *1,2-propanediol*.

**Spectinomycin Hydrochloride.** Soluble in *water*; practically insoluble in *dichloromethane*, in *ethanol* (95 per cent) and in *ether*.

**Spiranmycin.** Freely soluble in *ethanol*, in *methanol* and in *acetone*; slightly soluble in *water*; sparingly soluble in *ether*.

**Spirolactone.** Freely soluble in *chloroform*; soluble in *ethanol* (95 per cent); slightly soluble in *ether*; practically insoluble in *water*.

**Starch.** Practically insoluble in cold *water* and in *ethanol* (95 per cent).

**Stavudine.** Sparingly soluble in *water*; soluble in *ethanol* (95 per cent).

**Stearic Acid.** Soluble in *chloroform*, in *ethanol* and in *ether*; practically insoluble in *water*.

**Stearyl Alcohol.** Freely soluble in *chloroform* and in *ether*; soluble in *ethanol* (95 per cent); practically insoluble in *water*.

**Stilboestrol.** Freely soluble in *ethanol* (95 per cent) and in *ether*; sparingly soluble in arachis oil; very slightly soluble in *water*. It is soluble in aqueous solutions of alkali hydroxides.

**Prepared Storax.** Soluble in *ethanol* (95 per cent) and in *ether*; practically insoluble in *water*.

**Streptokinase.** Freely soluble in *water*.

**Streptomycin Sulphate.** Very soluble in *water*; slightly soluble in *ethanol* (95 per cent); practically insoluble in *chloroform* and in *ether*.

**Succinylcholine Chloride.** Freely soluble in *water*; slightly soluble in *ethanol* (95 per cent); practically insoluble in *chloroform* and in *ether*.

**Sucrose.** Very soluble in *water*; freely soluble in *ethanol* (70 per cent); practically insoluble in *ethanol*.

**Sulphacetamide Sodium.** Freely soluble in *water*; slightly soluble in *ethanol* (95 per cent); practically insoluble in *chloroform* and in *ether*.

**Sulphadiazine.** Slightly soluble in *acetone*; very slightly soluble in *ethanol* (95 per cent); practically insoluble in *chloroform* and in *water*. It dissolves in solutions of alkali hydroxides and in dilute mineral acids.

**Sulphadimethoxine.** Slightly soluble in *ethanol* (95 per cent); very slightly soluble in *water*. It dissolves in solutions of alkali hydroxides and carbonates.

**Sulphadimidine.** Soluble in *acetone*; slightly soluble in *ethanol* (95 per cent); very slightly soluble in *water*; practically insoluble in *ether*. It dissolves in dilute mineral acids and in solutions of alkali hydroxides.

**Sulphadimidine Sodium.** Very freely soluble in *water*; sparingly soluble in *ethanol* (95 per cent).

**Sulphadoxine.** Slightly soluble in *ethanol* (95 per cent) and in *methanol*; very slightly soluble in *water*; practically insoluble in *ether*. It dissolves in solutions of alkali hydroxides and in dilute mineral acids.

**Sulphafurazole.** Sparingly soluble in *ethanol* (95 per cent); slightly soluble in *dichloromethane* and in *ether*; practically insoluble in *water*. It dissolves in solutions of alkali hydroxides and in dilute mineral acids.

**Sulphalene.** Soluble in *acetone*; slightly soluble in *ethanol* (95 per cent); very slightly soluble in *water*. It dissolves in aqueous solutions of alkali hydroxides.

**Sulphamethizole.** Soluble in *acetone*; sparingly soluble in *ethanol* (95 per cent); very slightly soluble in *water*; in *chloroform* and in *ether*. It dissolves in dilute solutions of alkali hydroxides and in dilute mineral acids.

**Sulphamethoxazole.** Freely soluble in *acetone*; sparingly soluble in *ethanol* (95 per cent); slightly soluble in *chloroform* and in *ether*; practically insoluble in *water*. It dissolves in dilute solutions of *sodium hydroxide*.

**Sulphaphenazole.** Very slightly soluble in *water*, in *ethanol* (95 per cent), in *ether* and in *chloroform*. It dissolves in aqueous solutions of alkali hydroxides and in mineral acids.

**Sulphaquinoxaline.** Very slightly soluble in *ethanol* (95 per cent); practically insoluble in *water* and in *ether*. Freely soluble in aqueous solutions of alkalis.

**Sulphathiazole Sodium.** Freely soluble in *water*; soluble in *ethanol* (95 per cent).

**Sulphobromophthalein Sodium.** Soluble in *water*; practically insoluble in *ethanol* (95 per cent) and in *acetone*.

**Talc.** Practically insoluble in *water* and in dilute solutions of acids and in alkali hydroxides.

**Tamoxifen Citrate.** Soluble in *methanol*; very slightly soluble in *water*, in *acetone*, in *chloroform* and in *ethanol* (95 per cent).

**Tartaric Acid.** Very soluble in *water*; freely soluble in *ethanol* (95 per cent).

**Terbutaline Sulphate.** Freely soluble in *water*; slightly soluble in *ethanol* (95 per cent); practically insoluble in *chloroform* and in *ether*.

**Testosterone Propionate.** Very soluble in *chloroform*; freely soluble in *acetone*, in *ethanol* (95 per cent) and in *methanol*; practically insoluble in *water*, soluble in fixed oils.

**Tetracycline.** Soluble in *ethanol* (95 per cent) and in *methanol*; sparingly soluble in *acetone*; slightly soluble in *chloroform*; very slightly soluble in *water*; practically insoluble in *ether*. It dissolves in dilute acid and alkaline solutions.

**Tetracycline Hydrochloride.** Freely soluble in *water*; slightly soluble in *ethanol* (95 per cent); practically insoluble in *acetone*, in *chloroform* and in *ether*. It dissolves in aqueous solutions of alkali hydroxides and carbonates.

**Theophylline.** Sparingly soluble in *ethanol*; slightly soluble in *chloroform* and *water*; very slightly soluble in *ether*. It dissolves in solutions of alkali hydroxides, in aqueous ammonia and in mineral acids.

**Thiabendazole.** Slightly soluble in *ethanol* (95 per cent), in *dichloromethane*, in *chloroform* and in *ether*; practically insoluble in *water*. It dissolves in dilute mineral acid.

**Thiacetazone.** Soluble in *1,2-propanediol*; slightly soluble in *ethanol* (95 per cent); very slightly soluble in *water*.

**Thiamine Hydrochloride.** Freely soluble in *water*; slightly soluble in *ethanol* (95 per cent); practically insoluble in *chloroform* and in *ether*.

**Thiamine Mononitrate.** Sparingly soluble in *water*; slightly soluble in *ethanol* (95 per cent) and in *methanol*.

**Thiomersal.** Freely soluble in *water* and in *ethanol* (95 per cent); practically insoluble in *ether*.

**Thiopentone Sodium.** Freely soluble in *water*; partly soluble in *ethanol* (95 per cent); practically insoluble in *benzene* and in *ether*.

**Thiotepa.** Freely soluble in *water*, in *ethanol* (95 per cent), in *chloroform* and in *ether*.

**Thymol.** Very soluble in *ethanol* (95 per cent) and in *ether*; very slightly soluble in *water*. Freely soluble in volatile oils and in fixed oils. It dissolves in dilute solutions of alkali hydroxides.

**Thyroxine Sodium.** Slightly soluble in *ethanol* (95 per cent); very slightly soluble in *water*; practically insoluble in *ether*. It dissolves in aqueous solutions of alkali hydroxides.

**Timolol Maleate.** Soluble in *water* and in *ethanol* (95 per cent); sparingly soluble in *chloroform*; practically insoluble in *ether*.

**Tinidazole.** Sparingly soluble in *water*; slightly soluble in *ethanol* (95 per cent), in *chloroform* and in *ether*.

**Titanium Dioxide.** Practically insoluble in *water* and in dilute mineral acids, slowly soluble in hot *sulphuric acid*.

**Tizanidine Hydrochloride.** Slightly soluble in *water* and *methanol*.

**Tobramycin.** Freely soluble in *water*; very slightly soluble in *ethanol* (95 per cent); practically insoluble in *chloroform* and in *ether*.

**Tocopheryl Acetate.** Freely soluble in *acetone*, in *chloroform* in *ethanol* (95 per cent), in *ether* and in fixed oils; soluble in *ethanol*; practically insoluble in *water*.

**Tolbutamide.** Soluble in *ethanol* (95 per cent), in *acetone* and in *chloroform*; slightly soluble in *ether*; practically insoluble in *water*. It dissolves in dilute solutions of alkali hydroxides.

**Tolu Balsam.** Freely soluble in *ether*, in *ethanol* (95 per cent), in *chloroform* and in solutions of fixed alkalies usually leaving some insoluble residue; insoluble in *water* and in *hexane*.

**Topotecan Hydrochloride.** Soluble in *water*.

**Triamcinolone.** Sparingly soluble in *ethanol* (95 per cent); slightly soluble in *water*; very slightly soluble in *chloroform* and in *ether*.

**Triamcinolone Acetonide.** Sparingly soluble in *chloroform* and in *ethanol* (95 per cent); very slightly soluble in *ether*; practically insoluble in *water*.

**Triamterene.** Very slightly soluble in *water*, in *chloroform* and in *ethanol* (95 per cent); practically insoluble in *water*.

**Trifluoperazine Hydrochloride.** Freely soluble in *water*; soluble in *ethanol* (95 per cent); slightly soluble in *chloroform*; insoluble in *ether* and in *benzene*.

**Triflupromazine Hydrochloride.** Soluble in *water*, in *ethanol* (95 per cent) and in *acetone*; insoluble in *ether*.

**Trimethoprim.** Sparingly soluble in *chloroform*; slightly soluble in *ethanol* (95 per cent); very slightly soluble in *water*; practically insoluble in *ether*.

**Tripolidine Hydrochloride.** Very soluble in *chloroform*; freely soluble in *water* and in *ethanol* (95 per cent); practically insoluble in *ether*.

**Tropicamide.** Freely soluble in *chloroform*, in *ethanol* (95 per cent) and in solutions of strong acids; slightly soluble in *water*.

**Troxidone.** Very soluble in *chloroform*, in *ethanol* (95 per cent) and in *ether*; soluble in *water*.

**Tubocurarine Chloride.** Soluble in *water* and in *ethanol* (95 per cent); practically insoluble in *acetone*, in *chloroform* and in *ether*. It dissolves in solutions of alkali hydroxides.

**Tylosine.** Freely soluble in *methanol*; soluble in *ethanol* (95 per cent) and in *dichloromethane*; slightly soluble in *water*. It dissolves in dilute mineral acids.

**Tylosine Tartrate.** Freely soluble in *water* and in *dichloromethane*; slightly soluble in *ethanol* (95 per cent); practically insoluble in *ether*. It Dissolve in dilute solutions of mineral acids.

**Undecenoic Acid.** Freely soluble in *chloroform*, in *ethanol* (95 per cent) in *ether* and in fixed and in volatile oils; practically insoluble in *water*.

**Urea.** Freely soluble in *water* and in boiling *ethanol* (95 per cent); soluble in *ethanol* (95 per cent); practically insoluble in *chloroform*, in *dichloromethane* and in *ether*.

**Urokinase.** Soluble in *water*.

**Vinblastine Sulphate.** Freely soluble in *water*; soluble in *methanol*; practically insoluble in *ethanol* (95 per cent) and in *ether*.

**Vincristine Sulphate.** Freely soluble in *water*; soluble in *methanol*; slightly soluble in *ethanol* (95 per cent); practically insoluble in *ether*.

**Vinorolbine Tartrate.** Freely soluble in *water*.

**Vanillin.** Freely soluble in *ethanol* (95 per cent) and in *methanol*; soluble in *ether*; slightly soluble in *water*. It dissolves in dilute solutions of alkali hydroxides.

**Verapamil Hydrochloride.** Freely soluble in *chloroform*; soluble in *water*; sparingly soluble in *ethanol* (95 per cent); practically insoluble in *ether*.

**Vitamin A Concentrate (Oily Form).** Soluble or partly soluble in *ethanol*; miscible with organic solvents; practically insoluble in *water*. Partial crystallisation may occur in highly concentrated solutions.

**Vitamin A Concentrate (Powder Form).** Depending on the formulation, may be practically insoluble in *water*, swell or form an emulsion.

**Warfarin Sodium.** Very soluble in *water* and in *ethanol* (95 per cent); soluble in *acetone*; very slightly soluble in *dichloromethane* and in *ether*.

**Wool Fat.** Soluble in *chloroform* and in *ether*, slightly soluble in boiling *ethanol* (95 per cent); practically insoluble in *water*.

**Hydrous Wool Fat.** Soluble in *chloroform* and in *ether*, with the separation of *water*; practically insoluble in *water*.

**Xylometazoline Hydrochloride.** Freely soluble in *ethanol* (95 per cent); soluble in *water* and in *chloroform*; practically insoluble in *ether*.

**Xylose.** Very soluble in *water*; soluble in hot *ethanol* (95 per cent).

**Zinc Chloride.** Very soluble in *water*; freely soluble in *ethanol* (95 per cent) and in *glycerin*.

**Zinc Oxide.** Practically insoluble in *water* and in *ethanol* (95 per cent). It dissolves in dilute mineral acids.

**Zinc Stearate.** Practically insoluble in *water*; in *ethanol* (95 per cent) and in *ether*.

**Zinc Sulphate.** Very soluble in *water*; practically insoluble in *ethanol* (95 per cent).

**Zinc Undecenoate.** Practically insoluble in *water*; in *ethanol* (95 per cent) and in *ether*.

### 2.4.27. Refractive Index

The refractive index ( $n$ ) of a substance with reference to air is the ratio of the sin of the angle of incidence to the sin of the angle of refraction of a beam of light passing from air into the substance. It varies with the wavelength of the light used in its measurement.

Unless otherwise specified in the individual monograph, the refractive index,  $n_D^{20}$  is measured at  $20^\circ \pm 0.5^\circ$  with reference to the wavelength of the D-line of sodium ( $\lambda = 589.3$  nm). The temperature should be carefully adjusted and maintained since the refractive index varies significantly with temperature.

The Abbe refractometer is convenient for most measurements of refractive index but other refractometers of equal or greater accuracy may be used. Commercial refractometers are normally constructed for use with white light but are calibrated to give the refractive index in terms of the D line of sodium. The apparatus is provided with a water jacket to control the temperature of measurements. The manufacturer's instructions relating to a suitable light source should be followed subject to the directions given in the Pharmacopoeia. To achieve accuracy, the apparatus should be calibrated against *distilled water* which has a refractive index of 1.3325 at  $25^\circ$  or against the reference liquids given in the following table.

Reference liquid	$n_D^{20}$	Temperature coefficient $\Delta n/\Delta t$
Carbon tetrachloride	1.4603	-0.00057
Toluene	1.4969	-0.00056
$\alpha$ -Methylnaphthalene	1.6176	-0.00048

\*Refractive index value for the D line of sodium measured at  $20^\circ$ .

**NOTE** — The cleanliness of the instrument should be checked frequently by determining the refractive index of distilled water.

### 2.4.28. Viscosity

The determination of viscosity of newtonian liquids is carried out by means of a capillary viscometer, unless otherwise specified; Methods A and B described below are recommended. For non-newtonian liquids Method C using the rotating viscometer may be used.

For measurement of viscosity, the temperature of the substance being measured must be accurately controlled, since small temperature changes may lead to marked changes in viscosity. For usual pharmaceutical purposes, the temperature should be maintained to within  $\pm 0.1^\circ$ .

#### Method A (Using Ostwald-type Viscometer)

##### Apparatus

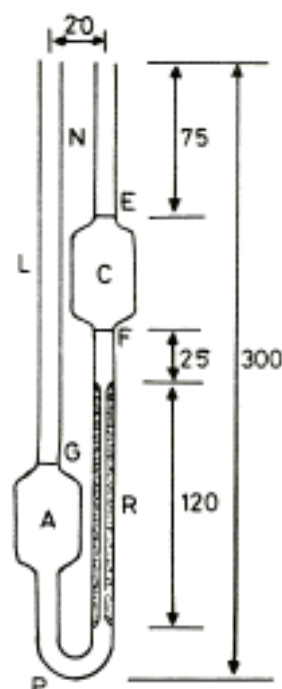

(Dimension in mm; tolerances  $\pm 10$  per cent)

Fig. 2.4.28-1: Ostwald-Type Viscometer

The apparatus consists of a glass U-tube viscometer (see Fig. 2.4.28-1) made of clear borosilicate glass and constructed in accordance with the dimensions shown in the figure and in Table 1.

**Procedure.** Fill the viscometer, previously washed and completely dried, with the liquid under examination through tube L to slightly above the mark G, using a long pipette to minimise wetting the tube above the mark. Place the tube vertically in a water-bath maintained at the temperature indicated in the monograph and allow to stand for not less than 30 minutes to allow the temperature to reach equilibrium. Adjust the volume of the liquid so that the bottom of the meniscus settles at the mark G. Suck or blow the liquid to a point about 5 mm above the mark E. After releasing pressure



Table 1—U-Tube Viscometer- Dimensions

Size	National viscometer constant $\text{m}^2\text{s}^{-2}$	Kinematic viscosity range $\text{mm}^2\text{s}^{-1}$	Inside diameter of tube R mm ( $\pm 2$ per cent)	Outside diameter of tubes*			Volume of bulb C ml ( $\pm 5$ per cent)	Vertical distance F to G mm	Outside diameter of bulbs A and C mm
				L	and	PN			
A**	0.003	0.9 to 3	0.50	8 to 9		6 to 7	5.0	91 $\pm$ 4	21 to 23
B	0.01	2.0 to 10	0.71	8 to 9		6 to 7	5.0	87 $\pm$ 4	21 to 23
C	0.03	6 to 30	0.88	8 to 9		6 to 7	5.0	83 $\pm$ 4	21 to 23
D	0.1	20 to 100	1.40	9 to 10		7 to 8	10.0	78 $\pm$ 4	25 to 27
E	0.3	60 to 300	2.00	9 to 10		7 to 8	10.0	73 $\pm$ 4	25 to 27
F	1.0	200 to 1000	2.50	9 to 10		7 to 8	10.0	70 $\pm$ 4	25 to 27
G	3.0	600 to 3000	4.00	10 to 11		9 to 10	20.0	60 $\pm$ 3	32 to 35
H	10.0	2000 to 10,000	6.10	10 to 11		9 to 10	20.0	50 $\pm$ 3	32 to 35

\* Use 1 to 1.25 mm wall tubing for N, P and L.

\*\* 300 s minimum flow time; 200 s minimum flow time for all other sizes.

or suction, measure the time taken for the bottom of the meniscus to fall from the top edge of mark E to the top edge of mark F.

Calculate, as required, either the kinematic viscosity ( $\nu$ ) in square millimetres per second ( $\text{mm}^2 \text{s}^{-1}$ ) from the expression

$$\nu = Kt,$$

or the dynamic viscosity ( $h$ ) in millipascal seconds (mPa s) from the expression

$$n = KPt,$$

where,  $t$  = time in seconds for the meniscus to fall from E to F,

$P$  = mass/volume ( $\text{g cm}^{-3}$ ) obtained by multiplying the relative density (2.4.29), of the liquid under examination by 0.998203.

The constant ( $K$ ) of the instrument is determined on a liquid of known viscosity.

*NOTE — For Dextran Injections, the viscosity ratio is calculated by dividing the time taken with the liquid under examination by the time taken by saline solution for the meniscus to fall from E to F.*

**Method B:** (Using the Suspended-level Viscometer)

#### Apparatus

The apparatus consists of a glass suspended-level viscometer (see Fig. 2.4.28-2) made of clear borosilicate glass and constructed in accordance with the dimensions shown in the figure and in Table 2.

Table 2 – Suspended-level Viscometer- Dimensions

Size	National viscometer constant $\text{m}^2\text{s}^{-2}$	Kinematic viscosity range $\text{mm}^2\text{s}^{-1}$	Inside diameter of tube R mm (2 per cent)	Volume of bulb C mm	Inside diameter of tube N mm
1*	0.01	3.5 to 10	0.64	5.6	2.8 to 3.2
1A	0.03	6 to 30	0.84	5.6	2.8 to 3.2
2	0.1	20 to 100	1.15	5.6	2.8 to 3.2
2A	0.3	60 to 300	1.51	5.6	2.8 to 3.2
3	1.0	200 to 1100	2.06	5.6	3.7 to 4.3
3A	3.0	600 to 3000	2.74	5.6	4.6 to 5.4
4	10.0	2000 to 10,000	3.70	5.6	4.6 to 5.4
4A	30.0	6000 to 30,000	4.97	5.6	5.6 to 6.4
5	100.0	20,000 to 100,000	6.76	5.6	6.8 to 7.5

\* 350 s minimum flow times; 200 s minimum flow time for all other sizes.



**Relative Density**

The relative density of a substance is the ratio of the mass of a given volume of the substance to the mass of an equal volume of *water*, both weighed at 25°, unless otherwise specified.

**Method**

Proceed as described under Weight per millilitre. Divide the weight of the substance in the pycnometer by the weight of *water* contained, both determined at 25°, unless otherwise directed in the individual monograph.

**2.4.30. Total Organic Carbon in Water**

This method for determining total organic carbon (TOC) indirectly measures the total amount of organic substances present in water for pharmaceutical use. The molecules of organic matter in water are oxidised to produce carbon dioxide which is then measured in an instrument and from the result, the concentration of carbon in the water is calculated. The determination of carbon in water may be made either on-line (in the line of supply of the water) or off-line.

Irrespective of the method used, the system is qualified by analysing a standard solution of a substance that is easily oxidisable (such as sucrose) at a concentration adjusted to give an instrument response corresponding to the TOC limit to be measured, and by interpreting the results in limit tests. The suitability of the system is determined by analysis of a solution prepared with a substance that is oxidisable with difficulty (such as 1,4-benzoquinone).

**Apparatus.** Any suitable apparatus capable of discriminating between organic and inorganic carbon either by purging inorganic carbon from the sample under examination before oxidation or by the measurement of the inorganic carbon and subtraction from the total carbon, may be used.

The instrument manufacturer's instructions should be followed for installation and subsequent operations. The instrument should be calibrated and the system suitability should be verified at suitable intervals. The apparatus must have a limit of detection specified by the manufacturer of 0.05 mg or less of carbon per litre.

**Glassware.** Use glassware that has been thoroughly cleaned by a method that will remove organic matter (5.1). Use *TOC water* for the final rinse of glassware.

**Solutions**

*TOC water.* Highly purified *water* complying with the following specifications:

Conductivity. Not more than 1.0  $\mu\text{S cm}^{-1}$  at 25°

TOC. Not more than 0.1 mg/l

*Test solution.* Collect carefully the water to be tested in an airtight container with minimum head space and examine it with minimum delay.

*Standard solution.* Dissolve *sucrose*, previously dried at 105° for 3 hours, in sufficient *TOC water* to produce a solution containing 1.19 mg of sucrose per litre (0.50 mg of carbon per litre).

*System suitability solution.* Dissolve 1,4-benzoquinone in sufficient *TOC water* to produce a solution containing 0.75 mg of 1,4-benzoquinone per litre (0.50 mg of carbon per litre).

**NOTE** — Use *TOC water* obtained at the same time as that used to prepare the standard solution and the system suitability solution.

*Control solutions.* Prepare suitable blank solutions or other solutions needed for establishing the base for calibration adjustments. Run the appropriate blanks for zeroing the instrument.

**System suitability.** Run successively the *TOC water*, standard solution and system suitability solution and record the responses  $r_w$ ,  $r_s$  and  $r_{ss}$ , respectively. Calculate the percentage response efficiency from the expression:

$$\frac{r_{ss} - r_w}{r_s - r_w} \times 100$$

The system is suitable if the response efficiency is not less than 85 per cent and not more than 115 per cent of the theoretical response.

**Procedure.** Run the test solution and record the response,  $r_t$ . The test solution complies with the test if  $r_t$  is not greater than  $r_s - r_w$ .

**2.4.31. Differential Scanning Calorimetry (DSC)**

Differential Scanning Calorimetry (DSC) is a thermoanalytical technique that is used to demonstrate the energy phenomena produced during heating or cooling of a substance (or a mixture of substances) and to determine the changes in enthalpy and specific heat and the temperatures at which these occur. The DSC instrument measures the heat flow in and out of both a sample and reference crucible during a controlled temperature programme. The sample crucible usually contains the substance (or a mixture of substances) under study and the reference crucible is either left empty or is loaded with an inert reference material relevant to the sample under investigation. Both the sample and reference are maintained at very nearly the same temperature throughout the experiment. Generally, the temperature program for a DSC analysis is designed such that the sample holder temperature increases linearly as a function of time. The reference sample should have a well

defined heat capacity over the range of temperatures to be scanned.

**Instrumentation.** A typical DSC instrument consists of two sealed crucibles: a sample crucible and a reference crucible (which is generally an empty sample pan). A temperature-programming device, thermal detector(s) and a recording system, which can be connected to a computer, are attached. The measurements are carried out under a controlled atmosphere. Calibration of the apparatus for temperature and enthalpy change is done using Indium or Zinc of high purity or any other suitable certified material, according to the manufacturer's instructions.

**Operating procedure.** Weigh an appropriate quantity of the substance to be examined and place in the sample crucible. Set the initial and final temperatures, and the heating rate according to the operating conditions prescribed in the monograph. Begin the analysis and record the thermogram, with the temperature and/or time on the *x-axis* and the energy change on the *y-axis*. The temperature at which the phenomenon occurs (the onset temperature) corresponds to the intersection of the extension of the baseline with the tangent at the point of greatest slope (inflexion point) of the curve (Fig 2.4.31-1). The peak of the curve indicates the end of the thermal phenomenon. The enthalpy of the phenomenon is proportional to the area under the curve limited by the baseline; the proportionality factor is determined from the measurement of the heat of fusion of a known substance (e.g., Indium) under the same operating conditions. Each thermogram may be accompanied by the following data: conditions employed, record of last calibration, sample size and identification (including thermal history), container, atmosphere (identity, flow rate, pressure), direction and rate of temperature change, instrument and recorder sensitivity.

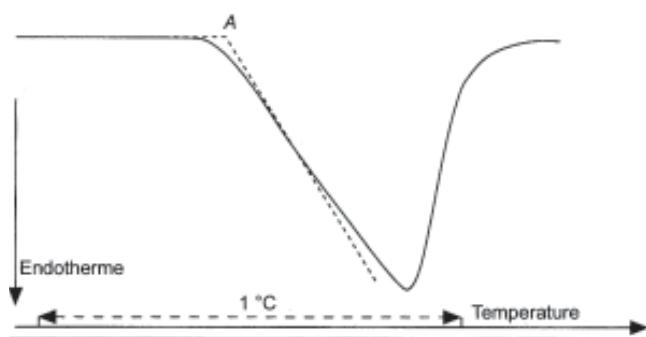

Fig.2.4.31-1 Endothermic thermogram

**Applications.** Basic principle underlying applicability of the DSC technique is that, when the sample undergoes a physical transformation such as phase transitions, more (or less) heat will need to flow to it than the reference to maintain both at the same temperature.

**Phase changes** - The typical examples of phase changes are:

- Solid - solid transition, e.g., polymorphic phase transition, glass transition, desolvation, amorphous-crystalline
- Solid - liquid transition, e.g., melting
- Solid - gas transition, e.g., sublimation
- Liquid - solid transition, e.g., freezing, recrystallisation
- Liquid - gas transition, e.g., evaporation

These changes can be demonstrated as changes in enthalpy or heat capacity as a function of temperature.

**Changes in chemical composition** - Measurement of heat and temperatures of reaction under given experimental conditions may be done using DSC, e.g., the kinetics of decomposition or the kinetics of desolvation.

**Application to phase diagrams** - Establishment of phase diagrams for solid mixtures can be achieved which is an important step in the preformulation and optimisation of the freeze-drying process.

**Determination of purity** - The measurement of the heat of fusion and the melting point by DSC enables to determine the purity content of a substance from a single thermal diagram, requiring only a few milligrams of sample with no need for repeated accurate measurements of the true temperature. The determination of the molar purity by DSC is based on the use of a mathematical approximation of the integrated form of the Van't Hoff equation applied to the concentrations (not the activities) in a binary system.

$$T = T_0 - \frac{RT_0^2}{\Delta H_f} \times x_2$$

where,  $x_2$  = mole fraction of the impurity i.e. the number of molecules of the impurity divided by the total number of molecules in the liquid phase (or molten phase) at temperature  $T$  (expressed in kelvins),

$T_0$  = melting point of the chemically pure substance, in kelvins,

$\Delta H_f$  = molar heat of fusion of the substance, in joules,

$R$  = gas constant for ideal gases, in joules-kelvin<sup>-1</sup>·mole<sup>-1</sup>.

**Detection and/or quantitation of stereoisomeric impurities** - There are substances (e.g., ethambutol hydrochloride) that show typical behaviour of polymorphic phase transformation, viz, one polymorphic form of the drug gets converted into the second form before melting point and the transformation is reversible when temperature is increased or decreased (Fig. 2.4.31-2). This kind of phenomenon is known as enantiotropic



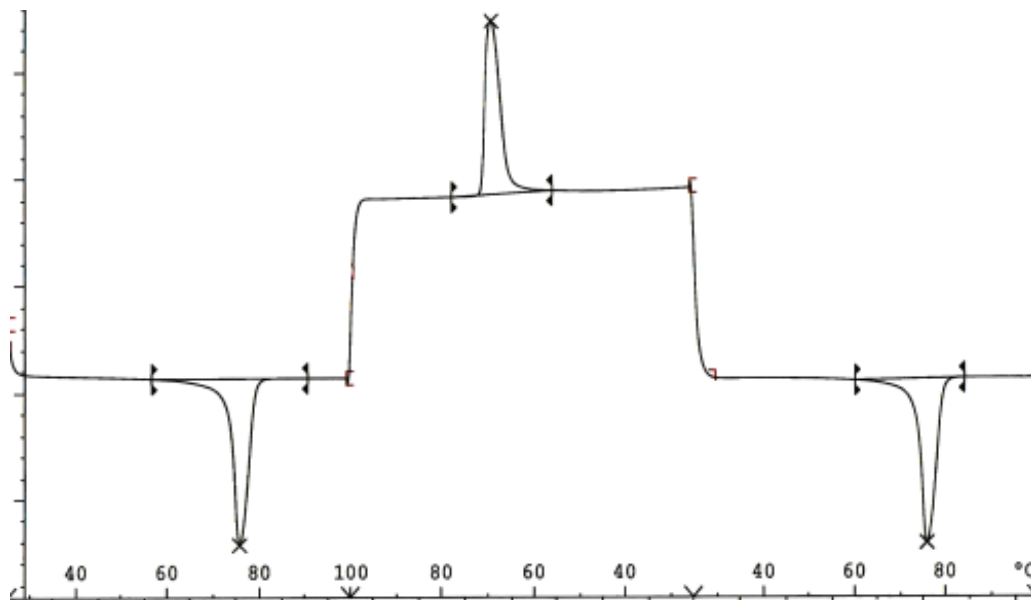

Fig. 2.4.31-2 Enantiotropic behaviour of ethambutol hydrochloride

polymorphism. This solid-state property of the substances is sometime characteristic for individual stereoisomers. Enthalpy associated with the polymorphic phase transformation for individual stereoisomers can be used in qualitative, and also quantitative applications, as the same is directly proportional to the amount of substance under investigation.

### 2.4.32. Capillary Electrophoresis

Capillary Electrophoresis is a method of analysis based on the migration, inside a capillary, of charged analytes dissolved in an electrolyte solution, under the influence of a direct-current electric field.

#### Apparatus

An apparatus for capillary electrophoresis consists of:

- a high-voltage, controllable direct-current power supply;
- buffer reservoirs, held at the same level, containing the prescribed anodic and cathodic solutions;
- electrode assemblies (the cathode and the anode), immersed in the buffer reservoirs and connected to the power supply;
- a separation capillary (usually made of fused-silica) which, when used with some specific types of detectors, has an optical viewing window aligned with the detector. The ends of the capillary are placed in the buffer reservoirs. The capillary is filled with the solution prescribed in the monograph;

- a suitable injection system;
- a detector able to monitor the amount of substances of interest passing through a segment of the separation capillary at a given time; it is usually based on absorption spectrophotometry (UV and visible) or fluorimetry, but conductimetric, amperometric or mass spectrometric detection can be useful for specific applications; indirect detection is an alternative method used to detect non-UV-absorbing and non-fluorescent compounds;
- a thermostatic system able to maintain a constant temperature inside the capillary is recommended to obtain a good separation reproducibility;
- a recorder and a suitable integrator or a computer.

The definition of the injection process and its automation are critical for precise quantitative analysis. Modes of injection include gravity, pressure or vacuum injection and electrokinetic injection. The amount of each sample component introduced electrokinetically depends on its electrophoretic mobility, leading to possible discrimination using this injection mode.

Use the capillary, the buffer solutions, the preconditioning method, the sample solution and the migration conditions prescribed in the monograph of the considered substance. The employed electrolytic solution is filtered to remove particles and degassed to avoid bubble formation that could interfere with the detection system or interrupt the electrical contact in the capillary during the separation run. A rigorous rinsing procedure should be developed for each analytical method to achieve reproducible migration times of the solutes.

### Capillary Zone Electrophoresis

In capillary zone electrophoresis, analytes are separated in a capillary containing only buffer without any anticonvective medium. With this technique, separation takes place because the different components of the sample migrate as discrete bands with different velocities. The velocity of each band depends on the electrophoretic mobility of the solute and the electro-osmotic flow in the capillary (see General Principles). Coated capillaries can be used to increase the separation capacity of those substances adsorbing on fused-silica surfaces.

Using this mode of capillary electrophoresis, the analysis of both small ( $M_r < 2000$ ) and large molecules ( $2000 < M_r < 100\,000$ ) can be accomplished. Due to the high efficiency achieved in capillary zone electrophoresis, separation of molecules having only minute differences in their charge-to-mass ratio can be effected. This separation mode also allows the separation of chiral compounds by addition of chiral selectors to the separation buffer.

#### Optimisation

Optimisation of the separation is a complex process where several separation parameters can play a major role. The main factors to be considered in the development of separations are instrumental and electrolytic solution parameters.

#### Instrumental parameters

**Voltage.** A Joule heating plot is useful in optimising the applied voltage and capillary temperature. Separation time is inversely proportional to applied voltage. However, an increase in the voltage used can cause excessive heat production, giving rise to temperature and, as a result thereof, viscosity gradients in the buffer inside the capillary. This effect causes band broadening and decreases resolution.

**Polarity.** Electrode polarity can be normal (anode at the inlet and cathode at the outlet) and the electro-osmotic flow will move toward the cathode. If the electrode polarity is reversed, the electro-osmotic flow is away from the outlet and only charged analytes with electrophoretic mobilities greater than the electro-osmotic flow will pass to the outlet.

**Temperature.** The main effect of temperature is observed on buffer viscosity and electrical conductivity, and therefore on migration velocity. In some cases, an increase in capillary temperature can cause a conformational change in proteins, modifying their migration time and the efficiency of the separation.

**Capillary.** The dimensions of the capillary (length and internal diameter) contribute to analysis time, efficiency of separations and load capacity. Increasing both effective length and total length can decrease the electric fields (working at constant voltage) which increases migration time. For a given buffer

and electric field, heat dissipation, and hence sample band-broadening, depend on the internal diameter of the capillary. The latter also affects the detection limit, depending on the sample volume injected and the detection system employed.

Since the adsorption of the sample components on the capillary wall limits efficiency, methods to avoid these interactions should be considered in the development of a separation method. In the specific case of proteins, several strategies have been devised to avoid adsorption on the capillary wall. Some of these strategies (use of extreme pH and adsorption of positively charged buffer additives) only require modification of the buffer composition to prevent protein adsorption. In other strategies, the internal wall of the capillary is coated with a polymer, covalently bonded to the silica, that prevents interaction between the proteins and the negatively charged silica surface. For this purpose, ready-to-use capillaries with coatings consisting of neutral-hydrophilic, cationic and anionic polymers are available.

#### Electrolytic solution parameters

**Buffer type and concentration.** Suitable buffers for capillary electrophoresis have an appropriate buffer capacity in the pH range of choice and low mobility to minimise current generation.

Matching buffer-ion mobility to solute mobility, whenever possible, is important for minimising band distortion. The type of sample solvent used is also important to achieve on-column sample focusing, which increases separation efficiency and improves detection.

An increase in buffer concentration (for a given pH) decreases electro-osmotic flow and solute velocity.

**Buffer pH.** The pH of the buffer can affect separation by modifying the charge of the analyte or additives, and by changing the electro-osmotic flow. In protein and peptide separation, changing the pH of the buffer from above to below the isoelectric point (pI) changes the net charge of the solute from negative to positive. An increase in the buffer pH generally increases the electro-osmotic flow.

**Organic solvents.** Organic modifiers (methanol, acetonitrile, etc.) may be added to the aqueous buffer to increase the solubility of the solute or other additives and/or to affect the degree of ionisation of the sample components. The addition of these organic modifiers to the buffer generally causes a decrease in the electro-osmotic flow.

**Additives for chiral separations.** For the separation of optical isomers, a chiral selector is added to the separation buffer. The most commonly used chiral selectors are cyclodextrins, but crown ethers, polysaccharides and proteins may also be used. Since chiral recognition is governed by the different interactions between the chiral selector and each of the

enantiomers, the resolution achieved for the chiral compounds depends largely on the type of chiral selector used. In this regard, for the development of a given separation it may be useful to test cyclodextrins having a different cavity size ( $\alpha$ -,  $\beta$ -, or  $\gamma$ -cyclodextrin) or modified cyclodextrins with neutral (methyl, ethyl, hydroxyalkyl, etc.) or ionisable (aminomethyl, carboxymethyl, sulphobutyl ether, etc.) groups. When using modified cyclodextrins, batch-to-batch variations in the degree of substitution of the cyclodextrins must be taken into account since it will influence the selectivity. Other factors controlling the resolution in chiral separations are concentration of chiral selector, composition and pH of the buffer and temperature. The use of organic additives, such as methanol or urea can also modify the resolution achieved.

### Capillary Gel Electrophoresis

In capillary gel electrophoresis, separation takes place inside a capillary filled with a gel that acts as a molecular sieve. Molecules with similar charge-to-mass ratios are separated according to molecular size since smaller molecules move more freely through the network of the gel and therefore migrate faster than larger molecules. Different biological macromolecules (for example, proteins and DNA fragments), which often have similar charge-to-mass ratios, can thus be separated according to their molecular mass by capillary gel electrophoresis.

#### *Characteristics of gels*

Two types of gels are used in capillary electrophoresis: permanently coated gels and dynamically coated gels. Permanently coated gels, such as cross-linked polyacrylamide, are prepared inside the capillary by polymerisation of the monomers. They are usually bonded to the fused-silica wall and cannot be removed without destroying the capillary. If the gels are used for protein analysis under reducing conditions, the separation buffer usually contains sodium dodecyl sulphate and the samples are denatured by heating in a mixture of sodium dodecyl sulphate and 2-mercaptoethanol or dithiothreitol before injection. When non-reducing conditions are used (for example, analysis of an intact antibody), 2-mercaptoethanol and dithiothreitol are not used. Separation in cross-linked gels can be optimised by modifying the separation buffer (as indicated in the capillary zone electrophoresis section) and controlling the gel porosity during the gel preparation. For cross-linked polyacrylamide gels, the porosity can be modified by changing the concentration of acrylamide and/or the proportion of cross-linker. As a rule, a decrease in the porosity of the gel leads to a decrease in the mobility of the solutes. Due to the rigidity of these gels, only electrokinetic injection can be used.

Dynamically coated gels are hydrophilic polymers, such as linear polyacrylamide, cellulose derivatives, dextran, etc., which

can be dissolved in aqueous separation buffers giving rise to a separation medium that also acts as a molecular sieve. These separation media are easier to prepare than cross-linked polymers. They can be prepared in a vial and filled by pressure in a wall-coated capillary (with no electro-osmotic flow). Replacing the gel before every injection generally improves the separation reproducibility. The porosity of the gels can be increased by using polymers of higher molecular mass (at a given polymer concentration) or by decreasing the polymer concentration (for a given polymer molecular mass). A reduction in the gel porosity leads to a decrease in the mobility of the solute for the same buffer. Since the dissolution of these polymers in the buffer gives low viscosity solutions, both hydrodynamic and electrokinetic injection techniques can be used.

### Capillary Isoelectric Focusing

In isoelectric focusing, the molecules migrate under the influence of the electric field, so long as they are charged, in a pH gradient generated by ampholytes having pI values in a wide range (poly-aminocarboxylic acids), dissolved in the separation buffer.

The three basic steps of isoelectric focusing are loading, focusing and mobilisation.

**Loading step.** Two methods may be employed:

- loading in one step: the sample is mixed with ampholytes and introduced into the capillary either by pressure or vacuum;
- sequential loading: a leading buffer, then the ampholytes, then the sample mixed with ampholytes, again ampholytes alone and finally the terminating buffer are introduced into the capillary. The volume of the sample must be small enough not to modify the pH gradient.

**Focusing step.** When the voltage is applied, ampholytes migrate toward the cathode or the anode, according to their net charge, thus creating a pH gradient from anode (lower pH) to cathode (higher pH). During this step the components to be separated migrate until they reach a pH corresponding to their isoelectric point (pI) and the current drops to very low values.

**Mobilisation step.** If mobilisation is required for detection, use one of the following methods.

- Mobilisation is accomplished during the focusing step under the effect of the electro-osmotic flow; the electro-osmotic flow must be small enough to allow the focusing of the components;
- Mobilisation is accomplished by applying positive pressure after the focusing step;
- Mobilisation is achieved after the focusing step by adding salts to the cathode reservoir or the anode reservoir

(depending on the direction chosen for mobilisation) in order to alter the pH in the capillary when the voltage is applied. As the pH is changed, the proteins and ampholytes are mobilised in the direction of the reservoir which contains the added salts and pass the detector.

The separation achieved, expressed as DpI, depends on the pH gradient ( $dpH/dx$ ), the number of ampholytes having different pI values, the molecular diffusion coefficient ( $D$ ), the intensity of the electric field ( $E$ ) and the variation of the electrophoretic mobility of the analyte with the pH ( $-d\mu/dpH$ ):

$$\Delta pI = 3 \times \sqrt{\frac{D(dpH/dx)}{E(-d\mu/dpH)}}$$

### Optimisation

The main parameters to be considered in the development of separations are:

**Voltage.** Capillary isoelectric focusing utilises very high electric fields, 300 V/cm to 1000 V/cm in the focusing step.

**Capillary.** The electro-osmotic flow must be reduced or suppressed depending on the mobilisation strategy (see above). Coated capillaries tend to reduce the electro-osmotic flow.

**Solutions.** The anode buffer reservoir is filled with a solution with a pH lower than the pI of the most acidic ampholyte and the cathode reservoir is filled with a solution with a pH higher than the pH of the most basic ampholyte. Phosphoric acid for the anode and sodium hydroxide for the cathode are frequently used.

Addition of a polymer, such as methylcellulose, in the ampholyte solution tends to suppress convective forces (if any) and electro-osmotic flow by increasing the viscosity. Commercial ampholytes are available covering many pH ranges and may be mixed if necessary to obtain an expanded pH range. Broad pH ranges are used to estimate the isoelectric point whereas narrower ranges are employed to improve accuracy. Calibration can be done by correlating migration time with isoelectric point for a series of protein markers.

During the focusing step precipitation of proteins at their isoelectric point can be prevented, if necessary, using buffer additives such as glycerol, surfactants, urea or zwitterionic buffers. However, depending on the concentration, urea denatures proteins.

## 2.4.33. Isoelectric Focusing

Isoelectric focusing (IEF) is a method of electrophoresis that separates proteins according to their isoelectric point. Separation is carried out in a slab of polyacrylamide or agarose

gel that contains a mixture of amphoteric electrolytes (ampholytes). When subjected to an electric field, the ampholytes migrate in the gel to create a pH gradient. In some cases gels containing an immobilised pH gradient, prepared by incorporating weak acids and bases to specific regions of the gel network during the preparation of the gel, are used. When the applied proteins reach the gel fraction that has a pH that is the same as their isoelectric point (pI), their charge is neutralised and migration ceases. Gradients can be made over various ranges of pH, according to the mixture of ampholytes chosen.

### General aspects

Special attention must be paid to sample characteristics and/or preparation. Having salt in the sample can be problematic and it is best to prepare the sample, if possible, in deionised water or 2 per cent ampholytes, using dialysis or gel filtration if necessary.

The time required for completion of focusing in thin-layer polyacrylamide gels is determined by placing a coloured protein (e.g. haemoglobin) at different positions on the gel surface and by applying the electric field: the steady state is reached when all applications give an identical band pattern. In some protocols the completion of the focusing is indicated by the time elapsed after the sample application.

The IEF gel can be used as an identity test when the migration pattern on the gel is compared to a suitable standard preparation and IEF calibration proteins, the IEF gel can be used as a limit test when the density of a band on IEF is compared subjectively with the density of bands appearing in a standard preparation, or it can be used as a quantitative test when the density is measured using a densitometer or similar instrumentation to determine the relative concentration of protein in the bands subject to validation.

### Apparatus

- a controllable generator for constant potential, current and power; potentials of 2500 V have been used and are considered optimal under a given set of operating conditions; a supply of up to 30 W of constant power is recommended; a rigid plastic IEF chamber that contains a cooled plate, of suitable material, to support the gel;
- a plastic cover with platinum electrodes that are connected to the gel by means of paper wicks of suitable width, length and thickness, impregnated with solutions of anodic and cathodic electrolytes.

### Procedure

#### Preparation of the gels

**Mould** The mould (see Figure 2.4.33-1) is composed of a glass plate (A) on which a polyester film (B) is placed to



facilitate handling of the gel, one or more spacers (C), a second glass plate (D) and clamps to hold the structure together.

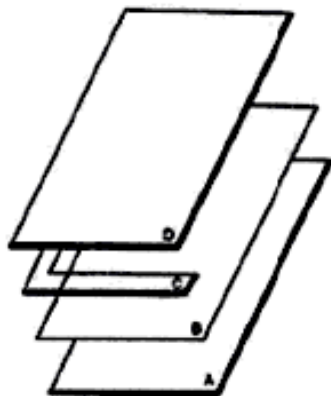

Fig. 2.4.33-1– Mould

**7.5 per cent polyacrylamide gel.** Dissolve 29.1 g of *acrylamide* and 0.9 g of *methylenebisacrylamide* in 100 ml of *water*. To 2.5 volumes of this solution, add the mixture of ampholytes specified in the monograph and dilute to 10 volumes with *water*. Mix carefully and degas the solution.

**Preparation of the mould** Place the polyester film on the lower glass plate, apply the spacer, place the second glass plate and fit the clamps. Before use, place the solution on a magnetic stirrer and add 0.25 volumes of a 100 g/l solution of *ammonium persulphate* and 0.25 volumes of *tetramethylethylenediamine*. Immediately fill the space between the glass plates of the mould with the solution.

#### Method

Dismantle the mould and, making use of the polyester film, transfer the gel onto the cooled support, wetted with a few millilitres of a suitable liquid, taking care to avoid forming air bubbles. Prepare the test solutions and reference solutions as specified in the monograph. Place strips of paper for sample application, about 10 mm × 5 mm in size, on the gel and impregnate each with the prescribed amount of the test and reference solutions. Also apply the prescribed quantity of a solution of proteins with known isoelectric points as pH markers to calibrate the gel. In some protocols the gel has pre-cast slots where a solution of the sample is applied instead of using impregnated paper strips. Cut 2 strips of paper to the length of the gel and impregnate them with the electrolyte solutions: acid for the anode and alkaline for the cathode. The compositions of the anode and cathode solutions are given in the monograph. Apply these paper wicks to each side of the gel several millimetres from the edge. Fit the cover so that the electrodes are in contact with the wicks (respecting the anodic and cathodic poles). Proceed with the isoelectric focusing by applying the electrical parameters described in the monograph.

Switch off the current when the migration of the mixture of standard proteins has stabilised. Using forceps, remove the sample application strips and the 2 electrode wicks. Immerse the gel in fixing solution for isoelectric focusing in *polyacrylamide gel*. Incubate with gentle shaking at room temperature for 30 min. Drain off the solution and add 200 ml of *destaining solution*. Incubate with shaking for 1 h. Drain the gel, add *coomassie staining solution*. Incubate for 30 min. Destain the gel by passive diffusion with *destaining solution* until the bands are well visualised against a clear background. Locate the position and intensity of the bands in the electropherogram as prescribed in the monograph.

#### Variations to the Procedure (subject to validation)

Where reference to the general method on isoelectric focusing is made, variations in methodology or procedure may be made subject to validation. These include:

- the use of commercially available pre-cast gels and of commercial staining and destaining kits,
- the use of immobilised pH gradients,
- the use of rod gels,
- the use of gel cassettes of different dimensions, including ultra-thin (0.2 mm) gels,
- variations in the sample application procedure, including different sample volumes or the
- use of sample application masks or wicks other than paper,
- the use of alternate running conditions, including variations in the electric field depending on gel dimensions and equipment, and the use of fixed migration times rather than subjective interpretation of band stability,
- the inclusion of a pre-focusing step, the use of automated instrumentation,
- the use of agarose gels.

#### Specified Variations to the General Method

Variations to the general method required for the analysis of specific substances may be specified in detail in monographs. These include:

- the addition of urea in the gel (3 M concentration is often satisfactory to keep protein in solution but up to 8 M can be used): some proteins precipitate at their isoelectric point; in this case, urea is included in the gel formulation to keep the protein in solution; if urea is used, only fresh solutions should be used to prevent carbamylation of the protein;
- the use of alternative staining methods;
- the use of gel additives such as non-ionic detergents (e.g. octylglucoside) or zwitterionic detergents (e.g., CHAPS or CHAPSO), and

- d) the addition of ampholyte to the sample, to prevent proteins from aggregating or precipitating.

**Points to Consider**

Samples can be applied to any area on the gel, but to protect the proteins from extreme pH environments samples should not be applied close to either electrode. During method development the analyst can try applying the protein in 3 positions on the gel (i.e. middle and both ends); the pattern of a protein applied at opposite ends of the gel may not be identical.

A phenomenon known as cathodic drift, where the pH gradient decays over time, may occur if a gel is focused too long. Although not well understood, electroendosmosis and absorption of carbon dioxide may be factors that lead to cathodic drift. Cathodic drift is observed as focused protein migrating off the cathode end of the gel. Immobilised pH gradients may be used to address this problem.

Efficient cooling (approximately 4°C) of the bed that the gel lies on during focusing is important. High field strengths used during isoelectric focusing can lead to overheating and affect the quality of the focused gel.

## 2.5. PHARMACEUTICAL METHODS

2.5.1. Disintegration Test	....
2.5.2. Dissolution Test	....
2.5.3. Uniformity of Weight of Single-Dose Preparations	....
2.5.4. Uniformity of Content of Single-Dose Preparations	....
2.5.5. Friability of Uncoated Tablets	....
2.5.6. Contents of Packaged Dosage Forms	....
2.5.7. Powder Fineness	....
2.5.8. Particle Size by Microscopy	....
2.5.9. Particulate Contamination	....

### 2.5.1. Disintegration Test

This test determines whether dosage forms such as tablets, capsules, boluses pessaries and suppositories disintegrate within a prescribed time when placed in a liquid medium under the prescribed experimental conditions.

For the purpose of this test, disintegration does not imply complete solution of the dosage unit or even of its active constituent. Disintegration is defined as that state in which no residue of the unit under test remains on the screen of the apparatus or, if a residue remains, it consists of fragments of disintegrated parts of tablets component parts such as insoluble coating of the tablets or of capsule shells, or of any melted fatty substance from the pessary or suppository or is a soft mass with no palpable core. If discs have been used with capsules, any residue remaining on the lower surfaces of the discs consists only of fragments of shells.

#### For tablets and capsules

##### Apparatus

The apparatus consists of a basket-rack assembly, a 1-litre beaker, a thermostatic arrangement for heating the fluid and a mechanical device for raising and lowering the basket in the immersion fluid at a constant frequency rate.

*Basket-rack assembly.* The basket-rack assembly is rigid and supports six cylindrical glass tubes,  $77.5 \pm 2.5$  mm long,

21.5 mm in internal diameter and with a wall thickness of about 2 mm (Fig. 2.5.1-1). The tubes are held vertically by two superimposed transparent plastic plates,  $90 \pm 2$  mm in diameter and  $6.75 \pm 1.75$  mm thick perforated by six holes having the same diameter as the tubes. The holes are equidistant from the centre of the plate and are equally spaced from one another. Attached to the under side of the lower plate is a woven stainless steel wire cloth with a plain square weave with  $2.0 \pm 0.2$  mm mesh apertures and with a wire diameter of  $0.615 \pm 0.045$  mm. The upper plate is covered with a stainless steel disc perforated by six holes, each about  $24 \pm 2$  mm in diameter, which fits over the tubes and holds them between the plastic plates. The holes coincide with those of the upper plastic plate and the upper open ends of the glass tubes. A suitable means is provided to suspend the basket-rack assembly from the raising and lowering device using a point on its axis.

The plates are held rigidly in position and 77.5 mm apart by vertical metal rods at the periphery and a metal rod is also fixed to the centre of the upper plate to enable the assembly to be attached to the device for raising and lowering it smoothly at a constant frequency of between 28 and 32 cycles per minute through a distance of 50 to 60 mm. The time required for the upward stroke is equal to the time required for the downward stroke, and the change in stroke direction should be smooth and not abrupt. There should be no appreciable horizontal motion or movement of the axis from the vertical.

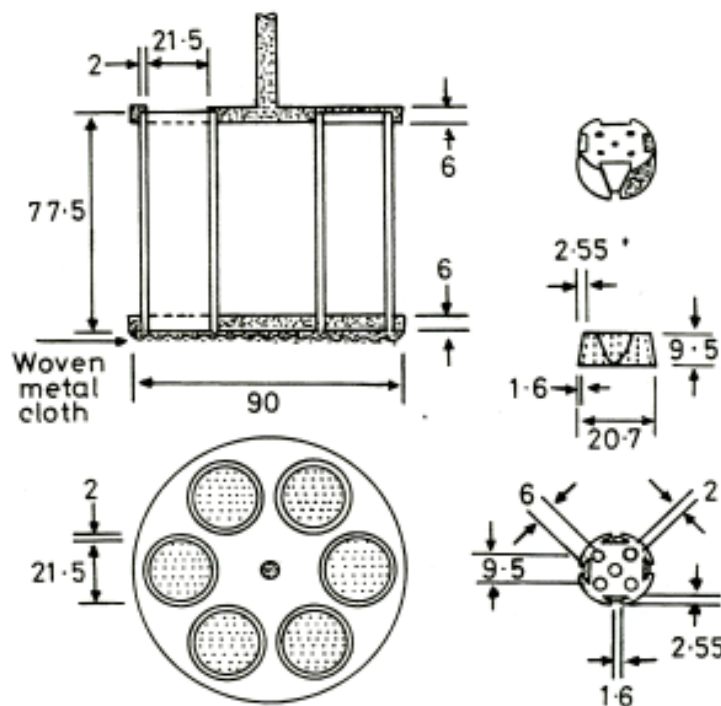

(Dimensions in mm)

Fig. 2.5.1-1: Apparatus for Disintegration of Tablets and Capsules



The design of the basket-rack assembly may be somewhat different provided specifications for the glass tubes and the screen mesh size are unchanged.

**Discs.** A cylindrical disc for each tube, each  $20.7 \pm 0.15$  mm thick in diameter and  $9.5 \pm 0.15$  mm thick, made of transparent plastic with a relative density of 1.18 to 1.20, and pierced with five holes, each 2 mm in diameter, one in the centre and the other four spaced equally on a circle of radius 6 mm from the centre of the disc. Four equally-spaced grooves are cut in the lateral surface of the disc in such a way that at the upper surface of the disc they are 9.5 mm wide and 2.55 mm deep and at the lower surface 1.6 mm square.

**Medium.** The assembly is suspended in the liquid medium in a suitable vessel, preferably a 1-litre beaker. The volume of liquid is such that the wire mesh at its highest point is at least 25 mm below the surface of the liquid, and at its lower point is at least 25 mm above the bottom of the beaker. At no time should the top of the basket-rack assembly become submerged. There is a thermostatic arrangement for heating the liquid and maintaining the temperature at  $37^\circ \pm 2^\circ$ .

**Method.** Unless otherwise stated in the individual monograph, introduce one tablet or capsule into each tube and, if directed in the appropriate general monograph, add a disc to each tube. Suspend the assembly in the beaker containing the specified liquid and operate the apparatus for the specified time. Remove the assembly from the liquid. The tablets or capsules pass the test if all of them have disintegrated.

If 1 or 2 tablets or capsules fail to disintegrate, repeat the test on 12 additional tablets or capsules; not less than 16 of the total of 18 tablets or capsules tested disintegrate.

If the tablets or capsules adhere to the disc and the preparation under examination fails to comply, repeat the test omitting the disc. The preparation complies with the test if all the tablets or capsules in the repeat test disintegrate.

#### For enteric-coated tablets

**Apparatus.** Use the apparatus for tablets and capsules described above.

**Method.** Put one tablet into each tube, suspend the assembly in the beaker containing  $0.1M$  hydrochloric acid and operate without the discs for 2 hours, unless otherwise stated in the individual monograph. Remove the assembly from the liquid. No tablet shows signs of cracks that would allow the escape of the contents or disintegration, apart from fragments of coating.

Replace the liquid in the beaker with *mixed phosphate buffer pH 6.8*, add a disc to each tube and operate the apparatus for a further 60 minutes. Remove the assembly from the liquid. If the tablet fails to comply because of adherence to the disc, repeat the test on a further 6 tablets without the discs. The tablets pass the test if all six have disintegrated.

#### For pessaries and suppositories

##### Apparatus

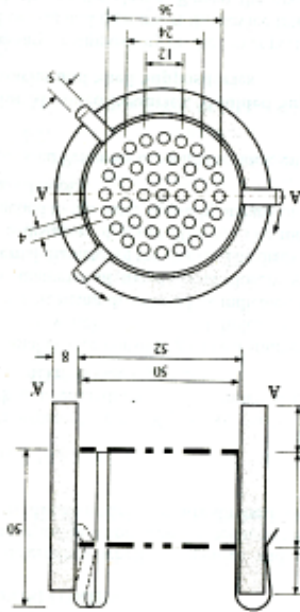

(Dimensions in mm)

Fig. 2.5.1-2a: Apparatus for Disintegration of Pessaries and Suppositories

- A transparent sleeve of glass or plastic, 60 mm high with an internal diameter of 52 mm and an appropriate wall thickness (Fig.2.5.1-2a).
- A metal device consisting of two stainless steel discs each of which contains 39 holes, each 4 mm in diameter, being distributed as indicated in Fig 2. The diameter of the disc is closely similar to the internal diameter of the sleeve. The discs are separated by a distance of about 30mm. The metal device is attached to the outer sleeve by means of three equally spaced hooks.

For Compressed Pessaries use with the hook-end downwards as in Fig. 2.5.1-2b.

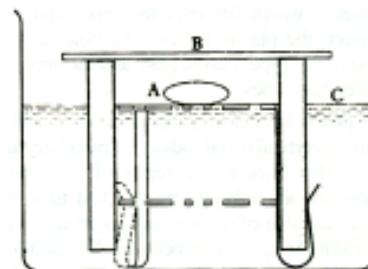

A-Compressed pessary; B-Glass Plate; C-Water surface  
Fig. 2.5.1-2b: Apparatus for Disintegration of compressed pessaries

For Moulded Pessaries, Moulded Suppositories, Shell Pessaries and Shell Suppositories

Place a pessary or suppository on the lower perforated disc of the metal device and then insert the device into the cylinder and attach this to the sleeves. Repeat the operation with a further two pessaries or suppositories and metal devices and sleeves. Unless otherwise specified, place each piece of apparatus in a vessel containing at least 4 litres of water at 36° to 37° and fitted with a slow stirrer and a means of holding the top of the apparatus 90mm below the surface of the water. A suitable thermostatic arrangement may be provided for maintaining the temperature of the bath. Alternatively, all three pieces of apparatus may be placed together in a vessel containing at least 12 litres of water. After each 10 minutes invert each apparatus without removing it from the liquid.

Disintegration is considered to be complete when the moulded pessary or suppository

- is completely dissolved or
- has dispersed into its component parts, which may remain on the surface (in the case of melted fatty substances), sink to the bottom (in case of insoluble powders) or dissolve (in case of soluble components) or may be distributed in one or more of these ways or
- has become soft with appreciable change in shape, without necessarily separating into its components, and the mass has no solid core which cannot be pressed with a glass rod.

#### *For Compressed Pessaries*

Place the apparatus in a vessel of suitable diameter containing water at 36° to 37°. Adjust the level of the liquid by the gradual addition of water at 36° to 37° until the perforations in the metal disc are just covered by a uniform layer of water. Place one compressed pessary on the upper perforated disc and cover the apparatus with a glass plate to ensure a humid atmosphere. Repeat the operation with a further two compressed pessaries.

Disintegration is considered to be complete when

- there is no residue on the perforated plate or
- if a residue remains, it consists only of a soft mass having no solid core which cannot be pressed with a glass rod.

### 2.5.2. Dissolution Test

This test is designed to determine compliance with the dissolution requirements for solid dosage forms administered orally. The test is intended for a capsule or tablet.

Use Apparatus 1 unless otherwise directed. All parts of the apparatus that may come into contact with the preparation under examination or with the dissolution medium are chemically inert and do not adsorb, react or interfere with the preparation under examination. All metal parts of the apparatus

that may come into contact with the preparation or the dissolution medium must be made from stainless steel, type 316 or equivalent or coated with a suitable material to ensure that such parts do not react or interfere with the preparation under examination or the dissolution medium.

No part of the assembly, including the environment in which the assembly is placed, contributes significant motion, agitation or vibration beyond that due to the smoothly rotating element.

An apparatus that permits observation of the preparation under examination and the stirrer during the test is preferable.

#### Apparatus 1

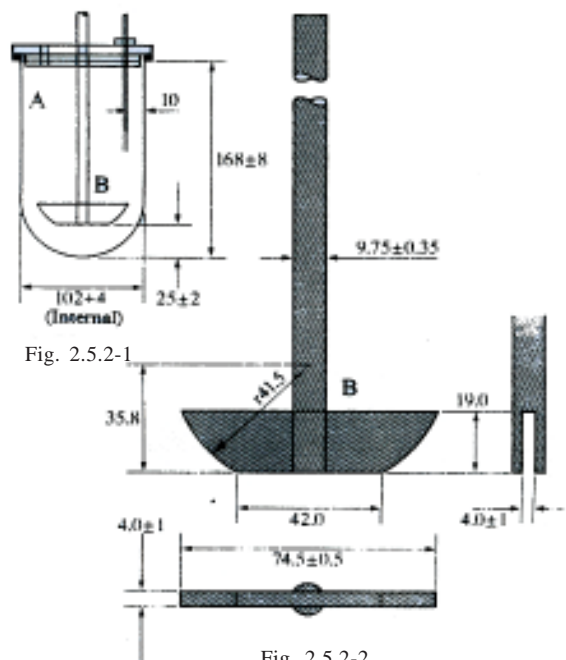

Fig. 2.5.2-1

Fig. 2.5.2-2

An assembly consisting of the following:

- A cylindrical vessel, A, made of borosilicate glass or any other suitable transparent material, with a hemispherical bottom and with a nominal capacity of 1000ml and an inside diameter of 98-106 mm (Fig.2.5.2-1). The vessel has a flanged upper rim and is fitted with a lid that has a number of openings, one of which is central.
- A motor with a speed regulator capable of maintaining the speed of rotation of the paddle within 4 per cent of that specified in the individual monograph. The motor is fitted with a stirring element which consists of a drive shaft and blade forming a paddle, B (Fig.2.5.2-2).

The blade passes through the diameter of the shaft so that the bottom of the blade is flush with the bottom of the shaft. The shaft is positioned so that its axis is within 2 mm of the axis of the vessel and the lower edge of the blade is 23 to 27 mm from the inside bottom of the vessel. The apparatus operates in

such a way that the paddle rotates smoothly and without significant wobble.

c. A water-bath set to maintain the dissolution medium at 36.5° to 37.5°. The bath liquid is kept in constant and smooth motion during the test. The vessel is securely clamped in the water-bath in such a way that the displacement vibration from other equipment, including the water circulation device, is minimised.

#### Apparatus 2

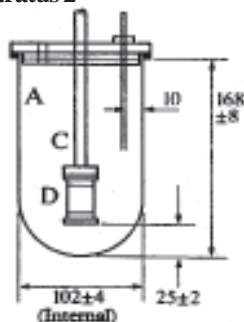

Fig. 2.5.2-3

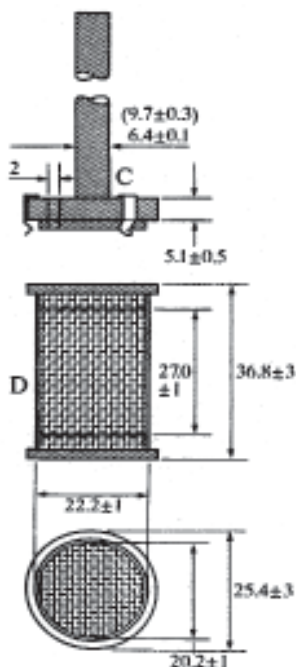

Fig. 2.5.2-4

The assembly is the same as in Apparatus 1 except that in the stirring element the paddle is replaced by a basket, D (see Figs. 2.5.2-3 and 2.5.2-4). The metallic shaft rotates smoothly and without significant wobble. The basket consists of two components. The top part, with a vent, is attached to the shaft C, it is fitted with three spring clips, or other suitable means, that allow removal of the lower part for introduction of the preparation under examination and that firmly hold the lower part of the basket concentric with the axis of the vessel during rotation. The lower detachable part of the basket is made of welded-steam cloth, with a wire thickness of 0.254 mm diameter and with 0.381 mm square openings, formed into a cylinder with narrow rim of sheet metal around the top and the bottom. The basket may be plated with a 2.5 μm layer of gold for use with acidic media. The distance between the inside bottom of the vessel and the basket is maintained at 23 to 27 mm during the test.

**Dissolution medium.** Use the dissolution medium specified in the individual monograph. If the medium is a buffered solution, adjust the solution so that its pH is within 0.05 units of the pH specified in the monograph. The dissolution medium should be deaerated prior to testing.

**Time.** Where a single time specification is given in the monograph, the test may be concluded in a shorter period if the requirement for the minimum amount dissolved is met. If two or more times are specified, specimen are to be withdrawn only at the stated times, within a tolerance of  $\pm 2$  per cent.

#### Method

##### *Conventional and prolonged-release solid dosage forms*

Place the stated volume of the dissolution medium, free from dissolved air, into the vessel of the apparatus. Assemble the apparatus and warm the dissolution medium to 36.5° to 37.5°. Unless otherwise stated, place one dosage unit in the apparatus, taking care to exclude air bubbles from the surface of the dosage unit. When Apparatus 1 is used, allow the tablet or capsule to sink to the bottom of the vessel prior to the rotation of the paddle. A suitable device such as a wire of glass helix may be used to keep horizontal at the bottom of the vessel tablets or capsules that would otherwise float.

When Apparatus 2 is used, place the tablet or capsule in a dry basket at the beginning of each test. Lower the basket into position before rotation. Operate the apparatus immediately at the speed of rotation specified in the individual monograph. Within the time interval specified, or at each of the times stated, withdraw a specimen from a zone midway between the surface of the dissolution medium and the top of the rotating blade or basket, not less than 10 mm from the wall of the vessel. Except in the case of single sampling, add a volume of dissolution medium equal to the volume of the samples withdrawn. Perform the analysis as directed in the individual monograph. Repeat the whole operation five times. Where two or more tablets or capsules are directed to be placed together in the apparatus, carry out six replicate tests.

For each of the tablet or capsule tested, calculate the amount of dissolved active ingredient in solution as a percentage of the stated amount where two or more tablets or capsules are placed together, determine for each test the amount of active ingredient in solution per tablet or capsules and calculate as a percentage of the stated amount.

#### Acceptance criteria

##### *Conventional-release dosage forms*

Unless otherwise specified, the requirements are met if the quantities of active substance dissolved from the dosage units conform to Table 1. If the results do not conform to the requirements at stage  $S_1$  given in the table, continue testing with additional dosage units through stages  $S_2$  and  $S_3$  unless the results conform at stage  $S_2$ .

Where capsule shells interfere with the analysis, remove the contents of not less than 6 capsules as completely as possible, and dissolve the empty capsule shells in the specified volume

of the dissolution medium. Perform the analysis as directed in the individual monograph. Make any necessary correction.

Correction factors should not be greater than 25 per cent of the stated amount.

Table 1

Level	Number tested	Acceptance criteria
S <sub>1</sub>	6	Each unit is not less than D* + 5 per cent**.
S <sub>2</sub>	6	Average of 12 units (S <sub>1</sub> +S <sub>2</sub> ) is equal to or greater than D, and no unit is less than D – 15 per cent**.
S <sub>3</sub>	12	Average of 24 units (S <sub>1</sub> +S <sub>2</sub> +S <sub>3</sub> ) is equal to or greater than D, not more than 2 units are less than D – 15 per cent** and no unit is less than D – 25 per cent**.

\*D is the amount of dissolved active ingredient specified in the individual monograph, expressed as a percentage of the labelled content.

\*\*Percentages of the labelled content.

Table 2

Level	Number tested	Acceptance criteria
L <sub>1</sub>	6	No individual value lies outside each of the stated ranges and no individual value is less than the stated amount at the final test time.
L <sub>2</sub>	6	The average value of the 12 units (L <sub>1</sub> + L <sub>2</sub> ) lies within each of the stated ranges and is not less than the stated amount at the final test time; none is more than 10 per cent of labelled content outside each of the stated ranges; and none is more than 10 per cent of labelled amount below the stated amount at the final test time.
L <sub>3</sub>	12	The average value of the 24 units (L <sub>1</sub> + L <sub>2</sub> + L <sub>3</sub> ) lies within each of the stated ranges, and is not less than the stated amount at the final test time; not more than 2 of the 24 units are more than 10 per cent of labelled content outside each of the stated ranges; not more than 2 of the 24 units are more than 10 per cent of labelled content below the stated amount at the final test time; and none of the units is more than 20 per cent of labelled content outside each of the stated ranges or more than 20 per cent of labelled content below the stated amount at the final test time

### **Prolonged-release dosage forms**

Unless otherwise specified, the requirements are met if the quantities of active substance dissolved from the dosage units conform to Table 2. If the results do not conform to the requirements at stage L<sub>1</sub> given in the table, continue testing with additional dosage units through stages L<sub>2</sub> and L<sub>3</sub> unless the results conform at stage L<sub>2</sub>. The limits embrace each value of D, the amount dissolved at each specified dosing interval. Where more than one range is specified, the acceptance criteria apply to each range.

*Modified-release dosage forms.* Use method A or Method B.

#### **Method A**

*Acid stage.* Place 750 ml of 0.1M hydrochloric acid in the vessel, and assemble the apparatus. Warm the dissolution medium to 36.5° to 37.5°. Place one dosage unit in the apparatus, cover the vessel and operate the apparatus at the specified rate. After 2 hours of operation in the acid medium, withdraw an aliquot of the liquid and proceed immediately as directed under Buffer stage. Perform the analysis of the aliquot using a suitable assay method.

*Buffer stage.* Complete the operations of adding the buffer and adjusting the pH within 5 minutes. With the apparatus operating at the rate specified, add to the medium in the vessel 250 ml of a 0.2 M solution of trisodium phosphate dodecahydrate that has been warmed to 36.5° to 37.5°. Adjust, if necessary, with 2M hydrochloric acid or 2M sodium hydroxide to a pH of 6.8 ± 0.05. 2M hydrochloric acid or 2M sodium hydroxide to a pH of 6.8 ± 0.05.

#### **Method B**

*Acid stage.* Place 1000 ml of 0.1M hydrochloric acid in the vessel and assemble the apparatus. Warm the dissolution medium to 36.5° to 37.5°. Place one dosage unit in the apparatus, cover the vessel and operate the apparatus at the specified rate. After 2 hours of operation in the acid medium, withdraw an aliquot of the liquid and proceed immediately as directed under Buffer stage. Perform the analysis of the aliquot using a suitable assay method.

*Buffer stage.* Use buffer that has previously been warmed to 36.5° to 37.5°. Drain the acid from the vessel and add 1000 ml of pH 6.8 phosphate buffer, prepared by mixing 3 volumes of 0.1M hydrochloric acid with 1 volume of 0.2 M solution of trisodium phosphate dodecahydrate and adjusting, if necessary, with 2M hydrochloric acid or 2M sodium hydroxide to a pH of 6.8 ± 0.05. This may also be done by removing from the apparatus the vessel containing the acid and replacing it with another vessel containing the buffer and transferring the dosage unit to the vessel containing the buffer. Continue to operate the apparatus for 45 minutes, or for the



specified time. At the end of this period, withdraw an aliquot of the liquid and perform the analysis using a suitable assay method.

#### Acceptance criteria

*Acid stage.* Unless otherwise specified, the requirements of this part of the test are met if the quantities, based on the percentage of the labelled content of active substance dissolved from the units tested conform to Table 3. Continue the testing through the 3 levels unless the results of both acid and buffer stages conform at an earlier level.

Table 3

Level	Number tested	Acceptance criteria
A <sub>1</sub>	6	No individual value exceeds 10 per cent dissolved.
A <sub>2</sub>	6	The average value of the 12 units (A <sub>1</sub> + A <sub>2</sub> ) is not more than 10 per cent dissolved, and no individual unit is greater than 25 per cent dissolved.
A <sub>3</sub>	12	The average value of the 24 units (A <sub>1</sub> + A <sub>2</sub> + A <sub>3</sub> ) is not more than 10 per cent dissolved, and no individual unit is greater than 25 per cent dissolved.

*Buffer stage.* Unless otherwise specified, the requirements of this part of the test are met if the quantities, based on the percentage of the labelled content of active substance dissolved from the units tested conform to Table 4. Continue the testing through the 3 levels unless the results of both acid and buffer stages conform at an earlier level. The value of D in Table 4 is 75 per cent dissolved unless otherwise specified. The quantity, D, is the specified total amount of active substance dissolved in both the acid and buffer stages, expressed as a percentage of the labelled content.

Table 4

Level	Number tested	Acceptance criteria
B <sub>1</sub>	6	No unit is less than D + 5 per cent*
B <sub>2</sub>	6	The average value of the 12 units (B <sub>1</sub> + B <sub>2</sub> ) is equal to or greater than D, and no unit is less than D – 15 per cent*.
B <sub>3</sub>	12	The average value of 24 units (B <sub>1</sub> + B <sub>2</sub> + B <sub>3</sub> ) is equal to or greater than D, not more than 2 units are less than D – 15 per cent*, and no unit is less than D – 25 per cent*.

\* percentages of the labelled content.

### 2.5.3. Uniformity of Weight of Single-Dose Preparations

Weigh individually 20 units selected at random or, for single-dose preparations in individual containers, the contents of 20 units, and calculate the average weight. Not more than two of the individual weights deviate from the average weight by more than the percentage shown in the table and none deviates by more than twice that percentage.

Table

Dosage form	Average weight	Percentage deviation
Uncoated and film-coated tablets	80 mg or less	10
	More than 80 mg but less than 250 mg	7.5
	250 mg or more	5
Capsules, granules and powders (single-dose)	Less than 300 mg	10
	300 mg or more	7.5
Powders for parenteral use*	More than 40 mg	10
Pessaries and suppositories	All weights	5

*For capsules.* Weigh an intact capsule. Open it without losing any part of the shell and remove the contents as completely as possible. For soft gelatin capsules, wash the shell with a suitable solvent and keep aside until the odour of the solvent is not perceptible. Weigh the shell. The difference between the weighings gives the weight of the contents. Repeat the procedure with another 19 capsules.

*For powders for parenteral use.* Remove any adhering labels from a container and wash and dry the outside. Open the container and immediately weigh it along with the contents. Empty it as completely as possible by gentle tapping, rinse it with *water* and then with *ethanol*. Dry at 100° to 105° for one hour, or if the nature of the contents does not permit drying at this temperature, dry at a lower temperature to constant weight. Cool in a desiccator and weigh. The difference in the weighings gives the weight of the contents of the container. Repeat the procedure with another 19 containers.

### 2.5.4. Uniformity of Content of Single-Dose Preparations

The test for uniformity of content of single-dose preparations is based on the assay of the individual contents of active substance(s) of a number of single-dose units to determine whether the individual contents are within limits set with reference to the average content of the sample.

*Method.* Determine the content of active ingredient(s) in each of 10 dosage units taken at random using the method given in the monograph or by any other suitable analytical method.

#### Acceptance limits

*For tablets, powders and suspensions for injection and ophthalmic inserts:*

The preparation complies with the test if each individual content is 85 to 115 per cent of the average content. The preparation fails to comply with the test if more than one individual content is outside these limits or if one individual content is outside the limits of 75 to 125 per cent of the average content.

If one individual content is outside the limits of 85 to 115 per cent of the average content but within the limits of 75 to 125 per cent, repeat the determination using another 20 dosage units. The preparation complies with the test if not more than one of the individual contents of the total sample of 30 dosage units is outside 85 to 115 per cent of the average content and none is outside the limits of 75 to 125 per cent of the average content.

For capsules, powders other than for parenteral use, granules, pessaries and suppositories:

The preparation complies with the test if not more than one individual content is outside the limits of 85 to 115 per cent of the average content and none is outside the limits of 75 to 125 per cent of the average content. The preparation fails to comply with the test if more than three individual contents are outside the limits of 85 to 115 per cent of the average content or if one or more individual contents are outside the limits of 75 to 125 per cent of the average content.

If two or three individual contents are outside the limits of 85 to 115 per cent of the average content but within the limits of 75 to 125 per cent, repeat the determination using another 20 dosage units. The preparation complies with the test if not more than three individual contents of the total sample of 30 dosage units are outside the limits of 85 to 115 per cent of the average content and none is outside the limits of 75 to 125 per cent of the average content.

### 2.5.5. Friability of Uncoated Tablets

This test is applicable to compressed tablets and is intended to determine the physical strength of tablets.

*Apparatus.* It consists of a drum of transparent synthetic polymer with polished internal surfaces and subject to minimum static build-up. It has a diameter of 283-291 mm and a depth of 36-40 mm (see figure); one side of the drum is removable. A curved projection with an inner radius of 75.5 mm to 85.5 mm and extending from the middle of the drum to the outer wall enables the tumbling of the tablets at each turn

of the drum. The outer diameter of the central ring is 24.5 mm to 25.5 mm. The drum is attached to the horizontal axis of a device that rotates at  $25 \pm 1$  rpm. It should be ensured that with every turn of the drum the tablets roll or slide and fall onto the drum wall or onto each other.

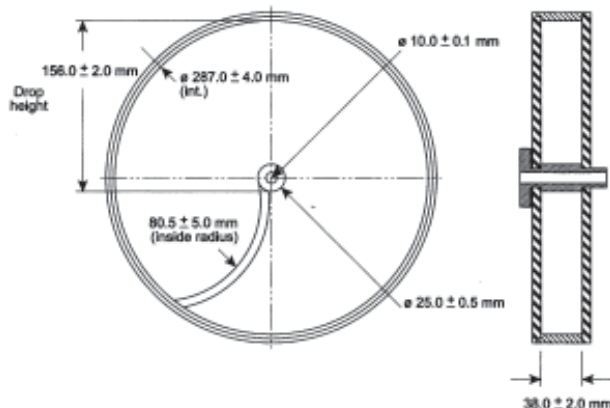

Fig. 2.5.5: Tablet friability apparatus

*Method.* For tablets with an average weight of 0.65 g or less take a sample of whole tablets corresponding to about 6.5 g and for tablets with an average weight of more than 0.65 g take a sample of 10 whole tablets.

Deduct the tablets carefully and weigh accurately the required number of tablets. Place the tablets in the drum and rotate it 100 times. Remove the tablets, remove any loose dust from them and weigh them accurately. The test is run only once unless the results are difficult to interpret or if the weight loss is greater than the targeted value, in which case, the test is repeated twice and the mean of the three tests is determined. A maximum loss of weight (from a single test or from the mean of the three tests) not greater than 1.0 per cent is acceptable for most tablets.

If obviously cracked, chipped or broken tablets are present in the sample after tumbling, the sample fails the test.

If the size or shape of the tablet causes irregular tumbling, adjust the drum base so that it forms an angle of about  $10^\circ$  with the horizontal and the tablets do not bind together when lying next to each other, which prevents them from falling freely.

### 2.5.6. Contents of Packaged Dosage Forms

The following tests and specifications apply to oral dosage forms and preparations intended for topical use that are packaged in containers in which the labelled net quantity is not more than 100 g or 300 ml or 1000 units, as the case may be. For higher labelled quantities the test and limits given in the standards of Weights and Measures (Packaged commodities) Rules, 1977 may be followed.

**Ointments, Creams, Pastes, Granules and Powders for Oral Liquids.** Select a sample of 10 filled containers and remove any labelling that might be altered in weight while removing the contents of the containers. Clean and dry the outer surfaces of the containers and weigh each container. Remove quantitatively the contents from each container. If necessary, cut open the container and wash each empty container with a suitable solvent, taking care to ensure that the closure and other parts of the container are retained. Dry and again weigh each empty container together with its parts which may have been removed. The difference between the two weights is the net weight of the contents of the container.

The average net weight of the contents of the 10 containers is not less than the labelled amount and the net weight of the contents of any single containers is not less than 91 per cent and not more than 109 per cent of the labelled amount where the labelled amount is 50 g or less, or not less than 95.5 per cent and not more than 104.5 per cent of the labelled amount where the labelled is more than 50 g but not more than 100g.

If this requirement is not met, determine the net weight of the contents of 10 additional containers. The average net weight of the contents of the 20 containers is not less than the labelled amount, and the net weight of the contents of not more than 1 of the 20 containers is less than 91 per cent or more than 109 per cent of the labelled amount where the labelled amount is 50 g or less or more than 104.5 per cent of the labelled amount is more than 50 g but not more than 100 g.

#### **Liquids and suspensions**

*Viscous preparations-* Select a sample of 10 filled containers and determine the weight of the contents of each container as directed under Ointments, Creams, Pastes, Granules and Powders for Oral Liquids. Determine the weight per ml (2.4.20) and calculate the net volume of the contents of each container.

*Non-viscous and free-flowing liquids-* Pour completely the contents of each container into calibrated volume measures of the appropriate size and determine the volume of the contents of the 10 containers.

The average net volume of the contents of the 10 containers is not less than the labelled amount, and the net volume of the contents of any single containers is not less than 91 per cent and not more than 109 per cent of the labelled amount where the labelled amount is 50 ml or less, or not less than 95.5 per cent and not more than 104.5 per cent of the labelled amount where the labelled amount is more than 50 ml but not more than 200 ml, or not less than 97 per cent but not more than 103 per cent of the labelled amount where the labelled amount is more than 200 ml but not more than 300 ml

If this requirement is not met, determine the net volume of the contents of 10 additional containers. The average net volume

of the contents of the 20 containers is not less than the labelled amount, and the net volume of the contents of not more than 1 of the 20 containers is less than 91 per cent or more than 109 per cent of the labelled amount where the labelled amount is 50 ml or less or less than 95.5 per cent or more than 104.5 per cent of the labelled amount where the labelled amount is more than 50 ml but not more than 200 ml or less than 97 per cent or more than 103 per cent of the labelled amount where the labelled amount is more than 200 ml but not more than 300 ml.

**Capsules, Pessaries, Suppositories and Tablets.** Select a sample of 10 containers and count the number of capsules, pessaries, suppositories or tablets in each container. The average number of the contents in the 10 containers is not less than the labelled amount and the number in any single container is not less than 98 per cent and not more than 102 per cent of the labelled amount.

If this requirements is not met, count the number of the contents in 10 additional containers. The average number in the 20 containers is not less than the labelled amount, and the number in not more than 1 of the 20 containers is less than 98 per cent or more than 102 per cent of the labelled amount.

### **2.5.7. Powder Fineness**

The degree of coarseness or fineness of a powder is expressed by reference to the nominal mesh aperture size of the sieves used for measuring the size of the powders. For practical reasons, the use of sieves (2.1.3) for measuring powder fineness for most pharmaceutical purposes, is convenient but devices other than sieves must be employed for the measurement of particles less than 100  $\mu\text{m}$  in nominal size. Fineness of the powder may be expressed as a percentage w/w passing the sieve(s) used or in the following descriptive terms.

The following terms are used in the description of powders.

**Coarse powder.** A powder all the particles of which pass through a sieve with a nominal mesh aperture of 1700  $\mu\text{m}$  and not more than 40 per cent by weight through a sieve with a nominal mesh aperture of 355  $\mu\text{m}$ .

**Moderately coarse powder.** A powder all the particles of which pass through a sieve with nominal mesh aperture of 710  $\mu\text{m}$  and not more than 40 per cent by weight through a sieve with a nominal mesh aperture of 250  $\mu\text{m}$ .

**Moderately fine powder.** A powder all the particles of which pass through a sieve with a nominal mesh aperture of 355  $\mu\text{m}$  and not more than 40 per cent by weight through a sieve with a nominal mesh aperture of 180  $\mu\text{m}$ .

**Fine powder.** A powder all the particles of which pass through a sieve with nominal mesh aperture of 180  $\mu\text{m}$  and not more

than 40 per cent by weight pass through a sieve with a nominal mesh aperture of 125  $\mu\text{m}$ .

**Very fine powder.** A powder all the particles of which pass through a sieve with a nominal mesh aperture of 125  $\mu\text{m}$  and not more than 40 per cent by weight pass through a sieve with a nominal mesh aperture of 45  $\mu\text{m}$ .

**Microfine powder.** A powder of which not less than 90 per cent by weight of the particles pass through a sieve with a nominal mesh aperture of 45  $\mu\text{m}$ .

**Superfine powder.** A powder of which not less than 90 per cent by number of the particles are less than 10  $\mu\text{m}$  in size.

When the fineness of the powder is described by means of a number, it is intended that all the particles of the powder shall pass through a sieve of which the nominal mesh aperture, in  $\mu\text{m}$ , is equal to that number.

When a batch of a vegetable drug is being ground and sifted, no portion of the drug shall be rejected, but it is permissible, except in the case of assays, to withhold the final tailings, if an approximately equal amount of tailings from a preceding batch of the same drug has been added before grinding.

### Sieves

Sieves for testing powder fineness comply with the requirements stated under sieves (2.1.3).

### Method

**For coarse and moderately coarse powders.** Place 25 to 100 g of the powder under examination upon the appropriate sieve having a close-fitting receiving pan and cover. Shake the sieve in a rotary horizontal direction and vertically by tapping on a hard surface for not less 20 minutes or until shifting is practically complete. Weigh accurately the amount remaining on the sieve and in the receiving pan.

**For fine and very fine powders.** Proceed as described under Coarse and moderately coarse powders except that (a) the test sample should not exceed 25 g, (b) the sieve is to be shaken for not less than 30 minutes or until sifting is practically complete, and (c) the particles passing through a sieve of nominal mesh aperture of 45  $\mu\text{m}$  are determined by suitable microscopic examination.

**For microfine and superfine powders.** Proceed as described under Fine and very fine powders except that the particles passing through a sieve of nominal mesh aperture of 45  $\mu\text{m}$  (for fine powders.) or those less than 10  $\mu\text{m}$  in size are determined by suitable microscopic examination.

With oily and other powders which tend to clog the openings, carefully brush the screen at intervals during sifting. Break up any lump that may form. A mechanical sieve shaker which reproduces the circular and tapping motion given to sieves in

hand sifting but has a uniform mechanical action may be employed.

*NOTE — Avoid prolonged shaking that would result in increasing the fineness of the powder during the testing.*

## 2.5.8. Particle Size by Microscopy

This method is suitable for counting and characterising particles of 1  $\mu\text{m}$  and greater. With increased resolving power of the microscope particles smaller than 1  $\mu\text{m}$  can be detected and characterised. Although alternative techniques are available the method is particularly useful for characterising particles that are not spherical.

**Apparatus.** A microscope with sufficient magnification to allow adequate characterisation of the smallest particles to be classified in the sample under examination, polarising filters in conjunction with analysers and retardation plates, and colour filters of relatively narrow spectral transmission for photomicrography. Condensers, corrected for spherical aberration are required in the microscope substage and with the lamp. The lamp should provide uniform and adjustable intensity of light over the entire field of view. The numerical aperture of the substage condenser should match that of the objective under the conditions of use.

All the elements of the optical system should be aligned and focussed in accordance with the recommendations of the equipment manufacturer. Critical axial alignment is essential.

Before use, it must be ensured that the microscope is stable and is placed on a surface protected from vibration.

**Visual characterisation.** The magnification and numerical aperture must be sufficiently high to allow adequate resolution of the images of the particles. The actual magnification should be determined using a calibrated stage micrometer to calibrate an ocular micrometer. If the magnification is such that the image of the particle is at least 10 ocular divisions, errors can be minimised. Each objective should be calibrated separately. To calibrate the ocular scale, the stage micrometer and the ocular scale should be aligned in order to enable a precise determination of the distance between ocular stage divisions. The use of different magnifications may be necessary to characterise materials of varying particle size in a sample.

**Photographic characterisation.** It must be ensured that the object is sharply focussed at the plane of the photographic emulsion. The actual magnification may be determined by photographing a calibrated stage micrometer, using photographic film of the right speed, resolving power and contrast. Exposure and processing must be identical for the photographs of both the test sample and the determination of magnification.



**Limit test of particle size.** Weigh a suitable quantity of the powder under examination (10-100 mg) and suspend it in 10 ml of a suitable medium in which sufficient contrast between the sample and the medium is obtained to ensure adequate detail of the sample edge. The medium should be such that the powder will not dissolve in it. Add, if necessary, a wetting agent in order to obtain a homogeneous suspension and provide adequate agitation to achieve uniform distribution of the powder. Introduce a portion of the homogeneous suspension into a suitable mounting cell. It must be ensured that the particles rest in one plane and are adequately dispersed to distinguish individual particles of interest. It is very important that the particles on the mount are representative of the distribution of sizes in the material and have not been altered during preparation of the mount.

Scan under a microscope an area corresponding to not less than 10  $\mu\text{g}$  of the powder. Count all the particles having a maximum dimension greater than the prescribed size limit.

**Particle size characterisation.** Determine the size of the sample, measure the particle sizes and analyse the data as detailed in International Standard ISO 9276. For spherical particles define the size by diameter and for irregular particles, by the definitions of the different types of diameter stated in the Standard.

**Particle shape characterisation.** This may be done for irregularly shaped particles. The homogeneity of the powder must be checked using appropriate magnification. Commonly used descriptions of shape are:

- *acicular*: slender, needle-like particle of similar width and thickness,
- *columnar*: long, thin particle with a width and thickness that are greater than those of an acicular particle,
- *equant*: particle of similar length, width, and thickness; both cubical and spherical particles are included,
- *flake*: thin, flat particle of similar length and width,
- *lath*: long, thin blade-like particle,
- *plate*: flat particle of similar length and width but with greater thickness than a flake particle.

**Crystallinity characterisation.** Unless otherwise specified in the individual monograph, mount a few particles of the sample in mineral oil on a clean glass slide. Examine the mixture using a polarising microscope; the particles should show birefringence (interference colours) and extinction positions when the microscope stage is revolved.

## 2.5.9. Particulate Contamination

For the purpose of this test, particulate contamination is defined as the unintentional presence in injections and

infusions, of extraneous, mobile, undissolved substances, other than gas bubbles.

Parenteral preparations including solutions constituted from sterile solids are expected to be free from particles of approximately 50  $\mu\text{m}$  or more that can be observed by inspection with the unaided eye. However, parenteral preparations in containers that are labelled as containing 100 ml or more of a single-dose large volume injection intended for administration by intravenous infusion should comply with the limits of sub-visible particles prescribed in this test.

The test does not apply to multiple dose injections, to single-dose small volume parenteral preparations and to parenteral solutions constituted from sterile solids. For these preparations the following method of visual assessment is adequate.

### *For visible particles*

*Apparatus.* A viewing station comprising:

- a matt black panel of suitable size kept in a vertical position,
- a non-glare white panel of the same size kept next to the black panel, and
- an adjustable lamp holder fitted with a light diffuser (such as two 13W fluorescent tubes, each about 52.5 cm in length); the intensity of illumination is kept at 2000 to 3750 lux, or higher for plastic and coloured glass containers.

*Method.* Remove any labels on the container, wash and dry the outside. Gently invert the container or swirl it, ensuring that air bubbles are not formed, and observe for about 5 seconds in front of the white panel. Repeat the procedure in front of the black panel. Note the presence of any particles.

### *For sub-visible particles*

Two methods are specified, one involving the counting of particles viewed under a microscope and the other based on the count of particles causing light obscuration. Both methods are applied on small samples. It should be noted that the results obtained in examination of a single unit or group of units cannot be extrapolated with certainty to other units that have not been sampled or tested. Therefore statistically sound sampling plans based upon a known set of given operational factors must be developed if valid inferences are to be drawn from the observed data to know the level of particulate contamination in a large group of units (such as a production batch).

#### **Method 1. Microscopic particle count test**

This method is suitable for revealing the presence of particles the longest axis or effective linear dimension of which is 10  $\mu\text{m}$  or more.

*Apparatus.* A suitable binocular microscope, filter assembly and membrane filter for retention of particles.

The microscope is equipped with an ocular micrometer calibrated with an objective micrometer, a mechanical stage that can traverse the entire filtration area of the membrane filter, an internal illuminator for providing episcopic brightfield illumination and an external focusable auxiliary illuminator for oblique illumination at an angle of 10° to 20°, and is adjusted to 100 ± 10 magnifications.

The eyepiece micrometer is a circular diameter graticule consisting of a large circle (field of view) divided by crosshairs into quadrants, transparent and black reference circles 10 µm and 25 µm in diameter at 100 magnifications, and a linear scale graduated in 10 µm increments. It should be calibrated using a standard stage micrometer grid.

The filter assembly consists of a filter holder of glass or metal and is connected to a vacuum source and a suitable membrane filter. The filter is black or dark grey in colour, is gridded or non-gridded and has a pore size of 1.0 µm or less.

*Precautions during testing.* It is important that the test is carried out under conditions that prevent the introduction of extraneous particulate contamination. The procedures should be done in a laminar air-flow cabinet or hood (of the horizontal type), equipped with HEPA (high efficiency particulate air) filters, preferably in a controlled-air environment.

Prior to carrying out the test the cabinet should be cleaned with an appropriate solvent. The glassware and filter assembly used, except for the membrane filter, should be washed carefully with a warm detergent solution and then rinsed with plenty of water. Immediately before use, both sides of the membrane filter and the equipment should be rinsed with *particle-free water*. The efficacy of these measures and the suitability of the environment should be checked by carrying out the following test.

Determine the particulate contamination of a 50-ml volume of *particle-free water* as described below. If more than 20 particles 10 µm or larger in size or if more than 5 particles 25 µm or larger in size are present within the filtration area the preparatory steps taken must be repeated until the right conditions for testing are achieved.

*Method.* Invert the container of the preparation under examination 20 times successively in order to mix the contents. Wash the outer surface of the container with a jet of *particle-free water* and remove the closure carefully, avoiding contamination of the contents.

For large-volume parenterals, single units should be tested. For small-volume parenterals less than 25 ml in volume, the contents of 10 or more units should be combined in a clean container. Where the volume of liquid in a container is very

small, the test solution may be prepared by mixing the contents of a suitable number of containers and diluting to 25 ml with *particle-free water*. Small-volume parenterals having a volume of 25 ml or more may be tested individually.

Powders for parenteral use should be constituted with *particle-free water*.

In general, the number of test samples must be adequate to provide a statistically sound assessment of the particulate contamination.

Using flat-ended forceps, carefully remove a colour contrast grid membrane filter from its container. Wash both sides of the membrane with a stream of particle-free water, starting at the top of the non-gridded side (unprinted), sweeping the stream back and forth across the surface and working slowly from top to bottom; repeat the process on the gridded side. Place the membrane with the grid side up on the filter base and install the filtering funnel on the base without sliding the funnel over the membrane filter. Invert the assembled unit and wash the inside of the funnel for about 10 seconds with a jet of *particle-free water*. Allow the water to drain and place the unit on the filter flask.

Transfer to the filtration funnel the total volume of the pooled solution or of a single unit, allow to stand for a minute, apply the vacuum and filter. If necessary, the transfer may be done in portions until the entire volume is filtered. After the last addition of solution, start rinsing the inner walls of the filter holder with a jet of *particle-free water*. Direct the jet of water in such a manner as to wash the walls of the funnel free from any particles that may have become lodged on the walls but avoid directing the stream onto the filter surface. Maintain the vacuum until the surface of the membrane filter is free from liquid. Remove the membrane filter with flat-ended forceps, place it with the gridded surface up in a Petri dish or slide and allow it to dry in air with the cover slightly ajar. After the filter has been dried, place the dish on the stage of the microscope, scan the entire membrane filter under reflected light. Count the number of particles that are equal to or greater than 10 µm, the number of particles equal to or greater than 25 µm and the particles equal to or greater than 50 µm.

Sizing of the particles using the circular diameter graticule may be done by transforming mentally the image of each particle into a circle and then comparing it to the 10 µm and 25 µm graticule reference circles. The inner diameter of the transparent graticule reference circles is used to size white and transparent particles. Dark particles are sized by using the outer diameter of the black opaque graticule reference circles.

*NOTE* — Do not count or size amorphous, semi-liquid, or otherwise morphologically indistinct materials that have the appearance of a stain or show little or no surface relief and present a gelatinous or film-like appearance.

<i>Limits.</i>		
Table 1		
Sample	Particle size in $\mu\text{m}$ (equal to or greater than)	Maximum number of particles
Preparations in containers with nominal content of more than 100 ml	10	average in the units tested
	25	12 per cent
Preparations in containers with nominal content of 100 ml	10	2 per cent
	25	3000 per container
Less than 100 ml	10	300 per container
	25	3000 per container

The preparation meets the requirements of the test if it contains particles within the maximum limits shown in Table 1.

#### Method 2. Light obscuration particle count test

This method is not suitable for preparations with reduced clarity or increased viscosity such as emulsions, colloids, liposomal preparations and products that produce air or gas bubbles when drawn into the sensor.

*Precautions during testing.* The same general precautions as for Method 1 apply.

*Apparatus.* A suitable particle counter based on the principle of light blockage and capable of automatic counting and sizing of particles. The manufacturer's instructions for installation and operation should be followed.

The instrument should be calibrated with suitable certified reference materials consisting of dispersions or spherical particles of size in the range 10  $\mu\text{m}$  to 25  $\mu\text{m}$ . The materials should be dispersed in particle-free water, taking care to prevent aggregation of particles.

*Method.* Invert the container of the preparation under examination 20 times successively in order to mix the contents.

Wash the outer surface of the container with a jet of *particle-free water* and remove the closure carefully, avoiding contamination of the contents.

For large-volume parenterals, single units should be tested. For small-volume parenterals less than 25 ml in volume, the contents of 10 or more units should be combined in a clean container. Where the volume of liquid in a container is very small, the test solution may be prepared by mixing the contents of a suitable number of containers and diluting to 25 ml with *particle-free water*. Small-volume parenterals having a volume of 25 ml or more may be tested individually.

Powders for parenteral use should be constituted with *particle-free water*.

Remove 4 portions, each of not less than 5 ml, and count the number of particles equal to or greater than 10  $\mu\text{m}$  and 25  $\mu\text{m}$ . Ignore the result obtained for the first portion, and calculate the average number of particles in the preparation under examination.

<i>Limits.</i>		
Table 2		
Sample	Particle size in $\mu\text{m}$ (equal to or greater than)	Maximum number of particles
Preparations in containers with nominal content of more than 100 ml	10	average in the units tested
	25	25 per cent
Preparations in containers with nominal content of 100 ml	10	3 per cent
	25	6000 per container
Less than 100 ml	10	600 per container
	25	600 per container

The preparation meets the requirements of the test if it contains particles within the maximum limits shown in Table 2. If the average number of particles exceeds these limits, test the preparation by Method 1.

## 2.6. TESTS ON HERBAL PRODUCTS

2.6.1. Foreign Organic Matter	....
2.6.2. Ethanol-Soluble Extractive	....
2.6.3. Water-Soluble Extractive	.....
2.6.4. Complete Extraction of Alkaloids	....
2.6.5. Total Solids	....



### 2.6.1. Foreign Organic Matter

Foreign organic matter is the material consisting of any or all of the following.

- (1) Parts of the organ or organs from which the drug is derived other than the parts named in the definition and description or for which the limit is prescribed in the individual monograph.
- (2) Any organs other than those named in the definition and description.
- (3) Matter not coming from the source plant and
- (4) Moulds, insects or other animal contamination.

#### Method

Weigh 100 to 500 g, or the quantity specified in the individual monograph, of the *original sample* and spread it out in a thin layer. Inspect the sample with the unaided eye or with the use of a 6x lens and separate the foreign organic matter manually as completely as possible. Weigh and determine the percentage of foreign organic matter from the weight of the drug taken. Use the maximum quantity of sample for coarse or bulky drugs.

### 2.6.2. Ethanol-Soluble Extractive

Macerate 5 g of the air-dried drug, coarsely powdered, with 100 ml of *ethanol* of the specified strength in a closed flask for 24 hours, shaking frequently during the first 6 hours and allowing to stand for 18 hours. Thereafter, filter rapidly taking precautions against loss of ethanol, evaporate 25 ml of the filtrate to dryness in a tared flat-bottomed shallow dish, dry at 105° and weigh. Calculate the percentage of ethanol-soluble extractive with reference to the air-dried drug.

### 2.6.3. Water-Soluble Extractive

#### Method I

Proceed as directed for the determination of Ethanol-soluble Extractive, using *chloroform water* instead of *ethanol*.

#### Method II

Add 5 g to 50 ml of *water* at 80° in a stoppered flask. Shake well and allow to stand for 10 minutes, cool, add 2 g of *kieselguhr* and filter. Transfer 5 ml of the filtrate to a tared evaporating dish, 7.5 cm in diameter, evaporate the solvent on a water-bath, continue drying for 30 minutes, finally dry in a steam oven for 2 hours and weigh the residue. Calculate the percentage of water-soluble extractive with reference to the air-dried drug.

### 2.6.4. Complete Extraction of Alkaloids

Complete extraction is indicated by the following tests.

**When extracting with an aqueous or alcoholic liquid** — After extracting at least 3 times with the liquid, add to a few drops of the next portion, after acidifying with *2M hydrochloric acid* if necessary, 0.05 ml of *potassium mercuri-iodide solution* or, for solanaceous alkaloids, 0.05 ml of *potassium iodobismuthate solution*; no precipitate or turbidity is produced.

**When extracting with an immiscible solvent** — After extracting at least 3 times with the solvent, add to a few drops of the next portion 1 to 2 ml of *0.1M hydrochloric acid*, remove the organic solvent by evaporation, transfer the aqueous residue to a test-tube, and add 0.05 ml of *potassium mercuri-iodide solution* or, for solanaceous alkaloids, 0.05 ml of *potassium iodobismuthate solution* or, for emetine, 0.05 ml of *iodine solution*; not more than a very faint opalescence is produced.

**Continuous extraction** — After percolating for at least 2 hours, collect 1 to 2 ml of the effluent and carry out the procedure described under '**When extracting with an aqueous or alcoholic liquid**' or '**When extracting with an immiscible solvent**' as appropriate.

### 2.6.5. Total Solids

The term 'total solids' is applied to the residue obtained when the prescribed amount of the preparation is dried to constant weight under the conditions specified below.

#### Apparatus

Shallow, flat-bottomed, flanged dishes, about 75 mm in diameter and about 25 mm deep, made of nickel or other suitable metal of high heat conductivity and which is not affected by boiling *water*.

#### Method

Weigh accurately or measure an accurate quantity of the substance under examination stated in the individual monograph, place in a tared dish, evaporate at as low a temperature as possible until the solvent is removed and heat on a water-bath until the residue is apparently dry. Transfer to an oven and dry to constant weight at 105°, unless otherwise stated in the monograph. Owing to the hygroscopic nature of certain residues, it may be necessary to use dishes provided with well-fitting covers and to cool in a desiccator.

## 2.7. TESTS ON VACCINES

2.7.1.	Composition of Polysaccharide Vaccines	....
2.7.2.	Cell Substrates for the Production of Vaccines for Human Use	....
2.7.3.	Extraneous Agents in Viral Vaccines	....
2.7.4.	Test for Absence of Mycoplasmas	....
2.7.5.	Test for Neurovirulence (NVT) for Live Viral Vaccines	....
2.7.6.	Test for Neurovirulence (NVT) for Oral Poliomyelitis Vaccines (OPV)	....
2.7.7.	Test on Chicken Flocks Free from Specified Pathogens for the Production and Quality Control of Vaccines	....
2.7.8.	Test for Absence of Non-Avian Mycoplasmas and Ureaplasmas	....
2.7.9.	Test for Absence of Avian Mycoplasmas in Live Viral Poultry Vaccines	....
2.7.10.	Avian Live Vaccines-Test for Extraneous Agents in Seed Lot	....
2.7.11.	Avian Live Virus Vaccines - Test for Extraneous Agents in Batches of Finished Products	.....
2.7.12.	Evaluation of Efficacy of Vaccines and Immunosera	....

### 2.7.1. Composition of Polysaccharide Vaccines

#### O-Acetyl Groups

**Test solution.** In a graduated flask of suitable volume take a preparation of a solution containing about 5 mg per ml of dry polysaccharide. Transfer the contents of a container quantitatively to the flask and dilute with water to make up the required volume. Dilute the solution in a way that the volumes used in solution contain 30 to 600 µg of acetylcholine (O-acetyl). Take 0.3 ml, 0.5 ml and 1 ml in duplicate into six tubes (three reaction solutions and three correction solutions).

**Reference solutions.** Dissolve 0.150 g of acetylcholine chloride in 10 ml of water (stock solution containing 15 g of acetylcholine chloride per litre). Immediately before use, dilute 1 ml of the stock solution to 50 ml with water (working dilution 1:300 µg of acetylcholine chloride per ml). Immediately before use, dilute 1 ml of the stock solution to 25 ml with water (working dilution 2:600 µg of acetylcholine chloride per ml). Introduce 0.1 ml and 0.4 ml of working dilution 1 in duplicate (reaction and correction solutions) in four tubes and 0.6 ml and 1 ml of working dilution 2 in duplicate (reaction and correction solutions) in another four tubes. Prepare a blank using 1 ml of water.

**Method.** Make up the volume in each tube to 1 ml with water. Add 1 ml of 4M hydrochloric acid to each of the correction tubes and to the blank. Add 2 ml of alkaline hydroxylamine solution to each tube. Allow the reaction to proceed for exactly 2 minutes and add 1 ml of 4M hydrochloric acid to each of the reaction tubes. Add 1 ml of a 10.0 per cent w/v solution of ferric chloride in 0.1M hydrochloric acid to each tube, stopper the tubes and shake vigorously to remove bubbles.

Measure the absorbance (2.4.7) of each solution at 540 nm using the blank as compensation liquid. For each reaction solution, subtract the absorbance of the corresponding correction solution. Draw a calibration curve from the corrected absorbances for the four reference solutions and the corresponding content of acetylcholine chloride and read from the curve the content of acetylcholine chloride in the test solution for each volume tested. Calculate the mean of the three values.

1 mole of acetylcholine chloride (181.7 g) is equivalent to 1 mole of O-acetyl (43.05 g).

#### Hexosamines

**Test solution.** In a graduated flask of suitable volume take a preparation of a solution containing about 5 mg per ml of dry polysaccharide. Transfer the contents of a container quantitatively to the flask and dilute with water to make up the required volume. Dilute the solution so that the volumes used in the test contain 0.125 to 0.500 mg of glucosamine

(hexosamine). Add 1 ml of the diluted solution into a graduated tube.

**Reference solutions.** Dissolve 60 mg of D-glucosamine hydrochloride in 100 ml of water (stock solution containing 0.500 g of glucosamine per litre). Add 0.25 ml, 0.5 ml, 0.75 ml, and 1 ml of the working dilution into four graduated tubes. Prepare a blank using 1 ml of water.

**Method.** Make up the volume in each tube to 1 ml with water. Add 1 ml of 8M hydrochloric acid to each tube. Stopper the tubes and place in a water bath for 1 hour. Cool to room temperature. Add to each tube 0.05 ml of a 0.5 per cent w/v solution of thymolphthalein in ethanol (95.0 per cent); add 5M sodium hydroxide until a blue colour is obtained and then 1M hydrochloric acid till the solution becomes colourless. Dilute the volume to 10 ml with water in each tube (neutralised hydrolysates).

In a second series of 10-ml graduated tubes, place 1 ml of each neutralised hydrolysate. Add 1 ml of acetylacetone reagent (a mixture, prepared immediately before use, of 1 volume of acetylacetone and 50 volumes of a 5.3 per cent w/v solution of anhydrous sodium carbonate) to each tube. Stopper the tubes and place in a water bath at 90° for 45 minutes. Cool to room temperature. Add to each tube 2.5 ml of ethanol (95.0 per cent) and 1 ml of dimethylaminobenzaldehyde solution (prepared immediately before use by dissolving 0.8 g of dimethylaminobenzaldehyde in 15 ml of ethanol (95.0 per cent) and add 15 ml of hydrochloric acid) and dilute the volume in each tube to 10 ml with ethanol (95.0 per cent). Stopper the tubes, mix well by inverting and allow to stand in the dark for 90 minutes. Measure the absorbance (2.4.7) of each solution at 530 nm using the blank as compensation liquid.

Draw a calibration curve from the absorbances for the four reference solutions and the corresponding content of hexosamine and read from the curve the quantity of hexosamine in the test solution.

#### Methylpentoses

**Test solution.** In a graduated flask of suitable volume take a preparation of a solution containing about 5 mg per ml of dry polysaccharide. Transfer the contents of a container quantitatively to the flask and dilute with water to make up the required volume. Dilute the solution so that the volumes used in the test contain 2 to 20 µg of rhamnose (methylpentoses). Add 0.25 ml, 0.5 ml and 1 ml of the diluted solution into three tubes.

**Reference solutions.** Dissolve 0.100 g of rhamnose in 100 ml of water (stock solution containing 1 g of methylpentose per litre). Immediately before use, dilute 1 ml of the stock solution to 50 ml with water (working dilution: 20 mg of methylpentose per litre). Introduce 0.1 ml, 0.25 ml, 0.5 ml, 0.75 ml and 1 ml of the

working dilution into five tubes. Prepare a blank using 1 ml of *water*.

**Method.** Make up the volume in each tube to 1 ml with *water*. Place the tubes in iced *water* and add drop wise with continuous stirring to each tube 4.5 ml of a cooled mixture of 1 volume of *water* and 6 volumes of *sulphuric acid* to each tube. Warm the tubes to room temperature and place in a water bath. Cool to room temperature. Add to each tube 0.1 ml of a 3.0 per cent w/v solution of *cysteine hydrochloride*, prepared immediately before use. Shake well and allow to stand for 2 hours.

Measure the absorbance (2.4.7) of each solution at 396 nm and at 430 nm using the blank as compensation liquid. For each solution, calculate the difference between the absorbance measured at 396 nm and that measured at 430 nm. Draw a calibration curve from the absorbance differences for the five standard solutions and the corresponding content of methylpentose and read from the curve the quantity of methylpentose in the test solution for each volume tested. Calculate the mean of the three values.

#### Nucleic Acids

*Test solution.* Prepare a solution containing about 5 mg per ml of dry *polysaccharide*. Transfer the contents of a container quantitatively to the flask and dilute with *water* to make up the required volume.

**Method.** Dilute the test solution, if necessary to obtain an absorbance value suitable for the instrument used. Measure the absorbance (2.4.7) at 260 nm using *water* as compensation liquid. The absorbance of a 0.1 per cent w/v solution of *nucleic acid* at 260 nm is 20.

#### Phosphorus

*Test solution.* In a graduated flask of suitable volume take a preparation of a solution containing about 5 mg per ml of dry *polysaccharide*. Transfer the contents of a container quantitatively to the flask and dilute with *water* to make up the required volume. Dilutions should be made in a way that the volume used in the test solution (1 ml) contains about 6 mg of *phosphorus*. Transfer 1 ml of the solution to a 10 ml ignition tube.

*Reference solutions.* Dissolve 0.2194 g of *potassium dihydrogen orthophosphate* in 500 ml of *water* to make a solution equivalent to 0.1 mg of *phosphorus* per ml. Dilute 5 ml of the solution to 100 ml with *water*. Transfer 0.5 ml, 1 ml and 2 ml of the dilute solutions to three ignition tubes, respectively. Prepare a blank solution using 2 ml of *water* in the same manner.

**Method.** To all the tubes add 0.2 ml of *sulphuric acid* (96.0 per cent w/w) and heat in an oil bath at 120° for 1 hour then at 160° until white fumes begin to appear (about 1 hour). Add 0.1 ml of

*perchloric acid* and heat at 160° until the solution is decolorized (about 90 minutes). Cool and add to the tubes 4 ml each of *water* and *ammonium molybdate reagent*. Heat in a water bath at 37° for 90 minutes and cool. Adjust the volume to 10 ml with *water* and observe for blue colour.

Measure the absorbance (2.4.7) at 820 nm against a blank solution. Draw a calibration curve with the absorbances of the three dilutions of the reference solutions and read from the curve for the quantity of *phosphorus* in the test solution.

#### Protein Content

*Test solution.* In a graduated flask of suitable volume take a preparation of a solution containing about 5 mg per ml of dry *polysaccharide*. Transfer the contents of a container quantitatively to the flask and dilute with *water* to make up the required volume. Place 1 ml of the solution in a glass tube and add 0.15 ml of a 40.0 per cent w/v solution of *trichloroacetic acid*. Shake well, and allow to stand for 15 minutes, centrifuge for 10 minutes at 5,000 revolutions per minute and discard the supernatant. Add 0.4 ml of 0.1M *sodium hydroxide* to the residue obtained after centrifugation.

*Reference solutions.* Dissolve 0.1 g of *bovine albumin* in 100 ml of 0.1M *sodium hydroxide* (stock solution containing 1 g of *protein* per liter). Dilute 1 ml of the stock solution to 20 ml with 0.1M *sodium hydroxide* (working dilution 1.50 mg of *protein* per liter). Dilute 1 ml of the stock solution to 4 ml with 0.1M *sodium hydroxide* (working dilution 2:250 mg of *protein* per liter). Place in six glass tubes 0.1 ml, 0.2 ml and 0.4 ml of working dilution 1 and 0.15 ml, 0.2 ml and 0.25 ml of working dilution 2. Make up the volume in each tube to 0.4 ml using 0.1M *sodium hydroxide*. Prepare a blank solution using 0.4 ml of 0.1M *sodium hydroxide*.

**Method.** Add 2 ml of *cupri-tartaric solution* to each tube, shake well, and allow to stand for 10 minutes. Add to each tube 0.2 ml of a mixture of equal volumes of *phosphomolybdotungstic reagent* and *water*, solution should be prepared immediately before use. Stopper the tubes, mix to stand in the dark for 30 minutes. The blue colour is stable for 60 minutes. If necessary, centrifuge to obtain clear solutions.

Measure the absorbance (2.4.7), of each solution at 760 nm using the blank as compensation liquid. Draw a calibration curve from the absorbances of the six standard solutions and the corresponding protein contents and read from the curve the content of protein in the test solution.

#### Ribose

*Test solution.* In a volumetric flask of suitable volume take a preparation of a solution containing about 5 mg per ml of dry *polysaccharide*. Transfer the contents of a container quantitatively to the flask and dilute to volume with *water*. Dilute the solution so that the volumes used in the test contain



2.5 mg to 25 mg of ribose. Introduce 0.20 to 0.40 ml of the diluted solution into tubes in triplicate.

**Reference solutions.** Dissolve 25 mg of *ribose* in *water* and dilute to 100.0 ml with the same solvent (stock solution containing 0.25 g per litre of *ribose*). Immediately before use, dilute 1 ml of the stock solution to 10.0 ml with *water* (working dilution: 25 mg per litre of *ribose*). Introduce 0.10 ml, 0.20 ml, 0.40 ml, 0.60 ml, 0.80 ml and 1.0 ml of the working dilution into six tubes.

Prepare a blank using 2 ml of *water*.

Make up to volume in each tube to 2 ml with *water*. Shake well and add 2 ml of a 0.5 g per litre solution of *ferric chloride* in *hydrochloric acid* to each tube. Shake. Add 0.2 ml of a 100 g per litre solution of *orcinol* in *absolute ethanol*. Place the tubes in a water-bath for 20 minutes. Cool in iced water. Measure the absorbance (2.4.7) of each solution at 670 nm using the blank as the compensation liquid. Draw a calibration curve from the absorbance readings for the six reference solutions and the corresponding content of *ribose* and read from the curve the quantity of *ribose* in the test solution for each volume tested. Calculate the mean of the three values.

#### Sialic Acid

**Test solution.** Transfer quantitatively the contents of one or several containers to a volumetric flask of a suitable volume so that the resulting solution will give a concentration of about 250 µg per ml of *polysaccharide* and dilute with *water* to make up the required volume. With the help of a syringe, transfer 4.0 ml of this solution to a 10 ml ultra filtration cell suitable for the passage of molecules of relative molecular mass less than 50,000. Rinse the syringe twice with *water* and transfer the rinsings to the ultrafiltration cell. Carry out the ultrafiltration, with constant stirring, under *nitrogen* at a pressure of about 150 kPa. Refill the cell with *water* each time the volume of liquid in it has decreased to 1 ml and continue until 200 ml has been filtered and the remaining volume in the cell is about 2 ml. Using a syringe, transfer this residual liquid to a 10 ml volumetric flask. Wash the cell with three quantities, each of 2 ml, of *water*, transfer the washings to the flask and dilute to 10.0 ml with *water* (test solution). In each of two test-tubes place 2.0 ml of the test solution.

**Reference solutions.** Use the reference solutions prescribed in the monograph.

Prepare two series of three test-tubes, place in the tubes of each series 0.5 ml, 1.0 ml and 1.5 ml respectively, of the reference solution corresponding to the type of vaccine under examination and adjust the volume in each tube to 2.0 ml with *water*. Prepare blank solutions using 2.0 ml of *water* in each of two test-tubes. To all the tubes add 5.0 ml of *resorcinol reagent*. Heat at 105° for 15 minutes, cool in *cold water* and transfer the tubes to a bath of iced *water*. To each tube add 5 ml of *isoamyl alcohol* and mix thoroughly. Place in the bath

of iced water for 15 minutes. Centrifuge the tubes and keep them in the bath of iced water until the examination by absorption spectrophotometry is made. Measure the absorbance (2.4.7), of each supernatant solution at 580 nm and 450 nm using *isoamyl alcohol* as the compensation liquid. For each wavelength, calculate the absorbance as the mean of the values obtained with two identical solutions. Subtract the mean value for the blank solution from the mean values obtained for the other solutions. Draw a graph showing the difference between the absorbances at 580 to 450 nm of the reference solution as a function of the content of *N-acetylneuraminic acid* and read from the graph the quantity of *N-acetylneuraminic acid* (*sialic acid*) in the test solution.

#### Uronic Acids

**Test solution.** In a graduated flask of suitable volume take a preparation of a solution containing about 5 mg per ml of dry *polysaccharide*. Transfer the contents of a container quantitatively to the flask and dilute with *water* to make up the required volume. Dilute the solution so that the volumes used in the test contain 4 to 40 µg of *glucuronic acid* (*uronic acids*). Add 0.25 ml, 0.5 ml and 1 ml of the diluted solution into three tubes.

**Reference solutions.** Dissolve 50 mg of *sodium glucuronate* in 100 ml of *water* (stock solution containing 0.4 g of *glucuronic acid* per litre). Immediately before use, dilute 5 ml of the stock solution to 50 ml with *water* (working dilution: 40 mg of *glucuronic acid* per litre). Introduce 0.1 ml, 0.25 ml, 0.5 ml, 0.75 ml and 1 ml of the working dilution into five tubes. Prepare a blank using 1 ml of *water*.

**Method.** Make up to volume in each tube to 1 ml with *water*. Place the tubes in iced *water* and add dropwise with continuous stirring to each tube 5 ml of *borate solution*. Stopper the tubes and place in a water bath for 15 minutes. Cool to room temperature. Add 0.2 ml of a 0.125 per cent w/v solution of *carbazole* in *absolute ethanol* to each tube. Stopper the tubes and place in a water bath for 15 minutes. Cool to room temperature. Measure the absorbance (2.4.7) of each solution at 530 nm using the blank as compensation liquid.

Draw a calibration curve from the absorbances for the five standard solutions and the corresponding content of glucuronic acid and read from the curve the quantity of glucuronic acid in the test solution for each volume tested. Calculate the mean of the three values.

### 2.7.2 Cell Substrates for the Production of Vaccines for Human Use

This chapter deals with various cell lines such as diploid and continuous cell lines used for the production of vaccines for human use. Testing to be carried out at various stages (cell

seed, master cell bank, working cell bank, cells at or beyond the maximum population doubling level used for production).

**Diploid cell line.** Diploid cell line has a high but finite capacity for multiplication *in vitro*.

**Continuous cell line.** A continuous cell line has a capacity to multiply indefinitely *in vitro*. It may be obtained from healthy or tumoral tissue.

For injectable vaccines produced in continuous cell lines the purification process is validated to demonstrate removal of substrate-cell DNA to a level equivalent to not more than 10 ng per single human dose, unless otherwise prescribed.

**Cell bank system.** Production of vaccines in diploid and continuous cell lines is based on a cell bank system. The *in vitro* age of the cells is counted from the master cell banks. Each working cell bank is prepared from one or more containers of the master cell banks. Diploid cell lines such as MRC-5 and WI 38 can be used for production upto a level of 10 generations before senescence.

**Cell seed.** Cell seed shall have the information on source, history and characterization. For characterization of the cell seed the properties such as the identity of the cells (for example; isoenzymes, DNA fingerprinting), karyotype, growth characteristics, viral susceptibility and viability during storage and finite life span of the cells.

**Test for extraneous agents.** Cell lines for vaccine production shall be free from infectious agents. Test will depend on the origin and culture history of the cell line particularly those which are known to infect latently the species of origin such as simian virus 40 (SV40) in cell line derived from monkeys and other viruses in case of cell lines of rodent origin.

**Tumorigenicity.** For the preparation of live vaccines, cell line must not be tumorigenic at any population doubling level used for vaccine production. Tumorigenicity test is carried out by *in vivo* test in one of the animal systems such as athymic mice (Nu/Nu genotype), new born mice, rats or hamsters that have been treated with anti-thymocyte serum or globulin, thymectomised and irradiated mice that have been reconstituted (T<sup>+</sup>, B<sup>+</sup>) bone marrow from healthy mice.

MRC-5, the WI-38 and the FRhL-2 cells lines are recognized as being non-tumorigenic and further testing is not necessary.

**Chromosomal characterization.** Comply with the test for extraneous agents (2.7.3) in cell culture. The cells are of Syrian origin they are also inoculated into rabbit kidney cell cultures to test for herpes virus B (*Cercopithecoid herpes virus 1*).

**Retroviruses.** Examine for the presence of retroviruses using one of the tests such as infectivity assays, transmission electronic microscopy or reverse transcriptase assays.

**Tests in animals.** Inject intramuscularly (or, for suckling mice, by deep subcutaneous route) into each of the following groups

of animals at least 10<sup>7</sup> viable cells divided equally between the animals in each group:

- (a) two litters of suckling mice less than 24 hours old, comprising no less than 10 animals,
- (b) ten adult mice,
- (c) five guinea-pigs,
- (d) five rabbits.

Observe the animals for at least 4 weeks. Investigate animals that become sick or show any abnormality to establish the cause of illness. No evidence of any extraneous agent is found. The test is not valid unless at least 80.0 per cent of the animals in each group remain healthy and survive to the end of the observation period.

Cells obtained from rodent species (for example Chinese hamster ovary cells or baby hamster kidney cells) tests for antibodies against viral contaminants of the species (rodent) are carried out on animals that have received injection of the cells.

**Tests in eggs.** Using an inoculum of 10<sup>6</sup> viable cells per egg, inoculate the cells into the allantoic cavity of 10 SPF embryonated eggs (2.7.7) 9 to 11 day old and into the yolk sac of 10 SPF embryonated hen's eggs, 5 to 6 days old. Incubate for not less than 5 days. Test the allantoic fluids for five days for the presence of haemagglutinins using mammalian and avian red blood cells. No evidence of extraneous agent is found. The test is not valid if less than 80 per cent of the embryos remain healthy and alive till the end of observation period.

**Chromosomal monitoring.** Examine at least 500 cells in metaphase at the production level or at any passage thereafter. Carry out examination for the same features and in the same manners as described above. Only cell banks that have normal karyotype are used for vaccine production.

**Sterility** (2.2.11). Complies with the test for sterility using 10 ml sample.

**Mycoplasmas** (2.7.4). Complies with the test for absence of mycoplasmas using 10 ml sample.

**Test for extraneous agents in cell cultures** (2.7.3). Complies with the test for extraneous agents in cell cultures.

### 2.7.3. Extraneous Agents in Viral Vaccines

In those tests that require prior neutralisation of the virus, use specific antibodies of non-human, non-simian origin; if the virus has been propagated in avian tissues, the antibodies must also be of non-avian origin. To prepare antiserum, use an immunising antigen produced in cell culture from a species different from that used for the production of the vaccine and free from extraneous agents. Where the use of SPF eggs is prescribed, the eggs comply with the requirements prescribed

above under Chicken flocks free from specified pathogens for the production and quality control of vaccines.

**Virus seed lot.** Take samples of the virus seed lot at the time of harvesting and, if not tested immediately, keep them at a temperature below  $-60^{\circ}$ .

**Adult mice.** Inoculate each of at least 10 adult mice, each weighing between 15 to 20 g, intracerebrally with 0.03 ml and intraperitoneally with 0.5 ml of the virus seed lot. Observe the mice for at least 21 days. Carry out autopsy of all mice that die after the first 24 hours of the test or that show signs of illness and examine for evidence of viral infection, both by direct macroscopical observation and by subinoculation of appropriate tissue suspensions by the intracerebral and intraperitoneal routes into at least five additional mice which are observed for 21 days. The virus seed lot complies with the test if no mouse shows evidence of infection attributable to the seed lot. The test is not valid unless at least 80.0 per cent of the original inoculated mice survive the observation period.

**Suckling mice.** Inoculate each of at least 20 mice, less than 24 hours old, intracerebrally with 0.01 ml and intraperitoneally with at least 0.1 ml of the virus seed lot. Observe the mice daily for at least 14 days. Carry out autopsy of all mice that die after the first 24 hours of the test or that show signs of illness and examine for evidence of viral infection, both by direct macroscopical observation and by subinoculation of appropriate tissue suspensions by the intracerebral and intraperitoneal routes into at least five additional suckling mice which are observed daily for 14 days. The virus seed lot passes the test if no mouse shows evidence of infection attributable to the seed lot. The test is not valid unless at least 80.0 per cent of the original inoculated mice survive the observation period.

**Guinea-pigs.** Inoculate intraperitoneally into each of at least five guinea-pigs, each weighing between 350 to 450 g, 5 ml of the virus seed lot. Observe the animals for at least 42 days for signs of disease. Carry out autopsy of all guinea-pigs that die after the first 24 hours of the test, or that show signs of illness and examine macroscopically; examine the tissues both microscopically and culturally for evidence of infection. Kill animals that survive the observation period and examine in a similar manner. The virus seed lot passes the test if no guinea-pig shows evidence of infection attributable to the seed lot. The test is not valid unless at least 80.0 per cent of the guinea-pigs survive the observation period.

**Virus seed lot and virus harvest.** Take samples at the time of harvesting and, if not tested immediately, keep them at a temperature below  $-60^{\circ}$ .

**Sterility** (2.2.11). Complies with the test for sterility using 10 ml sample.

**Mycobacteria.** Carry out the test for the presence of *Mycobacterium* spp. by culture methods known to be sensitive for the detection of these organisms using 5 ml sample.

**Other extraneous agents** (*test in cell culture*). Samples equivalent, unless otherwise prescribed, to 500 doses of vaccine or 50 ml, whichever is the greater, are tested for the presence of extraneous agents by inoculation into continuous simian kidney and human cell cultures. If the virus is grown in human diploid cells, the neutralised virus harvest is also tested on a separate culture of the diploid cells. If the vaccine virus is grown in a cell system other than simian or human, cells of that species, from a separate culture, are also inoculated. The cells are incubated at  $35^{\circ}$  to  $37^{\circ}$  and observed for a period of 14 days. The virus seed lot or harvest passes the tests if none of the cell cultures shows evidence of the presence of any extraneous agents not attributable to accidental contamination. The test is not valid unless at least 80.0 per cent of the cell cultures remain available for observation during the observation period.

**Avian viruses** (*required only for virus propagated in avian tissues*). Neutralise a sample equivalent to 100 doses or 10 ml, whichever is the greater. Using 0.5 ml per egg, inoculate a group of fertilised SPF eggs, 9 to 11 days old, by the allantoic route and a second group, 5 to 7 days old, into the yolk sac. Incubate for 7 days. The virus seed lot or harvest complies with the test if the allantoic and yolk sac fluids show no sign of the presence of any haemagglutinating agent and if all embryos and chorio-allantoic membranes, examined for gross pathology, are normal. The test is not valid unless at least 80.0 per cent of the inoculated eggs survive for 7 days.

#### **Production cell culture: Control cells**

Examine the control cells microscopically for freedom from any virus causing cytopathic degeneration throughout the time of incubation of the inoculated production cell cultures or for not less than 14 days beyond the time of inoculation of the production vessels, whichever is the longer. The test is not valid unless at least 80.0 per cent of the control cell cultures survive to the end of the observation period.

At 14 days or at the time of the last virus harvest, whichever is the longer, carry out the tests described below.

**Haemadsorbing viruses.** Examine not less than 25.0 per cent of the control cultures for the presence of haemadsorbing viruses by the addition of guinea pig red blood cells. If the guinea pig red blood cells have been stored, they shall have been stored at  $2^{\circ}$  to  $8^{\circ}$  for not more than 7 days. Read half of the cultures after incubation at  $2^{\circ}$  to  $8^{\circ}$  for 30 minutes and the other half after incubation at  $20^{\circ}$  to  $25^{\circ}$  for 30 minutes. No evidence of haemadsorbing agents is found.

**Other extraneous agents** (*tests in cell cultures*). Pool the supernatant fluids from the control cells and examine for the presence of extraneous agents by inoculation of simian kidney and human cell cultures. If the vaccine virus is grown in a cell system other than simian or human, cells of that species, but from a separate culture, are also inoculated. In each cell system,



at least 5 ml is tested. Incubate the inoculated cultures at a temperature of 35° to 37° and observe for a period of 14 days. No evidence of extraneous agents is found.

**Avian leucosis viruses** (*required only if the virus is propagated in avian tissues*). Carry out a test for avian leucosis viruses on the supernatant fluid from the control cells.

#### Control eggs

**Haemagglutinating agents.** Examine 0.25 ml of the allantoic fluid from each egg for haemagglutinating agents by mixing directly with chicken red blood cells and after a passage in SPF eggs carried out as follows. Inoculate a 5 ml sample of the pooled amniotic fluids from the control eggs in 0.5 ml volumes into the allantoic cavity and into the amniotic cavity of SPF eggs. The control eggs comply with the test if no evidence of the presence of haemagglutinating agents is found in either test.

**Avian leucosis viruses.** Use a 10 ml sample of the pooled amniotic fluids from the control eggs. Carry out amplification by five passages in leucosis-free, chick-embryo cell cultures; carry out a test for avian leucosis using cells from the fifth passage. The control eggs comply with the test if no evidence of the presence of avian leucosis viruses is found.

**Other extraneous agents.** Inoculate 5 ml samples of the pooled amniotic fluids from the control eggs into human and simian cell cultures. Observe the cell cultures for 14 days. The control eggs comply with the test if no evidence of the presence of extraneous agents is found. The test is not valid unless 80.0 per cent of the inoculated cultures survive to the end of the observation period.

### 2.7.4. Test for Absence of Mycoplasmas

The test for *Mycoplasma* is prescribed for master cell bank, working cell bank, virus seed lots, control cells, virus harvests, bulk vaccine and for the final lot (batch). The methods shall be used as described below.

Master Cell Bank	Standard culture method and/or indicator cell culture method
Working Cell Bank	Standard culture method and/or indicator cell culture method
Virus Seed Lots	Standard culture method and/or indicator cell culture method
Control Cells	Standard culture method and/or indicator cell culture method
Virus Harvest	Standard culture method
Bulk Vaccine	Standard culture method
Final Lot	Standard culture method

Alternative methods may also be used provided they have been validated against the methods described above.

#### Standard culture method

**Culture media.** The test is carried out using a sufficient number of both solid and liquid media to ensure growth in the stated incubation conditions of small numbers of *mycoplasmas* that may be present in the preparation under examination. Liquid media must contain *phenol red dye*. The media must have satisfactory nutritive properties for at least the organisms described below. The nutritive properties of each new batch of medium are verified for the appropriate organisms in the list.

*Acholeplasma laidlawii* (vaccines where an antibiotic has been used during preparation).

*Mycoplasma gallisepticum* (where avian material has been used during production of vaccine or where the vaccine is intended to be used in poultry).

*Mycoplasma synoviae* (where avian material has been used during production of vaccine or where the vaccine is intended to be used in poultry).

*Mycoplasma orale* (for vaccines of human use).

*Mycoplasma pneumoniae* or other suitable species of D-glucose fermenter (*for vaccines of human use*).

The test strains at low passage are used and are frozen or freeze dried. The test strains are field isolates having undergone not more than fifteen subcultures and are stored frozen or freeze-dried. After cloning the strains are identified as being of the required species by a suitable method, and are compared with type cultures, for example.

<i>A. laidlawii</i>	NCTC 10116	CIP 75.27	ATCC 23206
<i>M. gallisepticum</i>	NCTC 10115	CIP 104967	ATCC 19610
<i>M. orale</i>	NCTC 10112	CIP 104969	ATCC 23714
<i>M. pneumoniae</i>	NCTC 10119	CIP 103766	ATCC 15531
<i>M. synoviae</i>	NCTC 10124	CIP 104970	ATCC 25204

**Incubation condition.** Inoculated media is divided into two equal parts and one part is incubated in aerobic conditions and the other part is incubated in micro aerophilic conditions.

#### Aerobic conditions

Liquid Media	Incubation in an atmosphere of air.
Solid Media	Incubation in an atmosphere, which must contain 5 to 10 per cent carbon dioxide and adequate humidity to prevent desiccation.



**Microaerophilic conditions**

Liquid Media	Incubation in an atmosphere of nitrogen.
Solid Media	Incubation in an atmosphere of nitrogen containing 5 to 10 per cent Carbon dioxide and adequate humidity to prevent desiccation.

**Test for nutritive properties.** Each new batch of medium must be subjected for this test by inoculating the chosen media with suitable number of test organisms as described below.

60 mm plate containing 9 ml of media	Not more than 100 colony forming units.
100 ml of liquid media.	Not more than 40 colony forming units.

Use separate plate and containers for each species of organisms and incubate the media aerobically and microaerophilically as described under "Incubation condition". The media complies with the test for nutritive properties if there is adequate growth of the test organisms with an appropriate colour change in liquid media.

**Inhibitory substances.** Carry out the test for nutritive properties in the presence of the preparation under examination. If growth of the test organisms is notably less than that found in the absence of the preparation under examination, the latter contains inhibitory substances that must be neutralized (for example, by dilution) before the test for *mycoplasmas* is carried out. The effectiveness of the neutralization or other process is checked by repeating the test for inhibitory substances after neutralization.

**Test for mycoplasmas.** Carry out the test for *Mycoplasma* in the preparation under examination by inoculating the appropriate volume of the preparation as described below.

Media	Inoculum
60 mm plate containing 9 ml of media	0.2 ml
100 ml of liquid media	10 ml

Inoculate at least 2 plates of solid medium and at least 2 tubes of liquid media for the preparation under examination. Incubate at 35° to 38° aerobically and microaerophilically as described under "Incubation condition" for 21 days.

At the same time, incubate an uninoculated 100 ml portion of liquid medium to serve as control, if pH change occurs significantly on the addition of the preparation in liquid medium restore the original pH of the liquid medium by the addition of a solution of *sodium hydroxide* or *hydrochloric acid*. Subculture each liquid medium on 1<sup>st</sup>, 2<sup>nd</sup> or 3<sup>rd</sup> day by inoculating each of two plates of each solid medium with 0.2 ml and incubating at 35° to 38° aerobically and microaerophilli-

cally for further 21 days. Repeat the procedure on 6<sup>th</sup>, 7<sup>th</sup> or 8<sup>th</sup> day and again on 13<sup>th</sup> or 14<sup>th</sup> day of the test. Observe the liquid media every 2 or 3 days and if there is any change in colour, subculture immediately. Observe solid media once per week.

If the liquid media show bacterial or fungal contamination, repeat the test. If, not earlier than 7 days after inoculation, not more than one plate at each stage of the test is accidentally contaminated with bacteria or fungi, or broken, that plate may be ignored provided that on immediate examination it shows no evidence of *mycoplasma* growth. If, at any stage of the test, more than one plate is accidentally contaminated with bacteria or fungi, or broken, the test is invalid and must be repeated. Include in the test positive controls produced by inoculating not more than 100 colony forming units of suitable test strains.

At the end of the incubation period, examine the inoculated solid media microscopically for the presence of *Mycoplasma*. The product passes the test if the growth of *mycoplasmas* has not occurred in any of the inoculated media, if growth of *mycoplasmas* does not occur, the preparation passes with the test. "If growth of *mycoplasmas* has occurred, the test may be repeated once using twice the amount of *inoculum*, media and plates; if growth of *mycoplasmas* does not occur, the product complies with the test." The test is invalid if the positive controls *do* not show growth of the relevant test organism.

**Indicator cell culture method.** Cell cultures are stained with a fluorescent dye that binds to DNA. *Mycoplasmas* are detected by their characteristic particulate or filamentous pattern of fluorescence on the cell surface and, if contamination is heavy, the *Mycoplasma* are detected in surrounding areas.

**Verification of the substrate.** Using a Vero cell culture substrate, pretest the procedure using an Inoculum of not more than 100 CFU (colony-forming units) of a strain growing readily in liquid or solid medium and demonstrate its ability to detect potential *mycoplasma* contaminants such as suitable strains of *Mycoplasma orale* strain 1596 and *Mycoplasma hyorhinitis* strain DBS or any other suitable strain. A different cell substrate may be used, for example the vaccine production cell line, if it has been demonstrated that it will provide at least equal sensitivity for the detection of potential *mycoplasma* contaminants.

**Procedure**

- Seed culture at a regular density ( $2 \times 10^4$  to  $2 \times 10^5$  cells/ml,  $4 \times 10^3$  to  $2.5 \times 10^4$  cells/cm<sup>2</sup>) and incubate at  $36^\circ \pm 1^\circ$  for at least 2 days. Inoculate 1ml of the preparation under examination and incubate for at least 2 days unless around 50.0 per cent confluence is reached; make at least one passage. Grow the last subculture on coverslips in suitable containers or on some other surface suitable for the test

procedure. Do not allow the last subculture to reach confluence since this would inhibit staining and impair visualisation of *mycoplasmas*.

- (b) Remove and discard the medium.
- (c) Rinse the monolayer with *phosphate buffered saline pH 7.4*, then with a mixture of equal volumes of *phosphate buffered saline pH 7.4* and a suitable fixing solution such as *methanol* and finally with the fixing solution such as *methanol*; when *bisbenzimidide* is used for staining, a freshly prepared mixture of 1 volume of *glacial acetic acid* and 3 volumes of *methanol* is a suitable fixing solution.
- (d) Add the fixing solution and allow to stand for 10 min.
- (e) Remove the fixing solution and discard.
- (f) If the monolayer is to be stained later, dry it completely. (*Particular care is needed for staining of the slides after drying because of artefacts that may be produced.*)
- (g) If the monolayer is to be stained immediately, wash off the *fixing solution* twice with *sterile water* and discard the wash.
- (h) Add *bisbenzimidide working solution* or some other suitable DNA staining agent and allow it to stand for 10 minutes.
- (i) Remove the stain and rinse the monolayer with *sterile water*.
- (j) Mount each coverslip, where applicable, with a drop of a mixture of equal volumes of *glycerol* and *phosphate-citrate buffer solution pH 5.5*; blot off excess amount from the edge of the cover slip.
- (k) Examine by epifluorescence (330 nm/380 nm excitation filter, LP 440 nm barrier filter) at 100 to 400 × magnification or greater.
- (l) *Compare the microscopic appearance* of the test cultures with that of the negative and positive controls, examining for extra nuclear fluorescence. *Mycoplasmas* give pinpoint or filaments over the cytoplasm and sometimes in intercellular spaces.

The preparation under examination complies with the test if there is no evidence of the presence of *mycoplasmas* in the test cultures inoculated with it. The test is invalid if the positive controls do not show the presence of the appropriate test organisms.

Include in the test a negative (non-infected) control and two positive *Mycoplasma* controls, of suitable test strains. Use an Inoculum of not more than 100 CFU for the positive controls.

If for viral suspensions the interpretation of results is affected by marked cytopathic effects, the virus may be neutralized using a specific antiserum that has no inhibitory effects on *mycoplasmas* or by using a cell culture substrate that does

not allow growth of the virus. The absence of inhibitory effects of serum must be demonstrated by carrying out the positive control tests in the presence and absence of the antiserum.

The following section is given for information and guidance; it does not form a mandatory part of the general method.

#### Special reagents for indicator cell culture method

*Bisbenzimidide* ( $C_{25}H_{27}Cl_3N_6O \cdot 5H_2O$  ( $M_r$  624) 4-[5-[5-(4-methylpiperazin-1-yl) benzimidazol-2-yl] benzimidazol-2-yl] phenol trihydrochloride pentahydrate.

*Bisbenzimidide stock solution*. To prepare stock solution, dissolve 5 mg of *bisbenzimidide* in sterile water and dilute to 100 ml with the same solvent. Store in the dark.

*Bisbenzimidide working solution*. To prepare working solution, dilute 10 µl of *bisbenzimidide* stock solution to 100 ml with *phosphate buffered saline at pH 7.4*. Use immediately.

*Phosphate-citrate buffer solution, pH 5.5*. To prepare buffer, mix 56.85 ml of a 2.84 per cent (28.4 g per litre) solution of *anhydrous disodium hydrogen phosphate* and 43.15 ml of a 2.1 per cent (21 g per litre) solution of *citric acid*."

#### Recommended media for the standard culture method

The following media are recommended. Other media may be used provided their ability to sustain the growth of *mycoplasmas* has been demonstrated on each batch in the presence and absence of the preparation under examination.

#### I. Recommended media for the detection of *Mycoplasma gallisepticum*

##### (a) Liquid medium

Beef heart infusion broth (1)	90.0 ml
Horse serum (unheated)	20.0 ml
Yeast extract (250 g per litre)	10.0 ml
Thallium acetate (10 g per litre solution)	1.0 ml
Phenol red (0.6 g per litre solution)	5.0 ml
Penicillin (20,000 IU per ml)	0.25 ml
Deoxyribonucleic acid (2 g per litre solution)	1.2 ml
Adjust to pH 7.8.	

##### (b) Solid medium

Prepare as described above replacing beef heart infusion broth by beef heart infusion agar containing 15 g per litre of agar.

#### II. Recommended media for the detection of *Mycoplasma synoviae*

<b>(a) Liquid medium</b>	
Beef heart infusion broth (1)	90.0 ml
Essential vitamins (2)	0.025 ml
Glucose monohydrate (500 g per litre solution)	2.0 ml
Swine serum (Inactivated at 56° for 30 minutes)	12.0 ml
β-Nicotinamide adenine dinucleotide (10 g per litre solution)	1.0 ml
Cysteine hydrochloride (10 g per litre solution)	1.0 ml
Phenol red (0.6 g per litre solution)	5.0 ml
Penicillin (20,000 IU per ml)	0.25 ml

Mix the solutions of *B-nicotinamide adenine dinucleotide* and *cysteine hydrochloride* and after 10 minutes add to the other ingredients. Adjust to pH 7.8.

<b>(b) Solid medium</b>	
Beef heart infusion broth (1)	90.0 ml
Ionagar (3)	1.4 g
Adjust to pH 7.8, sterilise by autoclaving then add.	
Essential vitamins (2)	0.025 ml
Glucose monohydrate (500 g per litre solution)	2.0 ml
Swine serum (unheated)	12.0 ml
β-Nicotinamide adenine dinucleotide (10 g per litre solution)	1.0 ml
Cysteine hydrochloride (10 g per litre solution)	1.0 ml
Phenol red (0.6 g per litre solution)	5.0 ml
Penicillin (20,000 IU per ml)	0.25 ml

### III. Recommended media for the detection of non-avian mycoplasmas

<b>(a) Liquid medium</b>	
Hanks' balanced salt solution (modified) (4)	800 ml
Distilled water	67 ml
Brain heart infusion (5)	135 ml
PPLO Broth (6)	248 ml
Yeast extract (170 g per litre)	60 ml
Bacitracin	250 mg
Meticillin	250 mg
Phenol red (5 g per litre)	4.5 ml

Thallium acetate (56 g per litre)	3 ml
Horse serum	165 ml
Swine serum	165 ml
Adjust to pH 7.4 to 7.45.	

<b>(b) Solid medium</b>	
Hanks' balanced salt solution (modified) (4)	200 ml
DEAE-dextran	200 mg
Ionagar (3)	15.65 mg

Mix well and sterilise by autoclaving. Cool to 100°. Add to 1740 ml of liquid medium as described above.

<b>(1) Beef heart infusion broth</b>	
Beef heart (for preparation of the infusion)	500 g
Peptone	10 g
Sodium chloride	5 g
Distilled water to	1000 ml
Sterilize by autoclaving.	

<b>(2) Essential vitamins</b>	
Biotin	100 mg
Calcium pantothenate	100 mg
Choline chloride	100 mg
Folic acid	100 mg
i-Inositol	200 mg
Nicotinamide	100 mg
Pyridoxal hydrochloride	100 mg
Riboflavine	10 mg
Thiamine hydrochloride	100 mg
Distilled water to	1000 ml

<b>(3) Ionagar</b>	
A highly refined agar for use in microbiology and immunology prepared by an ion-exchange procedure, which results in a preparation having superior purity, clarity and gel strength. It contains about:	
Water	12.2 per cent
Ash	1.5 per cent
Acid-insoluble ash	0.2 per cent
Phosphate (calculated as P <sub>2</sub> O <sub>5</sub> )	0.3 per cent
Total nitrogen	0.3 per cent
Copper	8 ppm
Iron	170 ppm
Calcium	0.28 per cent
Magnesium	0.32 per cent

**(4) Hanks' balanced salt solution (modified)**

Sodium chloride	6.4	g
Potassium chloride	0.32	g
Magnesium sulphate heptahydrate	0.08	g
Magnesium chloride hexahydrate	0.08	g
Calcium chloride, anhydrous	0.112	g
Disodium hydrogen phosphate dihydrate	0.0596	g
Potassium dihydrogen phosphate, anhydrous	0.048	g
Distilled water	800	ml

**(5) Brain heart infusion**

Calf-brain infusion	200	g
Beef-heart infusion	250	g
Proteose peptone	10	g
Glucose	2	g
Sodium chloride	5	g
Disodium hydrogen phosphate, anhydrous	2.5	g
Distilled water to	1000	ml

**(6) PPLO broth**

Beef-heart infusion	50	g
Peptone	10	g
Sodium chloride	5	g
Distilled water to	1000	ml

**2.7.5. Test for Neurovirulence (NVT) for Live Viral Vaccines**

For each test, use not less than 10 monkeys that are seronegative for the virus under test. For each monkey, inject not more than 0.5 ml of the material under examination into the thalamic region of each hemisphere, unless otherwise prescribed. The total amount of virus inoculated in each monkey must be not less than the amount contained in the recommended single human dose of the vaccine. As a check against the introduction of wild neurovirulent virus, keep a group of not less than four control monkeys as cage-mates or in the immediate vicinity of the inoculated monkeys. Observe the inoculated monkeys for 17 to 21 days for symptoms of paralysis and other evidence of neurological involvement; observe the control monkeys for the same period plus 10 days. Animals that die within 48 hours of injection are considered to have died from non-specific causes and may be replaced. The test is not valid if more than 20.0 per cent of the inoculated

monkeys die from nonspecific causes; serum samples taken from the control monkeys at the time of inoculation of the test animals and 10 days after the latter are killed show evidence of infection by wild virus of the type to be tested or by measles virus. At the end of the observation period, carry out autopsy and histopathological examinations of appropriate areas of the brain for evidence of central nervous system involvement. The material complies with the test if there is no unexpected clinical or histopathological evidence of involvement of the central nervous system attributable to the inoculated virus.

**2.7.6. Test for Neurovirulence (NVT) for Oral Poliomyelitis Vaccine (OPV)**

Monkeys used in the Neurovirulence test (NVT) comply with the requirements stated under Poliomyelitis Vaccine, Live (Oral) and weigh not less than 1.5 kg. The pathogenicity for *Macaca* or *Cercopithecus* monkeys is tested in comparison with that of a reference virus preparation for neurovirulence testing by inoculation into the lumbar region of the central nervous system after sedation with a suitable substance, for example, *ketamine hydrochloride*. A sample of serum taken before the injection shall be shown not to contain neutralising antibody at a dilution of 1.4 when tested against not more than 1,000 CCID<sub>50</sub> of each of the three types of poliovirus.

*Number of monkeys.* The vaccine and the appropriate homotypic reference virus are tested concurrently in the same group of monkeys. Equal numbers of animals are inoculated with the vaccine under examination and the reference preparation. The animals are allocated randomly to treatment groups and cages and their identity is coded so that the treatment received by each animal is concealed from the observers and the evaluators of the sections. The number of monkeys inoculated is such that in the evaluation of both the vaccine and the reference preparation not less than 11 positive monkeys are included for type 1 and type 2 virus and not less than 18 positive monkeys for type 3 virus (positive monkeys are those that show specific neuronal lesions of poliovirus in the central nervous system). More than one batch of vaccine may be tested with the same homotypic reference. Monkeys from the same quarantine group are used wherever possible, otherwise monkeys from two groups are used and equal numbers from each group are treated with the vaccine and the reference preparation. If the test is carried out on two working days, an equal number of monkeys from each group are inoculated on each day with the vaccine and the homotypic reference preparation.

*Virus content.* The virus contents of the vaccine and the homotypic reference preparation are adjusted so as to be as near as possible equal and between 10<sup>5.5</sup> and 10<sup>6.5</sup> CCID<sub>50</sub> per 0.1 ml.



*Observation.* All monkeys are observed for 17 to 22 days for signs of poliomyelitis or other virus infection. Monkeys that survive the first 24 hours but die before the 11th day after inoculation are autopsied to determine whether poliomyelitis was the cause of death. Animals that die from causes other than poliomyelitis are excluded from the evaluation. Animals that become moribund or are severely paralysed are killed and autopsied. All animals that survive until the end of the observation period are autopsied. The test is not valid if more than 20.0 per cent of the animals show intercurrent infection during the observation period.

*Number of sections examined.* The lumbar cord, the cervical cord, the lower and upper medulla oblongata, the midbrain, the thalamus and the motor cortex of each monkey, as a minimum, are subjected to histological examination. Sections are cut with a thickness of 15 µm and stained with *gallocyenin*. The minimum number of sections examined is as follows.

- 12 sections representative of the whole of the lumbar enlargement,
- 10 sections representative of the whole of the cervical enlargement,
- 2 sections from the medulla oblongata,
- 1 section from the pons and cerebellum,
- 1 section from the midbrain,
- 1 section from the left and the right of the thalamus,
- 1 section from the left and the right motor cerebral cortex.

*Scoring of virus activity.* For the evaluation of virus activity in the hemisections of the spinal cord and brain-stem, a score system for the severity of lesions is used, differentiating cellular infiltration and destruction of neurons as follows.

- Cellular infiltration only (the monkey is not counted as positive),
- Cellular infiltration with minimal neuronal damage,
- Cellular infiltration with extensive neuronal damage.
- Massive neuronal damage with or without cellular infiltration.

The scores are recorded on a standard form (a suitable form is shown in the requirements for Poliomyelitis Vaccine (Oral) {(Requirements for biological substances No.7 World Health Organization). A monkey with neuronal lesions in the sections but that shows no needle tract is counted as positive. A monkey showing a needle tract in the sections, but no neuronal lesions is not regarded as positive. A section that shows damage from trauma but no specific virus lesions is not included in the score.

Severity scores are based on hemisection readings of the lumbar (L), cervical (C) and brain (B) histological sections. The lesion score (LS) for each positive monkey is calculated as follows.

$$LS = \frac{\left[ \begin{array}{c} \text{Sum of} \\ \text{L score} \\ \text{Number of} \\ \text{hemisections} \end{array} \right] + \left[ \begin{array}{c} \text{Sum of} \\ \text{C score} \\ \text{Number of} \\ \text{hemisections} \end{array} \right] + \left[ \begin{array}{c} \text{Sum of} \\ \text{B score} \\ \text{Number of} \\ \text{hemisections} \end{array} \right]}{3}$$

A mean lesion score is calculated for each group of positive monkeys.

*Evaluation.* The comparison of the virus activity in the vaccine and the reference preparation is based on the activity in the lumbar enlargement of the cord and the degree of spread of activity from this region to the cervical enlargement and the brain. Acceptance or rejection is based on the total score of all the test animals. Individual animals showing evidence of unusually high activity, either in the lumbar region or as the result of spread from this region, are also taken into consideration in the final evaluation. The monovalent bulk passes the test if the required number of animals is positive and if none of the clinical and histopathological examinations shows a significant difference in pathogenicity between the vaccine virus and the reference material. Criteria for acceptance are given below.

*Criteria.* A suitable number of neurovirulence qualifying tests (for example, four tests) is carried out on each reference vaccine (types 1, 2 and 3) to provide data on the activity of such vaccines that will serve as the basis of the criteria for vaccines under test. The overall mean lesion score ( $M$ ) for the replicate tests on each reference virus is calculated together with the pooled estimate of the within-test variance ( $s^2$ ) and the within-test deviation ( $s$ ).

Validity criteria for the results of a test on a reference preparation are established on the basis of the cumulative data from the qualifying tests. No generally applicable criteria can be given; for laboratories with limited experience, the following empirical method for setting acceptable limits for the mean lesion score for the reference preparation ( $X_{\text{ref}}$ ) may be helpful.

If the mean lesion score for the vaccine under test is  $X_{\text{test}}$  and  $C_1$ ,  $C_2$  and  $C_3$  are constants determined as described below, then :

the vaccine is not acceptable if.

$$X_{\text{test}} - X_{\text{ref}} > C_1$$

the vaccine may be retested once if.

$$C_1 < X_{\text{test}} - X_{\text{ref}} < C_2$$

If the vaccine is retested, the means of the lesion scores for the vaccine under test and the reference vaccines are recalculated. The vaccine is not acceptable if :

$$\frac{X_{(\text{test}1 + \text{test}2)} - X_{(\text{ref}1 + \text{ref}2)}}{2} > C_3$$

The constants  $C_1$ ,  $C_2$  and  $C_3$  are calculated from the expressions.

$$C_1 = 2.3 \sqrt{\frac{2s^2}{N_1}}$$

$$C_2 = 2.6 \sqrt{\frac{2s^2}{N_1}}$$

$$C_3 = 1.6 \sqrt{\frac{2s^2}{N_1}}$$

where,  $N_1$  = number of positive monkeys per vaccine test,  
 $N_2$  = number of positive monkeys in the two tests,  
 2.3 = normal deviate at the 1.0 per cent level,  
 2.6 = normal deviate at the 0.5 per cent level,  
 1.6 = normal deviate at the 5.0 per cent level.

A neurovirulence test in which the mean lesion score for the reference ( $X_{ref}$ ) is not compatible with previous experience is not used for assessing a test vaccine. If the test is valid, the mean lesion score for the vaccine under test ( $X_{test}$ ) is calculated and compared with that of the homotypic reference vaccine.

### 2.7.7. Tests on Chicken Flocks free from Specified Pathogens for the Production and Quality Control of Vaccines

Where specified in a monograph, chickens, embryos or cell cultures used for the production or quality control of vaccines are derived from eggs produced by chicken flocks free from specified pathogens (SPF). The SPF status of a flock is ensured by means of the system described below. The list of micro-organisms given is based on current knowledge and will be updated periodically.

#### General principles and procedures

A flock is defined as a group of birds sharing a common environment and having their own caretakers who have no contact with non-SPF flocks. Once a flock is defined, no non-SPF birds are added to it.

For SPF flocks established on a rolling basis, all replacements are hatched and reared in the controlled environment house. Subject to the agreement of the competent authorities, SPF embryos derived from a tested SPF flock from another house on the same site may be introduced. From 8 weeks of age, these replacement birds are regarded as a flock and monitored monthly in accordance with the Subsequent testing requirements. At point of lay, all these replacement birds are tested in accordance with the Initial testing requirements.

The flock is housed so as to minimize the chance of contamination. It is not sited near to non-SPF flocks of birds and is housed in an isolator or on wire in a building with filtered air under positive pressure. Appropriate measures are taken to prevent access of rodents, wild birds, insects and unauthorized people.

Personnel authorized to enter must have no contact with other birds or with agents likely to infect the flock. It is advisable for personnel to shower and change clothing or to wear protective clothing before entering the chicken house.

Items taken into the flock are sterilised. The feed is suitably treated to avoid the introduction of undesirable micro-organisms and water is obtained from a chlorinated supply. No medication is given that could interfere with detection of disease in the flock.

A permanent record is kept of the general health of the flock and any abnormality is investigated. Factors to be monitored include morbidity, mortality, general physical condition, feed consumption, daily egg preparation and egg quality, fertility and hatchability. Dirty eggs are discarded; clean eggs may be surface-disinfected whilst warm.

The flock originates from chickens shown to be free from vertically-transmitted agents. In particular, each chicken from which the flock is derived is tested repeatedly to ensure freedom from leucosis viruses and their antibodies. In order to establish the SPF status of a flock, it is kept under SPF conditions for a test period of not less than 4 months. Each bird in the entire flock is shown to be free from evidence of infection with the agents listed in Table 1 under the heading initial testing after 6 weeks and at the end of the test period.

For each new generation in an established flock, all of the birds in the flock are tested at not later than 20 weeks of age, using the tests prescribed below under Initial testing. After the initial test, monthly tests are carried out on a representative 5 per cent sample (but not less than ten and not more than two hundred birds), using the tests prescribed in Table 2 under the heading Subsequent testing, with a final test at 4 weeks after the last collection of eggs.

Chickens used for testing of the vaccine should be shown to be free from antibodies (Table 3).

For all tests, blood samples are collected from an appropriate number of birds at the specified time. The resultant serum samples are examined for antibodies against the relevant agents. Serum-neutralization tests are done on pools of not more than five sera. All other tests are done on each individual serum. Positive and negative controls are used in all tests. The reagents used in the tests are standardized against international or any other validated standard reagents where these are available. For avian leucosis virus, in addition to tests for antibodies carried out on serum samples, appropriate samples are taken for testing for the virus.

In addition to serological tests, clinical examination is carried out at least once per week to verify that the birds are free from fowl-pox and signs of other infections. Necropsy and, where necessary to confirm diagnosis, histopathological examination are carried out on any bird that dies to verify that there is no sign of infection. The absence of *Salmonella* species is determined by cultural examination of faecal samples at least once every 4 weeks; a pool of up to ten samples may be used for the tests.

If a positive result is obtained in any test carried out to establish the SPF status of a flock, the flock may not be designated as an SPF flock. If a positive result is obtained in any test carried out on an established flock, the flock loses its SPF status. Special provisions apply to chick anemia agent (CAA) as described below. Any chickens, embryos or cell cultures collected since the previous negative test are not suitable for use: any preparation made from them must be discarded and any quality control tests done with them are invalid and must be repeated.

In order to regain SPF status, the flock is maintained under

SPF conditions and routine 5.0 per cent monthly testing shall continue except that every bird in the entire flock is tested every month for infection with the particular agent that gave the positive result. Infected birds and their progeny are removed from the flock. SPF status is regained after two such consecutive tests have yielded completely negative results.

A positive result for CAA does not necessarily exclude use of material derived from the flock, but live vaccines for use in birds less than 7 days old must be produced using material from CAA-negative flocks. Inactivated vaccines for use in birds less than 7 days old may be produced using material from flocks that have not been shown to be free from CAA, provided it has been demonstrated that the inactivation process inactivates CAA.

Permanent records of mortality and of results of flock testing are kept for a minimum of five years. Details of any deterioration in egg preparation or hatchability, except for accidental cases identified as being of non-infectious origin, and of any test results indicating infection with a specified agent, are immediately submitted to the user of the eggs.

Table 1 - **Initial Testing.** Subject to agreement by the competent authority, other types of test may be used provided they are at least as sensitive as those indicated and are of appropriate specificity.

Micro-organism	Type of test
Avian adenoviruses	Enzyme linked immunosorbent assay
Avian encephalomyelitis viruses	Enzyme linked immunosorbent assay
Avian infectious bronchitis virus	Enzyme linked immunosorbent assay
Avian infectious laryngo-tracheitis virus	Serum neutralization
Avian leucosis virus	Enzyme linked immunosorbent assay for virus and serum neutralization for antibody
Avian nephritis virus	Fluorescent antibody
Avian reoviruses	Enzyme linked immunosorbent assay
Avian reticuloendotheliosis virus	Fluorescent antibody
Haemagglutinating avian adenoviruses (egg drop syndrome 76 adenoviruses; EDS 76 virus)	Haemagglutination inhibition.
Infectious bursal disease virus	Serum neutralization against each serotype present in the country of origin
Influenza A virus	Enzyme linked immunosorbent assay
Marek's disease virus	Enzyme linked immunosorbent assay
Newcastle disease virus	Haemagglutination inhibition
Turkey rhinotracheitis virus	Enzyme linked immunosorbent assay
<i>Mycoplasma gallisepticum</i>	Agglutination and to confirm positive test
<i>Mycoplasma synoviae</i>	Haemagglutination inhibition Agglutination and, to confirm positive test haemagglutination inhibition
<i>Salmonella pullorum</i>	Agglutination

Table 2 - **Subsequent testing.** Subject to agreement by the competent authority, other types of test may be used provided they are at least as sensitive as those indicated and are of appropriate specificity.

Micro-organism	Type of test
Avian adenoviruses	Enzyme linked immunosorbent assay
Avian encephalomyelitis viruses	Enzyme linked immunosorbent assay
Avian infectious bronchitis virus	Enzyme linked immunosorbent assay
Avian infectious laryngo-tracheitis virus	Serum neutralization
Avian leucosis virus	Enzyme linked immunosorbent assay for virus and serum Neutralization for antibody
Avian nephritis virus	Flourescent antibody
Avian reoviruses	Enzyme linked immunosorbent assay
Avian reticuloendotheliosis virus	Fluorescent antibody
Chick anaemia agent	Fluorescent antibody.
Haemagglutinating avian adeno virus	Haemagglutination inhibition.
Infectious bursal disease virus	Serum neutralization against each serotype present in the country of origin
Influenza A virus	Enzyme linked immunosorbent assay
Marek's disease Virus	Enzyme linked immunosorbent assay
Newcastle disease virus	Haemagglutination inhibition
Turkey rhinotracheitis virus	Enzyme linked immunosorbent assay
<i>Mycoplasma gallisepticum</i>	Agglutination and, to confirm positive test
<i>Mycoplasma synoviae</i>	Haemagglutination inhibition Agglutination and, to confirm positive test haemagglutination inhibition
<i>Salmonella pullorum</i>	Agglutination

Table 3 - Monitoring for freedom from antibodies

Micro-organism	Type of test
Avian adenoviruses	Enzyme linked immunosorbent assay
Avian infectious bronchitis virus	Enzyme linked immunosorbent assay
Avian leucosis virus	Enzyme linked immunosorbent assay for virus and serum neutralization for antibody
Avian reoviruses	Enzyme linked immunosorbent assay
Chick anaemia agent	Fluorescent antibody.
Infectious bursal disease virus	Serum neutralization against each serotype present in the country of origin
Influenza A virus	Enzyme linked immunosorbent assay
Marek's disease virus	Enzyme linked immunosorbent assay
<i>Mycoplasma gallisepticum</i>	Agglutination and, to confirm positive test,
<i>Mycoplasma synoviae</i>	Haemagglutination inhibition Agglutination and, to confirm positive test haemagglutination inhibition
<i>Salmonella pullorum</i>	Agglutination



## 2.7.8. Test for Absence of Non-Avian Mycoplasmas and Ureaplasmas

### Culture media

Solid and liquid media suitable for sustaining the growth of a wide range of mycoplasmas are used. Each batch of media must be tested to show that it sustains the growth of *Mycoplasma hyopneumoniae* and *Ureaplasmas urealyticum*. For testing the media, the use of the low-passage strains is recommended.

No single medium may be satisfactory for optimal growth of the prescribed organisms. The solid and liquid media should be so selected that when used together they are capable of providing optimal growth condition for all likely contaminants. Liquid media should contain *phenol red*.

### Method

Performed the test in the presence and in the absence of the preparation under examination. The preparation under examination should be shown to be free of any inhibitory effect on the test organisms. If necessary, any inhibitory effect should be neutralized and tests carried out to confirm neutralization of the inhibitory effect.

The number of containers recommended to be drawn for the test is 1 per cent of a batch, with a minimum of three and maximum of ten. The contents of the containers of a liquid vaccine under examination should be mixed. For a dried vaccine, the contents should be mixed after reconstitution.

### Liquid media

Inoculate separately 50 ml of each medium with 5 ml of the test preparation under examination. If necessary after addition of the preparation under examination, the pH value of the liquid medium may be adjusted to the original value by the addition of sufficient 1M sodium hydroxide or 1M hydrochloric acid, as required. Incubate at 35° to 37° for 3 weeks observing three times a week.

Subculture by blind passage on the 3<sup>rd</sup>, 7<sup>th</sup> and 14<sup>th</sup> days after the beginning of incubation using an inoculum of 0.2 ml per agar plate of about 100 mm diameter. Observe the liquid media daily. If any colour change occurs, subculture immediately. If the culture in liquid medium shows bacterial or fungal contamination, repeat the test.

Using four plates for each subculture, incubate two of the plates at 35° to 37° under aerobic conditions in an atmosphere of air with high humidity and containing 5 to 10 per cent of carbon dioxide and the remaining two under anaerobic conditions in an atmosphere of nitrogen with high humidity and containing 5 to 10 per cent of carbon dioxide. Examine the plates regularly over a period of 3 weeks using a stereomicroscope. Stain if necessary with a suitable stain.

### Solid media

Inoculate each of four plates of medium with 0.2 ml of the test preparation under examination per agar plate of about 50 mm diameter. Incubate and examine the plates as described above.

If not more than one plate at each stage of the test is accidentally contaminated with bacteria or fungi, or broken, and this happens not earlier than 7 days after inoculation, that plate may be ignored provided that on immediate examination it shows no evidence of mycoplasmal growth. If, at any stage of the test, more than one plate is accidentally contaminated with bacteria or fungi, or broken, the test has to be repeated.

**Interpretation.** The vaccine passes the test if there is no evidence of contamination with mycoplasmas or ureaplasmas in the test using liquid media as well as in the test using solid media.

## 2.7.9. Test for Absence of Avian Mycoplasmas in Live Viral Poultry Vaccines

### Culture media

The solid and liquid media described here are used for the culture of most known mycoplasma species. The media selected must be tested at least to show that they sustain the growth of *Mycoplasma gallisepticum* (Medium A) and *Mycoplasma synoviae* (Medium B). For testing the media, the use of the low-passage strains is recommended.

No single medium may be satisfactory for optimal growth of the prescribed organisms. Media other than the ones recommended below may be used provided that it has been demonstrated that each batch is capable of sustaining the growth of mycoplasmas in the presence and absence of the vaccine under examination.

### A. Media recommended for the detection of *Mycoplasma gallisepticum*

#### Liquid medium

Beef heart infusion broth	900.0 ml
Horse serum (unheated)	20.0 ml
Yeast extract (25 per cent w/v)	10.0 ml
Thallium acetate (1 per cent w/v solution)	1.0 ml
Phenol red (0.06 per cent w/v solution)	5.0 ml
Benzylpenicillin potassium (or sodium) (1.2 per cent w/v solution)	0.25 ml
Deoxyribonucleic acid (0.2 per cent w/v solution)	1.2 ml
Mix and adjust to pH 7.8.	

**Solid medium**

Prepare as described above but replacing beef heart infusion broth by 1.5 per cent w/v of agar in beef heart infusion broth.

**Method**

Perform the test in the presence and in the absence of the preparation under examination. The preparation under examination should be shown to be free of any inhibitory effect on the test organisms. If necessary, any inhibitory effect should be neutralized and tests carried out to confirm neutralization of the inhibitory effect.

**Liquid Media**

Use at least two liquid media suitable for the growth of mycoplasmas and use adequate quantities of the vaccine under examination for each medium. For a freeze-dried vaccine, reconstitute the contents of 5 containers or 5,000 doses of vaccine, whichever is less, in 12 ml of the liquid stated on the label or another suitable liquid. This is referred to as the 'test preparation' hereafter. For a liquid vaccine use an equivalent quantity. Inoculate 100 ml of each medium with 10 ml of the test preparation. If necessary, after addition of the test preparation, pH of the medium may be adjusted to the original value by the addition of sufficient 1M sodium hydroxide or 1M hydrochloric acid, as required. Incubate at 35° to 37° for 3 weeks observing three times a week. Subculture by blind passage on the 3<sup>rd</sup>, 7<sup>th</sup> and 14<sup>th</sup> days after the beginning of incubation using an inoculum of 0.2 ml per agar plate of about 100 mm diameter. If any colour change occurs, subculture immediately. If the culture in liquid medium shows bacterial or fungal contamination, repeat the test.

Using four plates for each subculture, incubate two of the plates at 35° to 37° under aerobic conditions in an atmosphere of air with high humidity and containing 5 to 10 per cent of carbon dioxide and the remaining two under anaerobic conditions in an atmosphere of nitrogen with high humidity and containing 5 to 10 per cent of carbon dioxide. Examine the plates regularly over a period of 3 weeks using a stereomicroscope. Stain if necessary with a suitable stain and if growth occurs identify the isolate.

**Solid media**

Use at least two solid media suitable for the growth of mycoplasmas. Inoculate six plates of each medium with 0.2 ml of the test preparation described in the test with liquid media. Incubate and examine the plates as described above.

**Interpretation.** The vaccine passes the test if there is no evidence of contamination with mycoplasmas in the test using liquid media as well as in the test using solid media.

**B. Media recommended for the detection of *Mycoplasma synoviae*****Liquid medium**

Beef heart infusion broth	90.0 ml
Vitamin mixture	25.0 ml
Glucose (50 per cent w/v solution)	2.0 ml
Swine serum (inactivated at 56° for 30 minutes)	12.0 ml
β-Nicotinamide adenine dinucleotide (1 per cent w/v solution)	1.0 ml
Cysteine hydrochloride (1 per cent w/v solution)	1.0 ml
Phenol red (0.06 per cent w/w solution)	5.0 ml
Benzyl penicillin potassium (or sodium) (1.2 per cent w/v solution)	0.25 ml

Mix the solution of β-nicotinamide adenine dinucleotide and cysteine hydrochloride. After 10 minutes add the other ingredients. Mix and adjust to pH 7.8.

**Solid medium**

Beef heart infusion broth	90.0 ml
Ionagar	1.4 g
Vitamin mixture	0.025 ml
Glucose (50 per cent w/v solution)	2.0 ml
Swine serum (unheated)	12.0 ml
β-Nicotinamide adenine dinucleotide (1 per cent w/v solution)	1.0 ml
Cysteine hydrochloride (1 per cent w/v solution)	1.0 ml
Phenol red (0.06 per cent w/v solution)	5.0 ml
Benzyl penicillin potassium (or sodium) (1.2 per cent w/v solution)	0.25 ml

Mix beef heart infusion broth and ionagar, adjust to pH 7.8 and sterilize by autoclaving. Add the other ingredients to the mixture.

**Special Reagents****Beef heart infusion broth**

Beef heart (for preparation of the infusion)	500 g
Peptone	10 g
Sodium chloride	5 g
Distilled water	1000 ml

**Vitamin mixture**

Biotin	100 mg
Calcium pantothenate	100 mg
Choline chloride	100 mg
Folic acid	100 mg
Myo-Inositol	200 mg
Nicotinamide	100 mg
Pyridoxine hydrochloride	100 mg
Riboflavin	10 mg
Thiamine hydrochloride	100 mg
Distilled water	1000 ml

**Ionagar**

A highly refined agar for use in microbiology and immunology prepared by an ion-exchange procedure which results in a product having superior purity, clarity and gel strength.

It contains approximately:

Water	2.20 per cent
Ash	1.50 per cent
Acid-insoluble ash	0.20 per cent
Chlorine	None
Phosphate (calculated as P <sub>2</sub> O <sub>5</sub> )	0.30 per cent
Total nitrogen	0.30 per cent
Copper	8 ppm
Iron	170 ppm
Calcium	0.28 per cent
Magnesium	0.32 per cent

**2.7.10. Avian Viral Vaccines - Tests for Extraneous Agents in Seed Lot**

- In the following tests, chickens and/or chicken material such as eggs and cell cultures shall be derived from chicken flocks free from specified pathogens (SPF) (2.7.7)
- Cell cultures for the testing of extraneous agents comply with the requirements for the master cell seed of cell cultures for the production of veterinary vaccines, with the exception of the karyotype test and the tumorigenicity test, which do not have to be carried out.
- In tests using cell cultures, precise specifications are given for the number of replicates, monolayer surface areas and minimum survival rate of the cultures. Alternative numbers of replicates and cell surface areas are possible as well, provided that a minimum of 2 replicates are used, the total surface area and the total volume of test substance applied are not less than that prescribed

here and the survival rate requirements are adapted accordingly.

- For a freeze-dried preparation, reconstitute using a suitable liquid. Unless otherwise stated or justified, the test substance must contain a quantity of virus equivalent to at least 10 doses of vaccine in 0.1 ml of inoculum.
- If the virus of the seed lot would interfere with the conduct and sensitivity of the test, neutralise the virus in the preparation with a monospecific antiserum.
- Monospecific antiserum and serum of avian origin used for cell culture or any other purpose, in any of these tests, shall be free of antibodies against and free from inhibitory effects on the organisms listed here after under 7. Antibody specifications for sera used in extraneous agents testing.
- Where specified in a monograph or otherwise justified, if neutralization of the virus of the seed lot is required but difficult to achieve, the *in vitro* tests described below are adapted, as required, to provide the necessary guarantees of freedom from contamination with an extraneous agent.
- Other types of tests than those indicated may be used provided they are at least as sensitive as those indicated and of appropriate specificity. Nucleic acid amplification techniques (2.8.1) give specific detection for many agents and can be used after validation for sensitivity and specificity.

**1. Test for extraneous agents using embryonated hens' eggs**

Use a test substance, diluted if necessary containing a quantity of neutralised virus equivalent to at least 10 doses of vaccine in 0.2 ml of inoculum. Suitable antibiotics may be added. Inoculate the test substance into 3 groups of 10 embryonated hens' eggs as follows:

Group 1: 0.2 ml into the allantoic cavity of each 9 to 11 day-old embryonated egg;

Group 2: 0.2 ml onto the chorio-allantoic membrane of each 9 to 11 day-old embryonated egg;

Group 3: 0.2 ml into the yolk sac of each 5 to 6 day-old embryonated egg.

Candle the eggs in groups 1 and 2 daily for 7 days and the eggs in group 3 for 12 days. Discard embryos that die during the first 24 hours as non-specific deaths; the test is not valid unless at least 6 embryos in each group survive beyond the first 24 h after inoculation. Examine macroscopically for abnormalities in all embryos which die 24 hours after inoculation, or which survive the incubation period.

Examine also the chorio-allantoic membranes of these eggs for any abnormality and test the allantoic fluids for the presence of haemagglutinating agents.

Carry out a further embryo passage. Pool separately material from live and from the dead and abnormal embryos. Inoculate each pool into 10 eggs for each route as described above, chorio-allantoic membrane material being inoculated onto chorio-allantoic membranes, allantoic fluids into the allantoic cavity and embryo material into the yolk sac. For eggs inoculated by the allantoic and chorio-allantoic routes, candle the eggs daily for 7 days, proceeding and examining the material as described above. For eggs inoculated by the yolk sac route, candle the eggs daily for 12 days, proceeding and examining the material as described above.

The seed lot complies with the test if no test embryo shows macroscopic abnormalities or dies from causes attributable to the seed lot and if examination of the chorio-allantoic membranes and testing of the allantoic fluids show no evidence of the presence of any extraneous agent.

## 2. Test in chicken kidney cells

Prepare 7 monolayers of chicken kidney cells, each monolayer having an area of about 25 cm<sup>2</sup>. Maintain 2 monolayers as negative controls and treat these in the same way as the 5 monolayers inoculated with the test substance, as described below.

Remove the culture medium when the cells reach confluence. Inoculate 0.1 ml of test substance onto each of the 5 monolayers. Allow adsorption for 1 h, add culture medium and incubate the cultures for a total of at least 21 days, subculturing at 4 to 7 day intervals. Each passage is made with pooled cells and fluids from all 5 monolayers after carrying out a freeze-thaw cycle.

Inoculate 0.1 ml of pooled material onto each of 5 recently prepared monolayers of about 25 cm<sup>2</sup> each, at each passage. For the last subculture, grow the cells also on a suitable substrate so as to obtain an area of about 10 cm<sup>2</sup> of cells from each of the monolayers for test A. The test is not valid if less than 80 per cent of the monolayer survives after any passage.

Examine microscopically all the cell cultures frequently throughout the entire incubation period for any signs of cytopathic effect or other evidence of the presence of contaminating agents in the test substance. At the end of the total incubation period, carry out the following procedures.

**Test A.** Fix and stain (with Giemsa or haematoxylin and eosin) about 10 cm<sup>2</sup> of confluent cells from each of the 5 monolayers. Examine the cells microscopically for any cytopathic effect, inclusion bodies, syncytial formation or any other evidence of the presence of contaminating agents from the test substance.

**Test B.** Drain and wash about 25 cm<sup>2</sup> of cells from each of the 5 monolayers. Cover these cells with a 0.5 per cent suspension of washed chicken erythrocytes (using 1 ml of suspension for each 5 cm<sup>2</sup> of cells).

Incubate the cells at 4° for 20 minutes and then wash gently in *phosphate buffered saline pH 7.4*. Examine the cells microscopically for haemadsorption attributable to the presence of a haemadsorbing agent in the test substance.

**Test C.** Test pooled cell culture fluids using chicken erythrocytes for haemagglutination attributable to the presence of a haemagglutinating agent in the test substance.

The test is not valid if there are any signs of extraneous agents in the negative control cultures. The seed lot complies with the test if there is no evidence of the presence of any extraneous agent.

## 3. Test for avian leucosis viruses

Prepare at least 13 replicate monolayers of primary or secondary chick embryo fibroblasts from the tissues of 9 to 11 day-old embryos that are known to be genetically susceptible to subgroups A, B and J of avian leucosis viruses and that support the growth of exogenous but not endogenous avian leucosis viruses (cells from C/E strain chickens are suitable). Each replicate shall have an area of about 50 cm<sup>2</sup>.

Remove the culture medium when the cells reach confluence.

Inoculate 0.1 ml of the test substance onto each of 5 of the replicate monolayers. Allow adsorption for 1 hour, and add culture medium. Inoculate 2 of the replicate monolayers with subgroup A avian leucosis virus (not more than 10 CCID<sub>50</sub> in 0.1 ml), 2 with subgroup B avian leucosis virus (not more than 10 CCID<sub>50</sub> in 0.1 ml) and 2 with subgroup J avian leucosis virus (not more than 10 CCID<sub>50</sub> in 0.1 ml) as positive controls. Maintain not less than 2 non-inoculated replicate monolayers as negative controls.

Incubate the cells for a total period of 9 days, subculturing at 3 to 4 day intervals. Retain cells from each passage level and harvest the cells at the end of the total incubation period. Wash cells from each passage level from each replicate and resuspend the cells at 10<sup>7</sup> cells per ml in *barbital-buffered saline* for subsequent testing by a Complement Fixation for Avian Leucosis (COFAL) test or in *phosphate buffered saline* for testing by Enzyme-Linked Immunosorbent Assay (ELISA). Then, carry out 3 cycles of freezing and thawing to release any group-specific antigen and perform a COFAL test or an ELISA test on each extract to detect group-specific avian leucosis antigen if present.

The test is not valid if group-specific antigen is detected in less than 5 of the 6 positive control replicate monolayers or if a positive result is obtained in any of the negative control monolayers, or if the results for both of the 2 negative control monolayers are inconclusive. If the results for more than 1 of the test replicate monolayers are inconclusive, then further subcultures of reserved portions of the fibroblast monolayers shall be made and tested until an unequivocal result is obtained.



If a positive result is obtained for any of the test monolayers, then the presence of avian leucosis virus in the test substance has been detected.

The seed lot complies with the test if there is no evidence of the presence of any avian leucosis virus.

#### 4. Test for avian reticuloendotheliosis virus

Prepare 11 monolayers of primary or secondary chick embryo fibroblasts from the tissues of 9 to 11 day-old chick embryos or duck embryofibroblasts from the tissues of 9 to 11 day-old embryos, each monolayer having an area of about 25 cm<sup>2</sup>.

Remove the culture medium when the cells reach confluence. Inoculate 0.1 ml of the test substance onto each of 5 of the monolayers. Allow adsorption for 1 hour and add culture medium. Inoculate 4 of the monolayers with avian eticuloendotheliosis virus as positive controls (not more than 10 CCID<sub>50</sub> in 0.1 ml). Maintain 2 non-inoculated monolayers as negative controls.

Incubate the cells for a total of 10 days, subculturing twice at 3 to 4 day intervals. The test is not valid if less than 3 of the 4 positive controls or less than 4 of the 5 test monolayers or neither of the 2 negative controls survive after any passage.

For the last subculture, grow the fibroblasts on a suitable substrate so as to obtain an area of about 10 cm<sup>2</sup> of confluent fibroblasts from each of the original 11 monolayers for the subsequent test: test about 10 cm<sup>2</sup> of confluent fibroblasts derived from each of the original 11 monolayers by immunostaining for the presence of avian reticuloendotheliosis virus. The test is not valid if avian reticuloendotheliosis virus is detected in less than 3 of the 4 positive control monolayers or in any of the negative control monolayers, or if the results for both of the 2 negative control monolayers are inconclusive. If the results for more than 1 of the test mono layers are inconclusive then further subcultures of reserved portions of the fibroblast monolayers shall be made and tested until an unequivocal result is obtained.

The seed lot complies with the test if there is no evidence of the presence of avian reticuloendotheliosis virus.

#### 5. Test for chicken anaemia virus

Prepare eleven 20 ml suspensions of the MDCC-MSBI cell line or another cell line of equivalent sensitivity in 25 ml cell culture flasks containing about 5 x 10<sup>5</sup> cells per ml. Inoculate 0.1 ml of test substance into each of 5 flasks. Inoculate 4 of the suspensions with 10 CCID<sub>50</sub> chicken anaemia virus as positive controls. Maintain not less than 2 non-inoculated suspensions. Maintain all the cell cultures for a total of at least 24 days, subculturing 8 times at 3 to 4 day intervals.

During the subculturing the presence of chicken anaemia virus may be indicated by a metabolic colour change in the infected

cultures, the culture fluids become red in comparison with the control cultures. Examine the cells microscopically for cytopathic effect. At this time or at the end of the incubation period, centrifuge the cells from each flask at low speed and resuspend at about 5 x 10<sup>5</sup> cells per ml and place 25 ml in each of 10 wells of a multi-well slide. Examine the cells by immunostaining.

The test is not valid if chicken anaemia virus is detected in less than 3 of the 4 positive controls or in any of the non-inoculated controls. If the results for more than 1 of the test suspensions are inconclusive, then further subcultures of reserved portions of the test suspensions shall be made and tested until an unequivocal result is obtained.

The seed lot complies with the test if there is no evidence of the presence of chicken anaemia virus.

#### 6. Test for extraneous agents using chicks

Inoculate each of at least 10 chicks, with the equivalent of 100 doses of vaccine by the intramuscular route and with the equivalent of 10 doses by eye-drop. Chicks that are 2 weeks of age are used in the test except that if the seed virus is pathogenic for birds of this age, older birds may be used, if required and justified. In exceptional cases, for inactivated vaccines, the virus may be neutralized by specific antiserum if the seed virus is pathogenic for birds at the age of administration. Repeat these inoculations 2 weeks later. Observe the chicks for a period of 5 weeks from the day of the first inoculation. No antimicrobial agents shall be administered to the chicks during the test period. The test is not valid if less than 80 per cent of the chicks survive to the end of the test period.

Collect serum from each chick at the end of the test period. Test each serum sample for antibodies against each of the agents listed below (with the exception of the virus type of the seed lot) using one of the methods indicated for testing for the agent.

##### A. Standard test

Agent	Type of Test
Avian adenoviruses, group	1 SN, EIA, AGP
Avian encephalomyelitis virus	AGP, EIA
Avian infectious bronchitis virus	EIA, HI
Avian infectious laryngotracheitis virus	SN, EIA, IS
Avian leucosis viruses	SN, EIA, IS
Avian nephritis virus	IS
Avian reoviruses	IS, EIA
Avian reticuloendotheliosis virus	AGP, IS, EIA
Chicken anaemia virus	IS, EIA, SN
Egg drop syndrome virus	HI, EIA

Infectious bursal disease virus	GP, EIA	The seed lot complies with the test if there is no evidence of the presence of any extraneous agent.
Influenza A virus	AGP, EIA	
Marek's disease virus	AGP	The test is not valid if antibodies are detected in the chicks to any of the test agents before inoculation.
Newcastle disease virus	HI, EIA	
Turkey rhinotracheitis virus	EIA	Clinical signs of disease in the chicks during the test period (other than signs attributable to the virus of the seed lot) and the detection of antibodies in the chicks after inoculation, (with the exception of antibodies to the virus of the seed lot) are classed as evidence of the presence of an extraneous agent in the seed lot.
<i>Mycoplasma gallisepticum</i>	Agg and to confirm positive test HI	
<i>Mycoplasma synovial</i>	Agg and to confirm positive test HI	It is recommended that sera from these birds is retained so that additional testing may be carried out if requirements change.
<i>Salmonella pullorum</i>	Agg	

Agg	:	agglutination
AGP	:	agar gel precipitation
EIA	:	enzyme immunoassay (e.g. ELISA)
IS	:	immunostaining (e.g. fluorescent antibody)
HI	:	haemagglutination inhibition
SN	:	serum neutralisation

### B. Additional tests for turkey extraneous agents

If the seed virus is of turkey origin or was propagated in turkey substrates, tests for antibodies against the following agents are also carried out.

Agent	Type of test
<i>Chlamydia</i> spp.	EIA
Avian infectious haemorrhagic enteritis virus	AGP
Avian paramyxovirus 3	HI
Avian infectious bursal disease virus type 2	SN

A test for freedom from turkey lympho-proliferative disease virus is carried out by intraperitoneal inoculation of twenty 4-week-old turkey poults. Observe the poults for 40 days. The test is not valid if more than 20 per cent of the poults die from non-specific causes. The seed lot complies with the test if sections of spleen and thymus taken from 10 poults 2 weeks after inoculation show no macroscopic or microscopic lesions (other than those attributable to the seed lot virus) and no poult dies from causes attributable to the seed lot.

### C. Additional tests for duck extraneous agents

If the seed virus is of duck origin or was propagated in duck substrates. Tests for antibodies against the following agents are also carried out.

Agent	Type of test
<i>Chlamydia</i> spp.	EIA
Duck and Goose parvoviruses	SN
Duck enteritis virus	SN
Duck hepatitis virus type I	SN

### 7. Antibody specifications for sera used in extraneous agents testing

All batches of serum to be used in extraneous agents testing either to neutralise the vaccine virus (seed lot or batch of finished product) or all batches of avian serum used as a supplement for culture media used for tissue culture propagation, shall be shown to be free of antibodies against and free from inhibitory effects on the following micro-organisms by suitably sensitive tests:

Avian adenoviruses  
 Avian encephalomyelitis virus  
 Avian infectious bronchitis viruses  
 Avian infectious bursal disease virus types 1 and 2  
 Avian infectious haemorrhagic enteritis virus  
 Avian infectious laryngotracheitis virus  
 Avian leucosis viruses  
 Avian nephritis virus  
 Avian paramyxoviruses 1 to 9  
 Avian reoviruses  
 Avian reticuloendotheliosis virus  
 Chicken anaemia virus  
 Duck enteritis virus  
 Duck hepatitis virus type I  
 Egg drop syndrome virus  
 Fowl pox virus  
 Influenza viruses  
 Marek's disease virus  
 Turkey herpesvirus  
 Turkey rhinotracheitis virus

Non-immune serum for addition to culture media can be assumed to be free of antibodies against any of these viruses if the agent is known not to infect the species of origin of the

serum and it is not necessary to test the serum for such antibodies. Monospecific antisera for virus neutralisation can be assumed to be free of the antibodies against any of these viruses if it can be shown that the immunising antigen could not have been contaminated with antigens derived from that virus and if the virus is known not to infect the species of origin of the serum; it is not necessary to test the serum for such antibodies. It is not necessary to retest sera obtained from birds from SPF chicken flocks (2.7.7).

Batches of sera prepared for neutralising the vaccine virus must be prepared from any passage level derived from the virus isolate used to prepare the master seed lot or from an isolate cultured in the same cell line.

### 2.7.11. Avian Live Virus Vaccines - Tests for Extraneous Agents in Batches of Finished Products

In the following tests, chickens and/or chicken material such as eggs and cell cultures shall be derived from chicken flocks free from specified pathogens (SPF) (2.7.7).

- a) Cell cultures for the testing of extraneous agents comply with the requirements for the master cell seed of cell cultures for the production of veterinary vaccines with the exception of the karyotype test and the tumorigenicity test which do not have to be carried out.
- b) In tests using cell cultures, precise specifications are given for the number of replicates, monolayer surface areas and minimum survival rate of the cultures. Alternative numbers of replicates and cell surface areas are possible as well, provided that a minimum of 2 replicates are used, the total surface area and the total volume of vaccine test applied are not less than that prescribed here and the survival rate requirements are adapted accordingly.
- c) In these tests, use the liquid vaccine or reconstitute a quantity of the freeze-dried preparation under test with the liquid stated on the label or another suitable diluent such as *water for injections*. Unless otherwise stated or justified, the test substance contains the equivalent of 10 doses in 0.1 ml of inoculum.
- d) If the vaccine virus would interfere with the conduct and sensitivity of the test, neutralize the virus in the preparation with a monospecific antiserum.
- e) Where specified in a monograph or otherwise justified, if neutralization of the vaccine virus is required but difficult to achieve, the *in vitro* tests described below are adapted, as required, to provide the necessary guarantees of freedom from contamination with an extraneous agent. Alternatively, or in addition to *in vitro* tests conducted

on the batch, a test for extraneous agents may be conducted on chick sera obtained from testing the batch of vaccine, as described under 6. Test for extraneous agents using chicks of chapter (2.7.10).

- f) Monospecific antiserum and serum of avian origin used for cell culture and any other purpose, in any of these tests, shall be free of antibodies against and free from inhibitory effects on the organisms listed under 7. Antibody specifications for sera used in extraneous agents testing (2.7.10).
- g) Other types of tests than those indicated may be used provided they are at least as sensitive as those indicated and of appropriate specificity. Nucleic acid amplification techniques (2.8.1) give specific detection for many agents and can be used after validation for sensitivity and specificity.

#### 1. Test for extraneous agents using embryonated hens' eggs

Prepare the test vaccine, diluted if necessary, to contain neutralised virus equivalent to 10 doses of vaccine in 0.2 ml of inoculum. Suitable antibiotics may be added. Inoculate the test vaccine into 3 groups of 10 embryonated hens' eggs as follows:

Group 1: 0.2 ml into the allantoic cavity of each 9 to 11 day-old embryonated egg;

Group 2: 0.2 ml onto the chorio-allantoic membrane of each 9 to 11 day-old embryonated egg;

Group 3: 0.2 ml into the yolk sac of each 5 to 6 day-old embryonated egg.

Candle the eggs in groups 1 and 2 daily for 7 days and the eggs in group 3 for 12 days. Discard embryos that die during the first 24 hours as non-specific deaths; the test is not valid unless at least 6 embryos in each group survive beyond the first 24 hours after inoculation. Examine macroscopically for abnormalities all embryos which die more than 24 hours after inoculation, or which survive the incubation period.

Examine also the chorio-allantoic membranes of these eggs for any abnormality and test the allantoic fluids for the presence of haemagglutinating agents.

Carry out a further embryo passage. Pool separately material from live and from the dead and abnormal embryos.

Inoculate each pool into 10 eggs for each route as described above, chorio-allantoic membrane material being inoculated onto chorio-allantoic membranes, allantoic fluids into the allantoic cavity and embryo material into the yolk sac. For eggs inoculated by the allantoic and chorio-allantoic routes, candle the eggs daily for 7 days, proceeding and examining the material as described above. For eggs inoculated by the yolk sac route, candle the eggs daily for 12 days, proceeding and examining the material as described above.

The batch of vaccine complies with the test if no test embryo shows macroscopic abnormalities or dies from causes attributable to the vaccine and if examination of the chorio-allantoic membranes and testing of the allantoic fluids show no evidence of the presence of extraneous agents.

## 2. Test in chicken embryo fibroblast cells

Prepare 7 monolayers of primary or secondary chicken embryo fibroblasts, from the tissues of 9 to 11 day-old embryos, each monolayer having an area of about 25 cm<sup>2</sup>. Maintain 2 monolayers as negative controls and treat these in the same way as the 5 monolayers inoculated with the test vaccine, as described below.

Remove the culture medium when the cells reach confluence. Inoculate 0.1 ml of test vaccine onto each of 5 of the monolayers. Allow adsorption for 1 h and add culture medium. Incubate at 37° the cultures for a total of at least 21 days, subculturing at 4 to 5 day intervals. Each passage is made with pooled cells and fluids from all 5 monolayers after carrying out a freeze-thaw cycle.

Inoculate 0.1 ml of pooled material onto each of 5 recently prepared monolayers of chicken embryo fibroblast cells, each monolayer having an area of about 25 cm<sup>2</sup> each as before.

For the last subculture, grow the cells also on a suitable substrate so as to obtain an area of about 10 cm<sup>2</sup> of cells from each of the monolayers, for test A. The test is not valid if less than 80 per cent of the test monolayers, or neither of the 2 negative control monolayers survive after any passage.

Examine microscopically all the cell cultures frequently throughout the entire incubation period for any signs of cytopathic effect or other evidence of the presence of contaminating agents in the test vaccine. At the end of the total incubation period, carry out the following procedures.

A. Fix and stain (with *Giemsa* or *Haematoxylin* and *Eosin*) about 10 cm<sup>2</sup> of confluent cells from each of the 5 original monolayers. Examine the cells microscopically for any cytopathic effect, inclusion bodies, syncytial formation, or any other evidence of the presence of a contaminating agent from the test vaccine.

B. Drain and wash about 25 cm<sup>2</sup> of cells from each of the 5 monolayers. Cover these cells with a 0.5 per cent suspension of washed chicken red blood cells (using at least 1 ml of suspension for each 5 cm<sup>2</sup> of cells). Incubate the cells at 4° for 20 minutes and then wash gently in *phosphate buffered saline pH 7.4*. Examine the cells microscopically for haemadsorption attributable to the presence of a haemadsorbing agent in the test vaccine.

C. Test pooled cell culture fluids using chicken red blood cells for haemagglutination attributable to the presence of a haemagglutinating agent in the test vaccine.

The test is not valid if there are any signs of extraneous agents in the negative control cultures. The batch of vaccine complies with the test if there is no evidence of the presence of any extraneous agent.

## 3. Test for egg drop syndrome virus

Prepare 11 monolayers of chicken embryo liver cells, from the tissues of 14 to 16 day-old embryos, each monolayer having an area of about 25 cm<sup>2</sup>. Remove the culture medium when the cells reach confluence. Inoculate 0.1 ml of test vaccine onto each of 5 of the monolayers (test monolayers).

Allow adsorption for 1 hours at 37°, add culture medium. Inoculate 4 of the monolayers with a suitable strain of egg drop syndrome virus (not more than 10 CCID<sub>50</sub> in 0.1 ml to serve as positive control monolayers. Maintain 2 non-inoculated monolayers as negative control monolayers.

Incubate the cells for a total of at least 21 days, subculturing every 4 to 5 days. Each passage is made as follows: Carry out a freeze-thaw cycle; prepare separate pools of the cells plus fluid from the test monolayers, from the positive control monolayers and from the negative control monolayers; Inoculate 0.1 ml of the pooled material onto each of 5, 4 and 2 recently prepared monolayers of chicken embryo liver cells, each monolayer having an area of about 25 cm<sup>2</sup> as before. The test is not valid if less than 4 of the 5 test monolayers or less than 3 of the 4 positive controls or neither of the 2 negative control monolayers survive after any passage.

Examine microscopically all the cell cultures at frequent intervals throughout the entire incubation period for any signs of cytopathic effect or other evidence of the presence of a contaminating agent in the test vaccine. At the end of the total incubation period, carry out the following procedure.

Test separately, cell culture fluid from the test monolayers, positive control monolayers and negative control monolayers, using chicken red blood cells, for haemagglutination attributable to the presence of haemagglutinating agents.

The test is not valid if egg drop syndrome virus is detected in less than 3 of the 4 positive control monolayers or in any of the negative control monolayers or if the results for both of the 2 negative control monolayers are inconclusive.

If the results for more than one of the test monolayers are inconclusive then further subcultures of reserved portions of the monolayers shall be made and tested until an unequivocal result is obtained.

The batch of vaccine complies with the test if there is no evidence of the presence of egg drop syndrome virus or any other extraneous agent.

## 4. Test for Marek's disease virus

Prepare 11 monolayers of primary or secondary chick embryo fibroblasts from the tissues of 9 to 11 day old embryos, each



monolayer having an area of about 25 cm<sup>2</sup>. Remove the culture medium when the cells reach confluence.

Inoculate 0.1 ml of test vaccine onto each of 5 of the monolayers (test mono layers). Allow adsorption for 1 h, and add culture medium. Inoculate 4 of the monolayers with a suitable strain of Marek's disease virus (not more than 10 CCID<sub>50</sub> in 0.1 ml) to serve as positive controls. Maintain 2 non-inoculated monolayers as negative controls.

Incubate the cultures for a total of 21 days, subculturing at 4 to 5 day intervals. Each passage is made as follows:

Trypsinise the cells, prepare separate pools of the cells from the test monolayers, from the positive control monolayers and from the negative control monolayers. Mix an appropriate quantity of each with a suspension of freshly prepared primary or secondary chick embryo fibroblasts and prepare 5, 4 and 2 monolayers, as before. The test is not valid if less than 4 of the 5 test monolayers or less than 3 of the 4 positive controls or neither of the 2 negative control monolayers survive after any passage.

Examine microscopically all the cell cultures frequently throughout the entire incubation period for any signs of cytopathic effect or other evidence of the presence of a contaminating agent in the test vaccine.

For the last subculture, grow the cells on a suitable substrate so as to obtain an area of about 25 cm<sup>2</sup> of confluent cells from each of the original 11 monolayers for the subsequent test: test about 10 cm<sup>2</sup> of confluent cells derived from each of the original 11 monolayers by immunostaining for the presence of Marek's disease virus. The test is not valid if Marek's disease virus is detected in less than 3 of the 4 positive control monolayers or in any of the negative control monolayers, or if the results for both of the 2 negative control monolayers are inconclusive.

The batch of vaccine complies with the test if there is no evidence of the presence of Marek's disease virus or any other extraneous agent.

## 5. Tests for turkey rhinotracheitis virus

### A. In chicken embryo fibroblasts

*NOTE. This test can be combined with Test 2 by using the same test monolayers and negative controls, for all stages up to the final specific test for turkey rhinotracheitis virus on cells prepared from the last subculture.*

Prepare 11 monolayers of primary or secondary chick embryo fibroblasts from the tissues of 9 to 11day-old embryos, each monolayer having an area of about 25 cm<sup>2</sup>. Remove the culture medium when the cells reach confluence. Inoculate 0.1 ml of test vaccine onto each of 5 of the monolayers (test monolayers). Allow adsorption for 1 hour at 37°, and add culture medium.

Inoculate 4 of the monolayers with a suitable strain of turkey rhinotracheitis virus as positive controls (not more than 10 CCID<sub>50</sub> in 0.1 ml). Maintain 2 non-inoculated monolayers as negative controls. .

Incubate the cultures for a total of at least 21 days, subculturing at 4 to 5 day intervals. Each passage is made as follows:

Carry out a freeze-thaw cycle; prepare separate pools of the cells plus fluid from the test monolayers, from the positive control monolayers and from the negative control monolayers inoculate 0.1 ml of the pooled material onto each of 5, 4 and 2 recently prepared monolayers of chicken embryo fibroblasts cells, each monolayer having an area of about 25 cm<sup>2</sup> as before. The test is not valid if less than 4 of the 5 test monolayers or less than 3 of the 4 positive controls or neither of the 2 negative control monolayers survive after any passage.

For the last subculture, grow the cells on a suitable substrate so as to obtain an area of about 10 cm<sup>2</sup> of confluent cells from each of the original 11 monolayers for the subsequent test: test about 10 cm<sup>2</sup> of confluent cells derived from each of the original 11 monolayers by immunostaining for the presence of turkey rhinotracheitis virus. The test is not valid if turkey rhinotracheitis virus is detected in less than 3 of the 4 positive control monolayers or in any of the negative control monolayers or if the results for both of the 2 negative control monolayers are inconclusive. If the results for both of the two test monolayers are inconclusive then further subcultures of reserved portions of the fibroblasts shall be made and tested until an unequivocal result is obtained.

The batch of vaccine complies with the test if there is no evidence of the presence of turkey rhinotracheitis virus or any other extraneous agent.

### B. In vero cells

Prepare 11 monolayers of Vero cells, each monolayer having an area of about 25 cm<sup>2</sup>. Remove the culture medium when the cells reach confluence. Inoculate 0.1 ml of test vaccine onto each of 5 of the monolayers (test monolayers). Allow adsorption for 1 hour at 37°, and add culture medium. Inoculate 4 of the monolayers with a suitable strain of turkey rhinotracheitis virus (not more than 10 CCID<sub>50</sub> in 0.1 ml) to serve as positive controls. Maintain 2 non-inoculated monolayers as negative controls.

Incubate at 37° the cultures for a total of at least 21 days, subculturing at 4 to 5 day intervals. Each passage is made as follows:

Carry out a freeze-thaw cycle. Prepare separate pools of the cells plus fluid from the test monolayers, from the positive control monolayers and from the negative control monolayers. Inoculate 0.1 ml of the pooled material onto each of 5, 4 and 2 recently prepared monolayers of Vero cells, each monolayer

having an area of about 25 cm<sup>2</sup> as before. The test is not valid if less than 4 of the 5 test monolayers or less than 3 of the 4 positive controls or neither of the 2 negative controls survive after any passage.

For the last subculture, grow the cells on a suitable substrate so as to obtain an area of about 10 cm<sup>2</sup> of confluent cells from each of the original 11 monolayers for the subsequent test. Test about 10 cm<sup>2</sup> of confluent cells derived from each of the original 11 monolayers by immunostaining for the presence of turkey rhinotracheitis virus. The test is not valid if turkey rhinotracheitis virus is detected in less than 3 of the 4 positive control monolayers or in any of the negative control monolayers, or if the results for both of the 2 negative control monolayers are inconclusive. If the results for more than 1 of the test monolayers are inconclusive then further subcultures of reserved portions of the monolayers shall be made and tested until an unequivocal result is obtained.

The batch of vaccine complies with the test if there is no evidence of the presence of turkey rhinotracheitis virus or any other extraneous agent.

#### **6. Test for chicken anaemia virus**

Prepare eleven 20 ml suspensions of the MDCC-MSBI cell line or another cell line of equivalent sensitivity in 25 ml flasks containing about 5 x 10<sup>5</sup> cells per ml. Inoculate 0.1 ml of test vaccine into each of 5 of these flasks. Inoculate 4 other suspensions with 10 CCID<sub>50</sub> chicken anaemia virus as positive controls. Maintain not less than 2 non-inoculated suspensions. Maintain all the cell cultures for a total of at least 24 days, subculturing 8 times at 3 to 4 day intervals.

During the subculturing the presence of chicken anaemia virus may be indicated by a metabolic colour change in the infected cultures, the culture fluids becoming red in comparison with the control cultures. Examine the cells microscopically for cytopathic effect. At this time or at the end of the incubation period, centrifuge the cells from each flask at low speed, resuspend at about 10<sup>6</sup> cells per ml and place 25 µl in each of 10 wells of a multi-well slide. Examine the cells by immunostaining.

The test is not valid if chicken anaemia virus is detected in less than 3 of the 4 positive controls or in any of the non-inoculated controls. If the results for more than 1 of the test suspensions are inconclusive then further subcultures of reserved portions of the test suspensions shall be made and tested until an unequivocal result is obtained. The batch of vaccine complies with the test if there is no evidence of the presence of chicken anaemia virus.

#### **7. Test for duck enteritis virus**

This test is carried out for vaccines prepared on duck or goose substrates. Prepare 11 monolayers of primary or secondary

Muscovy duck embryo liver cells, from the tissues of 21 or 22 day-old embryos, each monolayer having an area of about 25 cm<sup>2</sup>. Remove the culture medium when the cells reach confluence.

Inoculate 0.1 ml of test vaccine onto each of 5 of the monolayers (test monolayers). Allow adsorption for 1 hour at 37° and add culture medium. Inoculate 4 of the monolayers with a suitable strain of duck enteritis virus (not more than 10 CCID<sub>50</sub> in 0.1 ml) to serve as positive controls. Maintain 2 non-inoculated monolayers as negative controls.

Incubate the cultures at 37° for a total of at least 21 days, subculturing at 4 to 5 day intervals. Each passage is made as follows:

Trypsinise the cells and prepare separate pools of the cells from the test monolayers, from the positive control monolayers and from the negative control monolayers. Mix a portion of each with a suspension of freshly prepared primary or secondary Muscovy duck embryo liver cells to prepare 5, 4 and 2 monolayers, as before. The test is not valid if less than 4 of the 5 test monolayers or less than 3 of the 4 positive controls or neither of the 2 negative controls survive after any passage.

For the last subculture, grow the cells on a suitable substrate so as to obtain an area of about 10 cm<sup>2</sup> of confluent cells from each of the original 11 monolayers for the subsequent test. Test about 10 cm<sup>2</sup> of confluent cells derived from each of the original 11 monolayers by immunostaining for the presence of duck enteritis virus. The test is not valid if duck enteritis virus is detected in less than 3 of the 4 positive control monolayers or in any of the negative control monolayers, or if the results for both of the 2 negative control monolayers are inconclusive. If the results for more than 1 of the test monolayers are inconclusive then further subcultures of reserved portions of the monolayers shall be made and tested until an unequivocal result is obtained.

The batch of vaccine complies with the test if there is no evidence of the presence of duck enteritis virus or any other extraneous agent.

#### **8. Test for duck and goose parvoviruses**

This test is carried out for vaccines prepared on duck or goose substrates.

Prepare a suspension of sufficient primary or secondary Muscovy duck embryo fibroblasts from the tissues of 16 to 18 day-old embryos, to obtain not less than 11 monolayers, each having an area of about 25 cm<sup>2</sup>. Inoculate 0.5 ml of test vaccine into an aliquot of cells for 5 monolayers and seed into 5 replicate containers to form 5 test monolayers.

Inoculate 0.4 ml of a suitable strain of duck parvovirus (not more than 10 CCID<sub>50</sub> in 0.1 ml) into an aliquot of cells for 4

monolayers and seed into 4 replicate containers to form 4 positive control monolayers. Prepare 2 non-inoculated monolayers as negative controls.

Incubate the cultures at 37° for a total of at least 21 days, subculturing at 4 to 5 day intervals. Each passage is made as follows:

Carry out a freeze-thaw cycle. Prepare separate pools of the cells plus fluid from the test monolayers, from the positive control monolayers and from the negative control monolayers. Inoculate 0.5 ml, 0.4 ml and 0.2 ml of the pooled materials into aliquots of a fresh suspension of sufficient primary or secondary Muscovy duck embryo fibroblast cells to prepare 5, 4 and 2 monolayers, as before.

The test is not valid if less than 4 of the 5 test monolayers or less than 3 of the 4 positive controls or neither of the 2 negative controls survive after any passage.

For the last subculture, grow the cells on a suitable substrate so as to obtain an area of about 10 cm<sup>2</sup> of confluent cells from each of the original 11 monolayers for the subsequent test: test about 10 cm<sup>2</sup> of confluent cells derived from each of the original 11 monolayers by immunostaining for the presence of duck or goose parvovirus. The test is not valid if duck parvovirus is detected in less than 3 of the 4 positive control monolayers or in any of the negative control monolayers, or if the results for both of the 2 negative control monolayers are inconclusive.

The batch of vaccine complies with the test if there is no evidence of the presence of duck (or goose) parvovirus or any other extraneous agent.

### 2.7.12. Evaluation of Efficacy of Vaccines and Immunosera

During development of a vaccine or immunosera, tests are carried out to demonstrate that the product is efficacious when administered by each of the recommended routes and methods of administration and using the recommended schedule to animals of each species and category for which use of the product is to be recommended. The type of efficacy testing to be carried out varies depending on the particular type of product.

During development of the product, the tests described in the Production section of a monograph may be carried out; the following must be taken into account:

The dose to be used is that quantity of the product to be recommended for use and containing the minimum titre or potency expected at the end of the period of validity.

For live vaccines, use vaccine containing virus/bacteria at the most attenuated passage level that will be present in a batch of vaccine.

For immunosera, if appropriate, the dose tested also contains minimum quantities of immunoglobulin or gammaglobulin and/or total protein.

The efficacy evidence must support all the claims being made. Where it is claimed that there is protection from infection this must be demonstrated using re-isolation techniques. If more than one claim is made, supporting evidence for each claim is required.

**Vaccines.** The influence of passively acquired and maternally derived antibodies on the efficacy of a vaccine is adequately evaluated. Any claims, stated or implied, regarding onset and duration of protection shall be supported by data from trials.

The efficacy of each of the components of multivalent and combined vaccines shall be demonstrated using the combined vaccine.

**Immunosera.** Particular attention must be paid to providing supporting data for the efficacy of the regime that is to be recommended. Any claim, stated or implied, regarding onset and duration of protection or therapeutic effect must be supported by data from trials. For example, the duration of the protection afforded by a prophylactic dose of an antiserum must be studied so that appropriate guidance for the user can be given on the label.

Studies of immunological compatibility are undertaken when simultaneous administration is recommended or where it is a part of a usual administration schedule. Wherever a product is recommended as part of an administration scheme, the priming or booster effect or the contribution of the product to the efficacy of the scheme as a whole is demonstrated.

#### Tests

In principle, demonstration of efficacy is undertaken under well-controlled laboratory conditions by challenge of the target animal under the recommended conditions of use.

To the extent possible, the conditions under which the challenge is carried out shall be close to the natural conditions for infection, for example with regard to the amount of challenge organism and the route of administration of the challenge.

**Vaccines.** Unless otherwise justified, challenge is carried out using a strain different from the one used in the production of the vaccine.

If possible, the immune mechanism (cell-mediated/humoral, local/general, classes of immunoglobulin) that is initiated after the administration of the vaccine to target animals shall be determined.

**Immunosera.** Data are provided from measurements of the antibody levels achieved in the target species after administration of the product, as recommended. Where suitable published data exist, references are provided to relevant

published literature on protective antibody levels and challenge studies are avoided.

Where challenges are required, these can be given before or after administration of the product, in accordance with the indications and specific claims to be made.

**Field trials.** In general, results from laboratory tests are supplemented with data from field trials, carried out, unless otherwise justified, with untreated control animals. Provided

that laboratory tests have adequately assessed the safety and efficacy of a product under experimental conditions using vaccines of maximum and minimum titre or potency respectively, a single batch of product could be used to assess both safety and efficacy under field conditions. In these cases, a typical routine batch of intermediate titre or potency may be used. Where laboratory trials cannot be supportive of efficacy, the performance of field trials alone may be acceptable.



## 2.8. TESTS ON BLOOD AND BLOOD-RELATED PRODUCTS

2.8.1. Nucleic Acid Amplification Technique	....
2.8.2. Human Anti-D Immunoglobulin Method A	....
2.8.3. Human Anti-D Immunoglobulin Methods B and C	....
2.8.4. Activated Coagulation Factors	....
2.8..5. Assay of Human Coagulation Factor II	....
2.8.6. Assay of Human Coagulation Factor VII	....
2.8.7. Assay of Human Coagulation Factor VIII	....
2.8.8. Assay of Human Coagulation Factor IX	....
2.8.9. Assay of Human Coagulation Factor X	....
2.8.10. Assay of Heparin in Coagulation Factors	....
2.8.11. Determination of ABO Blood Group and Rh Group	....
2.8.12. Determination of Haemoglobin by Photometry	....

### 2.8.1. Nucleic Acid Amplification Techniques

Nucleic acid amplification techniques are based on 2 different approaches:

1. Amplification of a target nucleic acid sequence using polymerase chain reaction (PCR), ligase chain reaction (LCR), or isothermal ribonucleic acid (RNA) amplification;
2. Amplification of a hybridisation signal using, for example, for deoxyribonucleic acid (DNA), the branched DNA (bDNA) method. In this case signal amplification is achieved without subjecting the nucleic acid to repetitive cycles of amplification.

In this general chapter, the PCR method is described as the reference technique. Alternative methods may be used, if they comply with the quality requirements described below.

**Scope.** This section establishes the requirements for sample preparation, *in vitro* amplification of DNA sequences and detection of the specific PCR product. With the aid of PCR, defined DNA sequences can be detected. RNA sequences can also be detected following reverse transcription of the RNA to complementary DNA (cDNA) and subsequent amplification.

**Principle of the method.** PCR is a procedure that allows specific *in vitro* amplification of segments of DNA or of RNA after reverse transcription into cDNA.

Following denaturation of double-stranded DNA into single-stranded DNA, 2 synthetic oligonucleotide primers of opposite polarity, anneal to their respective complementary sequences in the DNA to be amplified. The short double-stranded regions which form as a result of specific base pairing between the primers and the complementary DNA sequence, border the DNA segment to be amplified and serve as starting positions for *in vitro* DNA synthesis by means of a heat-stable DNA polymerase.

Amplification of the DNA occurs in cycles consisting of (a) heat denaturation of the nucleic acid (target sequence) into 2 single strands; (b) specific annealing of the primers to the target sequence under suitable reaction conditions; (c) extension of the primers, which are bound to both single strands, by DNA polymerase at a suitable temperature (DNA synthesis).

Repeated cycles of heat denaturation, primer annealing and DNA synthesis results in an exponential amplification of the DNA segment limited by the primers.

The specific PCR product known as an amplicon can be detected by a variety of methods of appropriate specificity and sensitivity.

Multiplex PCR assays use several primer pairs designed for simultaneous amplification of different targets in one reaction.

**Test material.** Because of the high sensitivity of PCR, the samples must be protected against external contamination with target sequences. Sampling, storage and transport of the test material are performed under conditions that minimize degradation of the target sequence. In the case of RNA target sequences, special precautions are necessary since RNA is highly sensitive to degradation by ribonucleases. Care must be taken since some added reagents, such as anticoagulants or preservatives, may interfere with the test procedure.

#### Test method

**Prevention of contamination.** The risk of contamination requires a strict segregation of the areas depending on the material handled and the technology used. Points to consider include movement of personnel, gowning, material flow and air supply and decontamination procedures.

The system should be sub-divided into compartments such as:

1. Master-mix area (area where exclusively template-free material is handled, e.g. primers, buffers, etc.);
2. Pre-PCR (area where reagents, samples and controls are handled);
3. PCR amplification (amplified material is handled in a closed system);
4. Post-PCR detection (the only area where the amplified material is handled in an open system).

**Sample preparation.** When preparing samples, the target sequence to be amplified needs to be efficiently extracted or liberated from the test material in a reproducible manner and in such a way that amplification under the selected reaction conditions is possible. A variety of physico-chemical extraction procedures and/or enrichment procedures may be employed.

Additives present in test material may interfere with PCR. The procedures described under Internal control must be used as a control for the presence of inhibitors originating from the test material.

In the case of RNA-templates, care must be taken to avoid ribonuclease activity.

**Amplification.** PCR amplification of the target sequence is conducted under defined cycling conditions (temperature profile for denaturation of double-stranded DNA, annealing and extension of primers; incubation times at selected temperatures; ramp rates). These depend on various parameters such as: (a) the length and base composition of primer and target sequences; (b) the type of DNA polymerase, buffer composition and reaction volume used for the amplification; (c) the type of thermocycler used and the thermal conductivity rate between the apparatus, reaction tube and reaction fluid.

**Detection.** The amplicon generated by PCR may be identified by size, sequence, chemical modification or a combination of these parameters. Detection and characterisation by size may be achieved by gel electrophoresis (using agarose or polyacrylamide slab gels or capillary electrophoresis) or column chromatography (for example, liquid chromatography). Detection and characterisation by sequence composition may be achieved by the specific hybridisation of probes having a sequence complementary to the target sequence or by cleavage of the amplified material reflecting target-specific restriction-enzyme sites. Detection and characterisation by chemical modification may be achieved by incorporation of a fluorophore into the amplicons and subsequent detection of fluorescence following excitation.

Detection of amplicons may also be achieved by using probes labelled to permit a subsequent radioisotopic or immuno-enzyme-coupled detection.

**Evaluation and interpretation of results.** A valid result is obtained within a test only if the positive control(s) is unambiguously positive and the negative control(s) is unambiguously negative. Due to the very high sensitivity of the PCR method and the inherent risk of contamination, it is necessary to confirm positive results by repeating the complete test procedure in duplicate, where possible on a new aliquot of the sample. The sample is considered positive if at least one of the repeat tests gives a positive result. As soon as a measurable target threshold is defined, a quantitative test system is required.

#### Quality assurance

**Validation of the PCR assay system.** The validation programme must include validation of instrumentation and the PCR method employed. Reference should be made to the *ICH guidelines* (topic Q2B) *Validation of Analytical Method: Methodology*.

Appropriate official working reference preparations or in-house reference preparations calibrated against International Standards for the target sequences for which the test system will be used are indispensable for validation of a PCR test.

**Determination of the positive cut-off point.** During validation of qualitative tests, the positive cut-off point must be determined. The positive cut-off point is defined as the minimum number of target sequences per volume sample which can be detected in 95.0 per cent of test runs. The positive cut-off point depends on interrelated factors such as the volume of the sample extracted and the efficacy of the extraction methodology, the transcription of the target RNA into cDNA, the amplification process and the detection.

To define the detection limit of the assay system, reference must be made to the positive cut-off point for each target

sequence and the test performance above and below the positive cut-off point.

**Quantitative assay systems.** For a quantitative assay, the following parameters are determined during validation: accuracy, precision, specificity, quantitation limit, linearity, range and robustness.

**Quality control of reagents.** All reagents crucial for the methodology used have to be controlled prior to use in routine applications. Their acceptance/withdrawal is based on pre-defined quality criteria.

Primers are a crucial component of the PCR assay and as such their design, purity and the validation of their use in a PCR assay require careful attention. Primers may be modified (for example, by conjugation with a fluorophore or antigen) in order to permit a specific method of detection of the amplicon, provided such modifications do not inhibit accurate and efficient amplification of the target sequence.

#### Run controls

**External controls.** In order to minimise the risk of contamination and to ensure adequate sensitivity, the following external controls are included in each PCR assay:

**Positive control.** This contains a defined number of target-sequence copies, the number being close to the positive cut-off value, and determined individually for each assay system and indicated as a multiple of the positive cut-off value of the assay system;

**Negative control.** A sample of a suitable matrix already proven to be free of the target sequences.

**Internal control.** Internal controls are defined nucleic acid sequences containing, unless otherwise prescribed, the primer binding sites. Internal controls must be amplified with defined efficacy, and the amplicons must be clearly discernible. Internal controls must be of the same type of nucleic acid (DNA/RNA) as the material under test. The internal control is preferably added to the test material before isolating the nucleic acid and therefore acts as an overall control (extraction, reverse transcription, amplification, detection).

**Threshold control.** The threshold control for quantitative assays is a test sample with the analyte at a concentration which is defined as the threshold not to be exceeded. It contains the analyte suitably calibrated in IU and is analysed in parallel in each run of a quantitative assay.

**External quality assessment.** Participation in external quality assessment programmes is an important PCR quality assurance procedure for each laboratory and each operator.

*The following section is published for information.*

**Validation of Nucleic Acid Amplification Techniques (NAT) for the Detection of Hepatitis C Virus (HCV) RNA in Plasma Pools: Guidelines**

**Scope.** The majority of nucleic acid amplification analytical procedures are qualitative (quantal) tests for the presence of nucleic acid with some quantitative tests (either in-house or commercial) being available. For the detection of HCV RNA contamination of plasma pools, qualitative tests are adequate and may be considered to be a limit test for the control of impurities as described in the *Pharmeuropa* Technical Guide for the elaboration of monographs, December 1999, Chapter III "Validation of analytical procedures". These guidelines describe methods to validate only qualitative nucleic acid amplification analytical procedures for assessing HCV RNA contamination of plasma pools. Therefore, the 2 characteristics regarded as the most important for validation of the analytical procedure are the specificity and the detection limit. In addition, the robustness of the analytical procedure should be evaluated.

However, this document may also be used as a basis for the validation of nucleic acid amplification in general.

For the purpose of this document, an analytical procedure is defined as the complete procedure from extraction of nucleic acid to detection of the amplified products.

Where commercial kits are used for part of or the complete analytical procedure, documented validation points already covered by the kit manufacturer can substitute for the validation by the user. Nevertheless, the performance of the kit with respect to its intended use has to be demonstrated by the user (e.g. detection limit, robustness, cross contamination).

**Specificity.** Specificity is the ability to unequivocally assess nucleic acid in the presence of components which may be expected to be present.

The specificity of nucleic acid amplification analytical procedures is dependent on the choice of primers, the choice of probe (for analysis of the final product) and the stringency of the test conditions (for both the amplification and detection steps).

When designing primers and probes, the specificity of the primers and probes to detect only HCV RNA should be investigated by comparing the chosen sequences with sequences in published data banks. For HCV, primers (and probes) will normally be chosen from areas of the 5' non-coding region of the HCV genome which are highly conserved for all genotypes.

The amplified product should be unequivocally identified by using one of a number of methods such as amplification with nested primers, restriction enzyme analysis, sequencing or hybridisation with a specific probe.

In order to validate the specificity of the analytical procedure, at least 100 HCV RNA-negative plasma pools should be tested and shown to be non-reactive.

The ability of the analytical procedure to detect all HCV genotypes will again depend on the choice of primers, probes and method parameters. This ability should be demonstrated using characterised reference panels. However, in view of the difficulty in obtaining samples of some genotypes (e.g. genotype 6), the most prevalent genotypes should be detected at a suitable level.

**Detection limit.** The detection limit of an individual analytical procedure is the lowest amount of nucleic acid in a sample which can be detected but not necessarily quantitated as an exact value.

The nucleic acid amplification analytical procedure used for the detection of HCV RNA in plasma pools usually yields qualitative results. The number of possible results is limited to two, either positive or negative. Although the determination of the detection limit is recommended, for practical purposes, a positive cut-off point should be determined for the nucleic acid amplification analytical procedure. The positive cut-off point (as defined in the General Chapter (2.8.1)) is the minimum number of target sequences per volume sample which can be detected in 95.0 per cent of test runs. This positive cut-off point is influenced by the distribution of viral genomes in the individual samples being tested and by factors such as enzyme efficiency and can result in different 95.0 per cent cut-off values for individual analytical test runs.

In order to determine the positive cut-off point, a dilution series of a working reagent or of the *hepatitis C virus reference preparation*, which has been calibrated against the WHO HCV International Standard 96/790, should be tested on different days to examine variation between test runs. At least 3 independent dilution series should be tested with a sufficient number of replicates at each dilution to give a total number of 24 test results for each dilution to enable a statistical analysis of the results.

For example, a laboratory could test 3 dilution series on different days with 8 replicates for each dilution, 4 dilution series on different days with 6 replicates for each dilution, or 6 dilution series on different days with 4 replicates for each dilution. In order to keep the number of dilutions at a manageable level, a preliminary test (using log dilutions of the plasma pool sample) should be done in order to obtain a preliminary value for the positive cut-off point (i.e. the highest dilution giving a positive signal). The range of dilutions can then be chosen around the predetermined preliminary cut-off point (using a dilution factor of 0.5 log or less and a negative plasma pool for the dilution matrix). The concentration of HCV RNA which can be detected in 95.0 per cent of test runs can then be calculated using an appropriate statistical evaluation.



These results may also serve to demonstrate the intra-assay variation and the day-to-day variation of the analytical procedure.

**Robustness.** The robustness of an analytical procedure is a measure of its capacity to remain unaffected by small but deliberate variations in method parameters and provides an indication of its reliability during normal usage.

The evaluation of robustness should be considered during the development phase. It should show the reliability of the analytical procedure with respect to deliberate variations in method parameters. For NAT, small variations in the method parameters can be crucial. However, the robustness of the method can be demonstrated during its development when small variations in the concentrations of reagents (e.g. MgCl<sub>2</sub>, primers or dNTP) are tested. To demonstrate robustness, at least 20 HCV RNA negative plasma pools (selected at random) spiked with HCV RNA to a final concentration of 3 times the previously determined 95.0 per cent cut-off value should be tested and found positive.

Problems with robustness may also arise with methods which use an initial ultracentrifugation step prior to extraction of the viral RNA. Therefore, to test the robustness of such methods, at least 20 plasma pools containing varying levels of HCV RNA, but lacking HCV specific antibodies, should be tested and found positive.

Cross contamination prevention should be demonstrated by the accurate detection of a panel of at least 20 samples consisting of alternate samples of negative plasma pools and negative plasma pools spiked with high concentrations of HCV (at least 10<sup>2</sup> times the 95.0 per cent cut-off value or at least 10<sup>4</sup> IU/ml).

**Quality assurance.** For biological tests such as NAT, specific problems may arise which may influence both the validation and interpretation of results. The test procedures must be described precisely in the form of standard operating procedures (SOPs). These should cover: (a) the mode of sampling (type of container, etc.); (b) the preparation of mini-pools (where appropriate); (c) the conditions of storage before analysis; (d) the exact description of the test conditions, including precautions taken to prevent cross contamination or destruction of the viral RNA, reagents and reference preparations used; (e) the exact description of the apparatus used; (f) the detailed formulae for calculation of results, including statistical evaluation.

The use of a suitable run control (for example, an appropriate dilution of *hepatitis C virus reference preparation* or plasma spiked with an HCV sample calibrated against the WHO HCV International Standard 96/790) can be considered a satisfactory system suitability check and ensures that the reliability of the analytical procedure is maintained whenever used.

**Technical qualification.** An appropriate installation and operation qualification programme should be implemented for each critical piece of the equipment used. Confirmation of analytical procedure performance after change of critical equipment (e.g. thermocyclers) should be documented by conducting a parallel test on 8 replicate samples of a plasma pool spiked with HCV RNA to a final concentration of 3 times the previously determined 95.0 per cent cut-off value. All results should be positive.

**Operator qualification.** An appropriate qualification programme should be implemented for each operator involved in the testing. To confirm successful training each operator should test at least 8 replicate samples of a plasma pool spiked with HCV RNA to a final concentration of 3 times the previously determined 95.0 per cent cut-off value. This test (8 replicate samples) should be repeated twice on two separate days, i.e. a total of 24 tests performed on three different days. All results should be positive.

## 2.8.2. Assay of Human Anti-D Immunoglobulin Method A

**Method A.** The potency of human anti-D immunoglobulin is determined by comparing the quantity necessary to produce agglutination of D-positive red blood cells with the quantity of a reference preparation, calibrated in International Units, required to produce the same effect.

The International Unit is the activity contained in a stated amount of the International Reference Preparation. The equivalence in International Units of the International Reference Preparation is stated by the World Health Organisation.

Human anti-D immunoglobulin reference preparation is calibrated in International Units by comparison with the International Standard and intended for use in the assay of human anti-D immunoglobulin.

Use pooled D-positive red blood cells, collected not more than 7 days earlier and suitably stored, obtained from not fewer than 4 group O R<sub>1</sub>R<sub>1</sub> donors. To a suitable volume of the cells, previously washed 3 times with a 0.9 per cent w/v solution of *sodium chloride*, add an equal volume of *bromelains solution*, allow to stand at 37° for 10 minutes, centrifuge, remove the supernatant liquid and wash 3 times with a 0.9 per cent w/v solution of *sodium chloride*. Suspend 20 volumes of the red blood cells in a mixture of 15 volumes of inert serum, 20 volumes of a 30.0 per cent w/v solution of *bovine albumin* and 45 volumes of a 0.9 per cent w/v solution of *sodium chloride*. Stand the resulting suspension in iced water, stirring continuously.

Using a calibrated automated dilutor, prepare suitable dilutions of the preparation under examination and of the reference

preparation using as diluent a solution containing 0.5 per cent w/v of *bovine albumin* and 0.9 per cent w/v of *sodium chloride*.

Use a suitable apparatus for automatic continuous analysis. The following protocol is usually suitable: maintain the temperature in the manifold, except for the incubation coils, at 15°. Pump into the manifold of the apparatus the red blood cell suspension at a rate of 0.1 ml per min and a 0.3 per cent w/v solution of *methylcellulose 450* at a rate of 0.05 ml per min. Introduce the dilutions of the preparation under examination and the reference preparation at a rate of 0.1 ml per min for 2 minutes, followed by the *diluent solution* at a rate of 0.1 ml per min for 4 minutes before the next dilution is introduced. Introduce air at a rate of 0.6 ml per min. Incubate at 37° for 18 minutes and then disperse the rouleaux by introducing at a rate of 1.6 ml per min a 0.9 per cent w/v solution of *sodium chloride* containing a suitable wetting agent (for example, *polysorbate 20* at a final concentration of 0.02 per cent w/v to prevent disruption of the bubble pattern. Allow the agglutinates to settle and decant twice, first at 0.4 ml per min and then at 0.6 ml per min. Lyse the unagglutinated red blood cells with a solution containing 0.5 per cent w/v of *octoxinol 10*, 0.02 per cent w/v of *potassium ferricyanide*, 0.1 per cent w/v of *sodium hydrogen carbonate* and 0.005 per cent w/v of *potassium cyanide* at a rate of 2.5 ml per min. A ten-minute delay coil is introduced to allow for conversion of the haemoglobin. Continuously record the absorbance (2.4.7) of the haemolysate at a wavelength between 540 to 550 nm. Determine the range of antibody concentrations over which there is a linear relationship between concentration and the resultant change in absorbance (ÅA). From the results, prepare a standard curve and use the linear portion of the curve to determine the activity of the preparation under examination.

Calculate the potency of the preparation under examination using the usual statistical methods.

### 2.8.3. Assay of Human Anti-D Immunoglobulin Method B and C

**Method B.** The potency of human anti-D immunoglobulin is determined by competitive enzyme-linked immunoassay on erythrocyte-coated microtitre plates. The method is based on the competitive binding between a polyclonal anti-D immunoglobulin preparation and a biotinylated monoclonal anti-D antibody directed against a D-antigen specific epitope. The activity of the preparation under examination is compared with a reference preparation calibrated in International Units.

The International Unit is the activity of a stated amount of International Reference Preparation. The equivalence in International Units of the International reference preparation is stated by the World Health Organisation.

Human anti-D immunoglobulin reference preparation is calibrated in International Units by comparison with the International Standard and intended for use in the assay of human anti-D immunoglobulin.

**Materials.** Reagents not specified are of analytical grade.

**PBS (Phosphate-buffered saline).** Dissolve 8.0 g of *sodium chloride*, 0.76 g of *anhydrous disodium hydrogen phosphate*, 0.2 g of *potassium chloride*, 0.2 g of *potassium dihydrogen phosphate* and 0.2 g of *sodium azide* in *water* and dilute to 1,000 ml with the same solvent.

**TBS (Tris-buffered saline).** Dissolve 8.0 g of *sodium chloride* and 0.6 g of *tris (hydroxymethyl) aminomethane* in *water*. Adjust to pH 7.2 with *1 M hydrochloric acid* and dilute to 1,000 ml with the same solvent.

**Papain solution.** Prepare a solution by stirring 1 g of *papain* at 37° for 30 minutes in 10 ml of *0.067 M phosphate buffer solution pH 5.4*, centrifuge at 10,000 g for 5 minutes and filter through a membrane with a pore size of 0.22 µm. To activate, combine 1 ml of the filtrate with 1 ml of a 4.844 per cent w/v solution of *L-cysteine* and 1 ml of a 0.372 per cent w/v solution of *sodium edetate* and dilute to 10 ml with *0.067 M phosphate buffer solution pH 5.4*. Freeze in aliquots at -20° or below.

**Red blood cells.** Use pooled D-positive red blood cells obtained from not fewer than 3 group OR<sub>2</sub>R<sub>2</sub> donors. Wash the cells 4 times with *PBS*. Centrifuge the cells at 1,800 g for 5 minutes, mix a suitable volume of prewarmed packed cells with a suitable volume of prewarmed papain solution (2 volumes to 1 volume suitable) and incubate at 37° for 10 minutes. Wash the cells 4 times with *PBS*. Store at 4° in an appropriate stabiliser for up to 1 week.

**Biotinylated Brad-5.** Use according to instructions.

**Alkaline phosphatase-conjugated avidin/streptavidin reagent.** Preferably modified to combine high specific activity with low non-specific binding. Use according to instructions.

**Substrate solution.** Use *para*-nitrophenyl phosphate according to instructions.

**Cell fixation buffer.** Dissolve 18.02 g of *glucose*, 4.09 g of *sodium chloride*, 1.24 g of *boric acid*, 10.29 g of *sodium citrate* and 0.74 g of *sodium edetate* in *water*. Adjust to pH 7.2 to 7.3 using *1 M sodium hydroxide* or *1 M hydrochloric acid*, and dilute to 1,000 ml with *water* and store at 4°.

**Glutaraldehyde solution.** Immediately before use, add 90 µl of a 25.0 per cent w/v solution of *glutaraldehyde* to 24 ml of cold *PBS*.

**Microtitre plates.** Plates to be coated with red blood cells are flat-bottomed polystyrene plates with surface properties optimised for enzyme immunoassay and high protein-binding capacity. Plates used to prepare immunoglobulin dilutions are U or V-bottomed polystyrene or poly(vinyl chloride) plates.

**Method.** Prepare a 0.1 per cent v/v suspension of papain-treated red blood cells in *cold cell fixation buffer*. Pipette 50 µl into each well of the flat-bottomed microtitre plate.

Centrifuge the plate at 350 g for 3 minutes, preferably at 4°. Without removing the supernatant, gently add 100 µl of *glutaraldehyde solution* to each well and leave for 10 minutes.

Drain the wells by quickly inverting the plate and wash 3 times with 250 to 300 µl of *PBS*. This may be done manually or using a suitable automated plate washer. Either carry out the assay as described below, or store the plate at 4° after draining off the *PBS* and adding 100 µl of cell fixation buffer per well and sealing with plastic film. Plates can be stored at 4° for up to 1 month.

**Test solutions.** For freeze-dried preparations, reconstitute as stated on the label. Prepare 4 independent replicates of 5 serial two-fold dilutions starting with 30 IU per ml in *PBS* containing 1.0 per cent w/v of *bovine albumin*. If necessary, adjust the starting dilution to obtain responses falling in the linear portion of the dose-response curve.

**Reference solutions.** Reconstitute the reference preparation according to instructions. Prepare 4 independent replicates of 5 serial two-fold dilutions starting with 30 IU per ml in *PBS* containing 1.0 per cent w/v of *bovine albumin*.

Using U or V-bottomed microtitre plates, add 35 µl of each of the dilutions of the test solution or reference solution to each of a series of wells. To each well add 35 µl of *biotinylated Brad-5* at 250 ng per ml.

Empty the wells of the red cell-coated plate by inverting and draining on a paper towel. Add 250 µl of *PBS* containing 2.0 per cent w/v of *bovine albumin* and leave at room temperature for 30 minutes.

Empty the wells of the red cell-coated plate by inverting and draining on a paper towel and transfer 50 µl from each of the dilutions of the test solution or reference solution containing *biotinylated Brad-5* into the wells. Use 50 µl of *PBS* containing 1.0 per cent w/v of *bovine albumin* as negative control. Seal the plate with plastic film and incubate at room temperature for 1 hour.

Remove liquid from the wells of the red cell-coated plate and wash 3 times with 250 to 300 µl of *TBS*.

Dilute the *alkaline phosphatase-conjugated avidin/streptavidin reagent* in *TBS* containing 1.0 per cent w/v of *bovine albumin* and add 50 µl to each well. Incubate for 30 minutes at room temperature.

Remove liquid from the wells of the red cell-coated plate and wash 3 times with 250 to 300 µl of *TBS*.

Add 100 µl of *substrate solution* to each of the wells and incubate at room temperature for 10 minutes in the dark. To

stop the reaction, add 50 µl of 3 M *sodium hydroxide* to each of the wells.

Measure the absorbances at 405 nm and subtract the negative control reading. Use the absorbance values in the linear range of the titration curve to estimate the potency of the preparation under examination by the usual statistical methods.

**Method C.** The potency of human anti-D immunoglobulin is determined by flow cytometry in a microtitre plate format. The method is based on the specific binding between anti-D immunoglobulin and D-positive red blood cells. The activity of the preparation under examination is compared with a reference preparation calibrated in International Units.

The International Unit is the activity of a stated amount of International Reference Preparation. The equivalence in International Units of the International Reference Preparation is stated by the World Health Organisation.

*Human anti-D immunoglobulin reference preparation* is calibrated in International Units by comparison with the International Standard and intended for use in the assay of human anti-D immunoglobulin.

**Materials.** Reagents used are of analytical grade.

**PBS.** Dissolve 8.0 g of *sodium chloride*, 0.76 g of *disodium hydrogen phosphate*, 0.2 g of *potassium chloride* and 0.2 g of *potassium dihydrogen phosphate* in *water* and dilute to 1,000 ml with the same solvent.

**PBS-BSA solution.** *PBS* containing 1.0 per cent w/v of *bovine albumin*.

**Red blood cells.** Use D-positive red blood cells obtained from a group O R<sub>1</sub>R<sub>1</sub> donor within 2 weeks of collection. Store if necessary in an appropriate stabiliser at 4°. Wash the cells at least twice with *PBS-BSA solution* and prepare a suspension containing 1 × 10<sup>4</sup> cells per microlitre but not more than 5 × 10<sup>4</sup> cells per microlitre in *PBS-BSA solution*.

Use D-negative red blood cells obtained from a group O rr donor and prepared similarly.

**Secondary antibody.** Use a suitable fluorescent dye conjugated anti-IgG antibody-fragment specific for human IgG or parts of it. Store and use according to the manufacturer's instructions.

**Microtitre plates.** Use flat-bottomed plates without surface treatment for enzyme immunoassays.

#### Method

**Test solutions.** For freeze-dried preparations, reconstitute as stated on the label. Prepare at least 3 independent replicates of at least 3 serial 1.5 or two-fold dilutions starting with a concentration in the range of 1.2-0.15 IU per ml using *PBS/BSA solution* as diluent. If necessary, adjust the starting dilution to obtain responses falling in the linear portion of the dose-response curve.



*Reference solutions.* Reconstitute the reference preparation according to instructions. Prepare at least 3 independent replicates of at least 3 serial 1.5 or two-fold dilutions starting with a concentration in the range of 1.2-0.15 IU per ml using *PBS-BSA solution* as diluent. If necessary, adjust the starting dilution to obtain responses falling in the linear portion of the dose-response curve.

Distribute 50 µl of the D-positive red blood cells into each well of a microtitre plate. Add 50 µl of each of the dilutions of the test solution or reference solution to each of a series of wells. Use 50 µl of *PBS-BSA solution* as negative control. Distribute 50 µl of the D-negative red blood cells into 4 wells of the same microtitre plate and add 50 µl of the lowest dilution of the test preparation. To monitor spurious reactions distribute 50 µl of the D-positive red blood cells into 4 wells of the same microtitre plate and add 50 µl of *PBS-BSA solution*. Seal with plastic film and incubate at 37° for 40 minutes.

Centrifuge the plates at 50 g for 3 minutes, discard the supernatant and wash the cells with 200 to 250 µl of *PBS-BSA solution*. Repeat this at least once.

Centrifuge the plates at 50 g for 3 minutes, discard the supernatant and add 50 µl of the *secondary antibody diluted with PBS-BSA solution* to a suitable protein concentration. Seal with plastic film and incubate, protected from light, at room temperature for 20 minutes.

Centrifuge the plates at 50 g for 3 minutes, discard the supernatant and wash the cells with 200 to 250 µl of *PBS-BSA solution*. Repeat this at least once.

Centrifuge the plates at 50 g for 3 minutes, resuspend the cells into 200 to 250 µl of *PBS*. Transfer the cell suspension into a tube suitable for the flow cytometry equipment available and further dilute by adding *PBS* to allow a suitable flow rate.

Proceed immediately with measurement of the median fluorescence intensity in a flow cytometer. Record at least 10,000 events without gating but excluding debris.

Use the median fluorescence intensity in the linear range of the dose response curve to estimate the potency of the preparation under examination by the usual statistical methods.

## 2.8.4. Activated Coagulation Factors

Where applicable, determine the amount of heparin present (2.8.10) and neutralise the heparin, for example by addition of *protamine sulphate* (10 µg of protamine sulphate neutralises 1 IU of heparin). Prepare 1 to 10 and 1 to 100 dilutions of the preparation under examination using *tris(hydroxymethyl)aminomethane buffer solution pH 7.5*. Place a series of polystyrene tubes in a water-bath at 37° and add to each tube 0.1 ml of *platelet-poor plasma* and 0.1 ml of a suitable dilution

of a phospholipid preparation to act as a platelet substitute. Allow to stand for 60 seconds. Add to each tube either 0.1 ml of 1 of the dilutions or 0.1 ml of the *buffer solution* (control tube). To each tube add immediately 0.1 ml of a 0.37 per cent w/v solution of *calcium chloride* previously heated to 37°, and measure, within 30 minutes of preparing the original dilution, the time that elapses between addition of the calcium chloride solution and the formation of a clot. The test is not valid unless the coagulation time measured for the control tube is 200 to 350 seconds.

## 2.8.5. Assay of Human Coagulation Factor II

Human coagulation factor II is assayed following specific activation to form factor IIa. Factor IIa is estimated by comparing its activity in cleaving a specific chromogenic peptide substrate with the same activity of the International Standard or of a reference preparation calibrated in International Units.

The International Unit is the factor II activity of a stated amount of the International Standard which consists of a freeze-dried concentrate of human blood coagulation factor II. The equivalence in International Units of the International Standard is stated by the World Health Organisation.

The chromogenic assay method consists of 2 steps: snake venom-dependent activation of factor II, followed by enzymatic cleavage of a chromogenic factor IIa substrate to form a chromophore that can be quantified spectrophotometrically. Under appropriate assay conditions, there is a linear relation between factor IIa activity and the cleavage of the chromogenic substrate.

### Reagents

**Viper venom specific factor II activator (Ecarin).** A protein derived from the venom of the saw-scaled viper (*Echis carinatus*) which specifically activates factor II. Reconstitute according to the manufacturer's instructions. Store the reconstituted preparation at 4° and use within 1 month.

**Factor IIa chromogenic substrate.** Specific chromogenic substrate for factor IIa such as: *H-D-phenylalanyl-L-pipecolyl-L-arginine-4-nitroanilide dihydrochloride*, *4-toluenesulphonyl-glycyl-prolyl-L-arginine-4-nitroanilide*, *H-D-cyclohexylglycyl- $\alpha$ -aminobutyryl-L-arginine-4-nitroanilide*, *D-cyclohexylglycyl-L-alanyl-L-arginine-4-nitroanilide* diacetate. Reconstitute according to the manufacturer's instructions.

**Dilution buffer.** Solution containing 0.606 per cent w/v of *tris(hydroxymethyl)aminomethane*, 1.753 per cent w/v of *sodium chloride*, 0.279 per cent w/v of *(ethylenedinitrilo)tetra-acetic acid* and 0.1 per cent w/v of *bovine albumin* or *human albumin*. Adjust to pH 8.4 if necessary, using *hydrochloric acid*.



**Method**

*Test solution.* Dilute the preparation under examination with *dilution buffer* to obtain a solution containing 0.015 IU of factor II per ml. Prepare at least 3 further dilutions in *dilution buffer*.

*Reference solution.* Dilute the reference preparation with *dilution buffer* to obtain a solution containing 0.015 IU of factor II per ml. Prepare at least 3 further dilutions in *dilution buffer*.

Warm all solutions to 37° in a water-bath shortly before the test.

The following working conditions apply to microtitre plates. If the assay is carried out in tubes, the volumes are adjusted while maintaining the proportions in the mixture.

Using a microtitre plate maintained at 37°, add 25 µl of each dilution of the test solution or the reference solution to each of a series of wells. To each well add 125 µl of *dilution buffer*, then 25 µl of ecarin and incubate for exactly 2 minutes. To each well add 25 µl of *factor IIa chromogenic substrate*.

Read the rate of change of absorbance (2.4.7) at 405 nm continuously over a period of 3 minutes and obtain the mean rate of change of absorbance (ÅÅ per minute). If continuous monitoring is not possible, read the absorbance at 405 nm at suitable consecutive intervals, for instance 40 seconds, plot the absorbances against time on a linear graph and calculate ÅÅ per minute as the slope of the line. From the ÅÅ per minute values of each individual dilution of standard and test preparations, calculate the potency of the preparation under examination and check the validity of the assay by the usual statistical method.

**2.8.6. Assay of Human Coagulation Factor VII**

Human coagulation factor VII is assayed by its biological activity as a factor VIIa-tissue factor complex in the activation of factor X in the presence of calcium ions and phospholipids. The potency of a factor VII preparation is estimated by comparing the quantity necessary to achieve a certain rate of factor Xa formation in a test mixture containing the substances that take part in the activation of factor X, and the quantity of the International Standard, or of a reference preparation calibrated in International Units, required to produce the same rate of factor Xa formation.

The International Unit is the factor VII activity of a stated amount of the International Standard which consists of freeze-dried plasma. The equivalence in International Units of the International Standard is stated by the World Health Organisation.

The chromogenic assay method consists of 2 consecutive steps: the factor VII-dependent activation of factor X reagent

mixture containing tissue factor, phospholipids and calcium ion, followed by enzymatic cleavage of a chromogenic factor Xa substrate into a chromophore that can be quantified spectrophotometrically. Under appropriate assay conditions, there is a linear relation between the rate of factor Xa formation and the factor VII concentration. The assay is summarised by the following scheme Figure 2.

**Step 1****Step 2**

Figure 1. Schematic representation of the assay of human coagulation factor VII

Both steps employ reagents that may be obtained commercially from a variety of sources. Although the composition of individual reagents may be subject to some variation, their essential features are described in the following specification.

**Reagents.** The coagulation factor reagent comprises purified proteins derived from human or bovine sources. These include factor X and thromboplastin tissue factor/phospholipid as factor VII activator. These proteins are partly purified and do not contain impurities that interfere with the activation of factor VII or factor X. Factor X is present in amounts giving a final concentration during the first step of the assay of 10 nmol per litre to 350 nmol per litre, preferably 14 nmol per litre to 70 nmol per litre. Thromboplastin from natural sources (bovine or rabbit brain) or synthetic preparations may be used as the tissue factor/phospholipid component. Thromboplastin suitable for use in prothrombin time determination is diluted 1:5 to 1:50 in buffer such that the final concentration of Ca<sup>2+</sup> is 15 mmol per litre to 25 mmol per litre. The final factor Xa generation is performed in a solution containing human or bovine albumin at a concentration such that adsorption losses do not occur and which is appropriately buffered at pH 7.3 to 8.0. In the final incubation mixture, factor VII must be the only rate-limiting component and each reagent component must lack the ability to generate factor Xa on its own.

The second step comprises the quantification of the formed factor Xa employing a chromogenic substrate that is specific for factor Xa. Generally this consists of a short peptide of between three and five amino acids, bound to a chromophore group. On cleavage of this group from the peptide substrate, its absorption maximum shifts to a wavelength allowing its spectrophotometric quantification. The substrate is usually dissolved in *water* and used at a final concentration of 0.2 to 2 mmol per litre. The substrate may also contain appropriate

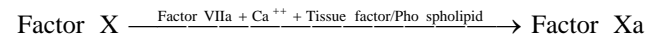
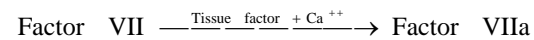
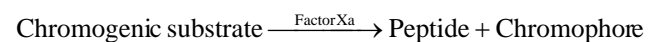
inhibitors to stop further factor Xa generation (addition of edetate).

### Assay

Reconstitute the entire contents of one ampoule of the reference preparation and the preparation under examination by adding the appropriate quantity of *water*; use within 1 hour. Add sufficient prediluent to the reconstituted preparations to produce solutions containing between 0.5 to 2.0 IU of factor VII per ml.

Prepare further dilutions of reference and test preparations using an *isotonic non-chelating buffer containing 1.0 per cent of bovine or human albumin*, buffered preferably between pH 7.3 and 8.0. Prepare at least three separate, independent dilutions for each material, preferably in duplicate. Prepare the dilutions such that the final factor VII concentration is below 0.005 IU per ml.

Prepare a control solution that includes all components except factor VII.

*Prepare all dilutions in plastic tubes and use within 1 hour.*

**Step 1.** Mix dilutions of the factor VII reference preparation and the preparation under examination with an appropriate volume of the *prewarmed coagulation factor reagent* or a combination of its separate constituents, and incubate the mixture in plastic tubes or microplate wells at 37°. The concentrations of the various components during the factor Xa generation must be as specified above under the description of the Reagents.

Allow the activation of factor X to proceed for a suitable time, usually terminating the reaction before the factor Xa concentration has reached its maximal level in order to obtain a satisfactory linear dose-response relationship. The activation time is also chosen to achieve linear production of factor Xa in time. Appropriate activation times are usually between 2 to 5 minutes, but deviations are permissible if acceptable linearity of the dose-response relationship is thus obtained.

**Step 2.** Terminate the activation by the addition of a *prewarmed reagent containing a chromogenic substrate*. Quantify the rate of substrate cleavage, which must be linear with the concentration of factor Xa formed, by measuring the absorbance change at an appropriate wavelength using a spectrophotometer, either monitoring the absorbance continuously, thus allowing the initial rate of substrate cleavage to be calculated, or terminating the hydrolysis reaction after a suitable interval by lowering the pH by the addition of a suitable reagent, such as *acetic acid* (50.0 per cent w/v C<sub>2</sub>H<sub>4</sub>O<sub>2</sub>) or a *citrate solution* (1 mol per litre) at pH 3. Adjust the hydrolysis time to achieve a linear development of chromophore with time. Appropriate hydrolysis times are usually between 3 to 15 minutes, but deviations are permissible

if better linearity of the dose-response relationship is thus obtained.

Check the validity of the assay and calculate the potency of the test preparation by the usual statistical methods.

### 2.8.7. Assay of Human Coagulation Factor VIII

Human coagulation factor VIII is assayed by its biological activity as a cofactor in the activation of factor X by activated factor IX (factor IXa) in the presence of calcium ions and phospholipid. The potency of a factor VIII preparation is estimated by comparing the quantity necessary to achieve a certain rate of factor Xa formation in a test mixture containing the substances that take part in the activation of factor X, and the quantity of the International Standard, or of a reference preparation calibrated in International Units, required to produce the same rate of factor Xa formation.

The International Unit is the factor VIII activity of a stated amount of the International Standard, which consists of a freeze-dried human coagulation factor VIII concentrate. The equivalence in International Units of the International Standard is stated by the World Health Organisation.

*Human coagulation factor VIII reference preparation* is calibrated in International Units by comparison with the International Standard.

The chromogenic assay method consists of 2 consecutive steps: the factor VIII-dependent activation of factor X in a coagulation-factor reagent composed of purified components, and the enzymatic cleavage of a chromogenic factor Xa substrate to yield a chromophore that can be quantified spectrophotometrically. Under appropriate assay conditions, there is a linear relation between the rate of factor Xa formation and the factor VIII concentration. The assay is summarised by the following scheme Figure 2.

#### Step 1

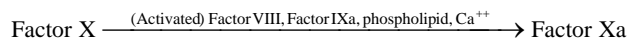

#### Step 2

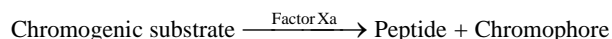

Figure 2.

Both steps employ reagents that may be obtained commercially from a variety of sources. Although the composition of individual reagents may be subject to some variation, their essential features are described in the following specification. Deviations from this description may be permissible provided that it has been shown, using the International Standard for human blood coagulation factor VIII concentrate as the standard, that the results obtained do not differ significantly.

It is important to demonstrate by validation the suitability of the kit used, notably by checking the time course of factor Xa generation in order to determine the time taken to reach 50.0 per cent of the maximal factor Xa generation.

**Reagents.** The coagulation factor reagent comprises purified proteins derived from human or bovine sources. These include factor X, factor IXa, and a factor VIII activator, usually thrombin. These proteins are partly purified, preferably to at least 50.0 per cent, and do not contain impurities that interfere with the activation of factor VIII or factor X. Thrombin may be present in its precursor form prothrombin, provided that its activation in the reagent is sufficiently rapid to give almost instantaneous activation of factor VIII in the assay. Phospholipid may be obtained from natural sources or be synthetically prepared, and must, to a substantial extent, consist of the species phosphatidylserine. The components of the complete reagent are usually divided into at least 2 separate reagents, each lacking the ability to generate factor Xa on its own. One of the reagents contains calcium ions. After reconstitution, the reagents may be combined provided that no substantial amounts of factor Xa are generated in the absence of factor VIII. In the final incubation mixture, factor VIII must be the only rate-limiting component.

The 2nd step comprises the quantification of the formed factor Xa, employing a chromogenic substrate that is specific for factor Xa. Generally this consists of a derivatised short peptide of between 3 to 5 amino acids, joined to a chromophore group. On cleavage of this group from the peptide substrate, its chromophoric properties shift to a wavelength allowing its spectrophotometric quantification. The substrate must also contain appropriate inhibitors to stop further factor Xa generation, e.g. chelating agents, and to suppress thrombin activity.

### Assay

Reconstitute the entire contents of 1 ampoule of the reference preparation and of the preparation under examination; use immediately. Add sufficient prediluent to the reconstituted preparations to produce solutions containing 0.5 to 2.0 IU per ml.

The prediluent consists of haemophilia A plasma, or of an artificially prepared reagent that contains sufficient von Willebrand factor and that gives results that do not differ significantly from those obtained employing haemophilia plasma. The prediluted materials must be stable beyond the time required for the assay.

Prepare further dilutions of the reference and test preparations using a non-chelating, appropriately buffered solution *tris(hydroxymethyl)aminomethane* or *imidazole*, containing 1.0 per cent of *human or bovine albumin*. Prepare at least 2 dilution series of at least 3 further dilutions for each material.

Prepare the dilutions such that the final factor VIII concentration in the reaction mixture is preferably below 0.01 IU per ml, during the step of factor Xa generation.

Prepare a control solution that includes all components except factor VIII.

Prepare all dilutions in plastic tubes and use immediately.

**Step 1.** Mix prewarmed dilutions of the factor VIII reference preparation and of the preparation under examination with an appropriate volume of the *prewarmed coagulation factor reagent* or a combination of its separate constituents, and incubate the mixture in plastic tubes or microplate wells at 37°. Allow the activation of factor X to proceed for a suitable time, terminating the reaction (step 2) when the factor Xa concentration has reached approximately 50.0 per cent of the maximal (plateau) level. Appropriate activation times are usually between 2 to 5 minutes.

**Step 2.** Terminate the activation by addition of a *prewarmed reagent containing a chromogenic substrate*. Quantify the rate of substrate cleavage, which must be linear with the concentration of factor Xa formed, by measuring the absorbance change at an appropriate wavelength using a spectrophotometer, either monitoring the absorbance continuously, thus allowing the initial rate of substrate cleavage to be calculated, or terminating the hydrolysis reaction after a suitable interval by lowering the pH by addition of a suitable reagent, such as a 50.0 per cent v/v solution of *acetic acid*, or a *1 M pH 3 citrate buffer solution*. Adjust the hydrolysis time to achieve a linear development of chromophore over time. Appropriate hydrolysis times are usually between 3 to 15 minutes, but deviations are permissible if better linearity of the dose-response relationship is thus obtained.

Calculate the potency of the test preparation by the usual statistical methods.

### 2.8.8. Assay of Human Coagulation Factor IX

The principle of the assay is to measure the ability of a factor IX preparation to reduce the prolonged coagulation time of factor IX-deficient plasma. The reaction is accelerated by addition of a reagent containing phospholipid and a contact activator, e.g. kaolin, silica or ellagic acid. The potency is assessed by comparing the dose-response curve of the preparation under examination to that of a reference preparation, calibrated in International Units.

The International Unit is the factor IX activity of a stated amount of the International Standard, which consists of a freeze-dried concentrate of human coagulation factor IX. The equivalence in International Units of the International Standard is stated by the World Health Organisation.

*Human coagulation factor IX concentrate reference*

*preparation* is calibrated in International Units by comparison with the International Standard.

Reconstitute separately the preparation under examination and the reference preparation as stated on the label and use immediately. Where applicable, determine the amount of heparin present (2.8.10) and neutralise the heparin, for example by addition of *protamine sulphate* (10 µg of protamine sulphate neutralises 1 IU of heparin). Predilute the preparation under examination and the reference preparation in factor IX-deficient plasma (for example *plasma substrate*) to produce solutions containing 0.5-2.0 IU per ml. Prepare at least 3 dilutions for each material, preferably in duplicate, using a suitable *buffer solution* (for example *imidazole buffer solution pH 7.3*) containing 1.0 per cent w/v of bovine or human albumin. Use these dilutions immediately.

Use an apparatus suitable for measurement of coagulation times or carry out the assay with incubation tubes maintained in a water-bath at 37°. Place in each tube 0.1 ml of factor IX-deficient plasma (for example *plasma substrate*) and 0.1 ml of one of the dilutions of the reference preparation or of the preparation under examination. Add to each tube 0.1 ml of a suitable *activated partial thromboplastin Time (APTT) reagent containing phospholipid and contact activator* and incubate the mixture for a recommended time at 37°. To each tube, add 0.1 ml of a 0.37 per cent w/v solution of *calcium chloride* previously heated to 37°. Using a timer, measure the coagulation time, i.e. the interval between the moment of the addition of the calcium chloride and the first indication of the formation of fibrin. The volumes given above may be adapted to the *APTT reagent* and apparatus used. Calculate the potency using the usual statistical methods.

### 2.8.9. Assay of Human Coagulation Factor X

Human coagulation factor X is assayed following specific activation to form factor Xa. Factor Xa is estimated by comparing its activity in cleaving a specific chromogenic peptide substrate with the same activity of the International Standard or of a reference preparation calibrated in International Units.

The International Unit is the factor X activity of a stated amount of the International Standard which consists of a freeze-dried concentrate of human coagulation factor X. The equivalence in International Units of the International Standard is stated by the World Health Organisation.

The chromogenic assay method consists of 2 steps: snake venom-dependent activation of factor X, followed by enzymatic cleavage of a chromogenic factor Xa substrate to form a chromophore that can be quantified spectrophotometrically. Under appropriate assay conditions, there is a linear relation between factor Xa activity and the cleavage of the chromogenic substrate.

#### Reagents

**Russell's viper venom specific factor X activator (RVV).** A protein derived from the venom of Russell's viper (*Vipera russelli*) which specifically activates factor X. Reconstitute according to the manufacturer's instructions. Store the reconstituted preparation at 4° and use within 1 month.

**Factor Xa chromogenic substrate.** Specific chromogenic substrate for factor Xa such as: *N- $\alpha$ -benzyloxycarbonyl-D-arginyl-L-glycyl-L-arginine-4-nitroanilide dihydrochloride*, *N-benzoyl-L-isoleucyl-L-glutamyl-glycyl-L-arginine-4-nitroanilide hydrochloride*, *methanesulphonyl-D-leucyl-glycyl-L-arginine-4-nitroanilide*, *methoxycarbonyl-D-cyclohexylalanyl-glycyl-L-arginine-4-nitroanilide acetate*. Reconstitute according to the manufacturer's instructions.

**Dilution buffer.** Solution containing 0.37 per cent w/v of *tris(hydroxymethyl)aminomethane*, 1.8 per cent w/v of *sodium chloride*, 0.21 per cent w/v of *imidazole*, 0.002 per cent w/v of *hexadimethrine bromide* and 0.1 per cent w/v of *bovine albumin* or *human albumin*. Adjust to pH 8.4 if necessary using *hydrochloric acid*.

#### Method

**Test solution.** Dilute the preparation under examination with *dilution buffer* to obtain a solution containing 0.18 IU of factor X per ml. Prepare at least 3 further dilutions with same solvent.

**Reference solution.** Dilute the reference preparation with *dilution buffer* to obtain a solution containing 0.18 IU of factor X per ml. Prepare at least 3 further dilutions with same solvent.

Warm all solutions to 37° in a water-bath shortly before the test.

The following working conditions apply to microtitre plates. If the assay is carried out in tubes, the volumes are adjusted while maintaining the proportions in the mixture.

Using a microtitre plate maintained at 37°, add 12.5 µl of each dilution of the test solution or the reference solution to each of a series of wells. To each well add 25 µl of RVV and incubate for exactly 90 seconds. To each well add 150 µl of factor Xa chromogenic substrate, diluted 1 in 6 in *dilution buffer*.

Read the rate of change of absorbance (2.4.7) (at 405 nm continuously over a period of 3 minutes and obtain the mean rate of change of absorbance (ÅÅ per minutes). If continuous monitoring is not possible, read the absorbance at 405 nm at suitable consecutive intervals, for instance 40 seconds, plot the absorbances against time on a linear graph and calculate ÅÅ per minute as the slope of the line. From the ÅÅ per minute values of each individual dilution of standard and test preparations, calculate the potency of the preparation under examination and check the validity of the assay by the usual statistical methods.



### 2.8.10. Assay of Heparin in Coagulation Factors

Heparin is assayed as a complex with antithrombin III (AT) via its inhibition of coagulation factor Xa (anti-Xa activity). An excess of AT is maintained in the reaction mixture to ensure a constant concentration of the heparin-AT complex. Factor Xa is neutralised by the heparin-AT complex and the residual factor Xa hydrolyses a specific chromogenic peptide substrate to release a chromophore. The quantity of chromophore is inversely proportional to the activity of the heparin.

**Factor Xa chromogenic substrate.** Specific chromogenic substrate for factor Xa such as: *N-benzoyl-L-isoleucyl-L-glutamyl-glycyl-L-arginine-4-nitroanilide hydrochloride*. Reconstitute according to the manufacturer's instructions.

**Dilution buffer.** 0.605 per cent w/v solution of *tris(hydroxymethyl)aminomethane*. Adjust to pH 8.4 if necessary using *hydrochloric acid*.

**Test solution.** Dilute the preparation under examination with *dilution buffer* to obtain a solution expected to contain 0.1 IU of heparin per ml.

**Reference solution.** Dilute the heparin reference preparation with *dilution buffer* to obtain a solution containing 0.1 IU of heparin per ml.

The following working conditions apply to microtitre plates. If the assay is carried out in tubes, the volumes are adjusted while maintaining the proportions in the mixture.

Warm all solutions to 37° in a water-bath shortly before the test.

Distribute in a series of wells, 20 µl of *normal human plasma* and 20 µl of *antithrombin III solution*. Add to the wells a series of volumes (20 µl, 60 µl, 100 µl and 140 µl) of the test solution or the reference solution and make up the volume in each well to 200 µl using *dilution buffer* (0.02-0.08 IU of heparin per ml in the final reaction mixture).

**End-point method.** Transfer 40 µl from each well to a second series of wells, add 20 µl of *bovine factor Xa solution* and incubate at 37° for 30 seconds. Add 40 µl of a 1 mmol per litre solution of factor Xa chromogenic substrate and incubate at 37° for 3 minutes. Terminate the reaction by lowering the pH by the addition of a suitable reagent, such as a 20.0 per cent v/v solution of *glacial acetic acid* and measure the absorbance (2.4.7) at 405 nm. Appropriate reaction times are usually between 3 to 15 minutes, but deviations are permissible if better linearity of the dose-response relationship is thus obtained.

**Kinetic method.** Transfer 40 µl from each well to a second series of wells, add 20 µl of *bovine factor Xa solution* and incubate at 37° for 30 seconds. Add 40 µl of a 2 mmol per litre solution of *factor Xa chromogenic substrate*, incubate at 37° and measure the rate of substrate cleavage by continuous

measurement of the absorbance change at 405 nm (2.4.7), thus allowing the initial rate of substrate cleavage to be calculated. This rate must be linear with the concentration of residual factor Xa.

Check the validity of the assay and calculate the heparin activity of the test preparation by the usual statistical methods for a slope-ratio assay.

### 2.8.11. Determination of ABO Blood Group and Rh Group

#### A. Determination of ABO Blood Group of Blood Donors

##### ABO Blood-grouping Reagents

**Source.** ABO Blood-grouping Reagents are derived from the sera or defibrinated plasma of selected persons of appropriate ABO blood group who may have been deliberately immunised with either red corpuscles or group-specific substance of the appropriate blood group or groups, or derived from the sera of lower animals after immunisation or from cultures of mammalian lymphocytes. They are to be tested with negative results for the presence of hepatitis B surface antigen and antibodies to HIV-I and HIV-II by suitable sensitive methods approved by the appropriate authority.

**Description.** ABO Blood-grouping Reagents are of three types, namely Anti-A Blood-grouping Reagents, Anti-B Blood-grouping Reagent and Anti A, B (Group O) Blood-grouping Reagent. They may be issued as liquids or they may be prepared by reconstitution from the dried reagents.

Liquid Anti-A, or Anti-B, or Anti-A,B (Group O) reagents are clear or slightly opalescent yellowish or colourless fluids without turbidity. Anti-A reagent is artificially coloured blue or blue-green; anti-B reagent is artificially coloured yellow. They may contain a suitable antimicrobial preservative. Dried reagents are pale yellow powders or friable solids and are used after reconstitution.

**Properties.** Anti-A Blood-grouping Reagent agglutinates human red corpuscles containing A antigens, including sub-groups A<sub>1</sub>, A<sub>2</sub>, A<sub>1</sub>B and A<sub>2</sub>B, but rarely agglutinates those red corpuscles classified as A<sub>x</sub>. It does not agglutinate human red corpuscles which do not contain A agglutinogens, i.e. red blood corpuscles of groups O and B. It also does not agglutinate group O or group B red corpuscles coated with IgG.

Anti-B Blood-grouping Reagent agglutinates human red corpuscles containing B antigens, i.e. red corpuscles of blood groups B and AB including sub-groups A<sub>1</sub>B and A<sub>2</sub>B. It does not agglutinate human red corpuscles, which do not contain B agglutinogens, i.e. red blood corpuscles of groups O, A<sub>1</sub> and A<sub>2</sub>. It also does not agglutinate group O or group red Corpuscles coated with IgG.

Anti A,B (Group O) Blood-grouping Reagent agglutinates human red corpuscles containing A or B antigens, i.e. it agglutinates red corpuscles of blood groups A,B and AB including sub-groups  $A_1$ ,  $A_2$ ,  $A_x$ ,  $A_1B$ ,  $A_2B$ , and  $A_xb$ . It does not agglutinates human red corpuscles which do not contain A or B antigens, i.e. red corpuscles of blood group O. it also does not agglutinates group O red corpuscles coated with IgG

Anti-A, Ant-B and Anti-A, B (Group O) Blood grouping Reagents are shown not to contain antibodies to serum protein factors Gm or Km.

*ABO Blood-grouping Reagents, reconstituted where necessary as stated on the label, comply with the following requirements.*

**Avidity.** A mixture of 1 volume of the reagent with 1 volume of a 5.0 to 10.0 per cent v/v suspension of human red corpuscles of each group or sub-group should not take more than twice the time that is taken for agglutination to appear first to the unaided eye when compared with the time taken when the appropriate International Standard of Blood-typing Serum or another suitable reference preparation of equivalent avidity in place of the reagent under examination.

*Anti-A Blood-grouping Reagent* - Use human red corpuscles of sub-groups  $A_1$ ,  $A_2$ ,  $A_1B$  and  $A_2B$ ,. The appropriate International Standard is that for Anti-A blood-typing serum.

*Anti-B Blood-grouping Reagent* — Use human red corpuscles of sub-group B. The appropriate International Standard is that for Anti-B blood-typing serum.

*Anti A,B (Group O) Blood-grouping Reagent* — Use human red corpuscles of sub-groups  $A_1$ ,  $A_2$  and of group B. The appropriate International Standard is that for Anti-A,B blood-typing serum.

The following are the minimum requirements for the time taken by anti-A serum to show naked eye agglutination when mixed on a slide with an equal volume of a 5.0 to 10.0 per cent v/v suspension of  $A_1$ ,  $A_2$ , and  $A_2B$  cells.

<i>Serum</i>	<i>Test corpuscles</i>	<i>Titre</i>
Anti-A	$A_1$	15 seconds
	$A_2$	30 seconds
	$A_2B$	45 seconds
Anti-B	B	15 seconds

**Potency.** The potency of an ABO Blood-grouping Reagent is determined by comparing its “saline agglutinin” antibody activity with that of the appropriate International Standard of Blood-typing serum or with that of another suitable reference preparation the potency of which has been determined in relation to the appropriate International Standard.

The determination is carried out by simultaneously titrating the reagent under examination and the reference preparation against suspension of human red corpuscles of the groups or sub-groups given below.

Anti-A, Anti-B, and Anti A, B (Group O) Blood-grouping Reagents should contain not less than 64 Units of the respective antibody per ml, i.e. for each type of red corpuscle against which it is titrated, the titre of the reagent under examination is not less than one quarter of that of the appropriate reconstituted International Standard irrespective of the actual titres obtained. (The International Standard for Blood-typing serum may be obtained from the WHO International Laboratory for Biological Standards, Central Laboratory, Netherlands Red Cross Blood Transfusion Service, Plesmanlaan 125, Amsterdam, The Netherlands).

The following are the minimum requirements for titre of anti-A serum with  $A_1$ ,  $A_2$ , and  $A_2B$  corpuscles and of anti-B serum with B corpuscles.

<i>Serum</i>	<i>Test corpuscles</i>	<i>Titre</i>
Anti-A	$A_1$	256
	$A_2$	128
	$A_2B$	64
Anti-B	B	256

**Sterility** (2.2.11). Complies with the tests for sterility.

**Storage.** ABO Blood-grouping Reagents should be stored in sterile, light-resistant containers sealed so as to exclude microorganisms.

Liquid ABO Blood-grouping Reagents which do not contain an antimicrobial preservative should be kept frozen, preferably at a temperature below  $-30^\circ$  unless the preservative has been shown to be innocuous to the reagent in the frozen state.

Liquid ABO Blood-grouping Reagents containing an antimicrobial preservative should be kept at a temperature between  $2^\circ$  and  $8^\circ$ .

Dried ABO Blood-grouping Reagents should be kept at a temperature not higher than  $20^\circ$ .

**Labelling.** The label states (1) the name “Anti-A Blood-grouping Reagent” printed on blue paper, “Anti-B Blood-grouping Reagent” printed on yellow paper, or “Anti-A,B (Group O) Blood-grouping Reagent” as appropriate; (2) the number of Units of the relevant antibody or antibodies per ml; (3) the batch number; (4) the quantity in the container; (5) the date after which the preparation may not be expected to retain its activity; (6) the storage conditions; (7) for a liquid reagent containing an antimicrobial preservative, the name and concentration of the preservative used, and that the reagent should not be frozen unless the preservative has been shown

to be innocuous to the reagents in the frozen state; (8) for dried reagents the nature and volume of the liquid to be used for reconstitution.

### Method

The blood is examined both for agglutinogens of the red corpuscles and for agglutinins in the serum. A few ml of fresh blood, without anticoagulant, is allowed to clot in a narrow test-tube, and the serum removed. The clot or a small part of it is stirred with *saline solution*, the resulting suspension centrifuged and the corpuscles resuspended in *saline solution* to make a 2.0 to 3.0 per cent v/v suspension of packed corpuscles.

**Test for agglutinogens.** The test is conveniently made in lipless tubes (50 mm x 6 mm), each containing 0.04 ml volumes of diagnostic serum, of the red corpuscles suspension and of *saline solution* (to avoid nonspecific agglutination) delivered from calibrated Pasteur pipettes. One tube contains anti-A serum and a second contains anti-B serum.

It is advisable to control the specificity of anti-A serum and anti-B serum by testing them with red corpuscles of known groups A, B and O.

The tubes are shaken and left at room temperature for 2 hours, covered with cylindrical glass caps to prevent evaporation and to protect the contents. The caps are then removed and each tube flicked with a finger to disperse the deposit of corpuscles. The contents of tubes in which no obvious agglutination has occurred are examined microscopically at a magnification of x50 to x100, spread evenly on a slide with the stem of a Pasteur pipette. The reaction is scored as follows.

++++	=	Complete agglutination into one or two large clumps.
+++	=	Numerous clumps clearly visible to the naked eye.
++	=	Granularity just visible to the naked eye; very big clumps and unagglutinated corpuscles seen under the microscope.
+	=	Not quite such big clumps; numerous unagglutinated corpuscles.
(+)	=	Clumps of 8 to 12 corpuscles.
w	=	A definite but weak reaction in which there is a uniform distribution of very small clumps of 4 to 6 corpuscles.
?	=	Uneven distribution of corpuscles with no definite clumps.
-	=	All corpuscles separate and evenly distributed.

In test of red corpuscles a reaction less than + is unlikely to be due to A or B agglutinogens, and the corpuscles should be tested.

**Test for agglutinins.** The serum of the blood under examination is similarly tested against group A and B red corpuscles, 0.04 ml of the suspension and 0.04 ml of the undiluted serum being used. In this test, small reactions are frequent, and in about 50.0 per cent of infants under 1 year old, either one or both of the agglutinins to be expected on the basis of agglutinogens of the red corpuscles, are not found. In all bloods, a “w” reaction is considered to be true, a “?” requires a retest. When the expected agglutinins are not disclosed after retest, the diagnosis is based on the agglutinogens of the red corpuscles.

**Slide or tile method.** Blood obtained from the finger-prick is diluted with *saline solution* so as to give a suspension containing approximately 5.0 per cent v/v red corpuscles. Oxalated blood is also suitable for this purpose.

Take two plain glass slides marked A and B, place one drop of red cell suspension on each of them, add one drop of anti-A serum on the slide marked B. Mix with a glass rod and gently rock the slides to and fro. The agglutinate appears almost at once with the appropriate serum.

Negative readings should not be taken until the preparation has stood at least for 10 minutes. The reaction is visible to the naked eye but a hand lens or a low power microscope may be employed in doubtful cases. When a large number of blood samples have to be tested for blood groups, a long porcelain or opal glass tile may be employed in place of glass slides.

**Weak reactions with anti-A serum in group AB.** Care must be taken in making the diagnosis of group B because the reaction of anti-A serum with the A agglutinogens is often weak when the B agglutinin is also present on the corpuscles; group AB corpuscles may therefore be falsely diagnosed as group B corpuscles. This is particularly true of the sub-group A, B in which the reactions of the A agglutinins are always weak. The examination of the serum for agglutinins does not necessarily serve as a check since the serum of a number of A, B persons contains the agglutinin anti-A, which reacts with A<sub>1</sub> but not with A<sub>2</sub> corpuscles. Since A<sub>1</sub> corpuscles are used to check the serum, agglutination may occur and the diagnosis of group B corpuscles be apparently confirmed. The mistake is, however, unlikely to arise if an anti-A serum is used which has been tested for its capacity to react with known AB corpuscles. As an additional check the serum from every blood that has been shown by determination of its agglutinogen and agglutinin content to belong to group B is tested against known A<sub>2</sub> corpuscles. If there is a reaction it is clear that the serum must contain the agglutinin alpha, which reacts with A<sub>2</sub> as well as with A<sub>1</sub> corpuscles. The serum, therefore, cannot have come from an A<sub>1</sub>B or an A<sub>2</sub>B person and must have come from a group B person. The diagnosis that corpuscles belong to group B should be made unless the serum reacts with A<sub>2</sub> corpuscles.

ABO group of blood is determined from the antigens on the red corpuscles and the antibodies in the serum or plasma. Collect a few ml of blood without anticoagulant in a test-tube and allow to clot. Remove the serum and prepare a 2.0 to 3.0 per cent suspension of red corpuscles in *saline solution*.

**Test for antigens.** Mix 1 volume of the red corpuscle suspension with 1 volume of *anti-A blood-grouping reagent*, *anti-B blood-grouping reagent* and *anti-A,B (group O) blood-grouping reagent*, the specificities of which have been demonstrated by testing with known red corpuscles of group A,B and O. Allow the mixture in the test-tube to stand at room temperature for 1 to 2 hours and then tap them gently to disperse the deposit of corpuscles. Examine the contents of the tubes microscopically for agglutination.

**Test for antibodies.** Mix separate portions of the serum or plasma with suspension of human red corpuscles of group A (sub-groups A<sub>1</sub> and A<sub>2</sub>), group B and group O and determine the antibodies present by examination of the resulting pattern of deposit of corpuscles. As antibodies are incompletely developed in children under 1 year of age, the blood group of the child is based solely on the antigens present on red corpuscles.

## B. Determination of Rh Group of Donors

### Rh Blood-grouping Reagents

**Source.** Rh Blood-grouping Reagents are derived from the sera or defibrinated plasma of one or more persons immunised by Rh system or from cultures of mammalian lymphocytes. The material to be used must be tested with negative results for the presence of hepatitis B surface antigens and antibodies to HIV I and HIV-II by suitable sensitive methods approved by the appropriate authority.

**Description.** Rh Blood-grouping Reagents may be issued as liquids or they may be prepared by reconstitution from the dried reagents. Liquid reagents are clear or faintly opalescent, yellowish or colourless fluids without turbidity. They may contain a suitable antimicrobial preservative. Dried reagents are pale yellow powders or friable solids.

Rh Blood-grouping Reagents are of four types, namely IgM Anti-D Blood-grouping Reagent, IgG Anti-D Blood grouping Reagent, Anti-C Blood-grouping Reagent and Anti-E Blood-grouping Reagent.

**Properties.** Blended IgG and IgM monoclonal reagents are preferably used for Rh blood-grouping in blood banks. Anti-D, Anti-C and Anti-E Blood-grouping Reagent should be shown not to agglutinate or to coat any of a comprehensive panel of corpuscles that do not contain the respective antigens.

*Rh Blood-grouping Reagents, reconstituted where necessary as stated on the label, comply with the following requirements.*

**Potency.** *IgM anti-D Blood-grouping Reagent* - It contains anti-D as a "saline agglutinin" in such quantities that it gives a positive reaction at a dilution of 1 in 32 against corpuscles known to contain the D antigens.

*IgG anti-D Blood-grouping Reagent* - The potency of IgG anti-D Blood-grouping Reagent is determined by comparing its "albumin agglutinin" antibody activity with that of the appropriate International Standard of Blood-typing serum or with that of another suitable reference preparation the potency of which has been determined in relation to the appropriate International Standard.

The determination is carried out by simultaneously titrating the reagent under examination and the reference preparation against suspension of human red corpuscles containing the D antigens.

IgG anti-D Blood-grouping Reagent contains not less than 32 Units of anti-D antibody per ml, i.e. the titre of the reagent under examination is not less than one-half of that of the appropriate reconstituted International Standard irrespective of the titre obtained.

*Anti-C Blood-grouping Reagent* - It contains anti-C antibody in such quantities that it gives a positive reaction at a dilution of 1 in 8 with red corpuscles known to contain the C antigens.

*Anti-E Blood-grouping Reagent* - It contains anti-E antibody in such quantities that it gives a positive reaction at a dilution of 1 in 8 with red corpuscles known to contain the E antigens.

**Sterility** (2.2.11). Complies with the tests for sterility.

**Storage.** Rh Blood-grouping reagents should be kept in sterile containers sealed so as to exclude micro-organisms.

Liquid Rh Blood-grouping Reagent which do not contain antimicrobial preservative should be kept frozen, preferably at a temperature below -30°

Liquid Rh Blood-grouping Reagents containing an antimicrobial preservative should be kept at a temperature between 2° and 8° ; they should not be frozen unless the antimicrobial preservative has been shown to be innocuous to the reagent in the Frozen state.

Dried Rh Blood-grouping Reagents should be kept at a temperature not higher than 20°.

**Labelling.** The label states (1) the name "IgM Anti-D Blood-grouping Reagent", "IgG Anti-D Blood-grouping Reagent", "Anti-C Blood-grouping Reagent" or "Anti-E Blood-grouping Reagent" as appropriate; (2) the agglutination titre; (3) the batch number; (4) the date after which the preparation may not be expected to retain its activity; (5) the storage conditions; (6) for a liquid reagent containing an antimicrobial preservative, the name and concentration of the preservative used and that the reagent must not be frozen unless the



preservative has been shown to be innocuous to the reagent in the frozen state; (7) for dried reagents the nature and volume of the liquid to be used for reconstitution.

**Method.** Since the haemagglutinins of the Rh system are present in human blood only in pathological conditions, it is necessary to depend solely on the reaction of the red corpuscles in order to determine the Rh group of a specimen of blood. Red corpuscles are obtained either by bleeding into a 3.0 per cent w/v solution of *sodium citrate* or by re-suspending in *saline solution* to give a suspension containing approximately 2.0 per cent v/v suspension of packed corpuscles.

In order to select Rh negative Blood, the untested donor blood is first tested with anti-D Rh serum and, in order to conserve these very rare sera, only those bloods which are unagglutinated are further tested with anti-C Rh serum and anti-E Rh serum.

For economical routine work, 0.01-ml volumes each of serum and corpuscles suspension are used, though for inexperienced workers, 0.04-ml volumes are preferable. With a Pasteur pipette, graduated at 0.01 ml intervals, 0.01 ml of anti-D Rh serum is deposited at the bottom of lipless test-tubes (50 mm x 6 mm); 0.01 ml of red corpuscles suspension is then deposited on the wall of the tube about 4 mm above the serum and the two are mixed and incubated for 2 hours at 37°. Control test of the serum are made with D-positive and D-negative corpuscles. For reading, the deposited corpuscles are gently taken up with a Pasteur pipette, spread evenly on a slide with the stem of the pipette, and examined microscopically at a magnification of x50 to x100. D-positive corpuscles form large clumps whereas D-negative corpuscles are unagglutinated. The tests with anti-C Rh serum and anti-E Rh serum are made similarly but, since the agglutination is usually weak, the deposited corpuscles must be transferred to the slide with minimum manipulation.

It is advisable to control the specificity of each anti-Rh serum used by testing it with red corpuscles of Rh groups that should react positively and of Rh groups that should react negatively with each serum.

### 2.8.12. Determination of Haemoglobin by Photometry

The determination of haemoglobin in blood is done by the measurement of colour of cyanmethaemoglobin obtained by conversion of haemoglobin to cyanmethaemoglobin by means of a special reagent.

#### Special Reagent

**Ferricyanide-cyanide reagent.** Dissolve 0.2 g of *potassium ferricyanide*, 50 mg of *potassium cyanide* and 0.14 g of *potassium dihydrogen phosphate* in sufficient *water* to produce 1,000 ml. Check the pH and adjust, if necessary, to  $7.2 \pm 0.2$ . Store in a polyethylene bottle in the dark at a temperature below 20°.

*NOTE* — *The solution should not be frozen.*

#### Method

Pipette 0.02 ml of the substance under examination into a stoppered tube, add 4.0 ml of *ferricyanide cyanide reagent* and mix well. Allow to stand for 10 minutes and measure the absorbance (2.4.7) of the resulting solution at about 540 nm, using as blank the *ferricyanide-cyanide reagent*. Calculate the content of haemoglobin from the absorbance obtained by carrying out the determination simultaneously using a suitable volume of *cyanmethaemoglobin RS* and from the declared content of haemoglobin in *cyanmethaemoglobin RS*

### 3. REFERENCE DATA

- |      |                                   |      |
|------|-----------------------------------|------|
| 3.1. | Infrared Reference Spectra        | .... |
| 3.2. | Thin-Layer Chromatograms of Herbs | .... |
| 3.3. | Liquid Chromatograms of Herbs     | .... |

## 4. REAGENTS AND SOLUTIONS

4.1.	Buffer solutions	....
4.2.	General Reagent	....
4.3.	Indicators and Indicator Test Papers	....
4.4.	Standard Solutions	....
4.5.	Volumetric Reagents and Solutions	....

## 4.1. Buffer Solutions

### A. Standard Buffer Solutions

Standard Buffer Solutions are solutions of standard pH. They are used for reference purposes in pH measurements and for carrying out many pharmacopoeial tests which require adjustments to or maintenance of a specified pH. They may be prepared by the methods described below. The preparation of special buffer solutions is described in the sections in which their use is specified as in the *microbiological assay of antibiotics* or in the individual monographs where the use of such solutions is indicated.

The reagents required for the preparation of standard buffer solutions are described in Appendix 4.2. All the crystalline reagents except boric acid should be dried at 110° to 120° for 1 hour before use. *Carbon dioxide-free water* should be used for preparing buffer solutions and wherever *water* is mentioned for preparation of such solutions the use of *carbon dioxide-free water* is implied. The prepared solutions should be stored in chemically resistant, glass-stoppered bottles of alkali-free glass and used within 3 months of preparation. Any solution which has become cloudy or shows any other evidence of deterioration should be discarded.

Standard buffer solutions for various ranges of pH values 1.2 to 10.0 may be prepared by appropriate combinations of 0.2 M hydrochloric acid or 0.2 M sodium hydroxide and of solutions described below, used in the proportions shown in the accompanying tables. The standard pH values given in the tables and elsewhere in the Appendix are considered to be reproducible within  $\pm 0.02$  Unit at 25°.

**1. Boric Acid and Potassium Chloride, 0.2 M:** Dissolve 12.366 g of *boric acid* and 14.911 g of *potassium chloride* in *water* and dilute with *water* to 1000 ml.

**2. Disodium Hydrogen Phosphate, 0.2 M:** Dissolve 71.630 g of *disodium hydrogen phosphate* in *water* and dilute with *water* to 1000 ml.

**3. Hydrochloric Acid, 0.2 M:** *Hydrochloric acid* diluted with *water* to contain 7.292 g of HCl in 1000 ml. Standardise as directed in Appendix 4.4.

**4. Potassium Chloride, 0.2 M:** Dissolve 14.911 g of *potassium chloride* in *water* and dilute with *water* to 1000 ml.

**5. Potassium Dihydrogen Phosphate, 0.2 M:** Dissolve 27.218 g of *potassium dihydrogen phosphate* in *water* and dilute with *water* to 1000 ml.

**6. Potassium Hydrogen Phthalate, 0.2 M:** Dissolve 40.846 g of *potassium hydrogen phthalate* in *water* and dilute with *water* to 1000 ml.

**7. Sodium Hydroxide, 0.2 M:** Dissolve *sodium hydroxide* in *water* to produce a 40 to 60 per cent w/v solution and allow to

stand. Taking precautions to avoid absorption of carbon dioxide, siphon off the clear supernatant liquid and dilute with *carbon dioxide-free water* a suitable volume of the liquid to contain 8.0 g of NaOH in 1000 ml. Standardise as directed in Appendix 4.4.

*NOTE* — 0.2 M Sodium hydroxide must not be used later than one month after preparation.

### Composition of Standard Buffer Solutions

**Hydrochloric Acid Buffer:** Place 50.0 ml of the 0.2 M *potassium chloride* in a 200-ml volumetric flask, add the specified volume of 0.2 M *hydrochloric acid* (see Table 1) and then add *water* to volume.

Table 1

pH	0.2 M HCl, ml	pH	0.2 M HCl, ml
1.2	85.0	1.8	20.4
1.3	67.2	1.9	16.2
1.4	53.2	2.0	13.0
1.5	41.4	2.1	10.2
1.6	32.4	2.2	7.8
1.7	26.0		

**Acid Phthalate Buffer:** Place 50.0 ml of 0.2 M *potassium hydrogen phthalate* in a 200-ml volumetric flask, add the specified volume of 0.2 M *hydrochloric acid* (see Table 2) and then add *water* to volume.

Table 2

pH	0.2 M HCl, ml	pH	0.2 M HCl, ml
2.2	49.5	3.2	15.7
2.4	42.2	3.4	10.4
2.6	35.4	3.6	6.3
2.8	28.9	3.8	2.9
3.0	22.3	4.0	0.1

**Neutralised Phthalate Buffer; Phthalate Buffer:** Place 50.0 ml of 0.2 M *potassium hydrogen phthalate* in a 200-ml volumetric flask, add the specified volume of 0.2 M *sodium hydroxide* (see Table 3) and then add *water* to volume.

Table 3

pH	0.2 M NaOH, ml	pH	0.2 M NaOH, ml
4.2	3.0	5.2	28.8
4.4	6.6	5.4	34.1
4.6	11.1	5.6	38.8
4.8	16.5	5.8	42.3
5.0	22.6		

**Phosphate Buffer:** Place 50.0 ml of 0.2 M *potassium dihydrogen phosphate* in a 200-ml volumetric flask, add the



specified volume of 0.2 M sodium hydroxide (see Table 4) and then add water to volume.

Table 4

pH	0.2 M NaOH, ml	pH	0.2 M NaOH, ml
5.8	3.6	7.0	29.1
6.0	5.6	7.2	34.7
6.2	8.1	7.4	39.1
6.4	11.6	7.6	42.4
6.6	16.4	7.8	44.5
6.8	22.4	8.0	46.1

**Alkaline Borate Buffer:** Place 50.0 ml of 0.2 M boric acid and potassium chloride in a 200-ml volumetric flask, add the specified volume of 0.2 M sodium hydroxide (see Table 5) and then add water to volume.

Table 5

pH	0.2 M NaOH, ml	pH	0.2 M NaOH, ml
8.0	3.9	9.2	26.4
8.2	6.0	9.4	32.1
8.4	8.6	9.6	36.9
8.6	11.8	9.8	40.6
8.8	15.8	10.0	43.7
9.0	20.8		

*NOTE* — In this Pharmacopoeia standard buffer solutions are referred to as “buffer solution pH....” or “buffer pH....”

## B. Other Buffer solutions

**Acetate Buffer pH 2.8:** Dissolve 4 g of anhydrous sodium acetate in about 840 ml of water, add sufficient glacial acetic acid to adjust the pH to 2.8 (about 155 ml) and dilute with water to 1000 ml.

**Acetate Buffer pH 3.4:** Mix 50 ml of 0.1 M sodium acetate with 950 ml of 0.1 M acetic acid.

**Acetate Buffer pH 3.5:** Dissolve 25 g of ammonium acetate in 25 ml of water and add 38 ml of 7 M hydrochloric acid. Adjust the pH to 3.5 with either 2 M hydrochloric acid or 6 M ammonia and dilute with water to 100 ml.

**Acetate Buffer pH 3.7:** Dissolve 10 g of anhydrous sodium acetate in 300 ml of water, adjust to pH to 3.7 with glacial acetic acid and dilute with water to 1000 ml. Before use adjust to pH 3.7, if necessary, with glacial acetic acid or anhydrous sodium acetate, as required.

**Acetate Buffer pH 4.0:** Place 2.86 ml of glacial acetic acid and 1.0 ml of a 50 per cent w/v solution of sodium hydroxide in a 1000-ml volumetric flask, add water to volume and mix. Adjust the pH, if necessary.

**Acetate Buffer pH 4.4:** Dissolve 136 g of sodium acetate and 77 g of ammonium acetate in water and dilute with water to 1000 ml. Add 250 ml of glacial acetic acid and mix.

**Acetate Buffer pH 4.6:** Dissolve 5.4 g of sodium acetate in 50 ml of water, add 2.4 ml of glacial acetic acid and dilute with water to 100 ml. Adjust the pH, if necessary.

**Acetate Buffer pH 4.7:** Dissolve 8.4 g of sodium acetate and 3.35 ml of glacial acetic acid in sufficient water to produce 1000 ml. Adjust the pH, if necessary.

**Acetate Buffer pH 5.0:** Dissolve 13.6 g of sodium acetate and 6 ml of glacial acetic acid in sufficient water to produce 1000 ml. Adjust the pH, if necessary.

**Acetate Buffer pH 5.5:** Dissolve 272 g of sodium acetate in 500 ml of water by heating to 35°, cool and add slowly 50 ml of glacial acetic acid and sufficient water to produce 1000 ml. Adjust the pH, if necessary.

**Acetate Buffer pH 6.0:** Dissolve 100 g of ammonium acetate in 300 ml of water, add 4.1 ml of glacial acetic acid, adjust the pH, if necessary, using 10 M ammonia or 5 M acetic acid and dilute with water to 500 ml.

**Acetate Buffer Solution:** Dissolve 14 g of potassium acetate and 20.5 ml of glacial acetic acid in sufficient water to produce 1000 ml.

**Acetic Acid-Ammonium Acetate Buffer:** Dissolve 77.1 g of ammonium acetate in water, add 57 ml of glacial acetic acid and dilute with water to 1000 ml.

**Acetic Ammonia Buffer pH 3.7, Ethanolic:** To 15 ml of 5 M acetic acid add 60 ml of ethanol (95 per cent) and 24 ml of water. Adjust the pH to 3.7 with 10 M ammonia and dilute with water to 100 ml.

**Acetone Solution, Buffered:** Dissolve 8.15 g of sodium acetate and 42 g of sodium chloride in water, add 68 ml of 0.1 M hydrochloric acid and 150 ml of acetone and dilute with water to 500 ml.

**Albumin Phosphate Buffer pH 7.2; Phosphate-albumin Buffered Saline pH 7.2:** Dissolve 10.75 g of disodium hydrogen phosphate, 7.6 g of sodium chloride and 10 g of bovine albumin in sufficient water to produce 1000 ml. Before use adjust to pH 7.2 with 2M sodium hydroxide or a 10 per cent w/v solution of phosphoric acid as required.

**Ammonia-Ammonium Chloride Buffer:** Dissolve 67.5 g of ammonium chloride in about 200 ml of water, add 570 ml of strong ammonia solution and dilute with water to 1000 ml.

**Ammonia Buffer pH 9.5:** Dissolve 33.5 g of ammonium chloride in 150 ml of water, and 42 ml of 10 M ammonia and dilute with water to 250 ml.

Store in polyethylene containers.

**Ammonia Buffer pH 10.0:** Dissolve 5.4 g of *ammonium chloride* in 20 ml of *water*, add 35 ml of 10 M *ammonia* and dilute with *water* to 100 ml.

**Ammonia Buffer pH 10.9:** Dissolve 67.5 g of *ammonium chloride* in sufficient 10 M *ammonia* to produce 1000 ml.

**Barbitone Buffer pH 7.4:** Mix 50 ml of solution containing 1.944 per cent w/v of *sodium acetate* and 2.946 per cent w/v of *barbitone sodium* with 50.5 ml of 0.1 M *hydrochloric acid*, add 20 ml of an 8.5 per cent w/v solution of *sodium chloride* and dilute with *water* to 250 ml.

**Barbitone Buffer pH 8.6, Mixed; Barbitone Buffer pH 8.6:** Dissolve 1.38 g of *barbitone*, 8.76 g of *barbitone sodium* and 0.38 g of *calcium lactate* in sufficient *water* to produce 1000 ml.

**Boric Buffer pH 9.0; Borate Buffer pH 9.0:** Dissolve 6.20 g of *boric acid* in 500 ml of *water*, adjust to pH 9.0 with 1 M *sodium hydroxide* (about 41.5 ml) and dilute with *water* to 1000 ml.

**Buffer Solution pH 2.5:** To 25.0 ml of 0.2 M *potassium hydrogen phthalate* add 37.0 ml of 0.1 M *hydrochloric acid* and dilute with sufficient *water* to produce 100.0 ml.

**Buffer (HEPES) solution pH 7.5:** Dissolve 2.38 g of 2[4-(*hydroxyethyl*)piperazin-1-yl]ethanesulphonic acid in about 90 ml of *water*. Adjust the pH to 7.5 with *sodium hydroxide* solution. Dilute to 100 ml with *water*.

**Carbonate Buffer pH 9.7:** Dissolve 8.4 g of *sodium bicarbonate* and 10.6 g of *sodium carbonate* in sufficient *water* to produce 500 ml.

**Chloride Buffer pH 2.0:** Dissolve 6.57 g of *potassium chloride* in *water*, add 119.0 ml of 0.1 M *hydrochloric acid* and dilute with *water* to 1000 ml.

**Citro-phosphate Buffer pH 5.0:** Mix 48.5 ml of 0.1 M *citric acid* with sufficient 0.2 M *disodium hydrogen phosphate* to produce 100 ml.

**Citro-phosphate Buffer pH 6.0:** Mix 36.8 ml of a 2.1 per cent w/v solution of *citric acid* with 63.2 ml of a 7.15 per cent w/v solution of *disodium hydrogen phosphate*.

**Citro-phosphate Buffer pH 7.0:** Mix 17.6 ml of a 2.1 per cent w/v solution of *citric acid* with 82.4 ml of a 7.15 per cent w/v solution of *disodium hydrogen phosphate*.

**Citro-phosphate Buffer pH 7.2:** Mix 13.0 ml of a 2.1 per cent w/v solution of *citric acid* with 87.0 ml of a 7.15 per cent w/v solution of *disodium hydrogen phosphate*.

**Citro-phosphate Buffer pH 7.6:** Dissolve 1.33 g of *citric acid* and 67.1 g of *disodium hydrogen phosphate* in sufficient *water* to produce 1000 ml.

**Cupric Sulphate Solution pH 2.0, Buffered:** Mix 5.3 ml of 0.2 M *hydrochloric acid* and 25 ml of 0.2 M *potassium chloride*,

add 4 ml of a 0.393 per cent w/v solution of *cupric sulphate* and dilute to 100 ml of *water*.

**Cupric Sulphate Solution pH 4.0, Buffered:** Dissolve 0.25 g *cupric sulphate* and 4.5 g of *ammonium acetate* in sufficient *water* to produce 100 ml.

**Cupric Sulphate Solution pH 5.2, Buffered:** Dissolve 1.522 g of *anhydrous disodium hydrogen phosphate* in sufficient *water* to produce 53.6 ml and add a 2.1 per cent solution of *citric acid* until the pH of the solution is between 5.15 and 5.25 (about 46 ml). Mix 98.5 ml of the resulting solution with 1.5 ml of a 0.393 per cent solution of *cupric sulphate*.

**Diethanolamine Buffer pH 10.0:** Dissolve 96.4 g of *diethanolamine* in sufficient *water* to produce 400 ml. Add 0.5 ml of an 18.6 per cent w/v solution of *magnesium chloride*, adjust the pH to 10.0 with 1 M *hydrochloric acid* and dilute with *water* to 500 ml.

**Glycine Buffer pH 11.3:** Mix a solution containing 0.75 per cent w/v of *glycine* and 0.58 per cent w/v of *sodium chloride* with an equal volume of 0.1 M *sodium hydroxide*. Adjust the pH if necessary.

**Glycine Buffer Solution:** Mix 42 g of *sodium bicarbonate* and 50 g of *potassium bicarbonate* with 180 ml of *water* and add a solution containing 37.5 g of *glycine* and 15 ml of *strong ammonia* in 180 ml of *water*. Dilute with *water* to 500 ml and stir until solution is complete.

**Imidazole Buffer pH 6.5:** Dissolve 6.81 g of *imidazole* and 1.23 g of *magnesium sulphate* in 752 ml of 0.1 M *hydrochloric acid*, adjust the pH if necessary and dilute with *water* to produce 1000 ml.

**Imidazole Buffer pH 7.4:** Dissolve 3.40 g of *imidazole* and 5.84 g of *sodium chloride* in *water*, and 18.6 ml of 1 M *hydrochloric acid* and dilute with *water* to produce 1000 ml.

**Palladium Chloride Solution, Buffered:** To 0.5 g of *palladium chloride* add 5 ml of *hydrochloric acid* and warm on a water-bath. Add 200 ml of hot *water* in small portions with continued heating until solution is complete. Cool and dilute with sufficient *water* to produce 250.0 ml. To 50.0 ml of the resulting solution add 10.0 ml of 1 M *sodium acetate*, 9.6 ml of 1 M *hydrochloric acid* and sufficient *water* to produce 100.0 ml.

**Phosphate-albumin buffered saline pH 7.2:** Dissolve 10.75 g of *disodium hydrogen phosphate*, 7.6 g of *sodium chloride* and 10 g of *bovin albumin* in *water* and dilute to 1000.0 ml with the same solvent. Immediately before use adjust the pH (2.4.24) using *dilute sodium hydrogen solution* or *dilute phosphoric acid*.

**Phosphate Buffer pH 2.0:** Dissolve 0.136 g of *potassium dihydrogen phosphate* in 800 ml of *water*, adjust the pH to 2.0 with *hydrochloric acid* and add sufficient *water* to produce 1000 ml.

**Phosphate Buffer pH 2.5:** Dissolve 100 g of *potassium dihydrogen phosphate* in 800 ml of *water*, adjust the pH to 2.5 with *hydrochloric acid* and add sufficient *water* to produce 1000 ml.

**Phosphate Buffer pH 3.6:** Dissolve 0.900 g of *anhydrous disodium hydrogen phosphate* and 1.298 g of *citric acid monohydrate* in sufficient *water* to produce 1000 ml.

**Phosphate Buffer pH 4.0, Mixed:** Dissolve 5.04 g *disodium hydrogen phosphate* and 3.01 g of *potassium dihydrogen phosphate* in sufficient *water* to produce 1000 ml. Adjust the pH with *glacial acetic acid*.

**Phosphate Buffer pH 4.9:** Dissolve 40 g of *sodium dihydrogen phosphate* and 1.2 g of *sodium hydroxide* in sufficient *water* to produce 100 ml. If necessary, adjust the pH with 1 M *sulphuric acid* or 1 M *sodium hydroxide* as required.

**Phosphate Buffer pH 5.0:** Dissolve 6.8 g of *potassium dihydrogen phosphate* in 1000 ml of *water* and adjust the pH to 5.0 with 10 M *potassium hydroxide*.

#### **Phosphate Buffer pH 5.5, Mixed**

**SOLUTION I** — Dissolve 13.61 g of *potassium dihydrogen phosphate* in sufficient *water* to produce 1000 ml.

**SOLUTION II** — Dissolve 35.81 g of *disodium hydrogen phosphate* in sufficient *water* to produce 1000 ml.

Mix 96.4 ml of solution I with 3.6 ml of solution II.

**Phosphate Buffer pH 6.5:** Dissolve 60.5 g of *disodium hydrogen phosphate* and 46 g of *potassium dihydrogen phosphate* in *water*, add 100 ml of 0.02 M *disodium edetate* and 20 mg of *mercuric chloride* and dilute with *water* to produce 1000 ml.

**Phosphate Buffer pH 6.8, Mixed:** Dissolve 28.80 g of *disodium hydrogen phosphate* and 11.45 g of *potassium dihydrogen phosphate* in sufficient *water* to produce 1000 ml.

**Phosphate Buffer pH 6.8, 0.2 M Mixed:** Dissolve 13.872 g of *potassium dihydrogen phosphate* and 35.084 g of *disodium hydrogen phosphate* in sufficient *water* to produce 1000 ml.

Store in a cold place.

**Phosphate Buffer pH 7.0, Mixed:** Dissolve 0.50 g of *anhydrous disodium hydrogen phosphate* 0.301 g of *potassium dihydrogen phosphate* in sufficient *water* to produce 1000 ml.

**Phosphate Buffer pH 7.0 with Azide, Mixed:** To 1000 ml of a solution containing 1.8 per cent w/v of *disodium hydrogen phosphate* and 2.3 per cent w/v of *sodium chloride*, add sufficient of a solution containing 0.78 per cent w/v of *sodium dihydrogen phosphate* and 2.3 per cent w/v of *sodium chloride* (about 280 ml) to produce a pH of 7.0. Dissolve sufficient *sodium azide* in the resulting solution to give a 0.02 per cent w/v solution.

**Phosphate Buffer pH 7.0, 0.067 M Mixed:** Dissolve 3.532 g of *potassium dihydrogen phosphate* and 14.542 g of *disodium hydrogen phosphate* in sufficient *water* to produce 1000 ml.

#### **Phosphate Buffer pH 7.5, 0.33 M Mixed**

**SOLUTION I** — Dissolve 119.31 g of *disodium hydrogen phosphate* in sufficient *water* to produce 1000 ml.

**SOLUTION II** — Dissolve 45.36 g of *potassium dihydrogen phosphate* in sufficient *water* to produce 1000 ml.

Mix 85 ml of solution I and 15 ml of solution II and adjust the pH if necessary.

**Phosphate Buffer pH 8.0, 0.02 M:** Mix 50 ml of 0.2 M *potassium dihydrogen phosphate* with 46.8 ml of 0.2 M *sodium hydroxide* and add sufficient *water* to produce 500 ml.

**Phosphate Buffer, 0.025 M Standard:** Dissolve 3.40 g of *potassium dihydrogen phosphate* and 3.55 g of *anhydrous disodium hydrogen phosphate*, both previously dried at 110° to 130° for 2 hours, in sufficient *water* to produce 1000 ml.

**Saline, Phosphate-buffered:** Dissolve 2.5 g of *sodium dihydrogen phosphate*, 2.523 g of *disodium hydrogen phosphate* and 8.2 g of *sodium chloride* in sufficient *water* to produce 1000 ml.

**Saline pH 6.4, Phosphate-buffered:** Dissolve 1.79 g of *disodium hydrogen phosphate*, 1.36 g of *potassium dihydrogen phosphate* and 7.02 g of *sodium chloride* in sufficient *water* to produce 1000 ml.

**Saline pH 7.4, Phosphate-buffered:** Dissolve 2.38 g of *disodium hydrogen phosphate*, 0.19 g of *potassium dihydrogen phosphate* and 8.0 g of *sodium chloride* in sufficient *water* to produce 1000 ml. Adjust the pH if necessary.

**Tris-acetate buffer solution pH 8.5:** Dissolve 0.294 g of *calcium chloride* of *tris(hydroxymethyl)aminomethane* in *water*. Adjust the pH(2.4.24) with *acetic acid*. Dilute to 1000.0 ml with *water*.

**Tris(hydroxymethyl)aminomethane buffer solution pH 7.4:** Dissolve 30.3 g of *tris(hydroxymethyl)aminomethane* in approximately 200 ml of *water*. Add 183 ml of 1 M *hydrochloric acid*. Dilute to 500.0 ml with *water*.

**NOTE** — The pH is 7.7-7.8 at room temperature and 7.4 at 37°. This solution is stable for several months at 4°.

## **4.2 General Reagents**

**Acetaldehyde:** CH<sub>3</sub>CHO = 44.05

General laboratory reagent grade of commerce.

Clear, colourless, volatile liquid with an acrid, penetrating odour; bp, about 21°; wt. per ml, about 0.79 g.

Complies with the following test.



**ACIDITY** — To 10.0g, add sufficient *carbon dioxide-free water* to produce 50 ml and titrate with *0.1 M sodium hydroxide* using *phenolphthalein solution* as indicator; not more than 5.0 ml of *0.1 M sodium hydroxide* is required.

**N-Acetylneuraminic acid:**  $C_{11}H_{19}NO_9$  = Mol. Wt. 309.3

White acicular crystals, soluble in water and in methanol, slightly soluble in ethanol, practically insoluble in acetone.

$[\alpha]_D^{20}$ : about -36, determined on a 1 per cent w/v solution.; mp, about 186°, with decomposition.

**Acetic Acid:** Analytical reagent grade of commerce; contains approximately 33 per cent w/w of  $CH_3COOH$ . Dilute 315 ml of *glacial acetic acid* to 1000 ml with *water*.

**Acetic Acid, x M:** Solutions of any molarity x M may be prepared by diluting 57 x ml (60 x g) of *glacial acetic acid* to 1000 ml with *water*.

**Acetic Acid, Dilute:** Contains approximately 6 per cent w/w of  $CH_3COOH$ . Dilute 57 ml of *glacial acetic acid* to 1000 ml with *water*.

**Acetic Acid, Glacial:**  $CH_3COOH$  = 60.05

Analytical reagent grade of commerce.

Clear, colourless liquid; odour, pungent; about 17.5M in strength; congealing temperature, not lower than 14.8°; bp, about 118°; wt. per ml, about 1.047 g.

**Acetic Acid, Glacial, Anhydrous;** Anhydrous Acetic Acid:  $CH_3COOH$  = 60.05

Glacial acetic acid of commerce for use in non-aqueous titrations.

Complies with the following test.

**WATER** (2.3.43) — Not more than 0.4 per cent w/w. If the water content is greater than 0.4 per cent, it may be adjusted by adding the calculated amount of *acetic anhydride*.

**Acetic Acid Sp.:** *Acetic acid* which complies with the following test.

Make 25 ml alkaline with dilute *ammonia solution Sp.*, add 1 ml of *potassium cyanide solution Sp.*, dilute to 50 ml with *water* and add 2 drops of *sodium sulphide solution*; no darkening is produced.

**Acetic Acid Sp., Dilute:** *Dilute acetic acid* which complies with the following test.

Evaporate 20 ml in a porcelain dish nearly to dryness on a water-bath. Add to the residue 2 ml of the residue and dilute with *water* to 25 ml, add 10 ml of *hydrogen sulphide solution*; any dark colour produced is not more intense than that of a solution consisting of 2 ml of the acid and 4.0 ml of the *standard lead solution* diluted to 25 ml with *water*.

**Acetic Anhydride:**  $(CH_3CO)_2O$  = 102.09

Analytical reagent grade of commerce.

Clear, colourless liquid; odour, pungent; wt. per ml, about 1.08 g; distillation range, 136° to 142°.

**Acetic Anhydride-Dioxan Solution:** Add 1 ml of *acetic anhydride* to 50 ml of *dioxan*.

**Acetone;** 2-Propanone:  $(CH_3)_2CO$  = 58.08

Analytical reagent grade of commerce.

Clear, colourless, volatile liquid; odour, characteristic; flammable; bp, about 56°; wt. per ml, about 0.79 g.

**Acetone, Dry:** *Acetone* which contains not more than 0.3 per cent w/w of *water*, as determined by the following method.

**WATER** — Dilute about 12 ml of *acetyl chloride* to 100 ml with *toluene*. Transfer 10 ml to a dry, stoppered, 250-ml flask, preferably using a pipette with an automatic suction device, add 2 ml, accurately measured, of *pyridine*, immediately stopper tightly and shake vigorously avoiding wetting the stopper. Add 50 ml, accurately measured, of the reagent under examination and shake vigorously, avoiding wetting the stopper. Allow to stand for 5 minutes at room temperature, add by pipette 1.5 ml of *ethanol*, shake vigorously and allow to stand for 10 minutes. Add 25 ml of *ethanol* and titrate with *1 M sodium hydroxide* using *1-naphtholbenzein solution* as indicator. Add a slight excess of *1 M sodium hydroxide* and titrate with *1 M hydrochloric acid* after adding a few more drops of the indicator. Perform a blank determination. The difference between the two titrations represents the amount of sodium hydroxide equivalent to the *water* present. 1 ml of *1 M sodium hydroxide* is equivalent to 0.01802 g of  $H_2O$ .

**Acetonitrile:** Methyl Cyanide;  $CH_3CN$  = 41.05

General laboratory reagent grade of commerce.

Colourless liquid; bp, about 81°; wt. per ml, about 0.78 g.

*Acetonitrile intended for use in spectrophotometry complies with the following test.*

**TRANSMITTANCE** — Not less than 98 per cent in the range 255 to 420 nm using *water* as the blank.

**Acetyl Chloride:**  $CH_3COCl$  = 78.50

Analytical reagent grade of commerce.

Clear, colourless or very slightly yellow volatile liquid; smell, acrid or pungent; bp, about 51°; wt. per ml, about 1.1 g.

**Acid blue 83:**  $C_{45}H_{44}N_3NaO_7S_2$  = Mol. Wt. 826.0

Brown powder insoluble in cold water, slightly soluble in boiling water and in *ethanol*, soluble in sulphuric acid, glacial acetic acid and in dilute solution of alkali hydroxides.

**Acrylamide.**  $C_3H_5NO$  = Mol. Wt. 71.1

Colourless or white flakes or a white or almost white, crystalline powder, very soluble in water and in *methanol*, freely soluble in *ethanol*.

mp. about 84°.



**Acrylamide/bisacrylamide solution:** Prepare a solution containing 292 g of *acrylamide* and 8 g of *methylenebisacrylamide* per litre of *water*.

**Adrenaline Bitartrate:** Of the Indian Pharmacopoeia.

**Adrenaline Bitartrate, Noradrenaline-free;** Adrenaline Acid Tartrate, Noradrenaline-free: Adrenaline bitartrate which complies with the following additional test.

**NORADRENALINE** — Determine the paper chromatography (2.4.15).

*Mobile phase.* Using in the bottom of the tank the lower layer obtained by shaking together 4 volumes of *1-butanol*, 1 volume of *glacial acetic acid* and 5 volumes of *water* and allowing to separate and use the upper layer.

*Test solution.* A 0.5 per cent w/v solution of the reagent under examination.

Apply to the paper 20 µl of the reagent. Develop for 24 hours and spray the dried paper with a freshly prepared 0.44 per cent w/v solution of *potassium ferricyanide* in *alkaline borate buffer pH 8.0*; the paper shows only one spot, which is pink.

**Agar:** The dried extract from *Gelidium* sp. and other algae belonging to the class Rhodophyceae.

Microbiological reagent grade of commerce.

**β-Alanine:** 3-Aminopropionic Acid; C<sub>3</sub>H<sub>7</sub>NO<sub>2</sub> = 89.09

General laboratory reagent grade of commerce.

Orthorhombic bipyramidal crystals; mp, about 200°, with decomposition.

**Albumin, Bovine;** Bovine Serum Albumin: Bovine serum albumine (Cohn fraction V), containing about 9 per cent protein, that has been shown to be apyrogenic and also shown to be free from proteolytic activity by a suitable means, for example using *chromogenic substrate*.

White to light tan powder complying with the following test.

**WATER** (2.3.43) — Not more than 3.0 per cent w/w, determined on 0.8 g.

**Aluminium Potassium Sulphate;** Alum; Potash Alum; Aluminium Potassium Sulphate Dodecahydrate; AlK(SO<sub>4</sub>)<sub>2</sub>·12H<sub>2</sub>O = 474.40.

Analytical reagent grade of commerce.

**Alumina, Anhydrous;** Aluminium Oxide, Anhydrous: Al<sub>2</sub>O<sub>3</sub> = 101.96

Use a grade of commerce consisting of g-Al<sub>2</sub>O<sub>3</sub>, dehydrated and activated by heat treatment. The particle size is such that it passes through a 150 µm *sieve* but is retained on a 75 µm *sieve*.

**Alumina, Deactivated;** Aluminium Oxide, Deactivated: To a suitable basic alumina add 1.5 to 2 per cent of *water*, mix well

and allow to stand overnight in a stoppered bottle. The product complies with the following test.

Prepare a column (20 cm × 10 mm) using the alumina and *hexane*. Add a solution of 0.25 g of *ergocalciferol* in 10 ml of *hexane*. When the level of the solution falls just to the top of the column, begin eluting with a 17.5 per cent v/v solution of *ether* in *hexane* adjusting the rate of flow, if necessary, to between 1 and 2 ml per minute. Collect 200 ml of the eluate; no calciferol is present. Collect a further 100 ml of eluate, it contains not less than 95 per cent of the calciferol used in the test, when determined by the Assay described under Calciferol Oral Solution.

**Aluminium Chloride, Anhydrous:** AlCl<sub>3</sub> = 133.34

General laboratory reagent grade of commerce.

A white, grey or yellow, crystalline powder, or crystalline masses, fuming in air, with a strong odour of hydrochloric acid.

**Aluminium Chloride Solution:** Dissolve 35.9 g of *anhydrous aluminium chloride* in sufficient *water* to produce 100 ml, add 0.5 g, of *activated charcoal*, stir for 10 minutes, filter and add to the filtrate with continuous stirring sufficient of a 10 per cent w/v solution of *sodium hydroxide* to adjust the pH to about 1.5.

*CAUTION* — *Care should be taken in dissolving anhydrous aluminium chloride in water.*

**Aluminium Nitrate:** Al(NO<sub>3</sub>)<sub>3</sub>·9H<sub>2</sub>O = 375.13

Analytical reagent grade of commerce.

Deliquescent crystals.

**Aluminium Oxide G:** Fine, white, homogeneous powder, of an average particle size between 10µm and 40µm containing about 10 per cent w/w of calcium sulphate hemihydrate. Complies with the following tests.

**CALCIUM SULPHATE CONTENT** — Weigh accurately about 0.25 g, add 3 ml of 2 *M hydrochloric acid* and 100 ml of *water* and shake vigorously for 30 minutes. Filter and wash the residue with *water*. Titrate the combined filtrate and washings with 0.05 *M disodium edetate* to within a few ml of the expected end-point. Add 4 ml of 10 *M sodium hydroxide* and 0.1 g of *calcon mixture* and continue the titration until the colour changes from pink to full blue.

1 ml of 0.05 *M disodium edetate* is equivalent to 0.00726 g of CaSO<sub>4</sub>·½ H<sub>2</sub>O.

**pH** — About 7.5, determined in a suspension prepared by shaking 1 g with 10 ml of *carbon dioxide-free water*.

**Aluminium Sulphate:** Al<sub>2</sub>(SO<sub>4</sub>)<sub>3</sub>·16H<sub>2</sub>O = 630.38

Analytical reagent grade of commerce.

**4-Aminobenzoic Acid;** *p*-Aminobenzoic Acid: NH<sub>2</sub>C<sub>6</sub>H<sub>4</sub>COOH = 137.14

General laboratory reagent grade of commerce.

A white or off-white crystals; mp, about 188°.

Complies with the following test.

**HOMOGENITY** — Carry out the test for Related substances described under Procaine Hydrochloride; the chromatogram shows only one spot.

**N-(4-Aminobenzoyl)-L-glutamic Acid:**  $C_{12}H_{14}N_2O_5 = 266.26$

General laboratory reagent grade of commerce.

mp, about 173°.

**2-Amino-5-chlorobenzophenone:**  $C_{13}H_{10}ClNO = 231.68$

General laboratory reagent grade of commerce.

A yellow, crystalline powder; mp, about 99°.

Complies with the following test.

**HOMOGENEITY** — Carry out the test for Related substances described under Chlordiazepoxide Hydrochloride applying to the plate 5 $\mu$ l of a 0.05 per cent w/v solution in *methanol*; the chromatogram shows only one spot with an R<sub>f</sub> value of about 0.9.

Store protected from light.

**7-Aminodesacetoxycephasporanic Acid:**  $C_8H_{10}N_2O_3S = 214.20$

General laboratory reagent grade of commerce.

A light yellow powder.

**4-Amino-3-hydroxynaphthalene-1-sulphonic Acid;** Amino-2-naphthol-4-sulphonic Acid:  $C_{10}H_9NO_4S = 239.25$

General laboratory reagent grade of commerce.

A crystalline powder; mp, about 300°, with decomposition.

Store protected from light.

**Aminohydroxynaphthalenesulphonic Acid Solution:** Dissolve 0.25 g of *4-amino-3-hydroxynaphthalene-1-sulphonic acid* in about 75 ml of a 15 per cent w/v solution of *sodium metabisulphite*, warming to assist solution if necessary. Add 25 ml of a 20 per cent w/v solution of *sodium sulphite*, mix and add sufficient of the sodium metabisulphite solution to produce 100 ml.

**4-Aminophenazone;** Aminopyrazolone; 4-Amino- antipyrine; 4-Amino-2,3-dimethyl-1-phenyl-5- pyrazolone:  $C_{11}H_{13}N_3O = 203.24$

General laboratory reagent grade of commerce.

A yellow to buff powder; mp, about 109°.

**4-Aminophenazone Solution:** A 0.1 per cent w/v solution of *4-aminophenazone* in alkaline borate buffer pH 9.0.

**4-Aminophenol:** *p*-Aminophenol;  $NH_2C_6H_4OH = 109.13$

A white or almost white, crystalline powder; mp, about 186°.

**Ammonia, x M:** Solutions of any molarity x M may be prepared by diluting 75 x ml of *strong ammonia solution* to 1000 ml with *water*.

**Ammonia-Ammonium Chloride Solution, Strong:** Dissolve 67.5 g of *ammonium chloride* in 740 ml of *strong ammonia solution* and add sufficient *water* to produce 1000 ml.

**Ammonia-Cyanide Solution Sp.:** Dissolve 2 g of *potassium cyanide* in 15 ml of *strong ammonia solution* and dilute to 100 ml with *water*.

**Ammonia-Cyanide Wash Solution:** To 35 ml of wash solution pH 2.5 add 4 ml of *ammonia-cyanide solution Sp.* and mix.

**Ammonia, xM Ethanolic;** Ammoniacal Ethanol, x M: Solutions of any molarity x M may be prepared by diluting 75x ml of *strong ammonia solution* to 1000 ml with *methanol*.

**Ammonia, x M Methanolic;** Ammoniacal Methanol, x M: Solutions of any molarity x M may be prepared by diluting 75x ml of *strong ammonia solution* to 1000 ml with *methanol*

**Ammonia Solution, Dilute:** Contains approximately 10 per cent w/w of  $NH_3$ . Dilute 425 ml of *strong ammonia solution* to 1000 ml.

Store protected from moisture in a cool place.

**Ammonia, 18 M:** For 18M and 13.5 M ammonia use analytical reagent grade of commerce containing 35 per cent and 25 per cent w/v of ammonia and weighing 0.88 g and 0.91 g per ml, respectively. Solutions of any molarity x M may be prepared by diluting 75x ml of 13.5 M ammonia or 56x ml of 18 M ammonia to 1000 ml with *water*.

**Ammonia Solution Sp.:** *Strong ammonia solution* which complies with the following additional test.

Evaporate 10 ml to dryness on a water-bath. To the residue add 1 ml of *dilute hydrochloric acid Sp.* and evaporate to dryness. Dissolve the residue in 2 ml of dilute acetic acid Sp., add sufficient *water* to produce 25 ml and add 10 ml of *hydrogen sulphide solution*. Any darkening produced is not greater than that of a blank solution containing 2 ml of *dilute acetic acid Sp.*, 1.0 ml of *standard lead solution* and sufficient *water* to produce 25 ml.

**Ammonia Solution Sp., Dilute:** *Dilute ammonia solution* which complies with the following test.

To 20 ml add 1 ml of *potassium cyanide solution Sp.*, dilute to 50 ml with *water* and add 0.1 ml of *sodium sulphide solution*; no darkening is produced.

**Ammonia Solution, Iron-free:** *Dilute ammonia solution* which complies with the following test.

Evaporate 5 ml nearly to dryness on a water-bath, add 40 ml of *water*, 2 ml of 20 per cent w/v solution of *iron-free citric acid* and 0.1 ml of *thioglycollic acid*, mix, make alkaline with *iron-free ammonia solution*, and dilute to 50 ml with *water*; no pink colour is produced.

**Ammonia Solution, Strong:** Ammonia:  $\text{NH}_3 = 17.03$

Analytical reagent grade of commerce.

Contains 25.0 per cent w/w of  $\text{NH}_3$  (limits, 24.5 to 25.5); wt. per ml, about 0.91 g; strength, about 13.5M.

A clear, colourless liquid; odour, strongly pungent and characteristic.

Store protected from moisture in a cool place.

**Ammonium Acetate:**  $\text{CH}_3\text{COONH}_4 = 77.08$

Analytical reagent grade of commerce.

A colourless crystals or crystalline masses; odour, slightly acetous; very deliquescent.

**Ammonium Acetate, 0.1 M:** Dissolve 7.71 g of *ammonium acetate* in 200 ml of *water*, add 1 ml of *glacial acetic acid* and dilute to 1000 ml with *water*.

**Ammonium Acetate Solution:** Dissolve 150 g of *ammonium acetate* in 200 ml of *water*, add 3 ml of *glacial acetic acid* and dilute to 1000 ml with *water*.

Use a freshly prepared solution.

**Ammonium Carbonate:** A variable mixture of ammonium bicarbonate ( $\text{NH}_4\text{HCO}_3$ ) and ammonium carbamate ( $\text{NH}_2\text{COONH}_4$ ). Contains the equivalent of not less than 30.0 per cent w/w of  $\text{NH}_3$ .

Analytical reagent grade of commerce.

Store protected from moisture at a temperature not exceeding  $20^\circ$ .

**Ammonium Carbonate, 2 M:** Dissolve 156 g of *ammonium carbonate* in sufficient *water* to produce 1000 ml.

**Ammonium Carbonate Solution:** Dissolve 5 g of *ammonium carbonate* in a mixture of 7.5 ml of *dilute ammonia* and 50 ml of *water*, dilute to 100 ml with *water* and filter, if necessary.

**Ammonium Chloride:** Of the Indian Pharmacopoeia.

**Ammonium Chloride, 2 M:** Dissolve 106.98 g of *ammonium chloride* in sufficient *water* to produce 1000 ml.

**Ammonium Chloride-Ammonium Hydroxide Solution:** Mix 1 volume of *water* and 2 volumes of *strong ammonia solution* and saturate with *ammonium chloride*.

**Ammonium Chloride Solution:** A 10 per cent w/v solution of *ammonium chloride*.

**Ammonium Chloride Solution (Nessler's):** Dissolve 3.15 g of *ammonium chloride* in sufficient quantity of ammonia-free *water* to produce 1000 ml.

**Ammonium Chloride Solution, Dilute (Nessler's):** Mix 10 ml of *ammonium chloride solution (Nessler's)* with sufficient quantity of *ammonia-free water* to produce 1000 ml.

**Ammonium Citrate Solution:** Dissolve, with cooling, 500 g of *citric acid* in a mixture of 200 ml of *water* and 200 ml of *strong ammonia solution*, filter and dilute to 1000 ml with *water*.

**Ammonium Citrate Solution, Alkaline:** Dissolve 9 g of *citric acid* in about 150 ml of *water* and add gradually 50 ml of 5 *M ammonia*. Add 10 ml of *chloroform* and *dithizone solution* in 0.2-ml quantities until the *chloroform* layer, after vigorous shaking, is blue or purple. Discard the *chloroform* layer, add 10 ml of *chloroform* and 0.2 ml of *dithizone solution*, shake and allow to separate; the *chloroform* layer remains green. Discard the *chloroform* layer and wash the aqueous layer with successive quantities, each of 15 ml, of *chloroform* until the washings are colourless. Dilute the aqueous layer to 300 ml of with *water*.

**Ammonium Citrate Solution Sp.:** Dissolve 40 g of *citric acid* in 90 ml of *water*, add 2 drops of *phenol red solution* and then add slowly *strong ammonia solution* until the solution acquires a reddish colour. Remove any lead present by extracting the solution with successive quantities, each of 30 ml, of *dithizone extraction solution* until the dithizone solution retains its orange-green colour.

**Ammonium Dihydrogen Phosphate:** Ammonium Phosphate, Monobasic:  $\text{NH}_4\text{H}_2\text{PO}_4 = 115.03$

Analytical reagent grade of commerce.

Odourless crystals or crystalline powder.

**Ammonium Mercurithiocyanate Solution;** Mercuric Ammonium Thiocyanate Solution: Dissolve 30 g of *ammonium thiocyanate* and 27 g of *mercuric chloride* in sufficient *water* to produce 1000 ml.

**Ammonium Molybdate:**  $(\text{NH}_4)_6\text{Mo}_7\text{O}_{24}\cdot 4\text{H}_2\text{O} = 1235.86$   
Analytical reagent grade of commerce.

A white crystals or crystalline masses, sometimes with a yellowish or greenish tint.

**Ammonium Molybdate Solution:** A 10 per cent w/v solution of *ammonium molybdate*.

**Ammonium Molybdate Solution, Ethanolic**

**SOLUTION I** — Dissolve 5 g of *ammonium molybdate* in 20 ml of *water* with the aid of heat.

**SOLUTION II** — Mix 150 ml of *ethanol (95 per cent)* with 150 ml of *water* and add, with cooling, 100 ml of *sulphuric acid*.

Add 80 volumes of solution II to 20 volumes of solution I immediately before use.

**Ammonium Molybdate-Sulphuric Acid Solution:** Dissolve 10 g of *ammonium molybdate* in sufficient *water* to produce 100 ml and add the solution slowly to 250 ml of cold 10 *M sulphuric acid*.

Store in light-resistant plastic bottles.

**Ammonium Nitrate:**  $\text{NH}_4\text{NO}_3 = 80.04$

Analytical reagent grade of commerce.

**Ammonium Nitrate, 0.007 M:** Dissolve 0.5603 g of *ammonium nitrate* in sufficient *water* to produce 1000 ml.

**Ammonium Oxalate:**  $(\text{COONH}_4)_2 \cdot \text{H}_2\text{O} = 142.11$

Analytical reagent grade of commerce.

A colourless crystals.

**Ammonium Oxalate, 0.1 M:** Dissolve 14.21 g of *ammonium oxalate* in sufficient *water* to produce 1000 ml.

**Ammonium Oxalate Solution:** A 4.0 per cent w/v solution of *ammonium oxalate*.

**Ammonium Persulphate;** Ammonium Peroxodisulphate:  $(\text{NH}_4)_2\text{S}_2\text{O}_8 = 228.20$

Analytical reagent grade of commerce.

A white, granular crystals or crystalline powder.

**Ammonium Phosphate, Dibasic;** Ammonium Phosphate; Diammonium Hydrogen Phosphate; Diammonium Orthophosphate:  $(\text{NH}_4)_2\text{HPO}_4 = 132.06$

Analytical reagent grade of commerce.

A odourless crystals or crystalline powder; taste, saline and cooling; gradually loses about 8 per cent  $\text{NH}_3$ , more on exposure to air.

**Ammonium Phosphate, Dibasic, 0.2 M:** Dissolve 26.41 g of *dibasic ammonium phosphate* in sufficient *water* to produce 1000 ml.

**Ammonium Polysulphide Solution:** Dissolve a sufficient quantity of *precipitated sulphur* in *ammonium sulphide solution* to produce a deep orange solution.

**Ammonium Pyrrolidinedithiocarbamate;** Ammonium Tetramethylenedithiocarbamate:  $\text{C}_5\text{H}_{12}\text{N}_2\text{S}_2 = 164.28$

General Laboratory reagent grade of commerce.

Store in bottles containing a piece of *ammonium carbonate* in a muslin bag.

**Ammonium Pyrrolidinedithiocarbamate Solution:** A 1.0 per cent w/v solution of *ammonium pyrrolidinedithiocarbamate* that has been washed immediately before use with three quantities, each of 25 ml, of *4-methylpentan-2-one*.

**Ammonium Reineckate;** Ammonium Tetrathio-cyanatodiaminochromate(III) Monohydrate:  $\text{NH}_4[\text{Cr}(\text{NH}_3)_2(\text{CNS})_4] \cdot \text{H}_2\text{O} = 354.42$

General laboratory reagent grade of commerce.

A red powder or crystals.

**Ammonium Reineckate Solution:** A 1 per cent w/v solution of *ammonium reineckate*.

Use within 1 day of preparation.

**Ammonium Sulphamate:**  $\text{NH}_2\text{SO}_3\text{NH}_4 = 114.12$

General laboratory reagent grade of commerce.

A white, crystalline powder or colourless crystals; mp, about  $130^\circ$ .

**Ammonium Sulphate:**  $(\text{NH}_4)_2\text{SO}_4 = 132.13$

Analytical reagent grade of commerce.

A colourless crystals or white granules.

**Ammonium Sulphide Solution:** Saturate 120 ml of *6 M ammonia* with *hydrogen sulphide* and add 80 ml of *6 M ammonia*.

The solution should be freshly prepared.

**Ammonium Thiocyanate:**  $\text{NH}_4\text{SCN} = 76.12$

Analytical reagent grade of commerce.

A colourless crystals.

**Ammonium Thiocyanate, x M:** Solutions of any molarity x M may be prepared by dissolving 76.12x g in sufficient *water* to produce 1000 ml.

**Ammonium Thiocyanate Solution:** A 10 per cent w/v solution of *ammonium Thiocyanate*.

**Ammonium Thioglycollate Solution;** Ammonium Mercaptoacetate solution: Add 300 ml of *water* to 50 ml of *thioglycollic acid*, neutralise with about 40 ml of *strong ammonia solution* and dilute with *water* to produce 500 ml.

Store protected from moisture.

**Ammonium Vanadate;** Ammonium Metavanadate:  $\text{NH}_4\text{VO}_3 = 116.98$

Analytical reagent grade of commerce.

A white or slightly yellow, crystalline powder.

**Amyl Acetate:**  $\text{C}_7\text{H}_{14}\text{O}_2 = 130.19$

Consists principally of 3-methylbutyl acetate with a small proportion of 2-methylbutyl acetate.

Analytical reagent grade of commerce.

A colourless liquid with a sharp, fruity odour; bp, about  $140^\circ$ ; wt. per ml, about 0.87 g.

**Amyl Alcohol;** Isoamyl Alcohol:  $\text{C}_5\text{H}_{12}\text{O} = 88.15$

Consists principally of 3-methyl-1-butanol with a small proportion of 2-methyl-1-butanol.

Analytical reagent grade of commerce.

A colourless liquid; bp, about  $130^\circ$ ; wt. per ml, about 0.81 g.

**Aniline:**  $\text{C}_6\text{H}_5\text{NH}_2 = 93.13$

Analytical reagent grade of commerce

A colourless to pale yellow oily liquid; bp, about  $184^\circ$ ; wt. per ml, about 1.02 g.

Store protected from light.



**Anion Exchange Resin, Strongly Basic:** A gel-type resin in hydroxide form containing quaternary ammonium groups [ $\text{CH}_2\text{N}^+(\text{CH}_3)_3$ , type 1] attached to a polymer lattice consisting of polystyrene cross-linked with 8 per cent of divinylbenzene.

Brown, transparent beads containing about 50 per cent of water; particle size, 0.2 to 10 mm; total exchange capacity, at least 1.2 milliequivalents per ml.

**Anisaldehyde;** 4-Methoxybenzaldehyde:  $\text{CH}_3\text{OC}_6\text{H}_4\text{CHO} = 136.14$

General laboratory reagent grade of commerce.

A colourless to pale yellow, oily liquid; odour, aromatic; bp, about  $248^\circ$ ; wt. per ml, about 1.125 g.

*Anisaldehyde intended for use in gas chromatography complies with the following additional test.*

**ASSAY** — Determine the gas chromatography (2.4.13); the area of the principal peak is not less than 99.0 per cent of the total area of the peaks.

**Anisaldehyde Solution;** Anisaldehyde-Sulphuric Acid Reagent: Mix in the following order 0.5 ml of *anisaldehyde* 10 ml of *glacial acetic acid*, 85 ml of *methanol* and 5 ml of *sulphuric acid*.

**Anisaldehyde Solution, Ethanolic:** Mix in the following order 10 ml of *anisaldehyde*, 90 ml of *ethanol (95 per cent)* and 10 ml of *sulphuric acid*.

**Anthracene:**  $\text{C}_{14}\text{H}_{10} = 178.23$

General laboratory reagent grade of commerce.

A white, crystalline powder; mp, about  $218^\circ$ .

**Anthrone:**  $\text{C}_{14}\text{H}_{10}\text{O} = 194.23$

Analytical reagent grade of commerce.

A pale yellow, crystalline powder; mp, about  $155^\circ$ .

Complies with the following test.

**SENSITIVITY TO DEXTROSE** — Add carefully 6 ml of a 0.2 per cent w/v solution in a mixture of 19 ml of *sulphuric acid* and 1 ml of *water* to 3 ml of *water* containing 15 mg of *anhydrous dextrose*. Heat in a water-bath for 5 minutes taking precautions against loss of *water* by evaporation. The solution is darker green than a solution prepared in a similar manner but omitting the dextrose.

**Antimony Trichloride:**  $\text{SbCl}_3 = 228.11$

Analytical reagent grade of commerce.

A colourless crystals or flakes, fuming in moist air.

Store protected from light.

#### **Antimony Trichloride Reagent**

**SOLUTION I** — Dissolve 110 g of *antimony trichloride* in 400 ml of *1,2-dichloroethane*. Add 2 g of *anhydrous alumina*, mix

and filter through sintered glass into a 500-ml volumetric flask. Dilute to 500 ml with *1,2-dichloroethane* and mix. Absorbance of the resulting solution measured in a 2-cm cell at about 500 nm, not more than 0.07 using *1,2-dichloroethane* as the blank (2.4.7).

**SOLUTION II** — Mix 100 ml of colourless, distilled *acetyl chloride* and 400 ml of *1,2-dichloroethane* and store in a cool place.

Mix 90 ml of solution I and 10 ml of Solution II.

Store in amber glass-stoppered bottles and use within 7 days. Discard any reagent in which colour develops.

**Antimony Trichloride Solution:** To 100 ml of a 22.0 per cent w/v solution of *antimony trichloride* in *ethanol-free chloroform* add 2.5 ml of *acetyl chloride* and allow to stand for 24 hours before use.

**Aprotinin:** General Laboratory reagent grade of commerce containing 10 to 20 trypsin inhibitor units per mg.

**Arachidic Alcohol;** Eicosan-1-ol:  $\text{C}_{20}\text{H}_{42}\text{O} = 298.55$

Purified reagent grade of commerce usually containing not less than 95 per cent of  $\text{C}_{20}\text{H}_{42}\text{O}$ .

Colourless, waxy or crystalline solid.

**Arachis Oil:** Of the Indian Pharmacopoeia.

**Arsenic Trioxide:**  $\text{As}_2\text{O}_3 = 197.82$

Analytical reagent grade of commerce.

White or transparent, glassy amorphous lumps or crystalline powder.

**Ascorbic Acid:** Of the Indian Pharmacopoeia.

**Atropine Sulphate:** Of the Indian Pharmacopoeia.

**Barbaloin;** 1,8-Dihydroxy-3-hydroxymethyl-10-( $\beta$ -D-glucopyranosyl)anthrone:  $\text{C}_{21}\text{H}_{22}\text{O}_9, \text{H}_2\text{O} = 436.41$

General laboratory reagent grade of commerce.

Lemon Yellow to dark yellow needles or crystalline powder, darkening on exposure to air and light; mp, about  $148^\circ$ .

Complies with the following test.

**HOMOGENITY** — Determine by thin-layer chromatography (2.4.17), coating the plate with *silica gel G*.

*Mobile phase.* A mixture of 100 volumes of *ethyl acetate*, 17 volumes of *methanol* and 13 volumes of *water*.

*Test solution.* Dissolve 20 mg in 10 ml of *ethanol (70 per cent)*.

Apply to the plate 10  $\mu$ l of each solution. Allow the mobile phase to rise 10 cm. After development, dry the plate in air for 5 minutes and spray with a 5 per cent w/v solution of *potassium hydroxide* in *ethanol (50 per cent)*, heat at  $105^\circ$  for 15 minutes.

The principal spot in the chromatogram obtained shows only one major reddish brown spot due to barbaloin (Rf value, 0.4 to 0.5).

**Barbitone;** Barbital; 5,5-Diethylbarbituric Acid:

$C_8H_{12}N_2O_3 = 184.19$

General laboratory reagent grade of commerce.

Mp, about 190°.

**Barbitone Sodium:**  $C_8H_{11}N_2NaO_3 = 206.19$

General laboratory reagent grade of commerce.

A white crystalline powder.

**Barium Chloride:**  $BaCl_2 \cdot 2H_2O = 244.27$

Analytical reagent grade of commerce

Colourless crystals.

**Barium Chloride Solution:** A 10.0 per cent w/v solution of *barium chloride*.

**Barium Hydroxide:**  $Ba(OH)_2 \cdot 8H_2O = 315.47$

Analytical reagent grade of commerce

Transparent crystals or white masses; mp, about 78°.

**Barium Hydroxide, 0.1 M:** Dissolve 31.547 g of *barium hydroxide* in sufficient *water* to produce 1000 ml.

**Barium Hydroxide Solution:** A 3.0 per cent w/v solution of *barium hydroxide* in *water*.

**Barium Perchlorate:**  $Ba(ClO_4)_2 = 336.23$ .

General laboratory reagent grade of commerce.

White powder.

**Barium Sulphate:** Of the Indian Pharmacopoeia.

**Benzaldehyde:**  $C_7H_6O = 106.12$ .

Analytical reagent grade of commerce

Colourless to pale yellow, oily liquid with an odour of almonds, bp, about 178°; wt per ml, about 1.04 g.

Store protected from light.

**Benzalkonium Chloride Solution:** Of the Indian Pharmacopoeia.

**Benzene:**  $C_6H_6 = 78.11$

Analytical reagent grade of commerce

Colourless, transparent liquid; flammable; bp, about 80°; wt. per ml about 0.88 g.

**Benzethonium chloride;** Benzyl dimethyl-2-{2-[4-(1,1,3,3-tetramethylbutyl) phenoxy]ethylammonium Chloride Monohydrate:  $C_{27}H_{42}ClNO_2 \cdot H_2O = 466.12$

General Laboratory reagent grade of commerce.

Fine, white powder or colourless crystals; mp, about 163°

Store protected from light.

**Benzidine;** (1,1'-Biphenyl)-4,4'-diamine:  $C_{12}H_{12}N_2 = 184.23$

General Laboratory reagent grade of commerce.

Pale buff, crystalline powder; darkens on exposure to air and light; mp, about 128°(when anhydrous and rapidly heated).

Store protected from light and moisture.

Complies with the following tests.

**ORGANIC IMPURITIES** — Dissolve 0.1 g in 5 ml of *glacial acetic acid*; the solution is clear (2.4.1) and not more than faintly coloured; add 5 ml of a mixture of equal volumes of *hydrogen peroxide solution* and *water*; no darkening is produced.

**SENSITIVITY** — 2 ml of the solution from the test for **ORGANIC IMPURITIES**, add 1 ml of a freshly prepared 0.0001 per cent solution of blood in *water*; a blue or greenish blue colour is produced.

**Benzoic Acid:** Of the Indian Pharmacopoeia.

**Benzophenone:**  $C_{13}H_{10}O = 182.21$

General laboratory reagent grade of commerce.

mp, about 49°.

**Benzoyl Chloride:**  $C_6H_5COCl = 140.57$

Analytical reagent grade of commerce.

Colourless liquid with a pungent odour; fuming in moist air; bp, about 197°; wt. per ml, about 1.21 g.

**Benzyl Alcohol**

General laboratory reagent grade of commerce.

Colourless liquid; bp, about 204°; wt. per ml, about 1.05 g.

**Benzyl Benzoate:** Of the Indian Pharmacopoeia.

**Benzylpenicillin Sodium:** Of the Indian Pharmacopoeia.

**Bismuth Subnitrate:** Bismuth Oxynitrate; Bismuth Oxide Nitrate:  $BiNO_3 = 286.98$

General laboratory reagent grade of commerce

White, microcrystalline powder; a basic salt containing about 80 per cent of  $Bi_2O_3$ .

**Bis(trimethylsilyl)acetamide;** N,O-Bis(trimethylsilyl)-acetamide:  $CH_3CON[Si(CH_3)_3]_2 = 203.43$

General laboratory reagent grade of commerce.

Colourless liquid; bp, about 72°; wt. per ml, about 0.83 g.

**Biuret;** Carbonylurea:  $C_2H_5N_3O_2 = 103.09$

General laboratory reagent grade of commerce.

White, hygroscopic crystals; mp, 188° to 190°, with decomposition.

**Blue Tetrazolium**; Tetrazolium Blue; Blue Tetrazolium Salt; 3,3'-(3,3'-Dithioxy-4,4'-biphenylene)bis(2,5-diphenyl-2H-tetrazolium Chloride:  $C_{40}H_{32}Cl_2N_8O_2 = 727.65$

General laboratory reagent grade of commerce

Lemon Yellow crystals; mp, about 245°, with decomposition.

**Blue Tetrazolium Solution**: Dissolve 50 mg of blue tetrazolium in 10 ml of aldehyde-free *ethanol*.

**Blue Tetrazolium Solution, Alkaline**: Immediately before use mix 1 volume of a 0.2 per cent w/v solution of blue tetrazolium in *methanol* with 3 volumes of a 12 per cent w/v solution of sodium hydroxide in *methanol*.

**Borax**; Sodium Tetraborate; Disodium Tetraborate  $Na_2B_4O_7 \cdot 10H_2O = 381.37$

Analytical reagent grade of commerce.

Transparent, colourless crystals, or white, crystalline powder; odourless; taste, saline, and alkaline; effloresces in dry air; on ignition, loses all its *water* of crystallisation.

Store protected from moisture.

**Borax, 0.2 M**: Dissolve 76.28 g of borax in sufficient *water* to produce 1000 ml.

**Boric Acid**: Of the Indian Pharmacopoeia.

**Boric Acid Solution**: Dissolve 5 g of *boric acid* in a mixture of 20 ml of *water* and 20 ml of *ethanol* (95 per cent) and dilute to 250 ml with *ethanol* (95 per cent).

**Boron Trifluoride Solution**: Commercial grade containing about 14 per cent of  $BF_3$  in *methanol*.

#### **Bovin, albumin**

Bovin serum albumin containing about 96 per cent of protein.

A white to light-yellowish-brown power.

Complies with the following test.

**WATER** (2.3.43) — Maximum 3.0 per cent, determined on 0.800 g.

*Bovin albumin used in the assay of tetracosactide should be pyrogen-free, free from proteolytic activity, when examined by a suitable means, for example using chromogenic substrate, and free corticosteroid activity determined by measurement of fluorescences as described in the biological assay of Tetracosactide.*

**Bromine**:  $Br_2 = 159.80$

Analytical reagent grade of commerce.

Reddish brown, fuming, corrosive liquid; wt. per ml, about 3.12 g.

**Bromine, 0.0167 M**: Dissolve 1 g of *potassium bromate* and 5 g of *potassium bromide* in sufficient *water* to produce 1000 ml.

**Bromine Solution**: Dissolve 9.6 ml of *bromine* and 30 g of *potassium bromide* in sufficient *water* to produce 100 ml.

**Bromine Solution, Acetic**: Dissolve 100 g of *potassium acetate* in *glacial acetic acid* and add 4 ml of *bromine* and sufficient *glacial acetic acid* to produce 1000 ml.

**Bromine Water**: Freshly prepared saturated solution obtained by shaking occasionally during 24 hours 3 ml of *bromine* with 100 ml of *water* and allowing to separate.

Store the solution over an excess of *bromine* in light resistant containers.

**$\alpha$ -Bromo-2-acetonaphthone**; Bromomethyl 2-Naphthyl Ketone:  $C_{12}H_9BrO = 249.11$ .

Tannish pink crystals; mp, 81° to 83°.

**4-Bromoaniline**; *p*-Bromoaniline:  $C_6H_6BrN = 172.03$

General reagent grade of commerce.

White to off-white crystals; mp, about 62°.

**4-Bromoaniline Solution**: Dissolve 2 g of *4-Bromoaniline* in 100 ml of *glacial acetic acid* saturated with *thiourea*.

Store protected from light. Prepare fresh weekly.

**1-Butaneboronic Acid**:  $C_4H_{11}BO_2 = 101.93$

General Laboratory reagent grade of commerce.

Mp, about 95°.

**1,2-Butanediol**; 1-3-Butylene Glycol:  $C_4H_{10}O_2 = 90.12$ .

Viscous, colourless liquid; very hygroscopic; refractive index, between 1.4390 and 1.4410 at 20°.

Complies with the following additional test.

**ASSAY** — Determine by gas chromatography (2.4.13).

Chromatographic system

- a stainless steel column 1.8 m x 3 mm, packed with 20 per cent polyethylene glycol compound (average mol. wt. about 15,000) phase on support consisting of siliceous earth for gas chromatography, fluxcalcined by mixing diatomite with  $Na_2CO_3$  flux and calcining above 900°, which is acid-washed, then water-washed until neutral, but not base-washed (The siliceous earth may be silanised by treating with an agent such as dimethyldichlorosilane to mask surface silanol groups)
- temperature: Injection port temperature maintained at about 265°, column temperature at about 150° and programmed to rise 8° per minute to about 210
- flame ionisation detector
- carrier gas - helium

The area of the butanediol peak is not less than 98 per cent of the total peak area.

**1-Butanol**; Butan-1-ol; *n*-Butyl Alcohol:

$CH_3CH_2CH_2CHOHCH_3 = 74.12$

Analytical reagent grade of commerce.

Colourless liquid; bp, about 117°; wt. per ml, about 0.81 g.

**2-Butanol**; Butan-2-ol; *sec*-Butyl Alcohol:

$\text{CH}_3\text{CH}_2\text{CH}_2\text{CHOHCH}_3=74.12$

Colourless liquid; bp, about 99°; wt. per ml, about 0.81 g.

**2-Butanol Reagent**: *2-butanol* complying with the following tests.

**DISTILLATION RANGE** (2.4.8) — Not less than 95 per cent distils between 99° and 100°.

**ASSAY** — Not less than 99.0 per cent of  $\text{C}_4\text{H}_{10}\text{O}$  determined by the method for Benzene and related substances described in the monograph of Isopropyl Alcohol.

**2-Butanone**: Butan-2-one; Methyl Ethyl Ketone:

$\text{C}_2\text{H}_5\text{COCH}_3=72.11$

Chromatographic reagent grade of commerce.

Colourless, flammable liquid, odour, characteristic; bp, about 79°; wt. per ml, about 0.81 g.

**Butyl Acetate**:  $\text{CH}_3\text{COO}(\text{CH}_2)_3\text{CH}_3=116.16$

Analytical reagent grade of commerce.

Clear, colourless, flammable liquid with a strong, fruity colour, bp, about 126°; wt. per ml, about 0.88 g.

**Butylated Hydroxytoluene**: Of the Indian Pharmacopoeia.

***n*-Butyl Chloride**; 1-Chlorobutane:  $\text{CH}_3\text{CH}_2\text{CH}_2\text{CH}_2\text{Cl}=92.57$

General laboratory reagent grade of commerce.

bp, about 78°; refractive index at 20°, about 1.402; wt. per ml about 0.886 g.

**Butyric Acid**; *n*-Butyric Acid; Butanoic Acid:  $\text{C}_4\text{H}_8\text{O}_2=88.10$

General laboratory reagent grade of commerce.

Oily liquid; wt. per ml, about 0.96 g.

**Cadmium Iodide**:  $\text{CdI}_2=366.23$

Analytical reagent grade of commerce.

Pearly white flakes or a crystalline powder.

**Cadmium Iodide Solution**: A 5 per cent w/v solution of cadmium Iodide in *water*.

**Cadmium Sulphate**:  $3\text{CdSO}_4 \cdot 8\text{H}_2\text{O}=769.52$

Analytical reagent grade of commerce.

Monoclinic crystals; odourless.

**Calcium Acetate**:  $\text{Ca}(\text{C}_2\text{H}_3\text{O}_2)_2 \cdot \text{H}_2\text{O}=176.18$

White, crystalline granules or powder.

**Calcium Carbonate**: Of the Indian Pharmacopoeia.

**Calcium Chloride**: Of the Indian Pharmacopoeia.

**Calcium Chloride, xM**: Solutions of any molarity xM may be prepared by dissolving 147x g of *calcium chloride* in sufficient *water* to produce 1000 ml.

**Calcium Chloride, Anhydrous**:  $\text{CaCl}_2=110.99$

General laboratory reagent grade of commerce containing not less than 98.0 per cent w/w of  $\text{CaCl}_2$ , calculated with reference to the dried substance.

Dry white granules; very deliquescent.

Complies with the following test.

**LOSS ON DRYING** (2.4.19) — Not more than 5.0 per cent determined at 200°.

**Calcium Chloride Solution**: A 10.0 per cent w/v solution of *calcium chloride*.

**Calcium Gluconate**: Of the Indian Pharmacopoeia.

**Calcium Oxide**; Quicklime:  $\text{CaO}=56.08$

General laboratory reagent grade of commerce.

Dry, white lumps or powder; readily absorbs moisture and Carbon Dioxide from the atmosphere; when moistened with *water*, a reaction takes place with the evolution of heat and the lumps swell and fall to powder forming calcium hydroxide.

**Calcium Sulphate**; Calcium Sulphate Dihydrate;  $\text{CaSO}_4 \cdot 2\text{H}_2\text{O}=172.17$

Analytical reagent grade of commerce.

White Powder, loses only part of water at 100° to 150°.

**Calcium Sulphate Solution**: A saturated solution of *calcium sulphate*.

**Camphor**:  $\text{C}_{10}\text{H}_{16}\text{O}=152.24$

Natural camphor or produced synthetically.

Mp, between 174 and 179°;  $[\alpha]_D^{20}$ , 41° to 43° (natural, 10 per cent w/v in *ethanol*); synthetic, optically inactive.

***dl*-10-Camphoursulphonic Acid**:  $\text{C}_{10}\text{H}_{16}\text{O}_4=232.29$

White to off-white crystals or powder; optically inactive; mp, about 199°.

**Carbazole**; Dibenzylpyrrole:  $\text{C}_{12}\text{H}_9\text{N}=167.2$

Laboratory reagent grade of commerce.

mp, about 245°.

**Carbomer**; Carboxypolymethylene; Carbomer 934P: A synthetic high molecular weight polymer of acrylic acid cross linked with allylsucrose containing not less than 56.0 per cent and not more than 68.0 per cent of Carboxylic acid ( $-\text{COOH}$ ) groups, calculated with reference to the substance dried at 80° at a pressure not exceeding 2.5 kPa for 1 hour.

White, fluffy powder; odour, slight and characteristic; hygroscopic.



Complies with the following tests.

**ACIDITY** — A 1 per cent w/v dispersion produces an orange colour with *thymol blue solution* and a yellow colour with *cresol red solution* (pH about 3).

**VISCOSITY** — Between 29400 and 39400 centipoises when determined by the following method.

Fix a stirrer capable of running at a speed of  $1000 \pm 10$  rpm in a 1000-ml beaker containing 500 ml of *water* so that the shaft is at an angle of  $60^\circ$  and to one side of the beaker and the propeller is near the bottom of the beaker. While stirring continuously, add 2.5 g carefully and with uniform rate over a period of 45 to 90 seconds, ensuring that loose aggregates of powder are broken up, and continue stirring at  $1000 \pm 10$  rpm for 15 minutes. Remove the stirrer and place the beaker with its contents in a water-bath at  $25^\circ \pm 0.2^\circ$  for 30 minutes. Insert the stirrer to a depth necessary to ensure that air is not drawn into the dispersion and continue stirring at  $300 \pm 10$  rpm. Titrate with a calomel-glass electrode system to a pH of  $7.5 \pm 0.3$  by adding an 18 per cent w/v solution of *sodium hydroxide* below the surface, the end-point being determined potentiometrically (Approximately 6.2 ml of the *sodium hydroxide solution* will be required). Allow 2 to 3 minutes before final determination of pH. If the final pH exceeds 7.8, discard the mucilage and redetermine the pH by using lesser quantity of the *sodium hydroxide solution* for titration. Place this mucilage in the water-bath at  $25^\circ$  for 1 hour, and determine its viscosity by method C (2.4.28), without delay to avoid slight viscosity changes possible after 75 minutes of alkali addition. Equip a suitable rotating viscometer with a spindle having a cylinder of 1.47 cm diameter and 0.16 cm height attached to a shaft of 0.32 cm diameter, the distance from that of the cylinder to the lower tip of the shaft being 3.02 cm, and the immersion depth being 4.92 cm (No.6 spindle). Rotate the spindle at 20 rpm and record the scale reading on the viscometer. Calculate the viscosity in centipoises by multiplying the scale reading with spindle constant at 20 rpm.

Store protected from moisture.

**Carbon Dioxide:**  $\text{CO}_2 = 44.01$

Cylinder of general laboratory grade of commerce.

Colourless, noncombustible gas; odourless.

**Carbon Disulphide:**  $\text{CS}_2 = 76.14$

Analytical reagent grade of commerce.

Colourless, volatile flammable liquid with an unpleasant odour bp, about  $46^\circ$ ; wt. per ml, about 1.26 g.

**Carbon Tetrachloride;** Tetrachloromethane:  $\text{CCl}_4 = 153.82$

Analytical reagent grade of commerce.

Clear, colourless, volatile liquid; odour, characteristic; bp, about  $76^\circ$ ; wt. per ml, about 1.59 g.

**Carboxymethylcellulose;** CMC: A monofunctional, weakly acidic, cation-exchange substance in a fibrous form. Stir 1 part into 15 parts of  $0.5\text{ M}$  *sodium hydroxide* and allow to stand for at least 30 minutes. Remove the supernatant liquid and wash the residue with *water* until the washings have a pH of 8. Stir the residue with 15 parts of  $0.5\text{ M}$  *hydrochloric acid* and allow to stand for 15 minutes. Repeat the acid treatment and finally wash with *water* until the washings are almost neutral. Suspend the residue in *water* containing 1 per cent v/v of *benzyl alcohol* and store until required.

**Casein:** Mixture of related phosphoproteins obtained from milk.

General laboratory reagent grade of commerce.

White, amorphous powder or granules.

**Casein Hydrolysate:** A pancreatic digest of *casein* of general laboratory or microbiological grade of commerce.

**Casein, Purified:** White or slightly yellow, granular powder; odourless.

Casein, according Hammersten, which is commercially available may be used.

**Casein Solution:** Weigh accurately 4 g of *purified casein*, dissolve by shaking with 90 ml of *water*, adjust the pH to 7.0 and dilute with sufficient *water* to produce 100 ml.

**Catechol;** Pyrocatechol; Benzene-1,2-diol; *o*-Dihydroxybenzene:  $\text{C}_6\text{H}_4(\text{OH})_2 = 110.11$

General laboratory reagent grade of commerce.

White crystalline powder; mp about  $103^\circ$ .

Store protected from light.

**Catechol Solution:** A freshly prepared 10 per cent w/v solution of *catechol*.

**Cellulose, Microcrystalline:** Of the Indian Pharmacopoeia.

**Ceric Ammonium Nitrate;** Ammonium Ceric Nitrate; Ammonium Cerium (IV) Nitrate:  $[\text{Ce}(\text{NO}_3)_4 \cdot 2\text{NH}_4\text{NO}_3] = 548.23$

Analytical reagent grade of commerce.

**Ceric Ammonium Sulphate;** Ammonium Ceric Sulphate; Ammonium Cerium (IV) Sulphate:  $\text{Ce}(\text{SO}_4)_2 \cdot 2(\text{NH}_4)_2\text{SO}_4 \cdot 2\text{H}_2\text{O} = 632.53$

Analytical reagent grade of commerce.

Yellow or yellowish orange crystals or a crystalline powder.

**Cerous Nitrate;** Cerium (III) Nitrate:  $\text{Ce}(\text{NO}_3)_3 \cdot 6\text{H}_2\text{O} = 434.23$ .

General laboratory reagent grade of commerce.

Colourless or pale yellow, moist crystalline powder.

**Cerous Nitrate Solution:** Dissolve 0.22 g of *cerous nitrate* in 50 ml of *water*, add 0.1 ml of *nitric acid* and 50 mg of

*hydroxylamine hydrochloride*, and dilute to 1000 ml with *water*.

**Cetrimide:** Of the Indian Pharmacopoeia.

**Cetyl Palmitate;** Hexadecyl Hexadecanoate; Hexadecyl Palmitate:  $C_{32}H_{64}O_2 = 480.86$ .

General chromatographic grade of commerce.

**Charcoal, Activated:** Of the Indian Pharmacopoeia.

**Charcoal, Decolorising:** Activated Charcoal of the Indian Pharmacopoeia which complies with the following additional test.

**DECOLORISING POWDER** — Add 0.1 g to 50 ml of a 0.006 per cent w/v solution of *bromophenol blue* in *ethanol (20 per cent)* contained in a 250 ml flask, mix by rotating the vessel, allow to stand for 5 minutes and filter; the colour of the filtrate is not more intense than that of a solution prepared by diluting 1 ml of the *bromophenol blue solution* to 50 ml with *ethanol (20 per cent)*.

**Chloral Hydrate:**  $C_2H_3Cl_3O_2 = 165.40$

General laboratory reagent grade of commerce.

Colourless, hygroscopic crystals with a sharp odour; mp, about 55°.

Complies with the following tests.

**APPEARANCE OF SOLUTION** — A 10.0 per cent w/v solution is clear (2.4.1) and colourless (2.4.1)

**RESIDUE ON EVAPORATION** — Not more than 0.2 per cent w/w, determined by evaporating 2 g to dryness on a water-bath.

**Chloral Hydrate Solution:** Dissolve 80 g of a *chloral hydrate* in 20 ml of *water*.

**Chloramine T;** Chloramine; Sodium salt of N-chlorotoulene-p-sulphonamide:  $C_7H_7ClNNaO_2S_3H_2O = 281.72$

General laboratory reagent grade of commerce.

White crystals or white, crystalline powder; odour, that of chlorine; efflorescent; decomposed slowly by *ethanol*.

**Chloramine T Solution;** Chloramine Solution: A 2.0 per cent w/v solution of chloramine T.

Prepare immediately before use.

**Chlorinated Lime;** Bleaching Powder: Contains not less than 30 per cent w/w of available chlorine. Dry, dull-white powder; odour, characteristic; on exposure to air it becomes moist and gradually decomposes.

Store protected from moisture.

**Chlorinated Lime Solution:** Mix 100 g of chlorinated lime with 1000 ml of *water* in a stoppered bottle, set aside for 3 hours shaking occasionally and filter through calico.

The solution must be freshly prepared.

**Chlorine:** Greenish Yellow diatomic gas; odour, suffocating.

**Chlorine Solution:** A freshly prepared, saturated solution of chlorine in *water*.

**4'-Chloroacetanilide:**  $CH_3CONHC_6H_4Cl = 169.61$

General laboratory reagent grade of commerce.

Colourless, rhombic crystals or plates; mp, about 178°.

**4'-Chloroaniline;** *p*-Chloroaniline:  $ClC_6H_4.NH_2 = 127.57$

General laboratory reagent grade of commerce.

White or faintly coloured crystals; mp about 71°.

**4-Chlorobenzenesulphonamide:**  $C_6H_6ClNO_2S = 191.63$

General laboratory reagent grade of commerce.

mp, about 145°.

**4-Chlorobenzoic Acid:**  $C_7H_5ClO_2 = 156.57$

General laboratory reagent grade of commerce.

Triclinic crystals; mp, about 240°.

**4-Chloro-*o*-cresol;** 4-Chloro-2-methylphenol:  $C_7H_7ClO = 142.56$

General laboratory reagent grade of commerce.

mp, about 144°.

**1-Chloro-2,4-dinitrobenzene:**  $ClC_6H_3(NO_2)_2 = 202.56$

Analytical reagent grade of commerce.

Pale Yellow crystals or crystalline powder; mp, about 51°.

**Chloroform:** Of the Indian Pharmacopoeia.

**Chloroform, Ethanol-free:** Wash repeatedly *chloroform* with *water*, dry with *anhydrous sodium sulphate* and distil; wt.per ml, about 1.489 g.

Ethanol-free chloroform must be freshly prepared.

**CAUTION** — Ethanol free chloroform is poisonous.

**Chloroform IR:** Spectroscopic reagent grade of commerce.

**Chloroform, prepared:** Distill *chloroform* in hard or borosilicate glass apparatus and collect the distillate in sufficient *ethanol* to make the final concentration of ethanol as 1 per cent v/v.

**Chloroform Water:** Shake 2.5 ml of *chloroform* with 900 ml of *water* until dissolved and dilute to 1000 ml with *water*.

**5-Chloro-8-hydroxyquinoline;** 5-Chloroquinolin-8-ol:  $C_9H_6ClNO = 179.60$

General laboratory reagent grade of commerce.

mp, about 123°.

**2-Chloro-4-nitroaniline:**  $C_6H_5ClN_2O_2 = 172.57$

General laboratory reagent grade of commerce.

Yellow to brown, crystalline powder; mp, about 107°.

Store protected from light.

**Chloroplatinic Acid**; Platinic Chloride:  $\text{H}_2\text{PtCl}_6 \cdot 6\text{H}_2\text{O} = 517.91$  or  $\text{H}_2\text{PtCl}_6 \cdot 3\text{H}_2\text{O} = 463.82$

General laboratory reagent grade of commerce.

Brownish, deliquescent, crystalline masses; contains not less than 37 per cent w/v of Pt.

**ASSAY** — Ignite 0.2 g to constant weight at 900° and weigh the residue (Platinum)

Store protected from light.

**Chloroplatinic Acid Solution**; Platinic Chloride Solution: A solution of *chloroplatinic acid* in *water* containing the equivalent of 5 per cent w/v of  $\text{H}_2\text{PtCl}_6 \cdot 6\text{H}_2\text{O}$ .

**5-Chlorosalicylic Acid**:  $\text{C}_7\text{H}_5\text{ClO}_3 = 172.57$

General laboratory reagent grade of commerce.

**Choline Chloride**; (2-Hydroxyethyl)trimethyl-ammonium Chloride:  $\text{C}_5\text{H}_{14}\text{ClNO} = 139.63$

General laboratory reagent grade of commerce.

Deliquescent crystals.

Complies with the following test.

**HOMOGENEITY** — Determine by thin-layer chromatography (2.4.17), coating the plate with microcrystalline cellulose.

*Mobile phase.* the upper layer obtained by shaking together for 10 minutes and then allowing to separate a mixture of 50 volumes of *1-butanol*, 40 volumes of *water* and 10 volumes of *anhydrous formic acid*.

Apply to the plate 5 ml of a 0.02 per cent w/v solution in *methanol*. The chromatogram obtained after drying the plate and spraying with *potassium iodobismuthate solution* shows only one spot.

Store protected from moisture.

**Chromic Acid Solution**: Dissolve 84 g of *chromium trioxide* in 700 ml of *water* and add slowly, with stirring, 400 ml of *sulphuric acid*.

**Chromic-Sulphuric Acid**; Chromic-Sulphuric Acid Mixture: A saturated solution of *chromium trioxide* in *sulphuric acid*.

**Chromium Trioxide**:  $\text{CrO}_3 = 99.99$

Analytical reagent grade of commerce.

Dark red, deliquescent crystals or flakes or granular powder.

Store in a well-closed, glass, stoppered containers.

**Chromogenic Substrate**: *N*-Benzoyl-L phenylalanyl-L-valyl-L-arginine 4-nitroanilide Hydrochloride:  $\text{C}_{33}\text{H}_{40}\text{N}_8\text{O}_6 \cdot \text{HCl} = 681.19$

General laboratory reagent grade of commerce.

**Chromotropic Acid**; 4,5-Dihydroxynaphthalene-2,7-disulphonic Acid:  $\text{C}_{10}\text{H}_8\text{O}_8\text{S}_2 \cdot 2\text{H}_2\text{O} = 356.31$

General laboratory reagent grade of commerce.

White to brownish powder or white needles.

**Chromotropic Acid Sodium Salt**; Disodium 4,5-dihydroxynaphthalene-2,7-disulphonate:  $\text{C}_{10}\text{H}_6\text{Na}_2\text{O}_8\text{S}_2 \cdot 2\text{H}_2\text{O} = 400.30$

General laboratory reagent grade of commerce.

Pale brown powder or white needles or leaflets.

Complies with the following additional test.

**SENSITIVITY TO FORMALDEHYDE** — Dissolve 5 mg of *chromotropic acid* or *chromotropic acid sodium salt* in 10 ml of a mixture of 9 ml of *sulphuric acid* and 4 ml of *water*. Dilute exactly 0.5 ml of *formaldehyde solution* with *water* to make 1000 ml. Add 5 ml of this solution to the solution of chromotropic acid or of its Sodium salt and heat in a *water-bath* for 30 minutes; a violet colour is produced. Use a solution prepared in the same manner using *water* in place of the formaldehyde solution for comparison.

**Chromotropic Acid Solution**: Dissolve 50 mg of *chromotropic acid* or *chromotropic acid sodium salt* in 100 ml of a mixture of 9 ml of *sulphuric acid* and 4 ml of *water*.

**Cineole**; Eucalyptol; 1,8-Epoxy-p-menthane:  $\text{C}_{10}\text{H}_{18}\text{O} = 154.25$

A grade of commerce specially supplied for o-cresol determinations.

Colourless liquid with a camphoraceous odour; bp, about 176°; refractive index at 20°, about 1.457; wt. per ml, about 0.92 g.

**Cinnamaldehyde**; Cinnamic Aldehyde:  $\text{C}_9\text{H}_8\text{O} = 132.15$

General laboratory reagent grade of commerce.

Pale-yellow, oily liquid; wt. per ml, about 1.05 g.

Store protected from light in a cool place.

**Citrate-Cyanide Wash Solution**: To 50 ml of *water* add 50 ml of *ammonium citrate solution Sp.* and 4 ml of *potassium cyanide solutions Sp.*, mix and adjust the pH to 9.0, if necessary, with *strong ammonia solution*.

**Citric Acid**: Of the Indian Pharmacopoeia.

**Citric Acid, 0.1 M**: Dissolve 21.0 g of *citric acid* in sufficient *water* to produce 1000 ml.

**Citric Acid, Anhydrous**: Of the Indian Pharmacopoeia.

**Citric Acid, Iron-Free**: *Citric Acid* which complies with the following additional test.

Dissolve 0.5 g in 40 ml of *water*, add 2 drops of *thioglycollic acid*, mix, make alkaline with *iron-free ammonia solution*, and dilute to 50 ml with *water*; no pink colour is produced.

**Citric- Molybdc Acid Solution:** Mix 54 g of *molybdc oxide* with 200 ml of *water*, add 11 g of *sodium hydroxide* and heat, with stirring, until almost complete solution has been obtained. Dissolve 60 g of *citric acid* in 250 ml of *water* and add 140 ml of *hydrochloric acid*. Add the first solution to the second, stirring continuously, cool, filter if necessary, dilute to 1000 ml with *water* and add, dropwise, sufficient of a 1 per cent w/v solution of *potassium bromate* to discharge the green colour.

Store protected from light and moisture.

**Clotting Factor V Solution:** Clotting Factor V Solution may be prepared by the following method or by any other method that excludes factor VIII.

Prepare from fresh oxalated bovine plasma by fractionation at 4° with a saturated solution of *ammonium sulphate* prepared at 4°. Use the fraction precipitating between 38 and 50 per cent saturation (which contains clotting factor V not significantly contaminated with clotting factor VIII), dialysed to remove ammonium sulphate and diluted with *saline solution* to produce a solution containing between 10 to 20 per cent of the amount of clotting factor V present in fresh norman human plasma.

Determine the clotting factor V content of the solution in the following manner. Prepare two dilutions in *imidazole buffer pH 7.4* to contain 1 volume to the solution under examination in 10 volumes and 20 volumes, respectively. Test each dilution as follows:

Mix 0.1 ml of each of *substrate plasma deficient in clotting factor V*, the dilution being tested, *thrombokinas extract* and 0.025 M *calcium chloride*. Record as the clotting time the interval between the addition of the *calcium chloride* solution and the first indication of fibrin formation, which may be observed visually or by mechanical means.

Similarly determine the clotting times, in duplicate, for four dilutions of pooled norman human plasma in *imidazole buffer pH 7.4* containing 1 volume in 10 volumes (equivalent to 100 per cent of clotting factor V), in 50 volumes (20 per cent), in 100 volumes (10 per cent) and in 1000 volumes (1 per cent), respectively.

To calculate the result, plot the mean of the clotting times for each dilution of human plasma on double cycle log/log paper against the equivalent percentage for clotting actor V and read the percentage of clotting factor V for the two dilutions of *clotting factor V solution* by interpolation from the curve. The mean of the two results is taken as the percentage of clotting factor V in the solution.

**Cobalt Acetate;** Cobaltous Acetate; Cobalt (II) Acetate:  $(\text{CH}_3\text{COO})_2\text{Co}\cdot 4\text{H}_2\text{O} = 249.08$

General laboratory reagent grade of commerce.

Deep red crystals; odour, faintly acetous.

**Cobalt Chloride;** Cobaltous Chloride; Cobalt (II) Chloride:  $\text{CoCl}_2\cdot 6\text{H}_2\text{O} = 237.93$

Analytical reagent grade of commerce.

Deep red crystals, slightly deliquescent.

**Cobalt Chloride Solution:** Dissolve 6.5 g of *cobalt chloride* in 8 ml of 2 M *hydrochloric acid* and dilute to 100 ml with *water*.

**Cobalt Nitrate;** Cobaltous Nitrate; Cobalt (II) Nitrate:  $\text{Co}(\text{NO}_3)_2\cdot 6\text{H}_2\text{O} = 291.03$

Analytical reagent grade of commerce.

Red Crystals; deliquescent.

**Cobalt Thiocyanate Solution:** Dissolve 6.8 g of *cobalt chloride* and 4.3 g of *ammonium thiocyanate* in sufficient *water* to produce 100 ml.

**Codeine;** (5R,6S)-4,5-Epoxy-3-methoxy-N-methyl-morphin-7-en-6-ol monohydrate:  $\text{C}_{18}\text{H}_{21}\text{NO}_3\cdot \text{H}_2\text{O} = 317.37$

Colourless crystals or white, crystalline powder; odourless; mp, about 157°;  $[\alpha]_D^{20}$ , about -142° to -146° [2 per cent w/v in *ethanol (95 per cent)*]; contains not less than 99.0 per cent and not more than 101.0 per cent of  $\text{C}_{18}\text{H}_{21}\text{NO}_3$ , calculated with reference to the dried substance.

Store protected from light and moisture.

**Codeine Phosphate:** Of the Indian Pharmacopoeia.

**Colchicine:** Of the Indian Pharmacopoeia.

**Coomassie staining solution.** A 1.25 g per litre solution of *acid blue 83* in a mixture consisting of 1 volume of *glacial acetic acid*, 4 volume of *methanol* and 5 volume of *water*.

**Copper;** Copper Foil; Copper Turnings:  $\text{Cu} = 63.55$

Pure metal known commercially under the term 'electrolytic'.

Usually in the form of foil, turnings or borings.

**Copper Solution, Alkaline**

**Solution I** — Dissolve 8 g of *sodium hydroxide* in 200 ml of *distilled water*, add 40 g of *sodium carbonate* and make up the volume to 1000 ml with *water*.

**Solution II** — Dissolve 4 g of *potassium tartrate* and 2 g of *cupric sulphate* in sufficient *water* to produce 100 ml.

Mix 50 ml of solution I and 1 ml of solution II just before use.

**Cresol:** Of the Indian Pharmacopoeia.

**Cupric Acetate;** Copper (II) Acetate:  $(\text{CH}_3\text{COO})_2\text{Cu}\cdot \text{H}_2\text{O} = 199.65$

Analytical reagent grade of commerce.

Dark green crystals.

**Cupric Chloride;** Copper (II) Chloride:  $\text{CuCl}_2\cdot 2\text{H}_2\text{O} = 170.48$

Analytical reagent grade of commerce.



Green to blue powder or crystals, deliquescent in moist air, efflorescent in dry air.

**Cupric Chloride-Pyridine Reagent;** Copper Chloride-Pyridine Reagent: Dissolve 40 mg of *cupric chloride* in *pyridine*, warming until complete dissolution is effected, and cool. Add 1 ml of *carbon disulphide* and sufficient *pyridine* to produce 100 ml.

**Cupri-Citric Solution;** Copper-Citric Solution; Sodium Cupri-Citrate Solution: Dissolve 25 g of *cupric sulphate*, 50 g of *citric acid* and 144 g of *anhydrous sodium carbonate* in sufficient *water* to produce 1000 ml.

**Cupric Sulphate;** Copper(II) Sulphate:  $\text{CuSO}_4 \cdot 5\text{H}_2\text{O} = 249.68$   
Analytical reagent grade of commerce.

Large, blue or ultramarine crystals or blue granules or light blue powder, slowly efflorescent in air.

**Cupric Sulphate 0.02 M:** Dissolve 5.0 g of *cupric sulphate* in *water* and dilute to 1000 ml with *water*.

**Cupric Sulphate Solution;** Copper Sulphate Solution: A 12.5 per cent w/v solution of *cupric sulphate*.

**Cupric Sulphate Solution, Weak;** Cupric Sulphate Solution, Dilute: A 10.0 per cent w/v solution of *cupric sulphate*.

**Cupric Sulphate with Pyridine Solution:** Dissolve 4 g of *cupric sulphate* in 90 ml of *water* and add 30 ml of *pyridine*. The solution should be freshly prepared.

**Cupri-Tartaric Solution;** Modified Potassium Cupritartrate Solution.

**SOLUTION I** — Dissolve 34.6 g of *cupric sulphate* in sufficient *water* to produce 500 ml.

**SOLUTION II** — Dissolve 173 g of *sodium potassium tartrate* and 50 g of *sodium hydroxide* in 400 ml of *water*, heat to boiling, allow to cool and dilute to 500 ml with freshly boiled and cooled *water*.

Mix equal volumes of solution I and II immediately before use.

**Cuprous Chloride;** Copper (I) Chloride:  $\text{CuCl} = 99.00$   
Analytical reagent grade of commerce.

**Curcumin;** 1,7-Bis(4-hydroxy-3-methoxyphenyl)-hepta-1,6-dien-3,5-dione:  $\text{C}_{21}\text{H}_{20}\text{O}_6 = 368.39$

General laboratory reagent grade of commerce.

Orange brown, crystalline powder; mp, about 183°.

**Cyanogen Bromide Solution:** Add, drop-wise with cooling, 0.1 M ammonium thiocyanate to bromine water until the colour disappears.

Prepare immediately before use.

**Cyclohexane:**  $\text{C}_6\text{H}_{12} = 84.16$

Analytical reagent grade of commerce.

Clear, colourless liquid: bp, about 81°; wt. per ml, about 0.78 g.  
*Cyclohexane intended for use in spectrophotometry complies with the following test.*

**TRANSMITTANCE** — Not less than 45 per cent at about 220 nm, 80 per cent at about 235 nm, 90 per cent at about 240 nm and 98 per cent at about 250 nm, using *water* as the blank.

*Cyclohexane intended for use in fluorimetry complies with the following additional test.*

**FLUORESCENCE** — Under radiation at about 365 nm, the fluorescence measured at about 460 nm is not more intense than that of a solution containing 0.002 mg per ml of *quinine* in 0.05 M sulphuric acid.

**Cysteine Hydrochloride;**  $\alpha$ -Amino-b-mercaptopropionic Acid Hydrochloride:  $[\text{SHCH}_2\text{CH}(\text{NH}_2)\text{CO}_2\text{H}]\cdot\text{HCl} = 157.66$

White crystals; mp, about 177°, with decomposition.

**Cysteine Hydrochloride Solution:** Dissolve 0.5 g of *cysteine hydrochloride*, accurately weighed, in 10 ml of *water* and adjust the pH to 7.0.

The solution should be freshly prepared.

**1-Decanol;** Decan-1-ol:  $\text{C}_{10}\text{H}_{22}\text{O} = 158.28$

General laboratory reagent grade of commerce.

Moderately viscous liquid; wt. per ml, about 0.83 g.

**Dequalinium Chloride:** Of the Indian Pharmacopoeia.

**Destaining solution.** A mixture consisting of 1 volume of *glacial acetic acid*, 4 volume of *methanol* and 5 volume of *water*.

**Dextrose, Anhydrous:** Of the Indian Pharmacopoeia.

**Diammonium Hydrogen Citrate:**  $(\text{NH}_4)_2\text{C}_6\text{H}_6\text{O}_7 = 226.19$

General laboratory reagent grade of commerce.

**Diatomaceous Support, Acid-washed, Silanised:** Use a suitable laboratory reagent grade of commerce.

*Acid-washed diatomaceous support* that has been silanised with dimethyldichlorosilane or other suitable silanising agents.

**Diazobenzenesulphonic Acid Solution:** Heat 0.2 g of *sulphanilic acid* with 20 ml of 1 M hydrochloric acid until dissolved, cool to about 4° and add, dropwise, 2.2 ml of a 4 per cent w/v solution of *sodium nitrite*, swirling continuously. Allow to stand in ice for 10 minutes and add 1 ml of a 5 per cent w/v solution of *sulphamic acid*.

**Diazobenzenesulphonic Acid Solution, Dilute:** Dissolve 0.9 g of *sulphanilic acid* in a mixture of 30 ml of 2 M hydrochloric acid and 70 ml of *water*. To 3 ml of this solution add 3 ml of a 5 per cent w/v solution of *sodium nitrite*. Cool in ice for 5 minutes, add 12 ml of the *sodium nitrite* solution and cool again. Dilute the solution to 100 ml with *water* and keep the

reagent in ice. Prepare extemporaneously but allow to stand for 15 minutes before use.

**Dibenzosuberone**; Dibenzo[*a,d*]cyclohepta-1,4-dien-3-one; 10,11-Dihydro-5*H*-dibenzo[*a,d*]-cyclohepten-5-one:  $C_{15}H_{12}O = 208.26$

General laboratory reagent grade of commerce.

Mp, about 24°.

**Di-*n*-butylamine**:  $C_8H_{18}N = 129.25$

General laboratory reagent grade of commerce.

bp, about 159°; refractive index at 20°, about 1.417.

**Dibutyl Ether**:  $C_8H_{18}O = 130.22$

General laboratory reagent grade of commerce.

Colourless, flammable liquid; bp, about 140°; wt. per ml. About 0.77 g.

Do not distill unless the dibutyl ether complies with the test for peroxides.

**PEROXIDES** — Place 8 ml of *starch iodide solution* in a 12 ml glass-stoppered cylinder about 1.5 cm in diameter. Fill completely with the reagent under examination, shake vigorously and allow to stand protected from light for 30 minutes; no colour is produced.

**Dibutyl Phthalate**: Of the Indian Pharmacopoeia.

**Dichloroacetic Acid**:  $C_2H_2Cl_2O_2 = 128.95$

General laboratory reagent grade of commerce.

bp, about 193°; refractive index at 20°, about 1.466; wt. per ml, about 1.563 g.

**Dichloroacetic Acid Solution**: Dilute 67 ml of *dichloroacetic acid* to 300 ml with *water* and neutralise to *litmus paper* using *10 M ammonia*. Cool, add 33 ml of *dichloroacetic acid* and dilute with *water* to 600 ml.

**1,2-Dichloroethane**; Ethylene Chloride:  $ClCH_2CH_2Cl = 98.96$

Analytical reagent grade of commerce.

Colourless liquid; odour, similar to that of chloroform; bp, about 83°; wt. per ml, about 1.25 g.

**1,2-Dichloroethane, Purified**: Purify *1,2-dichloroethane* by passing through a column of granular *silica gel* (20 to 200 mesh).

**2,7-Dichlorofluorescein**:  $C_{20}H_{10}Cl_2O_5 = 401.19$

Adsorption indicator grade of commerce.

Yellowish brown to yellowish orange powder.

**5,7-Dichloro-8-hydroxyquinoline**;

5,7-Dichloroquinolin-8-ol:  $C_9H_5Cl_2NO = 214.05$

General laboratory reagent grade of commerce.

Yellow-tan crystals; mp, about 181°.

**Dichloromethane**; Methylene Chloride:  $CH_2Cl_2 = 84.93$

Analytical reagent grade of commerce.

Volatile, sweet-smelling liquid; bp, about 40; wt. per ml, about 1.32 g.

*Dichloromethane intended for use in fluorimetry complies with the following additional test.*

**FLUORESCENCE** — Under radiation at about 365 nm, the *fluorescence* measured at about 460nm is not more intense than that of a solution containing 0.002 mg per ml of *quinine* in *0.05 M sulphuric acid*.

**Dichloromethane IR**: Spectroscopic reagent grade of commerce.

**2,6-Dichlorophenolindopheno Sodium**; Tillman's Reagent; Sodium salt of 2,6-dichloro-*N*-(4-hydroxy-phenyl)-1,4-benzoquinone monoimine:  $C_6H_2Cl_2:N:C_6H_4ONa, 2H_2O = 326.11$

Analytical reagent grade of commerce.

Dark green powder.

**2,6-Dichlorophenolindophenol Solution**: Warm 0.1 g of 2,6-dichlorophenolindophenol sodium with 100 ml of *water* and filter.

Must not be used later than 3 days after preparation.

**2,6-Dichlorophenolindophen Standard Solution**:

Dissolve 50 mg of 2,6-dichlorophenolindophenol sodium in 100 ml of *water* and filter. Dissolve 20.0 mg of *L-ascorbic acid* in 10 ml of a freshly prepared 20 per cent w/v solution of *metaphosphoric acid* and dilute to 250 ml with *water*. Titrate 5.0 ml rapidly with the 2,6-dichlorophenolindophenol solution, added from a microburette graduated in units of 0.01 ml, until the pink colour of the dye persists for 10 seconds, the titration taking not more than 2 minutes. Dilute the 2,6-dichlorophenolindophenol solution with *water* so that 1 ml of the solution is equivalent to 0.1 mg of ascorbic acid,  $C_6H_8O_6$ .

The solution must not be used later than 3 days after preparation and must be standardised immediately before use.

**2,6-Dichloroquinone-4-chloromide**; Dichloroquinone-chloroimine:  $C_6H_2Cl_3NO = 210.45$

General laboratory reagent grade of commerce.

Yellow or orange crystalline powder; mp, about 66°.

**Dicyandiamide**:  $C_2H_4N_4 = 84.08$

General laboratory reagent grade of commerce.

White, crystalline powder; mp, about 211°.

**Di-2-cyanoethyl Ether**; (2-Cyanoethyl)-ether:  $C_{12}H_{23}N = 124.14$ .

Chromatographic grade of commerce.

bp, about 111°; refractive index at 20°, 1.4400.

**Dicyclohexylamine:** *N,N*-Dicyclohexylamine:  $C_{12}H_{23}N = 181.32$

General reagent grade of commerce.

Colourless liquid; refractive index at 20°, about 1.484; freezing point, 0° to 1°; boiling point, about 256°.

**1,3-Dicyclohexylurea:**  $C_{13}H_{24}N_2O = 224.34$

General laboratory reagent grade of commerce.

mp, about 232°.

**2,5-Diethoxytetrahydrofuran:**  $C_8H_{16}O_3 = 160.21$

General laboratory reagent grade of commerce consisting of a mixture of *cis*- and *trans*- isomers.

Colourless or slightly yellow liquid; wt. per ml, about 0.97 g.

**Diethylamine:**  $C_{14}H_{11}N = 73.14$

Analytical reagent grade of commerce.

A volatile, colourless liquid; bp, about 55°, relative density (2.4.29), about 0.71.

**Diethylaminoethylcellulose:** Chromatographic grade of commerce.

***N,N*-Diethylaniline:**  $C_{10}H_{15}N = 149.23$

General laboratory reagent grade of commerce.

Pale yellow liquid with an ammoniacal odour; bp, about 217°; wt. per ml, about 0.93 g.

**Diethylene Glycol;** Digol:  $(CH_2OHCH_2)_2O = 106.12$

Analytical reagent grade of commerce.

Clear, colourless liquid; wt. per ml, about 1.12 g.

**Diethylene Glycol Succinate Polyester:** Gas chromatographic reagent grade of commerce.

***N,N*-Diethylethylenediamine;** *N,N*-Diethyl-1, 2-diaminoethane:  $C_6H_{16}N_2 = 116.21$

General laboratory reagent grade of commerce.

Colourless or slightly yellow, slightly oily liquid with a strong odour of ammonia; bp, about 146°; wt. per ml, about 0.83 g.

Complies with the following additional test.

**WATER** (2.3.43) — Not more than 1.0 per cent determined on 0.5 g.

**Digitoxin:** Of the Indian Pharmacopoeia.

**Digitoxin Reagent:** Add 98 ml of *glacial acetic acid* to 2 ml of *sulphuric acid* and add 0.1 ml of a 5 per cent w/v solution of *anhydrous ferric chloride* in *glacial acetic acid*.

**1,5-Di-iodopentane:**  $C_5H_{10}I_2 = 323.94$

General laboratory reagent grade of commerce.

Colourless liquid; bp, about 101°.

**5,7-Di-iodo-8-hydroxyquinoline;**

5,7-Di-iodoquinolin-8-ol:  $C_9H_5I_2NO = 396.95$

General laboratory reagent grade of commerce.

mp, about 214°, with decomposition.

**Di-isopropylamine:**  $[(CH_3)_2CH]_2NH = 101.19$

Colourless liquid; refractive index at 20°, 1.3915 to 1.3935; contains not less than 98 per cent of  $C_6H_{15}N$ .

**ASSAY** — Determined by gas chromatography (2.4.13).

Chromatographic system

- a stainless steel column 1.8 m x 3.2 mm, packed with a cross-linked polystyrene support,
- temperature: column 250° and of the detector at 310°, the column temperature being programmed to rise at 10° per minute from 50° to 220
- flame ionisation detector

**Di-isopropyl Ether;** Isopropyl Ether:  $[(CH_3)_2CH]_2O = 102.18$

General laboratory reagent grade of commerce.

Colourless liquid with a characteristic odour; bp, about 68°; wt. per ml, about 0.72 g.

**NOTE** — *Do not distil unless the di-isopropylether complies with the test for peroxides.*

**PEROXIDES** — Place 8 ml of *starch iodide solution* in a 12-ml glass-stoppered cylinder about 1.5 cm in diameter. Fill completely with the reagent under examination, shake vigorously and allow to stand protected from light for 30 minutes; no colour is produced.

Store protected from light. The name and concentration of any added stabiliser are stated on the label.

**Dimethicone:** Of the Indian Pharmacopoeia.

**2,5-Dimethoxybenzaldehyde:**  $C_9H_{10}O_3 = 166.18$

General laboratory reagent grade of commerce.

mp, about 50°.

**Dimethylacetamide:**  $C_4H_9NO = 87.12$

General laboratory reagent grade of commerce.

Colourless liquid; bp, about 165°; wt per ml, about 0.94 g.

**Dimethylamine:** *N*-Methylmethanamine:  $C_2H_7N = 45.08$

Use analytical grade of *commerce*.

**Dimethylamine solution:** A 40 per cent w/w solution of *dimethylamine* in *water*.

**4-Dimethylaminobenzaldehyde;** *p*-Dimethylaminobenzaldehyde; Dimethylaminobenzaldehyde:  $C_9H_{11}NO = 149.19$

Analytical reagent grade of commerce.

White or pale yellow, crystalline powder; mp, about 74°.

**Dimethylaminobenzaldehyde solution:** Dissolve 0.2 g of *4-dimethylaminobenzaldehyde* in 20 ml of *ethanol* (95 per cent) and add 0.5 ml of *hydrochloric acid*. Shake the solution with *activated charcoal* and filter. The colour of the solution is not more intense than that of freshly prepared 0.0001 M *iodine*. Prepare immediately before use.

**Dimethylaminobenzaldehyde Reagent:** Dissolve 0.125 g of *4-dimethylaminobenzaldehyde* in a cooled mixture of 65 ml of *sulphuric acid* and 35 ml of *water* and add 0.1 ml of *ferric chloride test solution*. Allow to stand for 24 hours in the dark before use.

When stored at room temperature, it must be used within one week. It may be stored in a refrigerator for several months. Discard the solution when a yellow colour develops.

**Dimethylaminobenzaldehyde Solution, Ethanolic;** Alcoholic Dimethylaminobenzaldehyde Solution: Dissolve 1 g of *4-dimethylaminobenzaldehyde* in 30 ml of *ethanol* (95 per cent) and add 180 ml of *1-butanol* and 30 ml of *hydrochloric acid*.

**4-Dimethylaminocinnamaldehyde:**  $C_{11}H_{13}NO = 175.23$

General laboratory reagent grade of commerce.

Orange or orange brown crystals or powder; mp, about 138°.

**Dimethylaniline;** *N,N*-Dimethylaniline:  $C_8H_{11}N = 121.18$

Analytical reagent grade of commerce.

Clear liquid which darkens on storage; bp, about 193°; refractive index at 20°, 1.557 to 1.5591; wt. per ml, about 0.96 g.

**2,3-Dimethylaniline;** 2,3-Xylidine:  $C_8H_{11}N = 121.18$

General laboratory reagent grade of commerce.

Colourless liquid; bp, about 221°; refractive index at 20°, about 1.568; wt. per ml, about 0.99 g.

**2,6-Dimethylaniline;** 2,6-Xylidine:  $C_8H_{11}N = 121.18$

General laboratory reagent grade of commerce.

Colourless liquid; wt. per ml, about 0.98.

**Dimethylformamide:**  $C_3H_7NO = 73.09$

Analytical reagent grade of commerce.

Colourless liquid; bp, about 153°; wt per ml, about 0.95 g.

Complies with the following additional test.

**WATER** (2.3.43) — Not more than 0.1 per cent.

**Dimethylformamide Solution (5 per cent v/v):** Dilute 5 ml of *dimethylformamide* to 100 ml with *water*.

**Dimethylglyoxime;** Diacetyldioxime; 2,3-Butanedione dioxime:  $C_4H_8N_2O_2 = 116.12$

Analytical reagent grade of commerce.

White, crystalline powder or colourless crystals; mp, about 240° with decomposition; sulphated ash, not more than 0.05 per cent.

***N,N*-Dimethyl-*p*-phenylenediamine Sulphate;**

*N,N*-Dimethyl-4-phenylenediamine sulphate:  $C_8H_{12}N_2H_2SO_4 = 234.27$

General laboratory reagent grade of commerce.

***N,N*-Dimethyl-*p*-phenylenediamine Sulphate Solution:**

Boil 25 g of *N,N*-dimethyl-*p*-phenylenediamine sulphate with 600 ml of *ethanol* (90 per cent) under a reflux condenser. When dissolved add *activated charcoal*, mix well and filter whilst hot. Allow to stand overnight and then cool in ice, filter through sintered glass. Wash with ice-cold *ethanol* until free from colour and dry at room temperature at a pressure of 2 kPa. Dissolve 50 mg of the recrystallised material in sufficient *water* to produce 50 ml.

**Dimethyl Phthalate:**  $C_{10}H_{10}O_4 = 194.19$

General laboratory reagent grade of commerce.

Colourless or faintly coloured liquid; wt per ml, about 1.19 g; contains not less than 99.0 per cent and not more than 100.5 per cent w/w of  $C_{10}H_{10}O_4$ .

**ASSAY** — Carry out the method for the determination of esters (2.3.25), using 1.5 g and 50 ml of 0.5 M *ethanolic potassium hydroxide*. 1 ml of 0.5 M *ethanolic potassium hydroxide* is equivalent to 0.04855 g of  $C_{10}H_{10}O_4$ .

***N,N'*-Dimethylpiperazine;** Dimethylpiperazine; 1,4-Dimethylpiperazine:  $C_6H_{14}N_2 = 114.20$

General laboratory reagent grade of commerce.

Colourless liquid with a characteristic odour; bp, about 131°; wt per ml, about 0.84 g.

**Dimethyl Sulphoxide:**  $(CH_3)_2SO = 78.13$

General Laboratory reagent grade of commerce.

Clear, colourless, viscous liquid, odourless or with a slight, but unpleasant odour; hygroscopic; bp about 192°; wt per ml, about 1.103 g.

**1,3-Dinitrobenzene:**  $C_6H_4(NO_2)_2 = 168.11$

General laboratory reagent grade of commerce.

Pale yellow needles; mp, about 90°.

**Dinitrobenzene Solution:** A 1 per cent w/v solution of 1,3-dinitrobenzene in *ethanol* (95 per cent).

**3,5-Dinitrobenzoic Acid;** Dinitrobenzoic Acid:  $C_7H_4N_2O_6 = 212.12$

General laboratory reagent grade of commerce.

Almost colourless crystals; mp, about 206°.



**Dinitrobenzoic Acid Solution:** A 2.0 per cent w/v solution of 3,5-dinitrobenzoic acid in ethanol (95 per cent).

**2,4-Dinitrophenylhydrazine;** Dinitrophenylhydrazine:  $C_6H_6N_4O_4 = 198.14$

Analytical reagent grade of commerce.

Reddish orange crystals or crystalline powder; mp, about 203°.

**Dinitrophenylhydrazine-Aceto-Hydrochloric Acid Solution;** Dinitrophenylhydrazine Reagent: Dissolve 0.2 g of 2,4 dinitrophenylhydrazine in 20 ml of methanol and add 80 ml of a mixture of equal volumes of 7 M hydrochloric acid and 5 M acetic acid.

Prepare immediately before use.

**Dinitrophenylhydrazine Solution:** Dissolve 1.5 g of 2,4 dinitrophenylhydrazine in 20 ml of sulphuric acid (50 per cent v/v). Dilute to 100 ml with water and filter. The solution must be freshly prepared.

**Diocetyl Sodium Sulphosuccinate:**  $C_{20}H_{37}NaO_7S = 444.56$

General laboratory reagent grade of commerce.

White, waxy flakes; usually contains about 90 per cent of  $C_{20}H_{37}NaO_7S$ .

**Dioxan;** 1,4-Dioxan; Diethylene Dioxide:  $C_4H_8O_2 = 88.11$

Analytical reagent grade of commerce.

Colourless liquid with an ethereal odour; bp, about 101°; wt. per ml, about 1.03 g.

Do not distil unless the dioxan complies with the test for peroxides.

**PEROXIDES** — Place 8 ml of starch iodide solution in a 12-ml glass-stoppered cylinder about 1.5 cm in diameter. Fill completely with the reagent under examination, shake vigorously and allow to stand protected from light for 30 minutes; no colour is produced.

**Diphenyl:**  $C_{12}H_{10} = 154.21$

General laboratory reagent grade of commerce.

White crystals or crystalline powder; odour, characteristic; mp, about 70°.

**Diphenylamine:**  $(C_6H_5)_2NH = 169.23$

Analytical reagent grade of commerce.

White crystals; odour, characteristic; mp, about 55°.

Store protected from light.

**Diphenylamine Solution:** A 0.1 per cent w/v solution of Diphenylamine in sulphuric acid.

Store protected from light.

**9,10-diphenylanthracene;** Diphenylanthracene:  $C_{26}H_{18} = 330.43$ .

General laboratory reagent grade of commerce.

mp, about 248°.

**N,N'-Diphenylbenzidine:** Diphenylbenzidine:  $C_{24}H_{20}N_2 = 336.42$

General laboratory reagent grade of commerce.

White or faintly grey, crystalline powder; mp, about 248°.

Complies with the following test.

**NITRATE** — Dissolve 8 mg in a cooled mixture of 45 ml of nitrogen free sulphuric acid and 5 ml of water; the solution is colourless or very pale blue.

Store protected from light.

**1,5-Diphenylcarbazine:** Diphenylcarbazine:  $C_{13}H_{14}N_4O = 242.28$

Analytical reagent grade of commerce.

White, crystalline powder gradually turning pink on exposure to air; mp, about 170°.

Store protected from light.

**Diphenylcarbazine Solution:** Dissolve 0.2 g of 1,5-diphenylcarbazine in 10 ml of glacial acetic acid and dilute to 100 ml with ethanol.

Prepare immediately before use.

**1,5-Diphenylcarbazono;** Diphenylcarbazono;  $C_{13}H_{12}N_4O = 240.26$

General laboratory reagent grade of commerce.

Orange, crystalline powder; mp, about 157°, decomposition.

**Diphenylcarbazono Mercuric Reagent:** Diphenylcarbazono-Mercury Reagent: Dissolve 0.1 g of 1,5 diphenylcarbazono in sufficient ethanol to produce 50 ml and, separately, dissolve 1 g of mercuric chloride in sufficient ethanol to produce 50 ml. Mix equal volumes of the two solutions.

**Dipotassium Hydrogen Phosphate:** Dipotassium Hydrogen Orthophosphate; Dibasic Potassium Phosphate:  $K_2HPO_4 = 174.17$

Analytical reagent grade of commerce.

White granules; somewhat hygroscopic.

**Dipotassium Hydrogen Phosphate, 0.1 M:** Dissolve 17.417 g of dipotassium hydrogen phosphate in sufficient water to produce 1000 ml.

**Disodium Edetate:** Of the Indian Pharmacopoeia.

**Disodium Edetate, x M:** Solutions of any molarity xM may be prepared by dissolving 372.2x g of disodium edetate in sufficient water to produce 1000 ml.

**Disodium Hydrogen Phosphate:** See Sodium Phosphate of the Indian Pharmacopoeia.

**Disodium Hydrogen Phosphate x M:** Solutions of any molarity xM may be prepared by dissolving 358.15x g of *disodium hydrogen phosphate* in sufficient *water* to produce 1000 ml.

**Disodium Hydrogen Phosphate, Anhydrous;** Disodium Hydrogen Orthophosphate, Anhydrous; Anhydrous Sodium Phosphate:  $\text{Na}_2\text{HPO}_4 = 141.95$

Analytical reagent grade of commerce.

Hygroscopic powder; absorbs 2 to 7 mols of  $\text{H}_2\text{O}$  when exposed to air.

Store protected from moisture.

**Disodium Hydrogen Phosphate Solution:** A 10.0 per cent w/v solution of *disodium hydrogen phosphate* in *water*.

**5,5'-Dithiobis(2-nitrobenzoic acid);** 3-Carboxy-4-nitrophenyl Disulphide; Ellman's Reagent:  $\text{C}_{14}\text{H}_8\text{N}_2\text{O}_8\text{S}_2 = 396.35$

Yellow powder; mp, about 242°

**Dithiothreitol:**  $\text{C}_4\text{H}_{10}\text{O}_2\text{S}_2$ ; Mol. Wt. 154.2

Slightly hygroscopic needles from either, mp 42°-43°.

**Dithizone;** 1,5-Diphenylthiocarbazon; Diphenylthiocarbazon;  $\text{C}_6\text{H}_5\text{N}:\text{NCSNHHC}_6\text{H}_5 = 256.32$

Analytical reagent grade of commerce.

Almost black powder; mp, about 168°, with decomposition.

Store protected from light.

**Dithizone-Carbon Tetrachloride Solution:** Dissolve 10 mg of *dithizone* in 1000 ml of *carbon tetrachloride*. Prepare this solution fresh for each determination.

**Dithizone Extraction Solution:** Dissolve 30 mg of *dithizone* in 1000 ml of *chloroform* and add 5 ml of *ethanol (95 per cent)*. Store the solution in a refrigerator. Before use, shake a suitable volume of the solution with about half its volume of a 1 per cent v/v solution of *nitric acid* and discard the acid.

**Dithizone solution:** A 0.05 per cent w/v solution of *dithizone* in *chloroform*.

Prepare immediately before use.

**Dithizone Standard Solution:** Dissolve 10 mg of *dithizone* in 1000 ml of *chloroform*. Store the solution in a glass-stoppered, lead-free, light-resistant bottle in a refrigerator.

**Domiphen Bromide;** Dodecyldimethyl-2-phenoxy-ethylammonium bromide:  $\text{C}_{22}\text{H}_{40}\text{BrNO} = 414.47$

Colourless or faintly yellow, crystalline flakes; mp, about 111°; contains not less 97.0 per cent and not more than 100.5 per cent of  $\text{C}_{22}\text{H}_{40}\text{BrNO}$ , calculated with reference to the dried substance.

**ASSAY** — Dissolve 2 g of *domiphen bromide* in sufficient *water* to produce 100 ml. Transfer 25 ml to a separating funnel and add 25 ml of *chloroform*, 10 ml of 0.1 M *Sodium hydroxide* and 10 ml of a freshly prepared 5 per cent w/v solution of *potassium iodide*. Shake well, allow to separate and discard the *chloroform* layer. Wash the aqueous layer with three quantities, each of 10 ml, of *chloroform* and discard the *chloroform* solutions. Add 40 ml of *hydrochloric acid*, allow to cool and titrate with 0.05 M *potassium iodate* until the deep brown colour is discharged. Add 2 ml of *chloroform* and continue the titration shaking vigorously until the *chloroform* layer no longer changes colour. Perform a blank determination using a mixture of 10 ml of the freshly prepared *potassium iodide solution*, 20 ml of *water* and 40 ml of *hydrochloric acid*. The difference between the titrations represents the amount of *potassium iodate* required.

1 ml of 0.05 M *Potassium iodate* is equivalent to 0.04145 g of  $\text{C}_{22}\text{H}_{40}\text{BrNO}$ .

**Dotriacontane:**  $\text{C}_{32}\text{H}_{66} = 450.87$

General laboratory reagent grade of commerce.

White plates; mp, about 69°.

**IMPURITIES** — Not more than 0.1 per cent of impurities with the same retention time as *a-tocopherol acetate* when determined by gas chromatography (2.4.13).

#### Dragendorff Reagent

**SOLUTION I** — Dissolve 0.85 g of *bismuth subnitrate* in 10 ml of *glacial acetic acid* and 40 ml of *water* with the aid of heat and filter, if necessary.

**SOLUTION II** — Dissolve 8 g of *potassium iodide* in 30 ml of *water*.

Stock solution: Solutions I and II are equally mixed.

Spray reagent: 1 ml of stock solution is mixed with 2 ml of *glacial acetic acid* and 10 ml of *water*.

Prepare immediately before use.

**Electrolyte reagent for the determination of water:** Commercially available anhydrous reagent or a combination of anhydrous reagents for the coulometric titration of *water*, containing suitable organic basis, *sulphur dioxide* and *iodide* dissolved in a suitable solvent.

**Ergocalciferol:** Of the Indian Pharmacopoeia.

**Ethanol:** Of the Indian Pharmacopoeia.

**Ethanol (95 per cent):** of the Indian Pharmacopoeia.

**Ethanol (x per cent):** Diluted *ethanols* may be prepared by diluting the volumes of *ethanol (95 per cent)* indicated in the following table to 1000 ml with *water*.

Strength per cent v/v	Volume of ethanol (95 per cent) (g)	Weight per ml (g)
90	947	0.83
80	842	0.86
75	789	0.88
70	737	0.89
60	632	0.91
50	526	0.93
40	421	0.95
25	263	0.97
20	210	0.976

**Ethanol, Aldehyde-free:** Aldehyde-free Ethanol (95 per cent); mix 1200 ml of *ethanol (95 per cent)* with 5 ml of a 40 per cent w/v solution of *silver nitrate* and 10 ml of a cooled 50 per cent w/v solution of *sodium hydroxide*. Shake, allow to stand for a few days and filter. Distill the filtrate immediately before use.

Complies with the following additional test.

**ALDEHYDE** — To 25 ml contained in a 300 ml flask add 75 ml of *dinitrophenylhydrazine solution*, heat on a *water bath* under a reflux condenser for 24 hours, remove the *ethanol* by distillation, dilute to 200 ml with a 2 per cent v/v solution of *sulphuric acid* and set aside for 24 hours; no crystals are produced.

**Ether:** Diethyl Ether; Solvent Ether;  $(C_2H_5)_2O = 74.12$

Analytical reagent grade of commerce.

Volatile, highly flammable colourless liquid; bp, about 34°; wt per ml, about 0.71 g.

**NOTE** — Do not determine the boiling range or distil unless the ether complies with the test for peroxides.

**PEROXIDES** — Place 8 ml of *starch iodide solution* in a 12 ml glass stoppered cylinder about 1.5 cm in diameter. Fill completely with the reagent under examination shake vigorously and allow to stand protected from light for 30 minutes; no colour is produced.

Store protected from light at a temperature not exceeding 15°. The name and concentration of any added stabilizer are stated on the label.

**Ether, Peroxide-free:** Shake 1000 ml of *ether* with 20 ml of a solution of 30 g of *ferrous sulphate* in 55 ml of *water* and 3 ml of *sulphuric acid*. Continue shaking until a small sample no longer produces a blue colour when shaken with an equal volume of a 2 per cent w/v solution of potassium *iodide* and 0.1 ml of *starch mucilage*.

**p-Ethoxychrysoidine Hydrochloride:** 4-p-Ethoxyphenylazo-m-phenylenediamine Hydrochloride:  $C_{14}H_{16}N_4OHCl = 292.76$

General laboratory reagent grade of commerce.

Red powder.

**Ethoxychrysoidine Hydrochloride Solution:** A 0.1 per cent w/v solution of *p-ethoxychrysoidine hydrochloride* in *ethanol (95 per cent)*.

Complies with the following test.

**SENSITIVITY TO BROMINE** — To a mixture of 0.05 ml and 5 ml of *2 M hydrochloric acid* add 0.05 ml of *0.0167 M bromine*; the colour changes from red to light yellow within 2 minutes.

**Ethyl Acetate:**  $CH_3COOC_2H_5 = 88.11$

Analytical reagent grade of commerce.

Colourless liquid with a fruity odour; bp, about 77°; wt. per ml, about 0.90 g.

**Ethyl Cyanoacetate:**  $CNCH_2CO_2C_2H_5 = 113.12$

Analytical reagent grade of commerce.

Colourless or almost colourless liquid; wt. per ml, about 1.06 g.

**Ethylenediamine:** 1,2-Diaminoethane:  $NH_2CH_2CH_2NH_2 = 60.10$

General laboratory reagent grade of commerce.

Colourless, clear, thick liquid with ammonical odour; bp, about 118°; refractive index at 20°, about 1.457; wt. per ml, about 0.90 g.

**Ethylene Glycol:** 1,2-Ethanediol; Ethane-1,2-diol:  $C_2H_6O_2 = 62.07$

General laboratory reagent grade of commerce.

Slightly viscous liquid; taste, sweet; considerably hygroscopic; bp, about 198°.

**N-Ethylglucamine:** Eglumine; 1-Deoxy-1-ethylamino-D-glucitol:  $C_8H_{19}O_5 = 209.24$ .

General commercial grade.

mp, about 138°.

**N-Ethylglucamine Hydrochloride:**  $C_8H_{19}O_5, HCl = 245.70$ .

General commercial grade.

mp, about 132°.

**2-Ethylhexanoic Acid:** 2-Ethylhexoic Acid:  $C_8H_{16}O_2 = 144.21$

General laboratory reagent grade of commerce.

Colourless liquid; wt. per ml, about 0.91 g; refractive index at 20°, about 1.425.

Complies with the following test.

**RELATED SUBSTANCES** — Determine by gas chromatography (2.4.13).

Using 1 ml of a solution prepared in the following manner. Suspend 0.2 g in 5 ml of *water*, add 3 ml of *2 M hydrochloric acid* and 5 ml of *hexane*, shake for 1 minute, allow the layers to separate and use the upper layer.

The chromatographic system described in the test for 2-Ethylhexanoic Acid in the monograph for Amoxicillin Sodium may be used.

The sum of the areas of any secondary peaks is not greater than 2.5 per cent of the area of the principal peak.

**2-Ethyl-2-methylsuccinic Acid;** 2-Ethyl-2-methyl-butanedioic Acid:  $C_7H_{12}O_4=160.17$

General reagent grade of commerce.

mp, about  $106^\circ$ .

**Eugenol;** 4-Allyl-2-methoxyphenol:  $C_{10}H_{12}O_2=164.20$

General laboratory reagent grade of commerce.

Colourless or pale yellow, oily liquid; wt. per ml, about 1.07 g.

For the determination of eugenol in volatile oils, use a grade of commerce containing not less than 99.0 per cent of  $C_{10}H_{12}O_2$ .

Store protected from light.

**Euglobulins, Bovine:** For the preparation, use fresh bovine blood collected into an anticoagulant solution (for example sodium citrate solution). Discard any haemolysed blood. Centrifuge at 1500 to 1800 g between  $15^\circ$  and  $20^\circ$  to obtain a supernatant plasma poor in platelets.

To 1 litre of the bovine plasma add 75 g of *barium sulphate* and shake for 30 minutes. Centrifuge at 1500 to 1800 g between  $15^\circ$  and  $20^\circ$  and draw off the clear supernatant liquid. Add 10 ml of a 0.02 per cent w/v solution of *aprotinin* and shake to ensure mixing. In a container with a minimum capacity of 30 litres in a chamber at  $4^\circ$  introduce 25 litres of *distilled water* at  $4^\circ$  and add about 500 g of solid carbon dioxide. Immediately add, while stirring, the supernatant liquid obtained from the plasma; a white precipitate is produced. Allow to settle at  $4^\circ$  for 10 to 15 hours. Remove the clear supernatant solution by siphoning. Collect the precipitate by centrifugation at  $4^\circ$ . Suspend the precipitate by dispersing mechanically in 500 ml of *distilled water* at  $4^\circ$ , shake for 5 minutes and collect the precipitate by centrifugation at  $4^\circ$ . Disperse the precipitate mechanically in 60 ml of a solution containing 0.9 per cent w/v of *sodium chloride* and 0.09 per cent w/v of *sodium citrate* and adjust the pH to 7.2 to 7.4 by adding a 1 per cent w/v solution of *sodium hydroxide*. Filter through a sintered-glass filter; to facilitate the dissolution of the precipitate crush the particles of the precipitate with a suitable implement. Wash the filter and the implement with 40 ml of the chloride-citrate solution described above and dilute to 100 ml with the same solution. Freeze-dry the solution. The yields are generally 6 to 8 g of euglobulins per litre of bovine plasma.

Complies with the following test.

**SUITABILITY TEST** — For this test, prepare the solutions using *phosphate buffer pH 7.4* containing 3 per cent w/v of *bovine albumin*. In to a test-tube, 8 mm in diameter placed in a water-

bath at  $37^\circ$ , introduce 0.2 ml of a solution of a reference preparation of urokinase containing 100 Units of urokinase activity per ml and 0.1 ml of a solution of *thrombin* containing 20 Units per ml. Add rapidly 0.5 ml of a solution containing 10 mg of the euglobulin fraction per ml; a firm clot is produced in less than 10 seconds. Note the time that elapses between the addition of the solution of the euglobulin fraction and the lysis of the clot. The lysis time does not exceed 15 minutes.

Store protected from moisture at  $4^\circ$  and use within 1 year.

**Euglobulins, Human:** For the preparation, use fresh human blood collected into an anticoagulant solution (for example sodium citrate solution) or human blood for transfusion collected into plastic blood bags that has just reached its expiry date. Discard any haemolysed blood. Centrifuge at 1500 to 1800 g at  $15^\circ$  to obtain a supernatant plasma poor in platelets. Iso-group plasmas may be mixed.

To 1 litre of the human plasma add 75 g of *barium sulphate* and shake for 30 minutes. Centrifuge at not less than 15000 g at  $15^\circ$  and draw off the clear supernatant liquid. Add 10 ml of a 0.02 per cent w/v solution of *aprotinin* and shake to ensure mixing. In a container with a minimum capacity of 30 litres in a chamber at  $4^\circ$  introduce 25 litres of *distilled water* at  $4^\circ$  and add about 500 g of solid carbon dioxide. Immediately add, while stirring, the supernatant liquid obtained from the plasma; a white precipitate is produced. Allow to settle at  $4^\circ$  for 10 to 15 hours. Remove the clear supernatant solution by siphoning. Collect the precipitate by centrifuging at  $4^\circ$ . Suspend the precipitate by dispersing mechanically in 500 ml of *distilled water* at  $4^\circ$ , shake for 5 minutes and collect the precipitate by centrifuging at  $4^\circ$ . Disperse the precipitate mechanically in 60 ml of a solution containing 0.9 per cent w/v of *sodium chloride* and 0.09 per cent w/v of *sodium citrate* and adjust the pH to 7.2 to 7.4 by adding a 1 per cent w/v solution of *sodium hydroxide*. Filter through a sintered-glass filter; to facilitate the dissolution of the precipitate crush the particles of the precipitate with a suitable implement. Wash the filter and the implement with 40 ml of the chloride-citrate solution described above and dilute to 100 ml with the same solution. Freeze dry the solution. The yields are generally 6 to 8 g of euglobulins per litre of human plasma.

Complies with the following test.

**SUITABILITY TEST** — Carry out the test described under Bovine Euglobulins using *citro-phosphate buffer pH 7.2* containing 3 per cent w/v of *bovine albumin*.

Store in tightly-closed containers at  $4^\circ$  and use within 1 year.

**Ferric Ammonium Sulphate;** Ammonium Iron (III) Sulphate; Ferric Alum:  $Fe(NH_4)(SO_4)_2 \cdot 12H_2O=482.18$

Analytical reagent grade of commerce.

Pale violet crystals or nearly colourless crystalline powder.



**Ferric Ammonium Sulphate Solution:** An 8.0 per cent w/v solution of *ferric ammonium sulphate*.

**Ferric Ammonium Sulphate Solution, Acid:** Dissolve 0.2 g of *ferric ammonium sulphate* in 50 ml of *water*, add 6 ml of *dilute nitric acid* and add sufficient *water* to produce 100 ml.

**Ferric Chloride;** Anhydrous Ferric Chloride; Iron(III) Chloride; Anhydrous Iron(III) Chloride:  $\text{FeCl}_3 = 162.22$

General laboratory reagent grade of commerce.

Greenish black crystals or crystalline powder, free from the orange colour of the hydrated salt, which is readily acquired by exposure to atmospheric moisture.

#### Ferric Chloride-Ferricyanide-Arsenite Solution

**SOLUTION I** — Dissolve 2.7 g of *ferric chloride hexahydrate* in 100 ml of 2 M of *hydrochloric acid*.

**SOLUTION II** — Dissolve 3.5 g of *potassium ferricyanide* in 100 ml of *water*.

**SOLUTION III** — Dissolve 3.8 g of *arsenic trioxide* in 25 ml of hot 2 M *sodium hydroxide*. Allow to cool, add 50 ml of 1 M *sulphuric acid* and dilute with *water* to 100 ml.

Immediately before use mix 5 volumes of solution I, 5 volumes of solution II and 1 volume of solution III.

**Ferric Chloride Hexahydrate;** Iron(III) Chloride Hexahydrate:  $\text{FeCl}_3 \cdot 6\text{H}_2\text{O} = 270.32$

Analytical reagent grade of commerce.

Brownish yellow or orange monoclinic crystals; very hygroscopic.

**Ferric Chloride Solution:** A solution prepared from *ferric chloride hexahydrate* so as to contain about 15 per cent w/v of  $\text{FeCl}_3$ .

**Ferric Chloride Test Solution:** A 5.0 per cent w/v solution of *ferric chloride*.

**Ferrous Ammonium Sulphate;** Ammonium Iron(II) Sulphate:  $\text{Fe}(\text{NH}_4)_2(\text{SO}_4)_2 \cdot 6\text{H}_2\text{O} = 392.13$

Analytical reagent grade of commerce.

Pale greenish blue crystals or crystalline powder.

Store in well-closed, light-resistant containers.

**Ferrous Sulphate:** Of the Indian Pharmacopoeia.

**Ferrous Sulphate-Citrate Solution:** Dissolve 1 g of *sodium metabisulphite* in 200 ml of *water*, add 1 ml of 1 M *hydrochloric acid*, 1.5 g of *ferrous sulphate* and 10 g of *sodium citrate*.

The solution must be freshly prepared.

**Ferrous Sulphate Solution:** A 2.0 per cent w/v solution of *ferrous sulphate* in freshly boiled and cooled *water*.

The solution must be freshly prepared.

**Fibrin:** The insoluble protein which separates during the coagulation of blood, washed and shredded.

**Fluorescein;** CI 45350; 3',6'-Fluorandiol; 3',6'-Dihydroxyfluoran; Solvent Yellow 94; 3',6'-Dihydroxyspiro[isobenzofuran-1(3H),9'-[9H]xanthen] 3-one; 9'-(*o*-carboxyphenyl)-6-hydroxy-3H-xanthen-3-one:  $\text{C}_{20}\text{H}_{12}\text{O}_5 = 332.30$

General laboratory reagent grade of commerce.

Yellowish red to red powder; mp, about 315°, with decomposition.

**Fluorescein Sodium:** Of the Indian pharmacopoeia.

**1-Fluoro-2,4-dinitrobenzene;**

2,4-Dinitrofluorobenzene:  $\text{C}_6\text{H}_3\text{FN}_2\text{O}_4 = 186.10$

General laboratory reagent grade of commerce.

Pale yellow, vesicatory crystals, lumps or liquids with a lachrymatory vapour; refractive index at 20°, about 1.569; wt. per ml, about 1.48 g.

**Fluoxymesterone;** 9'-Fluoro-11b,17b-dihydroxy-17a-methylandro-4-en-3-one:  $\text{C}_{20}\text{H}_{29}\text{FO}_3 = 336.45$

General laboratory reagent grade of commerce.

mp, about 229°.

**Folic Acid:** Of the Indian Pharmacopoeia.

**Formaldehyde Solution;** Formalin:  $\text{HCHO} = 30.03$

Analytical reagent grade of commerce.

Colourless, aqueous solution with a lachrymatory vapour; wt. per ml, about 1.08 g; contains not less than 34.0 per cent w/v and not more than 37.0 per cent w/v of  $\text{CH}_2\text{O}$ .

**ASSAY** — Dilute 5 ml to 1000 ml with *water*. To 10 ml of the solution add 25.0 ml of 0.05 M *iodine* and 10 ml of 1 M *sodium hydroxide*. Allow to stand for 5 minutes, add 12 ml of 1 M *hydrochloric acid* and titrate the excess of *iodine* with 0.1 M *sodium thiosulphate* using 1 ml of *starch solution*, added towards the end of the titration, as indicator. Perform a blank determination and make any necessary correction.

1 ml of 0.05 M *iodine* is equivalent to 0.0015 g of  $\text{CH}_2\text{O}$ .

Store protected from moisture, preferably at a temperature not below 15°.

**Formaldehyde Solution, Dilute:** Dilute 34 ml of *formaldehyde solution* with sufficient *water* to produce 100 ml.

**Formamide:**  $\text{HCONH}_2 = 45.04$

Analytical reagent grade of commerce.

Colourless, oily liquid; wt. per ml, about 1.13 g.

**Formic Acid:**  $\text{HCOOH} = 46.03$

Analytical reagent grade of commerce.

Colourless liquid; odour, very pungent; highly corrosive; wt. per ml, about 1.20 g; contains about 90.0 per cent w/v of  $\text{CH}_2\text{O}_2$  and is about 23.6M in strength.

**Formic Acid, 15 M:** Dilute 63.3 ml of *formic acid* to 100ml with *water*.

**Formic Acid, Anhydrous:**  $\text{HCOOH} = 46.03$

Analytical reagent grade of commerce.

Colourless liquid; odour, pungent; highly corrosive; wt. per ml, about 1.22 g; contains not less than 98.0 per cent w/w of  $\text{HCOOH}$ .

**ASSAY** — Weigh accurately a conical flask containing 10ml of *water*, quickly add about 1ml of the reagent under examination and weigh again. Add 50 ml of *water* and titrate with 1 M *sodium hydroxide* using 0.5 ml of *phenolphthalein solution* as indicator. 1ml of 1 M *sodium hydroxide* is equivalent to 0.04603 g of  $\text{HCOOH}$ .

**D-Fructose;** Laevulose:  $\text{C}_6\text{H}_{12}\text{O}_6 = 180.16$

General laboratory reagent grade of commerce.

White, crystalline powder; mp, about  $103^\circ$ , with decomposition;  $[\alpha]_D^{20}$ , about  $92^\circ$  (10 per cent w/v in *water* containing 0.05 ml of 5 M *ammonia*).

**Fusidic Acid:** Of the Indian Pharmacopoeia.

**Gastric Juice, Artificial:** Dissolve 2.0 g of *sodium chloride* and 3.2 g of *pepsin* in *water*. Add 80 ml of 1 M *hydrochloric acid* and dilute to 1000 ml with *water*.

**D-Galactose:**  $\text{C}_6\text{H}_{12}\text{O}_6$

General laboratory reagent grade of commerce.

White, crystalline powder; mp, about  $164^\circ$ ;  $[\alpha]_D^{20}$ , about  $+80^\circ$  (10 per cent w/v in *water* containing 0.05 ml of 5 M *ammonia*).

**Gelatin:** Of the Indian Pharmacopoeia.

**Gelatin Capsule Shells, Hard:** Of the Indian Pharmacopoeia.

**Gelatin, Hydrolysed:** Dissolve 50 g of *gelatin* in 1000ml of *water*, heat in saturated steam at  $121^\circ$  for 90 minutes and freeze-dry.

**Gelatin, Pancreatic Digest of:** Microbiological reagent grade of commerce.

**Gitoxin:**  $\text{C}_{41}\text{H}_{64}\text{O}_{14} = 780.92$

General laboratory reagent grade of commerce.

White, crystalline powder; mp, about  $283^\circ$ , with decomposition;  $[\alpha]_D^{20}$ , about  $+22^\circ$  (0.5 per cent w/v in a mixture of equal volumes of *chloroform* and *methanol*).

Complies with the following additional test.

**HOMOGENEITY** — Determine by thin-layer chromatography (2.4.17), coating the plate with *silica gel G*.

**Mobile phase.** A mixture of 7.5 volumes of *water*, 10 volumes of *methanol* and 75 volumes of *ethyl acetate*.

**Test solution.** Add 20 ml of *ethanol* (50 per cent) and 10 ml of *lead acetate solution* to 1.0 g, in *No.180 powder*, boil for 2 minutes and allow to cool. Centrifuge and extract the clear supernatant liquid with two quantities, each of 15 ml of *chloroform*, separating the layers, if necessary, by centrifugation. Dry the combined extracts over *anhydrous sodium sulphate* and filter. Evaporate 10 ml of this solution to dryness on a water-bath and dissolve the residue in 1 ml of a mixture of equal volumes of *chloroform* and *methanol*.

Apply to the plate 20  $\mu\text{l}$  of the solution as a band, 2 cm x 3 mm. Allow the mobile phase to rise 10 cm. Dry the plate, allow the solvents to evaporate, spray with a mixture of 8 volumes of a 25 per cent w/v solution of *trichloroacetic acid* in *ethanol* (95 per cent) and 2 volumes of a 1 per cent w/v solution of *chloramine T*, heat at  $105^\circ$  for 10 minutes and examine under ultra-violet light at 365 nm. The chromatogram shows only one light blue fluorescent band due to gitoxin.

**Glutamic acid:**  $\text{C}_5\text{H}_9\text{NO}_4 = \text{Mol. Wt. } 147.1$

A white, crystalline powder or colourless crystals.

**Glycine:** Of the Indian Pharmacopoeia.

**Glycerin:** Of the Indian Pharmacopoeia.

**Glycerin (85 per cent):** *Glycerin* containing 12.0 to 16.0 per cent w/w of *water*; wt. per ml, 1.22 to 1.24 g.

**Glycollic Acid;** 2-Hydroxyacetic Acid:  $\text{C}_2\text{H}_4\text{O}_3 = 76.05$

General laboratory reagent grade of commerce.

mp, about  $80^\circ$ .

**Glycyrrhetic Acid;** Glycyrrhetic Acid:  $\text{C}_{30}\text{H}_{46}\text{O}_4 = 470.69$

General laboratory reagent grade of commerce consisting of a mixture of  $\alpha$ - and  $\beta$ -isomers with the  $\beta$ -isomer predominating.

White to brownish yellow powder; mp, about  $292^\circ$ , with decomposition;  $[\alpha]_D^{20}$ ,  $+145^\circ$  to  $+155^\circ$  (1 per cent w/v in *ethanol*).

Complies with the following test.

**HOMOGENEITY** — Determine by thin-layer chromatography (2.4.17), coating the plate with *silica gel F254*, prepared using a 25 per cent v/v solution of *phosphoric acid*, to coat the plate.

**Mobile phase.** A mixture of 5 volumes of *methanol* and 95 volumes of *chloroform*.

**Test solution.** A 0.5 per cent w/v solution of the reagent under examination in the mobile phase

Apply to the plate 5  $\mu$ l of the solution. Allow the mobile phase to rise 10 cm. Dry the plate, examine under ultra-violet light at 254 nm. The chromatogram obtained shows a dark spot with an Rf value of about 0.3 ( $\beta$ -glycyrrhetic acid) and a smaller spot with an Rf value of about 0.5 ( $\alpha$ -glycyrrhetic acid). Spray with *anisaldehyde solution* and heat at 105° for 10 minutes. Both spots are bluish and between them a smaller bluish violet spot may be present.

**$\beta$ -Glycyrrhetic Acid**; 3 $\beta$ -Hydroxy-11-oxo-18 $\beta$ , 20 $\beta$ -olean-12-enoic Acid: C<sub>30</sub>H<sub>46</sub>O<sub>4</sub> = 470.69

General laboratory reagent grade of commerce.

mp, about 293°;  $[\alpha]_D^{20}$ , about +170° (1 per cent w/v in *chloroform*).

**Glyoxal Sodium Bisulphite**: C<sub>2</sub>H<sub>4</sub>Na<sub>2</sub>O<sub>8</sub>S<sub>2</sub>·H<sub>2</sub>O = 284.17

General laboratory reagent grade of commerce.

White or almost white, amorphous powder.

**Guaiphenesin**: Of the Indian Pharmacopoeia.

**Guanidine hydrochloride solution**: CH<sub>5</sub>N<sub>3</sub>·HCl = Mol. Wt. 95.1

Crystalline powder.

**Helium**: He = 4.003

Laboratory cylinder grade of commerce containing not less than 99.995 per cent v/v of He.

**Heparin**: See Heparin Sodium of the Indian Pharmacopoeia.

**Heparin Sodium**: Of the Indian Pharmacopoeia.

**Heptane**; *n*-Heptane: C<sub>7</sub>H<sub>16</sub> = 100.20

General laboratory reagent grade of commerce.

Clear, colourless, volatile, flammable liquid; bp, about 98°; wt. per ml, about 0.69 g.

**Hexadecanoic Acid**; Palmitic Acid: C<sub>16</sub>H<sub>32</sub>O<sub>2</sub> = 256.43

General laboratory reagent grade of commerce.

White, crystalline scales; mp, about 63°.

Complies with the following test.

**HOMOGENEITY** — Carry out test B for Identification described in the monograph for Chloramphenicol Palmitate applying to the plate 4 ml of a 0.2 per cent w/v solution in *acetone*. The chromatogram shows only one spot.

**Hexamine**; Hexamethylenetetramine: (CH<sub>2</sub>)<sub>6</sub>N<sub>4</sub> = 140.19

Analytical reagent grade of commerce.

Colourless crystals or crystalline powder; odourless.

**Hexane**; *n*-Hexane: C<sub>6</sub>H<sub>14</sub> = 86.18

Analytical reagent grade of commerce containing not less than 90 per cent of *n*-hexane.

Colourless, mobile, highly flammable liquid; bp, about 68°; wt. per ml, about 0.674 g.

**Hexane UV**: *Hexane* which complies with the following additional test.

**TRANSMITTANCE** — Not less than 97 per cent between 260 nm and 420 nm, using *water* as the blank.

**Hexanitrodiphenylamine**; Dipicrylamine: C<sub>12</sub>H<sub>5</sub>N<sub>7</sub>O<sub>12</sub> = 439.22

General laboratory reagent grade of commerce.

Yellow crystals moistened for safety with an equal weight of *water*; mp, about 243°, with explosive decomposition.

**Histamine Dihydrochloride**: C<sub>5</sub>H<sub>9</sub>N<sub>3</sub>·2HCl = 184.07

General laboratory reagent grade of commerce.

White, crystalline powder; mp, about 250°.

**Histamine Phosphate**: Of the Indian Pharmacopoeia.

**DL-Histidine Monohydrochloride**; Histidine Monohydrochloride: C<sub>6</sub>H<sub>9</sub>N<sub>3</sub>O<sub>2</sub>·HCl·H<sub>2</sub>O = 191.60

General reagent grade of commerce.

Colourless crystals or white, crystalline powder; mp, about 250°, with decomposition.

**Holmium Oxide**: Ho<sub>2</sub>O<sub>3</sub> = 377.86

General laboratory reagent grade of commerce.

Yellowish powder.

**Holmium Perchlorate Solution**: Laboratory reagent grade of commerce for the calibration of spectrophotometers. Consists of a 4 per cent w/v solution of *holmium oxide* in 1.4 M *perchloric acid*.

**Human Albumin**: Of the Indian Pharmacopoeia.

**Human Normal Immunoglobulin**: Of the Indian Pharmacopoeia.

**Hyaluronate Solution**: Dilute 1 volume of *sodium hyaluronate stock solution* with 1 volume of *phosphate-buffered saline*.

Use on the day of preparation.

**Hyaluronidase Solutions, Diluent for**: Mix 250 ml of *phosphate-buffered saline* with 250 ml of *water* and, within 2 hours before use, dissolves 330 mg of *hydrolysed gelatin* in the mixture.

**Hydrazine-molybdate Reagent**: Dissolve 0.1 g of *ammonium molybdate* in 10 ml of *water* containing 1.5 ml of *sulphuric acid*, dilute to about 90 ml with *water* and add 1 ml of a 0.15 per cent w/v solution of *hydrazine sulphate* and sufficient *water* to produce 100 ml.

**Hydrazine Reducing Mixture**; Reducing Mixture: Grind together 20 mg of *potassium bromide*, 5 g of *sodium chloride* and 0.5 g of *hydrazine sulphate* in the order stated to produce a homogeneous mixture.

**Hydrazine Sulphate:**  $\text{NH}_2\text{NH}_2 \cdot \text{H}_2\text{SO}_4 = 130.12$

Analytical reagent grade of commerce.

White, crystalline powder; mp, about  $254^\circ$ .

**Hydriodic Acid:** HI = 127.91

Analytical reagent grade of commerce.

Contains about 55 per cent w/w of HI; about 7.5 M in strength.

Colourless or almost colourless liquid when freshly prepared; rapidly becomes yellow or brown due to liberation of iodine; bp, about  $127^\circ$ ; wt. per ml, about 1.7 g.

**Hydrochloric Acid:** Of the Indian Pharmacopoeia.

About 11.5M in strength.

**Hydrochloric Acid AsT:** Hydrochloric acid, low in arsenic, commercially available.

**Hydrochloric Acid, x M:** Solutions of any molarity xM may be prepared by diluting 85x ml of *hydrochloric acid* to 1000 ml with *water*.

Store in containers of polyethylene or other non-reacting material at a temperature not exceeding  $30^\circ$ .

**Hydrochloric Acid AsT, Brominated:** Brominated hydrochloric acid low in arsenic, of commercial grade, or prepared by adding 1 ml of *bromine solution* to 100 ml of *hydrochloric acid*.

**Hydrochloric Acid, Dilute:** Of the Indian Pharmacopoeia. (Approximately 10 per cent w/w of *hydrochloric acid*).

**Hydrochloric Acid, Iron-Free:** *Hydrochloric acid* which complies with the following additional test.

Evaporate 5 ml on a water-bath nearly to dryness, add 40 ml of *water*, 2 ml of a 20 per cent w/v solution of *citric acid* and 2 drops of *thioglycollic acid*, mix, make alkaline with *dilute ammonia solution* and dilute to 50 ml with *water*; no pink colour is produced.

**Hydrochloric Acid, x M Methanolic:** Solutions of any molarity xM may be prepared by diluting 85x ml of *hydrochloric acid* to 1000 ml with *methanol*.

**Hydrochloric Acid AsT, Stannated:** Stannated hydrochloric acid, low in arsenic, of commercial grade, or prepared by adding 1 ml of *stannous chloride solution AsT* to 100 ml of *hydrochloric acid AsT*.

**Hydrocortisone:** Of the Indian Pharmacopoeia.

**Hydrocyanic Acid Solution:** A 0.3 per cent w/v solution of *hydrocyanic acid*. Standardise immediately before use.

**ASSAY** — To 50 ml in a flask containing 5 ml of 5 M *ammonia* add 0.25 ml of *dilute potassium iodide solution* and titrate with 0.1 M *silver nitrate* until permanent opalescence is produced.

1 ml of 0.1 M *silver nitrate* is equivalent to 0.005405 g of HCN.

**Hydrofluoric Acid:** HF = 20.01

Analytical reagent grade of commerce.

Colourless, corrosive liquid; odour, pungent; wt. per ml, about 1.13 g; contains not less than 40 per cent w/w of HF.

Store in polyethylene or gutta percha bottles.

**Hydrogen Peroxide Solution (100 vol):** Of the Indian Pharmacopoeia.

**Hydrogen Peroxide Solution (20 vol):** Of the Indian Pharmacopoeia.

**Hydrogen Peroxide Solution (10 vol):** Dilute Hydrogen Peroxide Solution: Dilute *hydrogen peroxide solution (20 vol)* with an equal volume of *water*.

Complies with the following test.

**CHLORIDE** — To 10 ml add 40 ml of *water*, 1 ml of *dilute nitric acid* and 1 ml of *silver nitrate solution*; no opalescence is produced.

Store as recommended under Hydrogen Peroxide Solution (100 vol).

**Hydrogen Sulphide:**  $\text{H}_2\text{S} = 34.08$

Use laboratory cylinder grade of commerce or prepare the gas by action of *hydrochloric acid*, diluted with an equal volume of *water*, on *iron sulphide*; wash the resulting gas by passing it through *water*.

Colourless, poisonous gas; odour, characteristic and unpleasant.

**Hydrogen Sulphide Solution:** A recently prepared saturated solution of *hydrogen sulphide* in *water*.

**Hydroquinone;** Quinol; 1,4-Dihydroxybenzene; Benzene-1,4-diol:  $\text{C}_6\text{H}_4(\text{OH})_2 = 110.11$

Analytical reagent grade of commerce.

Colourless or almost colourless crystals or crystalline powder; mp, about  $173^\circ$ .

Store protected from light and moisture.

**4-Hydroxybenzaldehyde:**  $\text{C}_7\text{H}_6\text{O}_2 = 122.12$

General laboratory reagent grade of commerce.

Colourless needles; mp, about  $118^\circ$ .

**4-Hydroxycoumarin:**  $\text{C}_9\text{H}_6\text{O}_3 = 162.14$

General laboratory reagent grade of commerce.

mp, about  $214^\circ$ .

**8-Hydroxy-7-iodoquinoline-5-sulphonic Acid:**

$\text{C}_9\text{H}_6\text{INO}_4\text{S} = 351.12$

General laboratory reagent grade of commerce.

Yellow, crystalline powder; almost odourless; mp, about  $265^\circ$ , with decomposition.



**Hydroxylamine Hydrochloride:** Hydroxylammonium Chloride:  $\text{NH}_2\text{OH}\cdot\text{HCl}$  = 69.49

Analytical reagent grade of commerce.

Colourless crystals of white, crystalline powder; slowly decomposes when moist; mp, about 151°.

**Hydroxylamine Hydrochloride Reagent:** Hydroxylamine Hydrochloride Reagent in Ethanol (60 per cent); Hydroxylamine Solution, Ethanolic (60 per cent); Hydroxylamine Solution, Ethanolic: Dissolve 34.75 g of *hydroxylamine hydrochloride* in 950 ml of *ethanol (60 per cent)*, add 5 ml of a 0.2 per cent w/v solution of *methyl orange* in *ethanol (60 per cent)* and then add 0.5 M *potassium hydroxide* in *ethanol (60 per cent)* until the full yellow colour is produced. Add sufficient *ethanol (60 per cent)* to produce 1000 ml.

Complies with the following test.

To 10 ml add one drop of 0.5 M *potassium hydroxide* in *ethanol (60 per cent)*; no change in colour produced. To a further 10 ml add 1 drop of 0.5 M *hydrochloric acid*; the colour changes slightly towards orange.

**Hydroxylamine Hydrochloride Solution:** Hydroxylamine Solution: Dissolve 1 g of *Hydroxylamine hydrochloride* in 50 ml of *water*, add 50 ml of *ethanol (95 per cent)* and 1 ml of *bromophenol blue solution* and then add 0.1 M *sodium hydroxide* until the solution becomes green.

**Hydroxylamine Hydrochloride Solution Sp.:** Dissolve 20 g of *hydroxylamine hydrochloride* in sufficient *water* to produce about 65 ml. Transfer to a separator, add 5 drops of *thymol blue solution* and *strong ammonia solution* until the solution becomes yellow. Add 10 ml of a 4 per cent w/v solution of *sodium diethyldithiocarbamate* and allow to stand for 5 minutes. Extract with successive quantities, each of 10 ml, of *chloroform* until a 5-ml portion of the extract does not acquire a yellow colour when shaken with *dilute cupric sulphate solution*. Add *dilute hydrochloric acid* until the solution is pink and then with sufficient *water* to produce 100 ml.

**Hydroxylamine Solution, Ethanolic (90 per cent):** Dissolve 7.0 g of *hydroxylamine hydrochloride* in 90 ml of *ethanol (90 per cent)*, warming gently if necessary, and add 1.6 ml of *dimethyl yellow solution* and sufficient 1 M *potassium hydroxide* in *ethanol (90 per cent)* to produce a pure yellow colour. Dilute to 100 ml with *ethanol (90 per cent)*.

**D-d-4-Hydroxyphenylglycine:**  $\text{C}_8\text{H}_9\text{NO}_3$  = 167.16

General laboratory reagent grade of commerce.

Shiny leaflets; mp, 220° to 247°, with decomposition.

**N-(p-Hydroxyphenyl)glycine;** *p*-Hydroxyphenyl-aminoacetic Acid; *p*-Hydroxycyanilinoacetic Acid; Photoglycine:  $\text{C}_8\text{H}_9\text{NO}_3$  = 167.16

Shiny leaflets from water; browns at 200°; mp, about 246°

**8-Hydroxyquinoline:** Quinolin-8-ol:  $\text{C}_9\text{H}_7\text{NO}$  = 145.16

Analytical reagent grade of commerce.

White to yellowish white, crystalline powder; mp about 74°.

**5-Hydroxyuracil:** Isobarbituric acid; Pyrimidine-2,4,5-triol; 2,4,5-Trihydroxypyrimidine:  $\text{C}_4\text{H}_4\text{N}_2\text{O}_3$  = 128.10

General laboratory reagent grade of commerce.

mp, about 310°, with decomposition.

**Hyoscine Hydrobromide:** Of the Indian pharmacopeia.

**Hyoscyamine Sulphate:**  $(\text{C}_{17}\text{H}_{23}\text{NO}_3)_2\cdot\text{H}_2\text{SO}_4\cdot 2\text{H}_2\text{O}$  = 712.82

General laboratory reagent grade of commerce.

mp, about 206°;  $[\alpha]_{\text{D}}^{20}$ , about -29° (2 per cent w/v in *water*).

**Hypophosphorus Acid:**  $\text{H}_3\text{PO}_2$  = 65.99

General laboratory reagent grade of commerce.

The water-free acid forms deliquescent crystals; supercools to a colourless, odourless, oily liquid; mp, about 265°.

**Hypophosphorus Acid, Dilute:** General laboratory reagent grade *hypophosphorus acid* of commerce diluted with *water* to contain about 10 per cent w/v of  $\text{H}_3\text{PO}_2$ .

Colourless liquid; wt. per ml, about 1.038 g.

**Hypophosphorus Reagent:** Dissolve, by heating gently, 10 g of *sodium hypophosphite* in 20 ml of *water* and dilute to 100 ml with *hydrochloric acid*. Allow to settle and decant or filter through glass wool.

**Iodoethane;** Ethyl Iodide:  $\text{C}_2\text{H}_5\text{I}$  = 155.97

General laboratory reagent grade of commerce.

Heavy, colourless liquid with ethereal odour, turning rapidly to yellowish brown; bp, about 72°, wt. per ml, about 1.94 g.

**Imidazole;** Glyoxaline:  $\text{C}_3\text{H}_4\text{N}_2$  = 68.08

Purified grade of commerce.

White, crystalline powder; mp, about 91°.

**Imidazole-Mercury Reagent:** Dissolve 8.25 g of *recrystallised imidazole* in 60 ml of *water* and add 10 ml of 5 M *hydrochloric acid*. Stir the solution magnetically and add, dropwise, 10 ml of a 0.27 per cent w/v solution of *mercuric chloride*. If a cloudy solution results, discard and prepare a further solution by adding the mercuric chloride solution more slowly. Adjust the pH to 6.75 to 6.85 with 5 M *hydrochloric acid* (about 4 ml is required) and add sufficient *water* to produce 100 ml.

**Imidazole, Recrystallised:** Recrystallise 25 g of *imidazole* twice from 100 ml of *toluene*, cooling in an ice-bath with stirring. Finally wash with *ether* and dry at room temperature at a pressure of 2kPa over *silica gel*, or use a purified grade of commerce.

Complies with the following test.

**LIGHT ABSORPTION** — When examined at about 325 nm (2.4.7), a 8 per cent w/v solution shows an absorption is not more than 0.10.

**Imidazole Solution:** Dissolve 8.25 g of *recrystallise imidazole* in 60 ml of *water*, adjust the pH to 6.75 to 6.85 with 5 M *hydrochloric acid* and add sufficient *water* to produce 100 ml.

The hydrochloric acid used in preparing this reagent must be free from stabilising mercury compounds.

**Iminodibenzyl:** 10,11-Dihydro-5H-dibenz[*b,f*]azepine: C<sub>14</sub>H<sub>13</sub>N = 195.26

General laboratory reagent grade of commerce.

Pale yellow, crystalline powder, mp, about 106°.

**Imipramine Hydrochloride:** Of the Indian Pharmacopoeia.

**Immunoglobulin, Normal Human:** Of the Indian pharmacopoeia.

**Indigo Carmine:** CI 73015; Sodium Indigotindisulphonate; Acid Blue 74: C<sub>16</sub>H<sub>8</sub>N<sub>2</sub>Na<sub>2</sub>O<sub>8</sub>S<sub>2</sub> = 466.40

General laboratory reagent grade of commerce.

Deep blue powder or blue granules with a coppery lustre.

**Indigo Carmine Solution:** To a mixture of 10 ml of *hydrochloric acid* and 990 ml of a 20 per cent w/v solution of *nitrogen-free sulphuric acid* in *water*, add sufficient *indigo carmine* (about 0.2 g) to produce a solution that complies with the following test.

Add 10 ml to a solution of 1.0 mg of *potassium nitrate* in 10 ml of *water*, rapidly add 20 ml of *nitrogen-free sulphuric acid* and heat to boiling; the blue colour is discharged within 1 minute.

**Industrial Methylated Spirit:** Of the Indian Pharmacopoeia.

**Iodine:** Of the Indian Pharmacopoeia.

**Iodine, x M:** Solutions of any molarity xM may be prepared in the following manner. Dissolve 400x g of *potassium iodide* in the minimum amount of *water*, add 260x g of *iodine*, allow to dissolve and add sufficient *water* to produce 1000 ml. Weaker solutions may be prepared using proportionately lesser amounts of reagents or by appropriate dilution.

**Iodine Bromide:** IBr = 206.81

General laboratory reagent grade of commerce.

Bluish or brownish black crystals with lachrymatory vapours; mp, about 40°; bp, about 116°.

Store protected from light in a cool place.

**CAUTION** — Iodine bromide vapours are corrosive to the eyes and mucous membranes.

**Iodine bromide solution:** Dissolve 20 g of *iodine bromide* in sufficient *glacial acetic acid* to produce 1000 ml.

Store protected from light and moisture.

**Iodine Monochloride solution:** Dissolve 8 g of *iodine trichloride* in about 200 ml of *glacial acetic acid* and separately dissolve 9 g of *iodine* in 300 ml of *dichloromethane*. Mix the two solutions and dilute to 1000 ml with *glacial acetic acid*.

Store in stoppered, light-resistant glass containers at a temperature not exceeding 15°.

**Iodine Pentoxide:** Recrystallised Iodine Pentoxide: I<sub>2</sub>O<sub>5</sub> = 333.84

General laboratory reagent grade of commerce recrystallised in the following manner. Boil a saturated solution of commercial iodine pentoxide in *nitric acid* for 1 hour and allow to stand for 24 hours. Decant the supernatant liquid and dry the crystals first in a current of air at room temperature and then over *phosphorus pentoxide* at a pressure not exceeding 0.7 kPa.

White or greyish white, crystalline and hygroscopic powder; contains not less than 99.5 per cent of I<sub>2</sub>O<sub>5</sub>.

**ASSAY** — Weigh accurately about 0.1 g, dissolve in 50 ml of *water*, add 3 g of *potassium iodide* and 10 ml of *dilute hydrochloric acid* and titrate the liberated iodine with 0.1 M *sodium thiosulphate using starch solution*, added towards the end of the titration, as indicator.

1 ml of 0.1 M *sodium thiosulphate* is equivalent to 0.002782 g of I<sub>2</sub>O<sub>5</sub>.

Store protected from light.

**Iodine Solution:** Dissolve 2.0 g of *iodine* and 3 g of *potassium iodide* in *water* to produce 100 ml.

**Iodine Trichloride:** ICl<sub>3</sub> = 233.26

Analytical reagent grade of commerce.

Reddish orange crystals; pungent irritating odour; volatile at room temperature; mp. about 33°.

Store in tightly-closed, light resistant glass containers preferably in a cool place.

**CAUTION** — Iodine Trichloride is corrosive to human skin.

**Iodoplatinate Reagent:** To 3 ml of a 10 per cent w/v solution of *chloroplatinic acid* add 97 ml of *water* and 100 ml of a 6 per cent w/v solution of *potassium iodide*.

Store protected from light.

**Iron Salicylate Solution:** Dissolve 0.1 g of *ferric ammonium sulphate* in 100 ml of *water* containing 2 ml of 1 M *sulphuric acid*, add 50 ml of a 1.15 per cent w/v solution of *sodium salicylate*, 10 ml of 2 M *acetic acid* and 80 ml of a 13.6 per cent w/v solution of *sodium acetate* and dilute to 500 ml with *water*.

The solution should be freshly prepared and stored in tightly-closed, light resistant containers.

**Isobutyl Acetate:**  $C_6H_{12}O_2 = 116.16$

General laboratory reagent grade of commerce.

Colourless liquid with a fruity odour; bp, about 118°; refractive index at 20°, about 1.391; wt. per ml, about 0.870 g

**Isobutyl alcohol:** 2-Methylpropanol; 2-Methyl-1-propanol; 2-Methylpropan-1-ol:  $(CH_3)_2CHCH_2OH = 74.12$

Analytical reagent grade of commerce.

Colourless liquid; odour, characteristic; bp, about 108°; wt. per ml, about 0.801 g.

**Isoniazid:** Of the Indian Pharmacopoeia.

**Isoniazid Solution:** Dissolve 0.1 g of *isoniazid* in 150 ml of *methanol* and add 0.12 ml of *hydrochloric acid* and sufficient *methanol* to produce 200 ml.

**Isopropylamine;** 2-Aminopropane; 2-Propylamine:  $CH_3CH(NH_2)CH_3 = 59.11$

Colourless, volatile, flammable liquid having a strong odour of ammonia; bp, about 32°; refractive index at 20°, 1.374 to 1.376; wt. per ml, about 0.69 g.

**Isopropyl Myristate:** Isopropyl Tetradecanoate with variable amounts of other fatty acid. isopropyl esters;  $C_{17}H_{34}O_2 = 270.45$

Clear, practically colourless oily liquid; odourless; refractive index at 20°, about 1.434.

Store protected from light and moisture.

**Karl Fischer Reagent:** Mix in a 750-ml combustion flask 400 ml of *dehydrated methanol* and 80 g of *dehydrated pyridine*. Immerse the flask in ice and bubble dried *sulphur dioxide* slowly through the mixture until its weight has increased by 20 g. Add 45 g of *iodine* and shake until it dissolves. Allow the solution to stand for 24 hours before use. This solution deteriorates gradually; therefore standardise it within 1 hour before use. Protect from light while in use. Store any bulk stock of the reagent in a suitably sealed, glass-stoppered container, fully protected from light and under refrigeration. A commercially available, stabilised solution of Karl Fischer reagent may be used.

*The reagent and the solutions used in the determination of water by the Karl Fischer method must be kept anhydrous and precautions must be taken throughout to prevent exposure to atmospheric moisture.*

**Kerosene:** Mixture of hydrocarbons, chiefly of the methane series, as available in commerce.

**Kieselghur:** Kieselghur, Acid-washed: A neutral diatomaceous earth, purified by treating with *dilute hydrochloric acid*, washing with *water* and drying.

**Kieselguhr for Column Chromatography:** *Kieselguhr* that complies with the following test.

**FILTRATION RATE** — Use a chromatography column (0.25 m × 10 mm) with a sintered-glass (100) plate and two marks at 0.10 m and 0.20 m above the plate. Place sufficient of the substance under examination in the column to reach the first mark and fill to the second mark with *water*. When the first drops begin to flow from the column, fill to the second mark again with *water* and measure the time required for the first 5 ml to flow from the column. The flow rate is not less than 1 ml per minute and the eluate obtained is colourless.

**Kieselguhr G:** consists of *Kieselguhr* treated with *hydrochloric acid* and calcined, to which is added about 15 per cent w/w of *calcium sulphate hemihydrate* ( $CaSO_4 \cdot 1/2H_2O$ ).

Fine, greyish white powder, the grey colour becomes more pronounced on triturating the product with *water*. The average particle size is between 10 mm and 40 mm.

Complies with the following tests.

**pH** — Shake 1 g for 5 minutes with 10 ml of *carbon dioxide-free water*. The pH of the suspension is between 7.0 and 8.0.

**SEPARATING POWER** — Determine by thin-layer chromatography (2.4.17), preparing plates using a slurry of the reagent under examination with 0.02 M *sodium acetate*.

*Mobile phase.* A mixture of 65 volumes of *ethyl acetate*, 23 volumes of *2-propanol* and 12 volumes of *water*.

*Test solution.* A 0.01 per cent w/v solutions in *pyridine* of *lactose*, *sucrose*, *dextrose*, *D-fructose*, *D-galactose*.

Apply separately to the plate 5 ml of each solution. Allow the mobile phase to rise 14 cm. The migration time of the solvent is about 40 minutes. Dry the plate and spray with about 10 ml of *anisaldehyde solution*, again dry at 105° for 10 minutes. The chromatogram shows five well-defined spots without tailing and well separated from each other.

**Kieselguhr H:** Fine, greyish white powder, the grey colour becomes more pronounced on triturating the product with *water*. The average particle size is between 10 mm and 40 mm.

Complies with the following tests.

**pH** — Shake 1 g for 5 minutes with 10 ml of *carbon dioxide-free water*. The pH of the suspension is between 6.4 and 8.0.

**SEPARATING POWER** — Complies with the test for SEPARATING POWER described under *Kieselguhr G*.

**Kovac's Reagent:** Dissolve 5 g of *4-dimethylamino-benzaldehyde* in 75 ml of *amyl alcohol* by warming on a water-bath at 50° to 55°, cool and add 25 ml of *hydrochloric acid*.

*Kovac's Reagent* should be light yellow to light brown in colour, and should be stored in light-resistant containers at a temperature between 2° and 10°.

**Lactose:** Of the Indian Pharmacopoeia.

**Lactophenol:** Dissolve 20 g of *phenol* in a mixture of 20 g of **lactic acid**, 40 g of *glycerin* and 20 ml of *water*.

**Lanthanum Nitrate:**  $\text{La}(\text{NO}_3)_3 \cdot 6\text{H}_2\text{O} = 433.02$

Atomic absorption spectroscopic grade of commerce.

Colourless crystals; deliquescent.

**Lanthanum Nitrate Solution:** A 5 per cent w/v solution of *lanthanum nitrate*.

**Lead Acetate;** Sugar of Lead:  $(\text{CH}_3\text{CO}_2)_2\text{Pb} \cdot 3\text{H}_2\text{O} = 379.33$

Analytical reagent grade of commerce.

Small, white, transparent, monoclinic prisms or heavy, crystalline masses; odour, acetous; taste, sweet and astringent; efflorescent in warm air; becomes basic when heated.

Store protected from moisture.

**Lead Acetate Cotton:** Immerse absorbent cotton in a mixture of 10 volumes of *lead acetate solution* and 1 volume of 2 M *acetic acid*. Drain off the excess of liquid by placing it on several layers of filter paper without squeezing the cotton. Allow to dry at room temperature.

Store protected from moisture.

**Lead Acetate Solution:** A 10.0 per cent w/v solution of *lead acetate* in *carbon dioxide-free water*.

**Lead Dioxide;** Lead oxide:  $\text{PbO}_2 = 239.20$

Analytical reagent grade of commerce.

Dark brown powder, evolves oxygen when heated, first forming  $\text{Pb}_3\text{O}_4$  and at high temperatures  $\text{PbO}$ .

**Lead Monoxide;** Litharge:  $\text{PbO} = 223.20$

Analytical reagent grade of commerce.

Pale orange, or pale brick red, heavy scales or powder; odourless.

**Lead Nitrate;** Lead (II) Nitrate:  $\text{Pb}(\text{NO}_3)_2 = 331.21$

Analytical reagent grade of commerce.

Colourless or white crystals or white, crystalline powder.

**Lead Nitrate Solution:** A 3.3 per cent w/v solution of *lead nitrate* in *water*.

**Lead Nitrate Stock Solution:** Dissolve 0.1598 g of *lead nitrate* in 100 ml of *water* to which has been added 1 ml of nitric acid, then dilute to 1000 ml with *water*.

Store in polyethylene or glass containers free from soluble lead salts.

**Lead Subacetate Solution:** Dissolve 40.0 g of *lead acetate* in 90 ml of *carbon dioxide-free water*. Adjust the pH to 7.5 with 10 M *sodium hydroxide*, centrifuge and use the clear,

supernatant solution. The solution remains clear when stored in a well-closed container.

**Lithium:**  $\text{Li} = 6.94$

General laboratory reagent grade of commerce.

A soft metal, the freshly cut surface of which is silvery grey. It reacts violently with *water* yielding hydrogen and a solution of lithium hydroxide. Before use, the paraffin oil in which the metal is supplied should be washed off with *toluene*.

Store under light paraffin or light petroleum.

**Lithium and Sodium Molybdotungstophosphate Solution:**

Dissolve 100 g of *sodium tungstate* and 25 g of *sodium molybdate* in 800 ml of *water* in a 1500-ml flask, add 50 ml of *phosphoric acid* and 100 ml of *hydrochloric acid* and heat under a reflux condenser for 10 hours. Cool, add 150 g of *lithium sulphate*, 50 ml of *water* and 0.25 ml of *bromine* and allow to stand for 2 hours. Remove the excess of bromine by boiling the mixture for 15 minutes without the condenser. Cool, filter and dilute to 1000 ml with *water*.

Store at a temperature not exceeding 4° and use not later than 4 months after preparation. It has a golden yellow colour and must not be used if any trace of green colour is visible.

**Lithium Chloride:**  $\text{LiCl} = 42.39$ .

Analytical reagent grade of commerce.

Deliquescent, cubic crystals, granular or crystalline powder; mp, about 613°.

**Lithium Hydroxide:**  $\text{LiOH} \cdot \text{H}_2\text{O} = 41.96$ .

Analytical reagent grade of commerce.

Store protected from moisture.

**Lithium Perchlorate:**  $\text{LiClO}_4 = 106.39$ .

General laboratory reagent grade of commerce.

Small, white crystals; mp, about 236°.

**Lithium Perchlorate, 0.1 M:** Dissolve 10.64 g of *lithium perchlorate* in sufficient *water* to produce 1000 ml.

**Lithium Sulphate:**  $\text{Li}_2\text{SO}_4 \cdot \text{H}_2\text{O} = 127.95$

Analytical grade of commerce.

Colourless crystals or white crystalline powder

**Magenta, Basic;** CI 42510; Fuchsin, Basic; Rosaniline Hydrochloride:  $\text{C}_{20}\text{H}_{19}\text{N}_3 \cdot \text{HCl} = 337.85$

Dark red powder or green crystals with a metallic lustre; soluble in *ethanol*; freely soluble in *water*; practically insoluble in *ether*.

Complies with the following test.

When used in the preparation of *decolorised magenta solution*, a nearly colourless solution is obtained.



**Magenta Reagent, Decolorised:** Fuchsin Reagent, Decolorised: To 1 g of *basic magenta* add 100 ml of *water*, heat to 50° and allow to cool, shaking occasionally. Allow to stand for 48 hours, shake and filter. To 4 ml of the filtrate add 6 ml of *hydrochloric acid*, mix and dilute to 100 ml with *water*. Allow to stand for at least 1 hour to ensure maximum fading.

**Magenta Solution, Decolorised;** Fuchsin Solution Decolorised: Dissolve 1 g of *basic magenta* in 600 ml of *water*, cool in an ice-bath and add 20 g of *sodium sulphite* dissolved in 100 ml of *water*. Cool in an ice-bath and add, slowly with constant stirring, 10 ml of *hydrochloric acid* and dilute with *water* to 1000 ml. If the resulting solution is turbid, it should be filtered and if brown in colour, it should be shaken with sufficient *decolorising charcoal* (0.2 to 0.3 g) to render it colourless and then filtered immediately. Occasionally it is necessary to add 2 to 3 ml of *hydrochloric acid*, followed by shaking, to remove the little residual pink colour. The solution resulting from any of the foregoing modifications should be allowed to stand overnight before use.

Store protected from light.

**Magnesium:** Mg = 24.31

General laboratory reagent grade of commerce.

Silvery-white ribbon, turnings, wire or grey powder.

**Magnesium Acetate:**  $(\text{CH}_3\text{COO})_2\text{Mg}\cdot 4\text{H}_2\text{O} = 214.45$

Analytical reagent grade of commerce.

Colourless crystals; deliquescent.

**Magnesium Chloride:**  $\text{MgCl}_2\cdot 6\text{H}_2\text{O} = 203.30$

Analytical reagent grade of commerce.

**Magnesium Nitrate:**  $\text{Mg}(\text{NO}_3)_2\cdot 6\text{H}_2\text{O} = 256.41$

Analytical reagent grade of commerce.

Colourless crystals; deliquescent.

**Magnesium Oxide, Heavy:** Of the Indian Pharmacopoeia.

**Magnesium Oxide, Light:** Of the Indian Pharmacopoeia.

**Magnesium Perchlorate:**  $\text{Mg}(\text{ClO}_4)_2 = 223.23$

White granules, very hygroscopic, granular or flaky powder.

Complies with the following tests.

**ACIDITY OR ALKALINITY** — Shake 2 g with 20 ml of *carbon dioxide-free water*; not more than 0.1 ml of either 0.1 M *hydrochloric acid* or 0.1 M *sodium hydroxide* is required for neutralisation.

**WATER** (2.3.43) — Not more than 14 per cent w/w.

**Magnesium Perchlorate, Anhydrous:**  $\text{Mg}(\text{ClO}_4)_2 = 223.21$

Analytical reagent grade of commerce.

**Magnesium Sulphate:** Of the Indian Pharmacopoeia.

**Magnesium Sulphate Solution, Ammoniacal:** Dissolve 10 g of *magnesium sulphate* and 20 g of *ammonium chloride* in 80 ml of *water* and add 42 ml of 5 M *ammonia*. Allow to stand for a few days in a well closed container, decant and filter.

**Magnesium Uranyl Acetate Solution:** Heat on a *water bath* 3.2 g of *uranyl acetate*, 10 g of *magnesium acetate*, 2 ml of *glacial acetic acid* and 30 ml of *water*. When the solution is complete allow to cool, add 50 ml of *ethanol* and dilute with *water* to 100 ml. Allow to stand for 24 hours and filter.

**Maleic acid;** (Z)-But-2-ene-1,4-dioic Acid:  $\text{C}_4\text{H}_4\text{O}_4 = 116.07$

General laboratory reagent grade of commerce.

Colourless crystals; mp, about 135°.

**Manganese Sulphate;** Manganese (II) sulphate:  $\text{MnSO}_4\cdot \text{H}_2\text{O} = 169.01$ .

Analytical reagent grade of commerce.

Pale red, slightly efflorescent crystals.

Complies with the following test.

**LOSS ON IGNITION** (2.4.20) — 10.0 to 12.0 per cent, determined on 1 g at 500°.

**Mannitol:** Of the Indian Pharmacopoeia.

**D- Mannose;** Mannose:  $\text{C}_6\text{H}_{12}\text{O}_6 = 180.16$ .

General laboratory reagent grade of commerce.

Colourless crystals or white crystalline powder; mp, about 132°, with decomposition;  $[\alpha]_D^{20}$  about +14.2° (20 per cent w/v in *water* containing about 0.05 per cent w/v of  $\text{NH}_3$ ).

**(±)- Menthol;** (±)-*p*-Methan-3-ol:  $\text{C}_{10}\text{H}_{20}\text{O} = 156.27$

General laboratory reagent grade of commerce.

Colourless, hexagonal crystals, usually needle-like or in fused masses or crystalline powder; odour, pleasant and peppermint-like; mp, about 34°.

**Menthyl Acetate:**  $\text{C}_{12}\text{H}_{22}\text{O}_2 = 198.31$

Analytical reagent grade of commerce.

Colourless liquid with a characteristic odour; wt. per ml, about 0.92 g.

**2-Mercaptoethanol:**  $\text{C}_2\text{H}_6\text{OS} = \text{Mol. Wt. } 78.1$

A liquid, miscible with *water*;  $d_4^{20}$  about 1.116; bp, about 157°.

**Mercuric Acetate;** Mercury (II) Acetate:  $(\text{CH}_3\text{COO})_2\text{Hg} = 318.68$ .

General laboratory reagent grade of commerce.

White Crystals or crystalline powder; odour, slightly acetic.

**Mercuric Acetate Solution:** A 5 per cent w/v solution of *mercuric acetate* in *glacial acetic acid*.

**Mercuric Bromide**; Mercury (II) Bromide:  $\text{HgBr}_2 = 360.40$

Analytical reagent grade of commerce.

White crystals or crystalline powder.

**Mercuric Bromide Solution, Ethanolic**: Dissolve 5 g *mercuric bromide* in 100 ml of *ethanol*, employing gentle heat to facilitate solution.

Store protected from light.

**Mercuric Chloride**; Mercury (II) Chloride:  $\text{HgCl}_2 = 271.50$

Analytical reagent grade of commerce.

Heavy, colourless or white, crystalline masses or crystalline powder.

**Mercuric Chloride, 0.2 M**: Dissolve 54.30 g of *mercuric chloride* in 250 ml of *dilute hydrochloric acid* and make the volume to 1000 ml with *water*.

Mercuric Chloride Solution: A 5 per cent w/v solution of mercuric chloride.

**Mercuric Nitrate**; Mercury (II) Nitrate;  $\text{Hg}(\text{NO}_3)_2 \cdot \text{H}_2\text{O} = 342.62$ .

Analytical reagent grade of commerce.

White or slightly yellow, deliquescent, crystalline powder with odour of nitric acid.

Store protected from light and moisture.

**Mercuric Nitrate Solution**; Millon's Reagent: Dissolve 3 ml of *mercury* in 27 ml of cold fuming *nitric acid* and dilute the solution with an equal volume of *water*.

Store protected from light and use within 2 months after preparation.

**Mercuric Oxide, Nitrogen-free**: Yellow mercuric oxide complies with the following additional test, but does not necessarily comply with the requirement for the content of HgO.

**NITROGEN** — Carry out the determination of nitrogen (2.3.30), using 0.3 g of the sample, 3 g of *anhydrous sodium sulphate*, 0.1 g of *dextrose* and 7 ml of *nitrogen-free sulphuric acid*. The difference between the titrations is not more than 0.1 ml of 0.05 M *sulphuric acid*.

**Mercuric Oxide, Yellow**; Yellow Mercury(II) Oxide:  $\text{HgO} = 216.59$

General laboratory reagent grade of commerce.

Orange-yellow, heavy, amorphous powder; odourless; stable in air but becomes discoloured on exposure to light.

Store protected from light and moisture.

**Mercuric Sulphate**; Mercury(II) Sulphate:  $\text{HgSO}_4 = 296.68$

General laboratory reagent grade of commerce.

White, odourless granules or crystalline powder; hydrolyses in *water*.

**Mercuric Sulphate Solution**: Mix 5 g of *yellow mercuric oxide* with 40 ml of *water*, add while stirring, 20 ml of *sulphuric acid* and 40 ml of *water*, and continue stirring until completely dissolved.

**Mercury**:  $\text{Hg} = 200.59$

Analytical reagent grade of commerce.

Shining, Silvery-white, heavy liquid, easily divisible into globules and extremely mobile; readily volatilises on heating; wt. per ml, about 13.5 g.

**Metaphosphoric Acid**:  $(\text{HPO}_3)_x$

General laboratory reagent grade of commerce.

Glassy lumps or sticks containing a proportion of sodium metaphosphate; hygroscopic.

Complies with the following tests.

**NITRATE** — Boil 1.0 g with 10 ml of *water*, cool, add 1 ml of *indigo carmine solution* and 10 ml of *nitrogen-free sulphuric acid* and heat to boiling; the blue colour is not entirely discharged.

**REDUCING SUBSTANCES** — Boil 1 g with 10 ml of *water* and add 0.1 ml of 0.1 M *potassium permanganate*; the pink colour is not entirely discharged.

**Metaphosphoric-Acetic Acids Solution**: Dissolve 15 g of *metaphosphoric acid* in 40 ml of *glacial acetic acid* and add *water* to produce 500 ml.

Store in a cool place and use within 2 days.

**Methanesulphonic Acid**:  $\text{CH}_3\text{O}_3\text{S} = 96.10$

General laboratory reagent grade of commerce.

Colourless, corrosive liquid; wt. per ml, about 1.48g.

**Methanesulphonic Acid, 2 M Methanolic**: Dissolve 192.2 g of *methanesulphonic acid* in sufficient *methanol* to produce 1000 ml.

**Methanol**; Methyl Alcohol:  $\text{CH}_3\text{OH} = 32.04$

Analytical reagent grade of commerce.

Clear, colourless liquid; odour, characteristic; bp, about 65°; wt. per ml, about 0.791 g.

When 'methanol' is followed by a percentage figure, an instruction to use *methanol* diluted with *water* to produce the specified percentage v/v of *methanol* is implied.

**Methanol, Acidified**: Mix 18 ml of *glacial acetic acid* and 900 ml of *methanol* and dilute to 1000 ml with *water*.

**Methanol, Aldehyde-free**: *Methanol* containing not more than 0.001 per cent of aldehydes and ketones. Dissolve 25 g of

*iodine* in 1000 ml of *methanol*. Add this solution, with constant stirring to 400 ml of 1 M *sodium hydroxide* and add 150 ml of *water*. Allow to stand for 16 hours, filter and boil under a reflux condenser until the odour of iodoform is no longer detectable. Distil the resulting solution by fractional distillation.

**Methanol, Anhydrous:** Methanol of commerce specially dried for use in Karl Fischer determinations and other non-aqueous titrations.

Complies with the following test.

**WATER** (2.3.43) — Not more than 0.03 per cent w/v.

**Methanol, Dehydrated:** *Methanol* which complies with the following additional test.

**WATER** (2.3.43) — Not more than 0.1 per cent w/w.

**2-Methoxyethanol;** Methoxyethanol; Ethylene Glycol Monomethyl Ether:  $C_3H_8O_2 = 76.10$

Chromatographic reagent grade of commerce.

Colourless liquid; bp, about 125°; wt. per ml, about 0.96 g.

**4-Methylaminophenol Sulphate;** Methylaminophenol Sulphate; Metol:  $(CH_3NHC_6H_4OH)_2 \cdot H_2SO_4 = 344.39$

General laboratory reagent grade of commerce.

White or cream coloured, crystalline powder becoming darker on exposure to air.

**Methylaminophenol with Sulphite Solution:** Dissolve 0.1 g of *4-methylaminophenol sulphate*, 20 g of *sodium metabisulphite* and 1 g of *sodium sulphite* in sufficient *water* to produce 100 ml.

**3-Methylbenzothiazolin-2-one Hydrazone Hydrochloride:**  $C_8H_9N_3S \cdot HCl \cdot H_2O = 233.72$

General laboratory reagent grade of commerce.

mp, about 277°.

When used for the determination of aldehydes, complies with the following test.

To 2 ml of *aldehyde-free methanol* add 60 ml of a 0.1 per cent w/v solution of *propionaldehyde* in *aldehyde-free methanol* and 5 ml of a 0.4 per cent w/v solution of the reagent under examination, mix and allow to stand for 30 minutes. Add 25 ml of a 0.2 per cent w/v solution of *ferric chloride hexahydrate*, dilute to 100 ml with *acetone* and mix. The absorbance of the resulting solution at about 660 nm is not less than 0.62. Use as the blank a solution prepared at the same time and in the same manner but omitting the propionaldehyde solution.

**Methylcellulose:** Of the Indian Pharmacopoeia.

**Methylcellulose (4000 cps):** Methylcellulose which complies with the following additional test.

**VISCOSITY** — Between 3000 and 5000 centipoises, determined by method B (2.4.28), on a solution prepared in the following

manner. Place 2.0 g, calculated with reference to the dried substance, in a wide-mouthed bottle, add 100 ml of *water* heated to about 90°, close the bottle with a stopper filtered with a stirrer and stir for 10 minutes. Place the bottle in an ice-bath and continue the stirring until a solution of uniform consistency is obtained. Remove from the ice-bath and allow the solution to attain room temperature. Express the results as dynamic viscosity in centipoises.

**Methyl *n*-Decanoate;** Methyl Caproate:  $C_{11}H_{22}O_2 = 186.29$

General laboratory reagent grade of commerce.

Colourless liquid; refractive index at 20°. about 1.425; wt. per ml, about 0.87 g.

Complies with the following additional test.

**RELATED SUBSTANCES** — Determine by gas chromatography (2.4.13).

*Test solution.* A 0.002 per cent w/v of the substance under examination in carbon *disulphide*.

*Reference solution.* A 0.2 per cent w/v of the reagent under examination in carbon *disulphide*.

Chromatographic system

- a glass column 1.5 m x 4 mm packed with silanised diatomaceous support (Diatomite CQ is suitable) (100 to 120 mesh) coated with 10 per cent w/w of silicone gum rubber (methyl) (SE-30 is suitable)
- Temperature: 150° and used in conjunction with a precolumn containing silanised glass wool.

The sum of the areas of any secondary peaks in the chromatogram obtained with the test solution is not greater than the area of the principal peak in the chromatogram obtained with reference solution.

***N*-Methylglucamine;** Meglumine:  $C_7H_{17}NO_3 = 195.22$

General laboratory reagent grade of commerce.

mp, about 129°.

**Methyl Laurate;** Methyl Dodecanoate:  $C_{13}H_{26}O_2 = 214.35$

General laboratory reagent grade of commerce containing not less than 98.0 per cent of  $C_{13}H_{26}O_2$ , determined by gas chromatography (2.4.13).

Colourless or pale yellow liquid; wt. per ml, about 0.87 g.

**Methyl Myristate;** Methyl Tetradecanoate:  $C_{15}H_{30}O_2 = 242.40$

General laboratory reagent grade of commerce containing not less than 98.0 per cent of  $C_{15}H_{30}O_2$ , determined by gas chromatography (2.4.13).

Colourless or slightly yellow liquid; wt. per ml, about 0.87 g.

**Methyl Palmitate;** Methyl Hexadecanoate:  $C_{17}H_{34}O_2 = 270.46$

General laboratory reagent grade of commerce containing not less than 98.0 per cent of  $C_{17}H_{34}O_2$ , determined by gas chromatography (2.4.13).

Colourless, waxy solid; fp, about 27°, wt. per ml at 30°, about 0.86 g.

**N-Methylpiperazine:** C<sub>5</sub>H<sub>12</sub>N<sub>2</sub> = 100.16

General laboratory reagent grade of commerce.

Colourless liquid; bp, about 138°; wt. per ml, about 0.90 g.

**Methyl Stearate:** C<sub>19</sub>H<sub>38</sub>O<sub>2</sub> = 298.51

General laboratory reagent grade of commerce containing not less than 98.0 per cent of C<sub>19</sub>H<sub>38</sub>O<sub>2</sub>, determined by gas chromatography (2.4.13).

White or pale yellow, crystalline solid; mp, about 38°.

**4,4'-Methylenebis-N,N-dimethylaniline;** Tetramethyldiaminophenylmethane: C<sub>17</sub>H<sub>22</sub>N<sub>2</sub> = 254.37

General laboratory reagent grade of commerce.

Lustrous leaflets; mp, about 88°.

**2-Methyl-5-nitroimidazole:** C<sub>4</sub>H<sub>5</sub>N<sub>3</sub>O<sub>2</sub> = 127.10

General laboratory reagent grade of commerce.

mp, about 253°.

**4-methylpentan-2-one;** 4-methyl-2-pentanone; Methyl Isobutyl Ketone: (CH<sub>3</sub>)<sub>2</sub>CHCH<sub>2</sub>COCH<sub>3</sub> = 100.16

Analytical reagent grade of commerce

Colourless liquid; bp, about 115°; wt. per ml, about 0.80 g.

**2-Methylpropan-2-ol;** 2-Methyl-2-propanol; *tert*-butyl Alcohol: C<sub>4</sub>H<sub>10</sub>O = 74.12

Analytical reagent grade of commerce.

Colourless, oily liquid or solid; odour, characteristic; mp, about 0.78 g.

**Molybdic oxide;** Molybdenum(VI) Oxide; Molybdenum Trioxide: MoO<sub>3</sub> = 143.94.

Analytical reagent grade of commerce

White or slightly yellow to slightly bluish powder or granules.

**Morphine Hydrochloride:** C<sub>17</sub>H<sub>19</sub>NO<sub>3</sub>·HCl·3H<sub>2</sub>O = 374.84

General laboratory reagent grade of commerce.

Colourless, glistening needles or white crystalline powder;

[α]<sub>D</sub><sup>20</sup>, about -112° (2 per cent w/v solution); contains not less than 98.0 per cent and not more than 101.0 per cent of C<sub>17</sub>H<sub>19</sub>NO<sub>3</sub>·HCl, calculated with reference to the dried substance.

**Naphthalene:** C<sub>10</sub>H<sub>8</sub> = 128.17

Commercial grade suitable for liquid scintillation.

White crystals; mp, about 81°.

**1,3-Naphthalenediol;** Naphthalene-1,3-diol; 1,3-dihydroxynaphthalene; Naphthorecorcinol: C<sub>10</sub>H<sub>8</sub>O<sub>2</sub> = 160.17

General laboratory reagent grade of commerce.

Colourless crystals; mp, about 124°.

**Naphthalene-2,7-diol;** 2,7-Dihydroxynaphthalene: C<sub>10</sub>H<sub>8</sub>O<sub>2</sub> = 160.17

General laboratory reagent grade of commerce.

mp, about 190°, with decomposition.

**Naphthalenediol Reagent;** Naphthalenediol Solution: Dissolve 10 mg of *naphthalene-2,7-diol* in 100 ml of *sulphuric acid* and allow to stand until the initial yellow colour has disappeared.

Use within 2 days.

**Naphthalenediol Reagent Solution:** Dissolve 2.5 mg of *naphthalene-2,7-diol* in 90 ml of *methanol* and 10 mg of *potassium ferricyanide* and 50 mg of *potassium cyanide* dissolved in 10 ml of *water*. Allow to stand for 30 minutes and add 100 ml of 0.05 M *sodium hydroxide*.

**1-Naphthol;** α-Naphthol: C<sub>10</sub>H<sub>7</sub>OH = 144.17

Analytical reagent grade of commerce.

Colourless or white crystals or white, crystalline powder; odour, phenolic; mp, about 95°.

Store protected from light.

**1-Naphthol Solution:** Dissolve 1 g of *1-naphthol* in a solution of 6 g of *sodium hydroxide* and 16 g of *anhydrous sodium carbonate* in 100 ml *water*.

Prepare immediately before use.

**1-Naphthol Solution, Dilute:** Dissolve 0.1 g of *1-naphthol* in 3 ml of a 15 per cent w/v solution of *sodium hydroxide* and dilute to 100 ml with *water*.

Prepare immediately before use.

**2-Naphthol;** β-Naphthol: C<sub>10</sub>H<sub>7</sub>OH = 144.17

Analytical reagent grade of commerce.

White leaflets or crystalline powder; odour, faint and resembling that of phenol; mp, about 122°.

Store protected from light.

**2-Naphthol Solution:** Dissolve 5 g of *2-naphthol*, freshly recrystallised, in 8 ml of *sodium hydroxide solution* and 20 ml of *water* and add sufficient *water* to produce 100 ml.

The solution must be freshly prepared.

**1-Naphthylamine;** α-Naphthylamine: C<sub>10</sub>H<sub>7</sub>NH<sub>2</sub> = 143.19

General laboratory reagent grade of commerce.

White or almost colourless crystals or powder, or crystalline lumps; becoming reddish on exposure to air; odour, unpleasant; mp, about 51°.

Store protected from light.



***N*-(1-Naphthyl)ethylenediamine Dihydrochloride**; *N*-(1-Naphthyl)ethane-1,2-diammonium Dichloride:  
 $\text{NH}_2\text{CH}_2\text{CH}_2\text{NH}(\text{C}_{10}\text{H}_7)_2\text{HCl} = 259.18$

General laboratory reagent grade of commerce which may contain *methanol* of crystallisation.

White or cream-coloured powder; mp, about 188°.

**Nickel Sulphate**; Nickel(II) Sulphate:  $\text{NiSO}_4 \cdot 7\text{H}_2\text{O} = 280.9$

Analytical reagent grade of commerce.

Green, crystalline powder or tetragonal crystals.

**Ninhydrin**; Indane-1,2,3-trione Hydrate:  $\text{C}_9\text{H}_4\text{O}_3 \cdot \text{H}_2\text{O} = 178.15$

Analytical reagent grade of commerce.

White or very pale yellow, crystalline powder; mp, about 255°.

Store protected from light.

**Ninhydrin and Stannous Chloride Reagent**; Ninhydrin-Stannous Chloride Solution: Dissolve 0.2 g of *ninhydrin* in 4 ml of hot *water* and add 5 ml of a 0.16 per cent w/v solution of *stannous chloride*. Allow the mixture to stand for 30 minutes, filter and store at 2° to 8°. Dilute 2.5 ml of the solution with 5 ml of *water* and 45 ml of *2-propanol* immediately before use.

The reagent must be freshly prepared.

**Ninhydrin Reagent**: Dissolve 4 g of *ninhydrin* in 100 ml of *2-methoxyethanol*, shake gently with 1 g of a cation exchange resin (hydrogen form) (Dowex 50 is suitable) and filter. Add this solution to 100 ml of a 0.16 per cent w/v solution of *stannous chloride* in *acetate buffer pH 5.5*, immediately before use.

The reagent must be freshly prepared.

**Ninhydrin Solution**: A 0.2 per cent w/v solution of *ninhydrin* in a mixture of 95 volumes of *1-butanol* and 5 volumes of *2 M acetic acid*.

**Ninhydrin Solution, Ethanolic**: Dissolve 0.1 g of *ninhydrin* in 50 ml of *ethanol (95 per cent)* and add 10 ml of *glacial acetic acid*.

**Nitranilic Acid**; 2,5-Dihydroxy-3,6-dinitro-1,4-benzoquinone:  
 $\text{C}_6\text{H}_2\text{N}_2\text{O}_4 \cdot 2\text{H}_2\text{O} = 266.41$

General laboratory reagent grade of commerce.

Orange or orange-yellow, crystalline powder.

**Nitranilic Acid Solution**: A 3.5 per cent w/v of *nitranilic acid* in *ethanol (95 per cent)*.

**Nitric Acid**:  $\text{HNO}_3 = 63.01$ .

Clear, Colourless, fuming liquid; corrosive; about 16 M in strength; wt. per ml, about 1.42 g; contains about 70 per cent w/w of  $\text{HNO}_3$ .

Store protected from light.

**Nitric Acid, x M**: Solutions of any molarity xM may be prepared by diluting 63x ml of *nitric acid* to 1000 ml with *water*.

**Nitric Acid, Dilute**: Contains approximately 10 per cent w/w of  $\text{HNO}_3$ . Dilute 106 ml of *nitric acid* to 1000 ml with *water*.

**Nitric Acid, Fuming**:  $\text{HNO}_3 = 63.01$

Analytical reagent grade of commerce.

Clear, almost colourless to yellow, fuming liquid; corrosive; about 22.5 M in strength; wt. per ml, about 1.5 g; contains about 95 per cent w/w of  $\text{HNO}_3$ .

Store protected from light.

**Nitric Oxide**:  $\text{NO} = 30.01$

Nitric oxide, washed with *water*.

**4-Nitroaniline**; *p*-Nitroaniline:  $\text{NO}_2\text{C}_6\text{H}_4\text{NH}_2 = 138.13$

Microanalytical reagent grade of commerce.

Deep yellow, crystalline powder; mp, about 148°.

**Nitroaniline Solution, Diazotised**: Dissolve 0.4 g of *4-nitroaniline* in 60 ml of *1 M hydrochloric acid*, Cool to 15° and add a 10 per cent w/v solution of *sodium nitrite* in *water* until one drop of the mixture turns *starch iodide paper* blue.

Prepare immediately before use.

**2-Nitrobenzaldehyde**; *o*-Nitrobenzaldehyde:  $\text{NO}_2\text{C}_6\text{H}_4\text{CHO} = 151.12$

General laboratory grade reagent of commerce.

Yellow needles; odour, almond-like; mp, about 43°.

**Nitrobenzene**:  $\text{C}_6\text{H}_5\text{NO}_2 = 123.11$

Analytical reagent grade of commerce.

Pale yellow liquid; odour, characteristic; bp, about 211°; wt. per ml, about 1.20 g.

**4-Nitrobenzoyl Chloride**; *p*-Nitrobenzoyl Chloride  
 $\text{NO}_2\text{C}_6\text{H}_4\text{COCl} = 185.57$

Analytical reagent grade of commerce.

Yellow crystals or crystalline masses; odour, pungent; decomposes in moist air; mp, about 73°.

**4-Nitrobenzyl Bromide**; *p*-Nitrobenzyl Bromide:  
 $\text{NO}_2\text{C}_6\text{H}_4\text{CH}_2\text{Br} = 216.03$

General laboratory reagent grade of commerce.

Pale yellow crystals with a lachrymatory vapour; mp, about 99°.

**4-Nitrobenzyl Chloride**; *p*-Nitrobenzyl Chloride:  
 $\text{NO}_2\text{C}_6\text{H}_4\text{CH}_2\text{Cl} = 171.58$

General laboratory reagent grade of commerce.

Pale yellow crystals with a lachrymatory vapour; mp, about 72°.

**4-Nitrobenzyl Chloride Solution:** A 4.5 per cent w/v solution of 4-nitrobenzyl chloride in ethanol.

**4-(4-Nitrobenzyl)pyridine:**  $C_{12}H_{10}N_2O_2 = 214.22$

General laboratory reagent grade of commerce.

Pale yellow, crystalline powder; mp about 70°.

**Nitrogen:**  $N_2 = 28.01$

Laboratory cylinder grade of commerce, washed with water and dried.

**Nitrogen for Chromatography:** Nitrogen containing not less than 99.95 per cent v/v of  $N_2$ .

**Nitrogen, Oxygen-free:** Nitrogen that has been freed from oxygen by passage through alkaline pyrogallol solution.

**Nitromethane:**  $CH_3NO_2 = 61.04$

General laboratory reagent grade of commerce.

Colourless, oily liquid; odour, strong and somewhat disagreeable; bp, about 101°; wt. per ml, about 1.13 g.

*CAUTION* — Nitromethane forms explosive compounds with amines and strong bases.

**4-Nitrophenyl Disodium Phosphate:** 4-Nitrophenyl Disodium Orthophosphate:  $NO_2C_6H_4Na_2PO_4 \cdot 6H_2O = 371.14$

Analytical reagent grade of commerce.

White crystals.

Complies with the following test.

**INORGANIC PHOSPHATE** — Dissolve 10 mg in sufficient water to produce 100 ml, add 4 ml of sulphomolybdic acid solution, shake and add 0.1 ml of dilute stannous chloride solution. Allow to stand for 10 minutes. Any blue colour produced is not more intense than that produced in a solution prepared at the same time and in the same manner but using 6.1 ml of phosphate standard solution (5 ppm  $PO_4$ ) in place of the reagent under examination. Compare 20 ml of each solution.

**Nitrophenyl Phosphate Solution:** Dissolve 4.08 g of 4-nitrophenyl disodium phosphate in sufficient diethanolamine buffer pH 10.0 to produce 100 ml.

Store at 4° and use within 24 hours.

**Nitroso R Salt;** 1-Nitroso-2-naphthol-3,6-disulphonic Acid Disodium Salt:  $C_{10}H_5NNa_2O_8S_2 = 377.27$

General laboratory reagent grade of commerce.

Yellow powder.

**Nitrous Oxide:** Of the Indian Pharmacopoeia.

**Nonadecanoic Acid:**  $C_{19}H_{38}O_2 = 298.50$

General laboratory reagent grade of commerce.

mp, about 69°.

**Nonan-5-one;** Di-*n*-butyl Ketone:  $CH_3(CH_2)_3CO(CH_2)_3CH_3 = 142.24$

Analytical reagent grade of commerce.

bp, about 188°; wt. per ml, about 0.83 g.

**Noradrenaline Acid Tartrate:** Of the Indian Pharmacopoeia.

**Normal Serum Reagent:** Collect normal human blood in a dry, sterile glass bottle, incubate at 37° for 3 hours, maintain at 4° overnight, remove the serum, dry from the frozen state and keep in a vacuum desiccator over phosphorus pentoxide. Dissolve a quantity of the dried serum calculated to have been obtained from 1 ml of the serum in sufficient imidazole buffer pH 7.4 to produce 10 ml and allow to stand at 4° for 24 to 36 hours.

**Noscapine Hydrochloride:**  $C_{22}H_{23}NO_7 \cdot HCl \cdot H_2O = 467.91$

General laboratory reagent grade of commerce.

Colourless crystals or white, crystalline powder; mp, about 200°, with decomposition; hygroscopic; contains not less than 98.5 per cent and not more than 100.5 per cent of  $C_{22}H_{23}NO_7 \cdot HCl \cdot H_2O$  calculated with reference to the dried substance.

**Octanoic Acid;** Caprylic Acid:  $C_8H_{16}O_2 = 144.21$

General laboratory reagent grade of commerce.

Colourless, oily liquid; bp, about 237°; wt. per ml, about 0.92 g.

**2-Octanol;** Octan-2-ol; *sec*-Octyl Alcohol:  $C_8H_{18}O = 130.23$

General laboratory reagent grade of commerce.

Oily liquid; bp, about 178°; wt. per ml, about 0.82 g.

**Octoxinol;** Octoxylenol 9; Polyethylene Glycol Mono-(octylphenyl) ether:  $C_{34}H_{62}O_{11}$  (average) = 646.86 (average)

Clear, pale yellow, viscous liquid; odour faint; hydroxyl value, between 85 and 101.

**Octoxinol 10;**  $\alpha$ -[4-(1,1,3,3-Tetramethylbutyl)phenyl]- $\omega$ -hydroxypoly(oxyethylene): General laboratory reagent grade of commerce (Triton X-100 is suitable).

Clear, pale yellow, viscous liquid.

Store protected from moisture.

**Octylamine:** *n*-Octylamine; 1-Amino-octane:  $C_8H_{19}N = 129.3$

General reagent grade of commerce.

**(4-*tert*-Octylphenoxy)nonaethoxyethanol:**

(*p-tert*-octyl-phenoxy)nonaethoxyethanol;  $C_{34}H_{62}O_{11} = 646.86$

General laboratory reagent grade of commerce.

**Oestradiol Benzoate:** Of the Indian Pharmacopoeia.

**Orcinol;** 5-Methylresorcinol:  $C_7H_8O_2 \cdot H_2O = 142.15$

General laboratory reagent grade of commerce.

White to light tan crystals; mp, about 60°.

**Osmic Acid**; Osmium Tetroxide:  $\text{OsO}_4 = 254.20$ .

General laboratory reagent grade of commerce.

White or light yellow needles or a yellow crystalline mass or very deliquescent crystalline powder; mp, about  $40^\circ$ .

**Osmic Acid Solution**: General laboratory reagent grade of commerce consisting of a 1 per cent w/v solution of *osmic acid* in *water*.

**CAUTION** — *Osmic acid solution is corrosive to the eyes, mucous membranes and skin.*

**Oxalic Acid**:  $(\text{COOH})_2 \cdot 2\text{H}_2\text{O} = 126.07$

Analytical reagent grade of commerce.

Colourless Crystals.

**Oxalic Acid and Sulphuric Acid**; Oxalic Acid- Sulphuric Acid Reagent: A 5 per cent w/v solution of *oxalic acid* in cold *sulphuric acid* (50 per cent).

**Ox Brain, Acetone-Dried**: Cut into small pieces a fresh ox brain previously freed from vascular and connective tissue. Place in *acetone* for preliminary dehydration. Complete the dehydration by pounding in a mortar 30 g of this material with successive quantities, each of 75 ml, of *acetone* until a dry powder remains after filtration. Finally dry at  $37^\circ$  for 2 hours until all traces of acetone are removed.

**Oxygen**: Of the Indian Pharmacopoeia.

**Oxytocin**: Of the Indian Pharmacopoeia.

**Palladium Chloride**; Palladous Chloride:  $\text{PdCl}_2 = 177.33$

General laboratory reagent grade of commerce.

Brownish red powder; hygroscopic; contains not less than 59.3 per cent of Pd.

**Papaverine Hydrochloride**:  $\text{C}_{20}\text{H}_{21}\text{NO}_4\text{HCl} = 375.85$

General laboratory reagent grade of commerce.

White or almost white crystals or crystalline powder.

**Paracetamol**: Of the Indian Pharmacopoeia.

**Paracetamol, 4-Aminophenol-free**: *Paracetamol* that has been recrystallised from *water* and dried at a pressure of 2 kPa at  $70^\circ$ . If necessary, repeat the procedure until it complies with the following test.

Dissolve 5 g of the dried material in sufficient *methanol* (50 per cent) to produce 100 ml, add 1 ml of freshly prepared *sodium nitroprusside-carbonate solution*, mix and allow to stand for 30 minutes protected from light; no blue or green colour is produced.

**Paraffin, Light Liquid**: Of the Indian Pharmacopoeia.

**Paraffin, Liquid**: Of the Indian Pharmacopoeia.

**Pararosaniline Hydrochloride**; CI 42500; Pararosaniline Chloride; Basic Red 9;  $\text{C}_{19}\text{H}_{18}\text{ClN}_3 = 323.82$

General laboratory reagent grade of commerce.

Bluish red, crystalline powder; mp, about  $270^\circ$ , with decomposition.

**Pararosaniline Solution, Decolorised**: To 0.1 g of *pararosaniline hydrochloride* add 60 ml of *water* and a solution of 0.1 g of anhydrous *sodium sulphite* or 2.0 g of *sodium sulphite* or 0.75 g of *sodium metabisulphite* in 10 ml of *water*. Add slowly, with stirring, 6 ml of 2 M *hydrochloric acid*, stopper the flask and continue stirring until completely dissolved. Dilute to 100 ml with *water*. Allow to stand for 12 hours before use.

Store protected from light.

**Penicillinase Solution**: Dissolve 10 g of *casein hydrolysate*, 2.72 g of *potassium dihydrogen phosphate* and 5.88 g of *sodium citrate* in 200 ml of *water*, adjust the pH to 7.2 with *sodium hydroxide solution* and dilute to 1000 ml with *water*. Dissolve 0.41 g of *magnesium sulphate* in 5 ml of *water* and add 1 ml of a 0.15 per cent w/v solution of *ferrous ammonium sulphate* and sufficient *water* to produce 10 ml. Sterilise both solutions by heating in an autoclave, cool, mix, distribute in shallow layers in conical flasks and inoculate with *Bacillus cereus* (NCTC 9946). Incubate the flasks at  $18^\circ$  to  $37^\circ$  until the growth is observed and then maintain at  $35^\circ$  to  $37^\circ$  for 16 hours, agitating constantly to ensure maximum aeration. Centrifuge and sterilise the supernatant fluid by filtration through a suitable membrane filter.

1.0 ml of Penicillinase Solution will destroy penicillin activity at the rate of at least one million Units per hour at  $30^\circ$  and pH 7.0. Proportionately more is needed to destroy the activity in concentrations of 1000 Units per ml or less. To ensure complete destruction, it is advisable to use 10 times the quantity of penicillinase solution indicated above.

Complies with the tests for sterility (2.2.11).

Store at  $0^\circ$  to  $2^\circ$  and use within 2 to 3 days: When freeze-dried and kept in sealed ampoules, it may be stored for several months.

**1-Pentane**; *n*-Pentane:  $\text{CH}_3(\text{CH}_2)_3\text{CH}_3 = 72.15$

General laboratory reagent grade of commerce.

Clear, colourless, highly flammable, volatile liquid; bp, about  $36^\circ$ ; refractive index at  $20^\circ$ , about 1.359; wt. per ml, about 0.63 g.

*1-Pentane* intended for use in spectrophotometry complies with the following additional test.

**TRANSMITTANCE** — Not less than 20 per cent at about 200 nm, 50 per cent at about 210 nm, 85 per cent at about 220 nm, 93 per cent at about 230 nm and 98 per cent at about 240 nm, determined using *water* as the blank.

**1-Pentanol**; Pentan-1-ol; *n*-Pentyl Alcohol:  $\text{C}_5\text{H}_{12}\text{O} = 88.15$

General laboratory reagent grade of commerce.

Colourless liquid; bp, about 137°; wt. per ml, about 0.81g.

**Pepsin:** Of the Indian Pharmacopoeia.

**Perchloric Acid:**  $\text{HClO}_4 = 100.46$

Analytical reagent grade of commerce.

A solution in *water* containing between 70 per cent and 72 per cent w/v of  $\text{HClO}_4$  and about 12 M in strength.

Clear, colourless liquid; very corrosive and may deflagrate on contact with oxidisable substances; wt. per ml, about 1.7 g.

**Perchloric Acid, x M:** Solutions of any molarity xM may be prepared by diluting 82x ml of *perchloric acid* to 1000 ml with *water*.

**Perchloric Acid, 60 per cent:**

Analytical reagent grade of commerce.

A solution in *water* containing between 60.0 and 62.0 per cent w/w of  $\text{HClO}_4$  and about 9 M in strength.

Clear Colourless liquid.

**Periodic Acid Reagent:** Dissolve 0.5 g of *sodium periodate* in 5 ml of *water*, add 1 ml of 2 M *sulphuric acid* and dilute to 10 ml with *water*.

Prepare immediately before use.

**Periodic-Acetic Acids Solution:** Dissolve 0.446 g of *sodium periodate* in 2.5 ml of *sulphuric acid (25 per cent)* and dilute with *glacial acetic acid* to 100 ml.

**Peroxyacetic Acid Solution:** Dilute 1 ml of *hydrogen peroxide (100 vol)* to 100 ml with *glacial acetic acid*. Mix and allow to stand for 12 hours before use.

Use within 24 hours after preparation.

**Petroleum, Light;** Petroleum Spirit; Petroleum Ether: Analytical reagent grade of commerce.

Colourless, very volatile, highly flammable liquids obtained from petroleum, consisting of a mixture of the lower members of the paraffin series of hydrocarbons and having wt. per ml indicate against each.

Boiling range	Wt. per ml (approx.)
30° to 40°	0.63 g
40° to 60°	0.64 g
50° to 70°	0.66 g
60° to 80°	0.67 g
80° to 100°	0.70 g
100° to 120°	0.72 g
120° to 160°	0.75 g

**Phenacetin;** *p*-Ethoxyacetanilide:  $\text{C}_{10}\text{H}_{13}\text{NO}_2 = 179.22$

General laboratory reagent grade of commerce.

White, glistening crystalline scales or crystalline powder; odourless; mp, about 135°.

**1,10-Phenanthroline;** *o*-phenanthroline:  $\text{C}_{12}\text{H}_8\text{N}_2, \text{H}_2\text{O} = 198.22$

Analytical reagent grade of commerce.

White to cream-coloured crystals or crystalline powder; mp, about 100°.

**Phenanthroline Solution:** Dissolve 1.5 g of *1,10-phenanthroline* in sufficient *water* to produce 100 ml.

**Phenazone;** 2,3-Dimethyl-1-phenyl-3-pyrazolin-5-one:  $\text{C}_{11}\text{H}_{12}\text{N}_2\text{O} = 188.23$

General laboratory reagent grade of commerce.

Colourless crystalline powder; mp, about 112°.

**Phenobarbitone:** Of the Indian Pharmacopoeia.

**Phenol:** Of the Indian Pharmacopoeia.

**Phenol, Liquified:** General laboratory reagent grade of commerce consisting of a solution of *phenol* in *water* containing about 80 per cent w/w of  $\text{C}_6\text{H}_6\text{O}$ . Colourless liquid which may acquire a pinkish blue colour on keeping; odour, characteristic and somewhat aromatic; caustic; wt. per ml, about 1.055 g.

**Phenol Reagent;** Folin and Ciocalteu Phenol Reagent: Readymade reagent commercially available or may be prepared in the following manner.

Dissolve 100 g of *sodium tungstate* and 25 g of *sodium molybdate* in 800 ml of *water* in a 1500-ml flask, add 50 ml of *phosphoric acid* and 100 ml of *hydrochloric acid* and reflux for 10 hours, cool, add 150 g of *lithium sulphate*, 50 ml of *water*, add 4 to 6 drops of *bromine* and allow to stand for 2 hours. Boil for 15 minutes, cool, filter. The reagent should have no greenish tint. Protect from dust. Dilute a portion with an equal volume of *water* before use.

**Phenol Solution:** A saturated solution of phenol in *water*.

**Phenol Saline Solution:** A solution containing 0.5 per cent w/v of *phenol*, 0.85 per cent of *sodium chloride* and 2 per cent of *sodium hydroxide* in *water*.

**Phenoldisulphonic Acid Solution:** A clear liquid which may develop a pale brown colour on storage, prepared either by heating 3 g of *phenol* with 20 ml of *sulphuric acid* on a water-bath for 6 hours and transferring the resulting liquid to a stoppered vessel, or by diluting a 25 per cent w/v solution of commerce with *sulphuric acid* to contain 15 per cent w/v of phenol. The solution complies with the following test.

**SENSITIVITY TO NITRATE** — Evaporate a solution containing 0.1 mg of *potassium nitrate* to dryness in a porcelain dish on a water-bath. To the cooled residue add 1 ml of the reagent and allow to stand for 10 minutes. Add 10 ml of *water*, cool,



add 10 ml of 5 *M ammonia* and dilute to 25 ml with *water*. A distinct yellow colour is produced when compared with a solution prepared in the same manner but omitting the potassium nitrate.

**Phenoxyacetic Acid; 2-Phenoxyethanoic Acid:**  
 $C_6H_5OCH_2COOH = 152.14$

General laboratory reagent grade of commerce.

White or almost white crystals; mp, about 98°.

Complies with the following test.

**HOMOGENEITY** — Examine under the conditions and at the concentration prescribed in the test for Phenoxyacetic acid described in the monograph for Phenoxyethylpenicillin Potassium applying to the plate 10 mg of a 10 per cent w/v solution in *methanol* (50 per cent). The chromatogram shows only one spot.

**Phenoxybenzamine Hydrochloride; (RS)-(2-Benzylchloroethyl)-1-methyl-2-phenoxyethylamine Hydrochloride:**  
 $C_{18}H_{22}ClNO, HCl = 340.29$

General laboratory reagent grade of commerce.

White or almost white crystalline powder, odourless or almost odourless; mp, about 139°.

**2-Phenoxyethanol; Phenoxyethanol:**  $C_6H_5OCH_2OH = 138.17$

General laboratory reagent grade of commerce.

Clear, colourless, slightly viscous oily liquid; refractive index at 20°, about 1.537; fp, not less than 12°; wt. per ml, about 1.11 g.

**(E)-4-Phenyl-3-buten-2-one; (E)-4-Phenylbut-3-en-2-one;**  
 Benzalacetone:  $C_{10}H_{10}O = 146.19$

General laboratory reagent grade of commerce.

Lustrous plates; coumarin type odour; mp, about 41°.

**4-Phenylenediamine Dihydrochloride;**  
*p*-Phenylenediammonium Dichloride:  $C_6H_8N_2, 2HCl = 181.08$

General laboratory reagent grade of commerce.

White to pale tan crystals, or crystalline powder, turning pink on exposure to air.

Store protected from light and moisture.

**Phenylhydrazine:**  $C_6H_5NHNH_2 = 108.14$

General laboratory reagent grade of commerce.

Colourless or yellowish liquid, turning yellow or dark red on exposure to light and air; fp, not less than 18°; bp, about 241°, with some decomposition.

Store protected from light and moisture. It should be freshly distilled under reduced pressure before use.

**Phenylhydrazine Hydrochloride;** Phenylhydrazinium Chloride:  $C_6H_5NHNH_2HCl = 144.60$

Analytical reagent grade of commerce.

White or almost white, crystalline powder, turning brown on exposure to air particularly if exposed to bright light; mp, about 245°, with decomposition.

Store protected from light.

**Phenylhydrazine Solution:** Phenylhydrazine Hydrochloride Solution; Phenylhydrazine-Sulphuric Acid Solution; Dissolve 65 mg of *phenylhydrazine hydrochloride*, previously recrystallised from *ethanol* (85 per cent), in sufficient of a mixture of 170 ml of *sulphuric acid* and 80 ml of *water* to produce 250 ml.

Prepare immediately before use.

**Phenylmethyl Silicone Fluid (50 per cent Phenyl):**  
 Chromatographic reagent grade of commerce.

**Phloroglucinol;** Benzene-1,3,5-triol; 1,3,5-Trihydroxybenzene:  
 $C_6H_3(OH)_3, 2H_2 = 162.14$

Analytical reagent grade of commerce.

White or yellowish crystals or crystalline powder; mp, about 220°.

**Phosphatase Enzyme, Alkaline:** A suitable enzyme reagent grade of commerce.

**Phosphatase Solution, Alkaline:** Transfer 3.1 g of *boric acid* to a 1000 ml volumetric flask containing 500 ml of *water*, add 21 ml of 1 *M sodium hydroxide* and 10 ml of a 2.0 per cent w/v solution of *magnesium chloride*, dilute to volume with *water* and mix. Adjust the pH of the solution to  $9.0 \pm 0.2$  by addition of 1 *M sodium hydroxide* or 1 *M hydrochloric acid*, as necessary (solution A).

Dissolve 0.1 g of *alkaline phosphatase enzyme* in 40 ml of solution A in a 50 ml volumetric flask, dilute to volume with solution A and mix. Prepare the solution fresh daily.

**Phospholipid:** Wash a quantity of normal human or bovine brain freed from meninges and blood vessels and macerate in a suitable blender. Weigh 1000 to 1300 g of the macerate and measure its volume (V ml). Extract with three quantities, each of 4V ml of *acetone*, filter by suction and dry the precipitate at 37° for 18 hours. Extract the dry precipitate with 2 quantities, each of 2V ml, of the mixture of 2 volumes of *light petroleum* (boiling range 30° to 40°) and 3 volumes of *light petroleum* (boiling range 40° to 60°), filtering each extract through a filter paper previously washed with the light petroleum mixture. Combine the extracts and evaporate to dryness at 45° at a pressure not exceeding 0.7 kPa. Dissolve the residue in 0.2V ml of *ether* and allow to stand at 4° until a deposit is produced. Centrifuge and evaporate the clear supernatant liquid under reduced pressure until the volume is reduced to about 100 ml per kg of the original macerate. Allow to stand at 4° until a precipitate is produced (12 to 24 hours) and centrifuge. To the

clear supernatant liquid add 5 volumes of *acetone*, centrifuge, discard the supernatant liquid, dry the precipitate and store protected from light in a vacuum desiccator.

**Phosphomolybdic Acid:** Dodecamolybdophosphoric Acid: Approximately  $\text{H}_3\text{PO}_4, 12\text{MoO}_3, 24\text{H}_2\text{O} = 2257.65$

Analytical reagent grade of commerce.

Fine, orange-yellow crystals.

**Phosphomolybdic Acid Reagent;** Phosphomolybdic Reagent: Dissolve 2.5 g of *phosphomolybdic acid* in sufficient *glacial acetic acid* to produce 50 ml, add 2.5 ml of *sulphuric acid* and mix.

**Phosphomolybdic Acid Solution;** Phosphomolybdic Acid Spray Solution: A 5.0 per cent w/v solution of *phosphomolybdic acid* in *ethanol*.

**Phosphomolybdotungstic Reagent, Dilute:** To 1 volume of *phosphomolybdotungstic reagent* add 2 volumes of *water*.

**Phosphoric Acid:** Of the Indian Pharmacopoeia.

**Phosphoric Acid, x M:** Solutions of any molarity x M may be prepared by diluting 98x g of *phosphoric acid* to 1000 ml with *water*.

**Phosphoric Acid, Dilute:** Contains approximately 10 per cent w/v of  $\text{H}_3\text{PO}_4$ . Dilute 69 ml of *phosphoric acid* to 1000 ml with *water*.

**Phosphorus Pentoxide;** Diphosphorus Pentoxide:  $\text{P}_2\text{O}_5 = 141.95$

Grade specially supplied for use in desiccators.

White, amorphous, deliquescent powder; hydrated by *water* with evolution of heat.

**Phosphotungstic Acid:** Approximately  $24\text{WO}_3, \text{P}_2\text{O}_5, 51\text{H}_2\text{O} = 6625.08$

General laboratory reagent grade of commerce.

White or yellowish green crystals or crystalline powder.

**Phosphotungstic Acid Solution:** Dissolve 10 g of *sodium tungstate* in 75 ml of *water* and add 8 ml of *phosphoric acid*. Heat under a reflux condenser for 3 hours, allow to cool, filter and add sufficient *water* to produce 100 ml.

**Phthalaldehyde:**  $\text{C}_8\text{H}_6\text{O}_2 = 134.1$

General laboratory reagent grade of commerce.

Mp, about 55°.

**Phthalaldehyde Reagent:** Dissolve 2.47 g of *boric acid* in 75 ml of *water*, adjust the pH to 10.4 with a 45 per cent w/v solution of *potassium hydroxide* and add sufficient *water* to produce 100 ml. Dissolve 1.0 g of *phthalaldehyde* in 5 ml of *methanol*, add 95 ml of the *boric acid solution* and 2 ml of *thioglycollic acid* and adjust the pH to 10.4 with the potassium hydroxide solution.

Store protected from light and use within 3 days of preparation.

**Phthalazine;** 2,3-Benzodiazine; Benzo[d]pyridazine;  $\alpha$ -Phenodiazine:  $\text{C}_8\text{H}_6\text{N}_2 = 130.14$

General laboratory reagent grade of commerce.

Pale yellow needles from ether; mp, about 91°; bp, about 316°.

**Phthalylsulphathiazole:** Of the Indian Pharmacopoeia.

**Picric Acid:** 2,4,6-Trinitrophenol:  $\text{C}_6\text{H}_3\text{N}_3\text{O}_7 = 229.11$

Analytical reagent grade of commerce.

Bright yellow, crystalline powder or yellow prisms or plates moistened with an equal weight of *water* for safety; odourless; very bitter; explodes when heated rapidly or subjected to percussion; mp, about 122°.

*CAUTION* — When taking mp, the operator should be protected by a glass screen.

**Picric Acid Solution;** Trinitrophenol Solution: A 1.0 per cent w/v solution of *picric acid* in hot *water*.

**Picric Acid Solution, Alkaline;** Alkaline Trinitrophenol Solution; Sodium Picrate Solution, Alkaline: Mix 20 ml of *picric acid solution* with 10 ml of dilute *sodium hydroxide solution* and sufficient *water* to produce 100 ml.

The solution should be freshly prepared.

**Picrolonic Acid;** 3-Methyl-4-nitro-1-(4-nitrophenyl)-5-pyrazolone:  $\text{C}_{10}\text{H}_8\text{N}_4\text{O}_5 = 264.2$

General laboratory reagent grade of commerce.

Yellow or brownish yellow, crystalline powder; mp, about 116°.

Complies with the following additional test.

*SENSITIVITY* — Dissolve 25 mg in 10 ml of warm *water* containing 0.1 ml of *glacial acetic acid*. To 1 ml of this solution add 1 ml of a 0.05 per cent w/v solution of *calcium chloride* previously heated to 60°; a bulky precipitate is produced within 5 minutes.

**Piperazine Hydrate:** Of the Indian Pharmacopoeia.

**Plasma, Citrated Rabbit:** Collect blood by intracardiac puncture from a rabbit that has been fasted for 12 hours prior to the collection, using a plastic syringe with a No. 1 needle containing a suitable volume of a 3.8 per cent w/v solution of *sodium citrate* so that the final volume ratio of citrate solution to blood is 1: 9. Separate the plasma by centrifugation at 1500 to 1800 rpm at 15° to 20° for 30 minutes.

Store at 0° to 6° and use within 4 hours of collection.

**Plaster of Paris:** Of the Indian Pharmacopoeia.

**Polyethylene Glycol 300;** Macrogol 300

General laboratory reagent grade of commerce.

Clear, colourless or almost colourless, viscous liquid; wt. per ml, about 1.13 g; refractive index at 20°, about 1.465; viscosity, 71 centistokes at 25°.

**Polyethylene Glycol 400**; Macrogol 400: General laboratory reagent grade of commerce.

Clear, colourless or almost colourless, viscous liquid; wt. per ml, about 1.13 g; fp, about 6°; viscosity, about 7.1 centistokes at 100°.

**Polyethylene Glycol 600**; Macrogol 600: General laboratory reagent grade of commerce.

Clear, practically colourless, viscous liquid; odour, slightly characteristic; slightly hygroscopic; viscosity, between 9.9 and 11.1 centistokes at 100°.

**Polyethylene Glycol 1000**; Macrogol 1000: General laboratory reagent grade of commerce.

Colourless or white, solid mass with a waxy appearance; fp, about 35°; viscosity, about 17.3 centistokes at 100°.

**Polyethylene Glycol 20,000 2-Nitroterephthalate** General laboratory reagent grade of commerce.

White or almost white, hard, waxy solid.

**Polysorbate 20**: Of the Indian Pharmacopoeia.

**Polysorbate 80**: Of the Indian Pharmacopoeia.

**Potassium Acetate**:  $\text{CH}_3\text{COOK} = 98.14$

General laboratory reagent grade of commerce.

White powder, or granules or white crystals; odourless or having a faint acetous odour; taste, saline and slightly alkaline; very deliquescent.

**Potassium Antimonate**; Potassium Pyroantimonate:  $\text{KSbO}_3 \cdot 3\text{H}_2\text{O} = 262.90$

Analytical reagent grade of commerce.

White, crystalline powder.

**Potassium Antimonate Solution**: Boil 2 g of *potassium antimonate* with 95 ml of *water* until dissolved. Cool rapidly and add 50 ml of *potassium hydroxide solution* and 5 ml of *1 M sodium hydroxide*. Allow to stand for 24 hours, filter and add sufficient *water* to produce 150 ml.

Use freshly prepared solution.

**Potassium Bicarbonate**; Potassium hydrogen Carbonate:  $\text{KHCO}_3 = 100.12$

Analytical reagent grade of commerce.

Colourless, transparent, monoclinic prisms, or white, granular powder.

**Potassium Bicarbonate Solution, Saturated Methanolic**: Dissolve 0.1 g of *potassium bicarbonate* in 0.4 ml of *water* by

heating on a water-bath. Add 25 ml of *methanol* and swirl, keeping the solution on the water-bath until dissolution is complete.

Prepare immediately before use.

**Potassium Bisulphate**: Potassium Hydrogen Sulphate;  $\text{KHSO}_4 = 136.16$

Analytical reagent grade of commerce.

Fused, white lumps, or colourless, transparent, hygroscopic crystals.

**Potassium Bromate**:  $\text{KBrO}_3 = 167.00$

Analytical reagent grade of commerce.

White, granular powder or crystals.

**Potassium Bromate, 0.0167 M**: Dissolve 2.783 g of *potassium bromate* in sufficient *water* to produce 1000 ml.

**Potassium Bromate, 0.0333 M**: Dissolve 5.566 g of *potassium bromate* in sufficient *water* to produce 1000 ml.

**Potassium Bromide**:  $\text{KBr} = 119.00$

Analytical reagent grade of commerce.

Colourless crystals or white, crystalline powder; odourless.

**Potassium Bromide, 0.001 M**: Dissolve 0.1190 g of *potassium bromide* in sufficient *water* to produce 1000 ml.

**Potassium Bromide IR**: Spectroscopic reagent grade complying with the following test.

The infra-red absorption spectrum (2.4.6) of a disc 2 mm thick prepared from the material, previously dried at 250° for 1 hour, has a substantially flat baseline over the range 4000 to 625  $\text{cm}^{-1}$ , it exhibits no maxima with an absorbance greater than 0.02 above the base line with the exception of maxima due to *water* at 3440 and 1630  $\text{cm}^{-1}$ .

**Potassium Carbonate**: Anhydrous Potassium carbonate:  $\text{K}_2\text{CO}_3 = 138.21$

Analytical reagent grade of commerce.

White, granular powder; hygroscopic.

**Potassium Carbonate, 2 M**: Dissolve 276.42 g of *potassium carbonate* in sufficient *water* to produce 1000 ml.

**Potassium Carbonate Sesquihydrate**:  $\text{K}_2\text{CO}_3 \cdot 1\frac{1}{2}\text{H}_2\text{O} = 165.23$

General laboratory reagent grade of commerce.

**Potassium Chlorate**:  $\text{KClO}_3 = 122.55$

Analytical reagent grade of commerce.

White powder, granules or colourless crystals.

**CAUTION** — *In admixture with organic or readily oxidisable substances, it is liable to explode if heated or subjected to percussion trituration.*

**Potassium Chloride:** Of the Indian Pharmacopoeia.

**Potassium Chloride IR:** Spectroscopic reagent grade complying with the requirement stated under Potassium Bromide IR.

**Potassium Chromate:**  $K_2CrO_4 = 194.19$

Analytical reagent grade of commerce.

Yellow Crystals.

**Potassium Chromate Solution:** A 5.0 per cent w/v solution of *potassium chromate*.

**Potassium Cupri-Tartrate Solution;** Alkaline Cupric-Tartrate Solution; Fehling's Solution.

**SOLUTION I (COPPER SOLUTION)** — Dissolve 34.66 g of carefully selected small crystals of *cupric sulphate*, showing no trace of efflorescence or of adhering moisture, in sufficient *water* to produce 500 ml. Store this solution in small, well stoppered bottles.

**SOLUTION II (ALKALINE TARTRATE SOLUTION)** — Dissolve 176 g of *sodium potassium tartrate* and 77 g of *sodium hydroxide* in sufficient *water* to produce 500 ml.

Mix equal volumes of the solutions (I) and (II) immediately before use.

**Potassium Cyanide:**  $KCN = 65.12$

Analytical reagent grade of commerce.

White, crystalline powder or white mass or crystals, gradually decomposing on exposure to air.

**Potassium Cyanide Solution:** A 10.0 per cent w/v solution of *potassium cyanide*.

**Potassium Cyanide Solution Sp.:** Dissolve 50 g of *potassium cyanide* in sufficient *water* to produce 100 ml. Remove the lead from this solution by extraction with successive quantities, each of 20 ml, of *dithizone extraction solution* until the *dithizone solution* retains its orange green colour. Extract any *dithizone* remaining in the cyanide solution by shaking with *chloroform*. Dilute this cyanide solution with sufficient *water* to produce a solution containing 10 g of potassium cyanide in each 100 ml.

**Potassium Dichromate:**  $K_2Cr_2O_7 = 294.18$

Analytical reagent grade of commerce.

Orange-red crystals or crystalline powder.

Potassium dichromate used for the calibration of spectrophotometers contains not less than 99.9 per cent of  $K_2Cr_2O_7$ , calculated with reference to the substance dried at  $130^\circ$ .

**ASSAY** — Dissolve 1 g in sufficient *water* to produce 250 ml. Add 50 ml of this solution in a freshly prepared solution of 4 g

of *potassium iodide*, 2 g *sodium bicarbonate* and 6 ml of *hydrochloric acid* in 100 ml of *water* in a 500 ml flask. Stopper the flask and allow to stand protected from light for 5 minutes. Titrate with 0.1 M *sodium thiosulphate* using 1 ml of *iodide-free starch solution*, added towards the end of the titration, as indicator. 1 ml of 0.1 M *sodium thiosulphate* is equivalent to 0.004903 g of  $K_2Cr_2O_7$ .

**Potassium Dichromate Solution:** A 10.6 per cent w/v solution of *potassium dichromate*.

**Potassium Dichromate Solution, Dilute:** A 7.0 per cent w/v solution of *potassium dichromate*.

**Potassium Dichromate Solution UV:** Dry a quantity of *potassium dichromate* by heating to constant weight at  $130^\circ$ . Weigh accurately a quantity not less than 57.0 mg and not more than 63.0 mg and dissolve in sufficient 0.005 M *sulphuric acid* to produce 1000 ml.

**Potassium Dihydrogen Citrate;** Monobasic Potassium Citrate:  $KH_2C_6H_5O_7 = 230.21$

General laboratory reagent grade of commerce.

White, Crystalline powder.

**Potassium Dihydrogen Phosphate;** Potassium Dihydrogen Orthophosphate:  $KH_2PO_4 = 136.09$

Analytical reagent grade of commerce.

Colourless or white, crystalline powder.

**Potassium Dihydrogen Phosphate, x M:** Solutions of any molarity xM may be prepared by dissolving 136.09x g of *potassium dihydrogen phosphate* in sufficient *water* to produce 1000 ml.

**Potassium Ferricyanide;** Potassium Hexacyanoferrate(III):  $K_3Fe(CN)_6 = 329.25$

Analytical reagent grade of commerce.

Ruby-red crystals.

**Potassium Ferricyanide Solution:** Wash about 5 g of *potassium ferricyanide* crystals with a little *water* and dissolve the washed crystals in 100 ml of *water*.

Prepare immediately before use.

**Potassium Ferricyanide Solution, Dilute:** Wash about 1 g of *potassium ferricyanide* crystals with a little *water* and dissolve the washed crystals in 100 ml of *water*.

Produces a blue colour with solutions of iron salts.

Prepare immediately before use.

**Potassium Ferrocyanide;** Potassium Hexacyanoferrate(II):  $K_4Fe(CN)_6 \cdot 3H_2O = 422.39$

Analytical reagent grade of commerce.

Transparent, yellow crystalline powder.



**Potassium Ferrocyanide Solution:** A 5.0 per cent w/v solution of *potassium ferrocyanide*.

**Potassium Ferrocyanide Solution, Dilute:** A 1.0 per cent w/v solution of *potassium ferrocyanide*.

Prepare immediately before use.

**Potassium Hydrogen Phthalate:**  $\text{COOH}\cdot\text{C}_6\text{H}_4\text{COOK} = 204.22$ .

Analytical reagent grade of commerce.

White, crystalline powder.

**Potassium Hydrogen Phthalate, x M:** Dissolve  $204.22x$  g of *potassium hydrogen phthalate* in about 800 ml of *anhydrous glacial acetic acid*, heat on a *water bath* until completely dissolved, protected from humidity, cool to  $20^\circ$  and add sufficient *anhydrous glacial acetic acid* to produce 1000 ml.

**Potassium Hydrogen (+)-Tartrate:**  $\text{C}_4\text{H}_5\text{KO}_6 = 188.2$

Analytical reagent grade of commerce.

White, crystalline powder or colourless, slightly opaque crystals.

**Potassium Hydroxide;** Caustic Potash:  $\text{KOH} = 56.11$

Analytical reagent grade of commerce.

Contains not less than 85.0 per cent of total alkali calculated as  $\text{KOH}$  and not more than 2.0 per cent of  $\text{K}_2\text{CO}_3$ .

Dry, white sticks or slabs, pellets or fused mass; hard, brittle and showing a crystalline fracture; very deliquescent; strongly alkaline and corrosive.

Store protected from light and moisture.

**Potassium Hydroxide, x M:** Solutions of any molarity  $xM$  may be prepared by dissolving  $56.11x$  g of *potassium hydroxide* in sufficient *water* to produce 1000 ml.

**Potassium Hydroxide Solution, Ethanolic:** A 10 per cent w/v solution of *potassium hydroxide* in *ethanol*.

Prepare immediately before use.

**Potassium Hydroxide Solution, Dilute Ethanolic:** Dissolve 3 g of *potassium hydroxide* in 5 ml of *water* and dilute to 100 ml with *aldehyde-free ethanol* (95 per cent), allow to stand for 1 hour and decant the clear solution.

Prepare immediately before use.

**Potassium Hydroxide, x M Ethanolic:** Solutions of any molarity  $x M$  may be prepared by dissolving  $56.11x$  g of *potassium hydroxide* in sufficient *ethanol* (95 per cent) to produce 1000 ml.

**Potassium Hydroxide Solution:** A 5 per cent w/v solution of *potassium hydroxide*.

**Potassium Iodate:**  $\text{KIO}_3 = 214.00$

Analytical reagent grade of commerce.

White, crystalline powder.

**Potassium Iodate, x M:** Solutions of any molarity  $x M$  may be prepared by dissolving  $214.00x$  g of *potassium iodate* in sufficient *water* to produce 1000 ml.

**Potassium Iodate Solution:** A 1.0 per cent w/v solution of *potassium iodate*.

**Potassium Iodide:** Of the Indian Pharmacopoeia.

**Potassium Iodide, 1 M:** Dissolve 166.00 g of *potassium iodide* in sufficient *water* to produce 1000 ml.

**Potassium Iodide and Starch Solution:** Dissolve 10 g of *potassium iodide* in sufficient *water* to produce 95 ml and add 5 ml of *starch solution*.

Complies with the following test.

**SENSITIVITY TO IODINE** — To 15 ml of the solution add 0.05 ml of *glacial acetic acid* and 0.3 ml of  $0.0005 M$  *iodine*; a blue colour is produced.

Prepare immediately before use.

**Potassium Iodide Solution:** A 16.6 per cent w/v solution of *potassium iodide*.

**Potassium Iodide Solution, Dilute:** A 10 per cent w/v solution of *potassium iodide*.

**Potassium Iodide Solution, Iodinated:** Dissolve 2 g of *iodine* and 4 g of *potassium iodide* in 10 ml of *water*. When solution is complete, add sufficient *water* to produce 100 ml.

**Potassium Iodobismuthate Solution:** Dissolve 100 g of *tartaric acid* in 400 ml of *water* and add 8.5 g of *bismuth subnitrate*. Shake during 1 hour, add 200 ml of a 40 per cent w/v solution of *potassium iodide* and shake well. Allow to stand for 24 hours and filter.

Store protected from light.

**Potassium Iodobismuthate Solution, Acetic;** Potassium Iodobismuthate solution, Acid: Dissolve 8 g of *potassium iodide* in sufficient *water* to produce 20 ml and add the solution to a mixture of 0.85 g of *bismuth subnitrate*, 40 ml of *water* and 10 ml of *glacial acetic acid*.

**Potassium Iodobismuthate Solution, Dilute:** Dissolve 100 g of *tartaric acid* in 500 ml of *water* and add 50 ml of *potassium iodobismuthate solution*.

**Potassium Iodobismuthate Solution, Modified:** Suspend 1.7 g of *bismuth subnitrate* and 20 g of *tartaric acid* in 40 ml of *water*. To the suspension add 40 ml of a 40 per cent w/v solution of *potassium iodide*, stir for 1 hour and filter. This stock solution may be kept for several days in light-resistant containers.

Mix 5 ml of the stock solution with 15 ml of *water* immediately before use.

**Potassium Iodoplatinate solution:** Add 50 ml of a 5 per cent w/v solution of chloroplatinic acid to 45 ml of *potassium iodide solution* and dilute to 100 ml with *water*.

Store in amber-coloured, glass containers.

**Potassium Mercuri-Iodide Solution;** Mayer's reagent: Add 1.36 g of *mercuric chloride* dissolved in 60 ml of *water* to a solution of 5 g of *potassium iodide* in 20 ml of *water*, mix and add sufficient *water* to produce 100 ml.

**Potassium Mercuri-Iodide Solution, Alkaline;** Nessler's Reagent: To 3.5 g of *potassium iodide* add 1.25 g of *mercuric chloride* dissolved in 80 ml of *water*, add a cold, saturated solution of *mercuric chloride* in *water*, with constant stirring until a slight red precipitate remains. Dissolve 12 g of *sodium hydroxide* in the solution, add a little more of the cold saturated solution of *mercuric chloride* and sufficient *water* to produce 100 ml. Allow to stand and decant the clear, supernatant liquid.

**Potassium monoethyl sulphate:**  $KC_2H_5SO_4 = 164.19$

Laboratory reagent grade of commerce.

**Potassium Nitrate:**  $KNO_3 = 101.10$

Analytical reagent grade of commerce.

Colourless crystals or white, crystalline powder; odourless; taste, cool and saline.

**Potassium Permanganate:** Of the Indian Pharmacopoeia.

**Potassium Permanganate, x M:** Solutions of any molarity x M may be prepared by dissolving 158x g of *potassium permanganate* in 900 ml of *water*, heating on a *water*-bath for 1 hour, cooling, filtering through a sintered-glass filter and adding sufficient *water* to produce 1000 ml.

Store protected from moisture.

**Potassium Permanganate-Phosphoric Acid Solution;** Potassium Permanganate and Phosphoric Acid Solution; Potassium Permanganate-Orthophosphoric acid Reagent: Dissolve 3 g of *potassium permanganate* in a mixture of 16 ml of *phosphoric acid* and 70 ml of *water* and add sufficient *water* to produce 100 ml.

**Potassium Permanganate Solution;** Potassium Permanganate Solution, Strong: A 3.0 per cent w/v solution of *potassium permanganate*.

**Potassium Permanganate Solution, Dilute:** A 1.0 per cent w/v solution of *potassium permanganate*.

**Potassium Sulphate;** Dipotassium Sulphate:  $K_2SO_4 = 174.25$ .

Analytical reagent grade of commerce.

White or colourless crystals.

**Potassium Tellurite:**  $K_2TeO_3$  (approx)

General laboratory reagent grade of commerce.

White granular powder.

**Potassium Tetraoxalate;** Potassium Trihydrogen Dioxalate:  $KH_3(C_2H_4)_2, 2H_2O = 254.19$

Analytical reagent grade of commerce.

White, crystalline powder.

**Potassium thiocyanate:**  $KCNS = 97.18$

Analytical reagent grade of commerce.

Colourless crystals; deliquescent.

**Potassium Thiocyanate Solution:** A 9.7 per cent w/v solution of *potassium thiocyanate*.

**1-Propanol;** Propan-1-ol; *n*-Propyl Alcohol:  $CH_3CH_2CH_2OH = 60.10$

Analytical reagent grade of commerce.

Colourless liquid; bp, about 97°; wt. per ml, about 0.804 g

**2-Propanol; Isopropyl Alcohol:** Of the Indian Pharmacopoeia.

*2-propanol intended for use in spectrophotometry complies with the following test.*

**ABSORBANCE (2.4.1)** — Absorbance in the range 320 to 350 nm, measured against *water* as the blank, not more than 0.01 and at about 300 nm, not more than 0.05.

**2-Propanol, Anhydrous;** Propan-2-ol, Anhydrous: Boil 500 ml of *2-propanol* under a reflux condenser with 5 g of *stannous chloride* for 30 minutes. Test for the absence of peroxides by adding 0.5 ml of the cooled solution to 1 ml of *dilute potassium iodide solution* acidified with 0.5 ml of *2 M hydrochloric acid* and adding 0.1 ml of *starch solution*. The absence of a blue colour after standing for 1 minute indicates the absence of peroxides.

If peroxides are still present, add 2.5 g of *stannous chloride* and boil under a reflux condenser for another 30 minutes. Repeat the procedure until the test shows the absence of peroxides. Add 100 g of *calcium oxide*, boil under a reflux condenser for 4 hours and distil, discarding the first 100 ml and taking adequate precautions to exclude moisture.

**Propionaldehyde;** Propanal:  $C_3H_6O = 58.08$

General laboratory reagent grade of commerce.

Liquid; odour, suffocating; bp, about 49°; refractive index at 20°, about 1.365; wt. per ml, about 0.81 g.

**Propylene Glycol:** Of the Indian Pharmacopoeia.

**Propyl Gallate:** Of the Indian Pharmacopoeia.

**Pumice Powder:** The particles of pumice of commerce, powdered and sifted, which passes through a *No. 22 sieve*, but are retained by a *No. 60 sieve*.

**Pumice Stone:** A substance of volcanic origin consisting chiefly of complex silicates of aluminium and alkali metals. Very light, hard, rough, porous, greyish masses; odourless; stable in air.

**Purine:**  $C_5H_4N_4 = 120.11$

White to off-white powder.

**MELTING RANGE** — Between  $214^\circ$  and  $217^\circ$ .

**Pyridine:**  $C_5H_5N = 79.10$

Analytical reagent grade of commerce.

Clear, colourless liquid; odour, characteristic and unpleasant; hygroscopic; bp, about  $115^\circ$ ; refractive index at  $20^\circ$ , about 1.510; wt. per ml, about 0.98 g.

**Pyridine, Anhydrous;** Pyridine, Dehydrated: Dry *pyridine* over *anhydrous sodium carbonate*, filter and distil.

Complies with the following additional test.

**WATER** (2.3.43) — Not more than 0.01 per cent w/w.

**Pyridine Bromide Solution:** Dissolve 8 g of *pyridine* and 5.4 ml of *sulphuric acid* in 20 ml of *glacial acetic acid*, keeping the mixture cool. Add 2.5 ml of *bromine* dissolved in 20 ml of *glacial acetic acid* and dilute with *glacial acetic acid* to 1000 ml.

Prepare immediately before use.

**Pyridine-Acetic Anhydride Reagent:** Just before use, add cautiously with cooling 25 ml of freshly distilled *acetic anhydride* to 50 ml of freshly distilled *anhydrous pyridine*, cool and dilute with freshly distilled *anhydrous pyridine* to 100 ml.

**Pyrimethamine:** Of the Indian Pharmacopoeia.

**Pyrogallol;** 1,2,3-Trihydroxybenzene:  $C_6H_3(OH)_3 = 126.11$

General laboratory reagent grade of commerce.

White or slightly discoloured, light or heavy crystals; mp, about  $133^\circ$ .

Store protected from light.

**Pyrogallol Solution, Alkalinic:** Dissolve 0.5 g of *pyrogallol* in 2 ml of *water*; dissolve 12 g *potassium hydroxide* in 8 ml of *water*. Mix the two solutions immediately before use.

**Quinhydrone;** Cyclohexa-2,5-diene-1,4-dione compound with Benzene-1,4-diol:  $C_{12}H_{10}O_4 = 218.21$

Analytical reagent grade of commerce.

Dark green, lustrous crystals or crystalline powder; mp, about  $171^\circ$ .

**Quinidine Sulphate:** Of the Indian Pharmacopoeia.

**Quinine:**  $C_{20}H_{24}N_2O_2 \cdot 3H_2O = 378.46$

General laboratory reagent grade of commerce.

Microcrystalline powder; efflorescent; mp, about  $57^\circ$ , with decomposition;  $[\alpha]_D^{20}$ , about  $-167^\circ$  (1 per cent in *ethanol*).

Store protected from light.

**Quinine Sulphate:** Of the Indian Pharmacopoeia.

**Quinoline:**  $C_9H_7N = 129.15$

General laboratory reagent grade of commerce, suitable for phosphate assay.

Clear, pale yellow liquid; odour, characteristic and unpleasant; hygroscopic; bp, about  $237^\circ$ ; refractive index at  $20^\circ$ , about 1.626; wt. per ml, about 1.095 g.

Complies the following test.

**TARRY IMPURITIES** — Dissolve 1.0 g in a mixture of 2.5 ml of *water* and 2.5 ml of *hydrochloric acid*. Add 3 ml of *water* and 1 ml of *potassium chromate solution* and heat to boiling; the solution shows no darkening and no black deposit.

Store protected from light.

**Quinoline Solution:** Dissolve 50 ml of *quinoline* in a mixture of 60 ml of *hydrochloric acid* and 300 ml of *water*, previously heated to  $70^\circ$ , cool and filter.

**Rabbit Erythrocyte Suspension:** Prepare a 1.6 per cent w/v suspension of rabbit erythrocytes in the following manner. Defibrinate 15 ml of freshly drawn rabbit blood by shaking with glass beads, centrifuge at 2000 rpm for 10 minutes and wash the erythrocytes with three quantities, each of 30 ml of *saline solution*. Dilute 1.6 ml of the suspension of erythrocytes to 100 ml with a mixture of 1 volume of *phosphate buffer pH 7.2* and 9 volumes of *saline solution*.

**Resorcinol;** Resorcin; Benzene-1,3-diol; 1,3-dihydroxybenzene:  $C_6H_4(OH)_2 = 110.11$

Analytical reagent grade of commerce.

Colourless or nearly colourless needle-shaped crystals or powder; odour, slight but characteristic; mp, about  $111^\circ$ .

**Resorcinol Solution:** Shake 0.2 g of *resorcinol* with 100 ml of *toluene* until saturated and decant.

Prepare immediately before use.

**Rhodamine B;** CI 45170; Basic Violet 10; D & C Red No. 19; Tetraethylrhodamine; *N*-[9-(2-Carboxyphenyl)-6-(diethylamino)-3H-xanthen-3-ylidene]-*N*-ethylethanaminium Chloride:  $C_{28}H_{31}ClN_2O_3 = 479.02$

General laboratory reagent grade of commerce.

Green crystals or reddish violet powder.

**Salicylaldehyde;** 2-Hydroxybenzaldehyde:  $C_7H_6O_2 = 122.12$

General laboratory reagent grade of commerce

Clear, colourless, oily liquid; odour, characteristic; bp, about  $196^\circ$ ; refractive index at  $20^\circ$ , about 1.574; wt. per ml, about 1.167 g.

**Salicylic Acid:** Of the Indian Pharmacopoeia.

**Saline Solution:** A 0.9 per cent w/v solution of *sodium chloride* in freshly distilled *water*, sterilised by heating in an autoclave (2.2.11).

**Saline Solution, Pyrogen-free:** *Saline solution* complying with the pyrogens (2.2.8).

**Saline Solution, Sterile:** Of the Indian Pharmacopoeia.

**Semicarbazide Acetate Solution:** Triturate 2.5 g of *semicarbazide hydrochloride* with 3.3 g of *sodium acetate*, add 10 ml of *methanol*, mix, transfer to a flask with the aid of 20 ml of *methanol*, allow to stand at a temperature of about 4° for 30 minutes, filter and add sufficient *methanol* to produce 100 ml.

**Semicarbazide Hydrochloride:**  $\text{NH}_2\text{CONHNH}_2\cdot\text{HCl} = 111.53$ .

Analytical reagent grade of commerce.

White to yellowish white crystals or crystalline powder; mp, about 176°, with decomposition.

**Selenium Dioxide:**  $\text{SeO}_2 = 110.96$

General reagent grade of commerce.

**Serum Solution:** Dilute 1 volume of *serum stock solution* with 3 volumes of *acetate buffer solution* and adjust to room temperature.

Use on the day of preparation.

**Serum Stock Solution:** Dilute 1 volume of cattle or horse serum (native or reconstituted with *water* to its original volume) with 9 volumes of *acetate buffer solution*. Adjust the pH to 3.1 with 4 M *hydrochloric acid* and allow to stand for 18 to 24 hours.

Store at 0° to 4° and use within 30 days.

**Sesame Oil:** Refined fixed oil obtained from the seeds of one or more cultivated varieties of *Sesamum indicum*.

Pale yellow oil; almost odourless; wt. per ml, about 0.92 g.

**Silica Gel;** Silica Gel for Chromatography: A grade of commerce suitable for column chromatography.

Precipitated silicic acid in form of lustrous granules.

**Silica Gel, Anhydrous;** Silica Gel, self-indicating: A grade of commerce consisting of partially dehydrated, polymerised, colloidal silicic acid containing cobalt chloride as an indicator.

Blue granules, becoming pink when the moisture adsorption capacity is exhausted. Anhydrous silica gel absorbs about 30 per cent of its weight of water at 20°. Its adsorptive capacity may be regenerated by heating at 150° for 2 hours.

**Silica Gel, Butylsilyl;** Butylsilyl Silica Gel for Chromatography: A grade of commerce suitable for column chromatography. A very finely divided Silica Gel (3 to 10 mm) chemically modified at the surface by the introduction of butylsilyl groups. The

particle size is indicated after its name in tests where it is specified for use.

**Silica Gel F254;** Fine, white, homogeneous powder of an average particle size of less than 30 mm containing a fluorescent indicator having a maximum intensity at about 254 nm used for thin-layer chromatography. (Merck silica gel 60 F254 precoated plates are generally satisfactory).

**Silica Gel G:** Fine, white, homogeneous powder of an average particle size between 10 and 20 mm containing about 13 per cent w/w of calcium sulphate hemihydrate ( $\text{CaSO}_4\cdot\frac{1}{2}\text{H}_2\text{O}$ ).

Complies with the following tests.

**CALCIUM SULPHATE CONTENT** — Carry out the test described under Aluminium Oxide G.

**pH (2.4.24)** — About 7, determined in a suspension prepared by shaking 1 g with 10 ml of *carbon dioxide-free water* for 5 minutes.

**SEPARATING POWER** — Determine by thin-layer chromatography (2.4.17), coating the plate with *silica gel G*.

*Mobile phase. Toluene.*

*Test solution.* A solution in dichloromethane containing 0.01 per cent w/v of each of dimethyl yellow, indophenol blue and sudan red G in *toluene*.

Apply to the plate 10  $\mu\text{l}$  of the solution. Allow the mobile phase to rise 10 cm. The chromatogram shows three clearly separated spots, the spot due to indophenol blue near the starting point, that due to dimethyl yellow in the middle of the chromatogram and that due to sudan red G between the two.

**Silica Gel GF254;** Silica Gel G/UV254: Fine, white, homogeneous powder of an average particle size between 10 and 20 mm containing about 13 per cent w/w of calcium sulphate hemihydrate ( $\text{CaSO}_4\cdot\frac{1}{2}\text{H}_2\text{O}$ ) and about 1.5 per cent w/w of a fluorescent indicator having a maximum intensity at about 254 nm.

Complies with the test for **CALCIUM SULPHATE CONTENT** described under Aluminium Oxide G, with the tests for pH and **SEPARATING POWER** described under Silica Gel G and with the following test.

**FLUORESCENCE** — Determine by thin-layer chromatography (2.4.17), coating the plate with *silica gel G*.

*Mobile phase.* A mixture of 90 volumes of 2-propanol and 10 volumes of *anhydrous formic acid*.

*Test solution.* A 0.1 per cent w/v solution of *benzoic acid* in the same solvent mixture

Apply separately to the plate increasing quantities from 1 to 10 ml of. After development, dry the plate in a current of warm air and examine under ultra-violet light at 254 nm. The benzoic acid appears as dark spots on a fluorescent background in the



upper third of the chromatogram at levels of 2 mg and greater.

**Silica Gel H:** Fine, white, homogeneous powder of an average particle size between 10 mm and 20 mm.

Complies with the tests for pH and SEPARATING POWER described under Silica Gel G.

**Silica Gel H, Silanised:** Fine, white, homogeneous powder which, after shaking with *water*, floats on the surface because of its *water*-repellent properties. It complies with the test for pH described under Silica Gel G and with the following test.

**SEPARATING POWER** — Determine by thin-layer chromatography (2.4.17), prepared in the following manner. Vigorously shake 30 g of the silica gel for 2 minutes with 60 ml of a mixture of 2 volumes of *water* and 1 volume of *methanol* and, using a spreading device designed for the purpose, spread a uniform layer of the suspension about 0.25 mm thick on a series of carefully cleaned glass plates measuring 20 cm × 5 cm. Allow the coated plates to dry in air and heat in an oven at 105° to 110° for 30 minutes.

*Mobile phase.* A mixture of 65 volumes of *dioxan*, 25 volumes of *water* and 10 volumes of *glacial acetic acid*.

*Test solution.* A mixture of 0.1 g of each of methyl laurate, methyl myristate, methyl palmitate and methyl stearate add 40 ml of a decanted 3 per cent w/v solution of potassium hydroxide in *ethanol (90 per cent)* and heat under a reflux condenser on a *water*-bath for 1 hour. Cool, add 100 ml of *water*, acidify the mixture with 2 M *hydrochloric acid* and extract with three quantities, each of 10 ml, of *chloroform*. Dry the combined chloroform extracts over *anhydrous sodium sulphate*, filter, evaporate the filtrate to dryness and dissolve the residue in 50 ml of *chloroform*.

Apply separately to the plate three quantities, each of 10 ml. After development, dry the plate by heating in an oven at 120° for 30 minutes. Allow to cool and spray with a 3.5 per cent w/v solution of phosphomolybdic acid in 2-propanol at 150° until the spots become visible. Expose the plate to ammonia vapour until the background turns white; each chromatogram shows 4 clearly separated spots.

**Silica Gel HF254;** Silica Gel H/UV 254: Fine, white, homogeneous powder of an average particle size between 10 and 20 mm containing about 1.5 per cent w/w of a fluorescent indicator having a maximum intensity at about 254 nm.

Complies with the tests for pH and SEPARATING POWER described under Silica Gel G and with the test for FLUORESCENCE described under Silica Gel GF254.

**Silica Gel HF254, Silanised:** Fine, white, homogeneous powder which after shaking with *water*, floats on the surface because of the *water*-repellent properties.

Complies with the test for SEPARATING POWER described under Silanised Silica Gel H.

**Silica Gel, Strong Anion-exchange:** A strong anion exchange packing for high performance liquid chromatography made by chemically bonding a quaternary amine to a silica spherical core, 10 mm to 50 mm in diameter, the particle size being generally indicated by the number after the name of the reagent, e.g. Partisil 10 SAX.

**Siliceous Earth, Chromatographic:** For gas chromatography, use a specially prepared grade meeting the following general description.

Purified siliceous earth of suitable mesh size that has been acid-and/or base-washed. It may or may not be silanised.

For column partition chromatography, it is essential that the material be free from interfering substances. If such interferences are known or thought to be present, purify the material as follows. Place a pledget of glass wool in the base of a chromatographic column having a diameter of 100 mm or larger and add *purified siliceous earth* to a height equal to 5 times the diameter of the column. Add a volume of *hydrochloric acid* equivalent to one-third the volume of the siliceous earth and allow the acid to percolate into the column. Wash the column with *methanol*, using small volumes at first to rinse the walls of the column, and continue washing with *methanol* until the last washing is neutral to moistened *litmus paper*. Extrude the washed column into shallow dishes, heat on a steam-bath to remove the excess *methanol* and dry at 105° until the material is powdery and free from traces of methanol. Store the dried material in well-closed containers.

**Siliceous Earth, Purified:** Purified siliceous earth is a form of silica (SiO<sub>2</sub>) consisting of the frustules and fragments of diatoms purified by calcining.

Store protected from moisture.

**Silicon Dioxide:** SiO<sub>2</sub>·xH<sub>2</sub>O

General laboratory reagent grade of commerce.

Fine, white, hygroscopic, odourless, amorphous powder; diameter of the average particles, between 2 mm and 10 mm.

**Silicon Dioxide, Anhydrous:** SiO<sub>2</sub> = 60.08

Analytical reagent grade of commerce.

Transparent crystals.

**Silicone Oil:** Use Dimethicone or any other silicone oil.

**Silver Nitrate:** Of the Indian Pharmacopoeia.

**Silver Nitrate, x M:** Solutions of any molarity xM may be prepared by dissolving 170x g of *silver nitrate* insufficient *water* to produce 1000 ml.

Store protected from light.

**Silver Nitrate Solution:** A 5.0 per cent w/v solution of *silver nitrate*.

Store protected from light.

**Silver Nitrate Solution, Ammonical;** Silver Ammonio-nitrate Solution: Dissolve 2.5 g of *silver nitrate* in 80 ml of *water* and cautiously add *dilute ammonia solution* until the precipitate first formed is nearly dissolved; set aside, decant and add sufficient *water* to produce 100 ml.

Prepare immediately before use.

*CAUTION* — Dry ammonical silver nitrate is very explosive.

**Silver Nitrate Solution, Dilute:** A 1.7 per cent w/v solution of *silver nitrate*.

Store protected from light.

**Silver Nitrate Solution, Methanolic:** Boil, until dissolved, 5 g of *silver nitrate* with 60 ml of *methanol* under reflux on a water-bath. Use the solution while still hot.

**Silver Nitrate-Pyridine Reagent;** Silver Nitrate Solution in Pyridine: A 5.0 per cent w/v solution of *silver nitrate* in *pyridine*.

**Silver Oxide:**  $\text{Ag}_2\text{O} = 231.74$ .

General laboratory reagent grade of commerce.

Brownish black powder.

Store protected from light and moisture. Do not expose to ammonia fumes or easily oxidisable substances.

**Soda Lime:** General purpose grade of commerce. White granules, about 4 to 10 mesh (1.7 to 4.0 mm).

**Sodium:**  $\text{Na} = 22.99$

General laboratory reagent grade of commerce.

Soft silvery grey metal.

Store under light petroleum or liquid paraffin.

**Sodium Acetate:** Of the Indian Pharmacopoeia.

**Sodium Acetate, Anhydrous:**  $\text{CH}_3\text{COONa} = 82.03$

Analytical reagent grade of commerce.

White, pale-grey or very pale brown, crystalline masses; hygroscopic.

Complies with the following test.

**LOSS ON DRYING** — Not more than 2 per cent when dried at  $105^\circ$ .

**Sodium Acetate Solution, 0.1 M:** Dissolve 13.61 g of *sodium acetate* in sufficient *water* to produce 1000 ml.

**Sodium Acid Citrate;** Disodium Hydrogen Citrate:  $\text{C}_6\text{H}_6\text{Na}_2\text{O}_7, 1\frac{1}{2}\text{H}_2\text{O} = 263.11$

General laboratory reagent grade of commerce.

White powder; odourless or almost odourless.

**Sodium Arsenite;** Sodium Metaarsenite:  $\text{NaAsO}_2 = 129.91$

General laboratory reagent grade of commerce.

White or greyish white powder; somewhat hygroscopic.

**Sodium Arsenite, 0.1 M:** Dissolve 9.892 g of *arsenic trioxide* in 80 ml of *1 M sodium hydroxide*, dilute to 800 ml with *water* and add *2 M hydrochloric acid* until the solution is neutral to *litmus paper*. Add 2 g of *sodium bicarbonate*, dissolve by stirring and dilute with *water* to produce 1000 ml.

**Sodium Arsenite Solution:** Dissolve 0.50 g of *arsenic trioxide* in 5 ml of *2 M sodium hydroxide* and add 2.0 g of *sodium bicarbonate* and sufficient *water* to produce 100 ml.

**Sodium Bicarbonate:** Of the Indian Pharmacopoeia.

**Sodium Bicarbonate, x M:** Solutions of any molarity xM may be prepared by dissolving  $84.01x$  g of *sodium bicarbonate* in sufficient *water* to produce 1000 ml.

**Sodium Bicarbonate Solution:** A 5 per cent w/v solution of *sodium bicarbonate*.

**Sodium Bismuthate:**  $\text{NaBiO}_3 = 280.00$

Analytical reagent grade of commerce containing not less than 85.0 per cent of  $\text{NaBiO}_3$ .

Yellow to yellowish brown powder, slowly decomposing when moist or at a high temperature.

**ASSAY** — Suspend 0.2 g in 10 ml of a 20 per cent w/v solution of *potassium iodide* and add 20 ml of *1 M sulphuric acid*. Titrate with *0.1 M sodium thiosulphate* using 1 ml of *starch solution*, added towards the end of the titration, as indicator until an orange solution is produced. 1 ml of *0.1 M sodium thiosulphate* is equivalent to 0.01400 g of  $\text{NaBiO}_3$ .

**Sodium Bisulphite;** Sodium Acid Sulphite:  $\text{NaHSO}_3 = 104.07$

White or yellowish white crystals or granular powder, odour, of sulphur dioxide; unstable in air.

Consists of sodium bisulphite,  $\text{NaHSO}_3$ , and sodium metabisulphite,  $\text{Na}_2\text{S}_2\text{O}_5$ , in varying proportions and yielding not less than 58.5 per cent w/w and not more than 67.4 per cent w/w of  $\text{SO}_2$ , determined by the following method.

**ASSAY** — Weigh accurately about 0.2 g, transfer to a glass-stoppered flask, add 50 ml of *0.1 M iodine* and insert the stopper. Allow to stand for 5 minutes, add 1 ml of *hydrochloric acid* and titrate the excess of iodine with *0.1 M sodium thiosulphate* using *starch solution*, added towards the end of the titration, as indicator. 1 ml of *0.1 M iodine* is equivalent to 0.003203 g of  $\text{SO}_2$ .

Store protected from moisture in a cool place.

**Sodium Bisulphite Solution:** Dissolve 10 g of *sodium bisulphite* in sufficient *water* to produce 30 ml.

Prepare immediately before use.

**Sodium Butanesulphonate;** 1-Butanesulphonic Acid Sodium Salt:  $\text{C}_4\text{H}_9\text{NaO}_3\text{S} = 160.17$

Chromatographic grade of commerce.

**Sodium Butanesulphonate, x M:** Solutions of any molarity xM may be prepared by dissolving 160.17x g of *sodium butanesulphonate* in sufficient *water* to produce 1000 ml.

**Sodium Carbonate:**  $\text{Na}_2\text{CO}_3 \cdot 10\text{H}_2\text{O} = 286.15$

Analytical reagent grade of commerce.

Transparent, colourless, rhombic crystals; odourless; efflorescent.

**Sodium Carbonate, Anhydrous:**  $\text{Na}_2\text{CO}_3 = 105.99$

Analytical reagent grade of commerce.

White, hygroscopic powder which loses not more than 1 per cent of its weight on heating to about 300°.

**Sodium Carbonate, x M:** Solutions of any molarity xM may be prepared by dissolving 286.15x g of *sodium carbonate* in sufficient *water* to produce 1000 ml.

**Sodium Carbonate Solution:** A 10.6 per cent w/v solution of *anhydrous sodium carbonate*.

**Sodium Carbonate Solution, Dilute:** A 10 per cent w/v solution of *sodium carbonate*.

**Sodium Chloride:** Of the Indian Pharmacopoeia.

**Sodium Chloride Injection:** Of the Indian Pharmacopoeia.

**Sodium Chloride Solution;** Brine: A saturated solution of *sodium chloride*.

**Sodium Citrate:** Of the Indian Pharmacopoeia.

**Sodium Cobaltinitrite;** Sodium Hexanitritocobaltate(III):  $\text{Na}_3\text{Co}(\text{NO}_2)_6 = 403.94$

Analytical reagent grade of commerce.

Orange-yellow powder.

**Sodium Cobaltinitrite Solution:** A 30 per cent w/v solution of *sodium cobaltinitrite*.

**Sodium 1-Decasulphonate:**  $\text{C}_{10}\text{H}_{22}\text{Na}_3\text{S} = 245.34$

Chromatographic reagent grade of commerce.

**Sodium 1-Decasulphonate Solution:** Dissolve 0.24 g of *sodium 1-decasulphonate* in 1000 ml of *water*.

**Sodium Diethyldithiocarbamate:**  $(\text{C}_2\text{H}_5)_2\text{NCSSNa} \cdot 3\text{H}_2\text{O} = 225.30$

Analytical reagent grade of commerce.

White or colourless crystals.

**Sodium Diethyldithiocarbamate solution:** A 0.1 per cent w/v solution of *sodium diethyldithiocarbamate*.

Prepare immediately before use.

**Sodium Dihydrogen Phosphate:** Of the Indian Pharmacopoeia.

**Sodium Dihydrogen Phosphate, x M:** Solutions of any molarity xM may be prepared by dissolving 156x g of *sodium dihydrogen phosphate* in sufficient *water* to produce 1000 ml.

**Sodium Ferrocyanide;** Sodium Hexacyanoferrate (II):  $\text{Na}_4\text{Fe}(\text{CN})_6 \cdot 10\text{H}_2\text{O} = 484.06$

General laboratory reagent grade of commerce.

Yellow Crystals or granules.

**Sodium Fluoride:** Of the Indian Pharmacopoeia.

**Sodium Formate:**  $\text{HCOONa} = 68.01$

General laboratory reagent grade of commerce.

White, deliquescent granules or crystalline powder; odour, slightly that of formic acid; mp about 253°.

Store protected from moisture.

**Sodium Heptanesulphonate;** 1-Heptanesulphonic Acid Sodium Salt:  $\text{C}_7\text{H}_{15}\text{NaO}_3\text{S} = 202.25$

Chromatographic reagent grade containing not less than 96.0 per cent of  $\text{C}_7\text{H}_{15}\text{NaO}_3\text{S}$ .

**Sodium Heptanesulphonate, 0.025 M:** Dissolve 5.056 g of *sodium heptanesulphonate* in sufficient *water* to produce 1000 ml.

**Sodium Heptanesulphonate Monohydrate:**  $\text{C}_7\text{H}_{15}\text{NaO}_3\text{S} \cdot \text{H}_2\text{O} = 220.26$

Chromatographic reagent grade of commerce containing not less than 96 per cent of  $\text{C}_7\text{H}_{15}\text{NaO}_3\text{S}$ , calculated with reference to the anhydrous substance.

Complies with the following tests.

**WATER** (2.3.43) — Not more than 8 per cent determined on 0.3 g.

**ASSAY** — Dissolve 0.15 g in 50 ml of *anhydrous glacial acetic acid*, determining the end-point potentiometrically (2.4.25). Carry out a blank titration. 1 ml of 0.1 M *perchloric acid* is equivalent to 0.02022 g of  $\text{C}_7\text{H}_{15}\text{NaO}_3\text{S}$ .

**Sodium Hexanesulphonate;** Hexanesulphonic Acid Sodium Salt:  $\text{C}_6\text{H}_{13}\text{NaO}_3\text{S} = 188.23$ .

Chromatographic reagent grade of commerce.

**Sodium Hexanesulphonate, 0.03 M;** Dissolve 5.65 g of *sodium hexanesulphonate* in sufficient *water* to produce 1000 ml.

**Sodium Hyaluronate:** Cut human umbilical cords, freed from blood and stored under *acetone*, into segments 2 cm long and wash with 10 volumes of *acetone*. Wash by soaking in three quantities, each of 10 volumes, of *water* for 2, 2 and 24 hours. Mince the cords, add an equal volume of *water*, adjust the pH to 2.0 with 2 M *hydrochloric acid* add 3 g of *pepsin* for each kg of cords, cover with a layer of *toluene* and incubate at 37



for 24 hours, maintaining the pH at 2.0. Adjust the pH to 7.4 by the cautious addition of a 40 per cent w/v solution of *sodium hydroxide*, add 5 g of *trypsin* for each kg of cords and incubate at 37° for 24 hours. Centrifuge the aqueous layer, decant the clear liquid, cool to 5°, adjust the pH to 2.0 with a mixture of equal volumes of *hydrochloric acid* and *water*, and add with stirring 2 volumes of *ethanol* (95 per cent). Separate the precipitate by centrifuging, suspend it in 300 ml of *water* for each kg of the cords and dialyse against running tap-water for 24 hours. To each litre for suspension add 660 ml of *chloroform* 340 ml of *amyl alcohol* and 200 ml of a solution containing 30 per cent w/v of *sodium acetate* and 16 per cent w/v of *glacial acetic acid* in *water*. Shake vigorously for 10 minutes, centrifuge and treat the separated aqueous phase repeatedly with further portions of the chloroform-amyl alcohol mixture until no precipitate is formed at the interface. To the aqueous phase add 2 volumes of *ethanol* (95 per cent), centrifuge dissolve the residue in *water*, dialyse against running tap-water for 24 hours and then against several changes of *water* for 24 hours; dry the product from the frozen state.

**Sodium Hyaluronate Stock Solution:** Prepare a stock solution to contain in each ml 500 mg of *sodium hyaluronate*, previously dried over *phosphorus pentoxide* under reduce pressure for 48 hours. Store at a temperature below 0° and use within 30 days. Do not keep the sodium hyaluronate over *phosphorus pentoxide* indefinitely.

**Sodium Hydroxide:** Of the Indian Pharmacopoeia.

**Sodium Hydroxide, x M:** Solutions of any molarity xM may be prepared by dissolving 40x g of *sodium hydroxide* in sufficient *water* to produce 1000 ml.

**Sodium Hydroxide, x M Ethanolic:** Solutions of any molarity xM may be prepared by dissolving 40x g of *sodium hydroxide* in sufficient *methanol* to produce 1000 ml.

**Sodium Hydroxide Solution:** A 20.0 per cent w/v solution of *sodium hydroxide*.

**Sodium Hydroxide Solution, Dilute:** A 5.0 per cent w/v solution of *sodium hydroxide*.

**Sodium Hypobromite Solution:** Mix 20 ml of 10 M *sodium hydroxide* and 500 ml of *water* in an ice-bath, add 5 ml of *bromine solution* and stir gently until solution is complete. Prepare immediately before use.

**Sodium Hypobromite Solution, Alkaline:** Dissolve 10 g of *sodium hydroxide* in 400 ml of *water*, add 5.5 ml of *bromine*, stir to dissolve and add sufficient *water* to produce 500 ml. Ascertain the strength of the solution by adding to 10 ml, 25 ml of *water*, 2 g of *potassium iodide* and 10 ml of *glacial acetic acid* and titrating the liberated iodine with 0.1 M *sodium thiosulphate* using *starch solution*, added toward the end of the titration, as indicator. 1 ml of 0.1 M *sodium thiosulphate* is equivalent to 0.0080 g of available bromine, Dilute the remainder

of the solution to contain 1.5 per cent w/v of available bromine; to 66 ml of the resulting solution add 20 ml of *sodium hydroxide solution* and sufficient *water* to produce 100 ml.

**Sodium Hypochlorite Solution:** General laboratory reagent grade of commerce containing not less than 10.0 per cent w/v and not more than 14.0 per cent w/v of available chlorine.

Clear, colourless to pale yellow liquid having odour of chlorine. It is affected by light and gradually deteriorates.

**ASSAY** — Transfer 1 ml in a glass-stoppered flask containing a solution of 3 g of *potassium iodide* in 100 ml of *water*, add 20 ml of *dilute acetic acid* and titrate the liberated iodine with 0.1 M *sodium thiosulphate* using *starch solution*, added towards the end of the titration, as indicator. 1 ml of 0.1 M *sodium thiosulphate* is equivalent to 0.003546 g of available chlorine.

Store protected from light preferably in a cool place.

**Sodium Hypochlorite Solution (3 per cent Cl):** Dilute 30 ml. of *sodium hypochlorite solution* to 100 ml. with *water* immediately before use. The solution contains not less than 2.5 per cent and not more than 3.0 per cent w/v of available chlorine determined by the following method.

**ASSAY** — Add to a flask, successively, 50 ml. of *water*; 1 g of *potassium iodide* and 12.5 ml. of 2 M *acetic acid*. Dilute 10 ml of the reagent under examination to 100 ml. with *water*, add 10 ml. of this solution to the flask and titrate with 0.1 M *sodium thiosulphate* using 1 ml of *starch solution*, added towards the end of the titration, as indicator.

1 ml of 0.1 M *sodium thiosulphate* is equivalent to 0.003546 g of available chlorine.

Store protected from light preferably in a cool place.

**Sodium Hypochlorite Solution (3.5 per cent Cl):** Dilute 35 ml of *sodium hypochlorite solution* to 100 ml with *water* immediately before use.

The solution contains approximately 3.5 per cent w/v of available chlorine determined by the method described under sodium hypochlorite solution (3 per cent Cl).

**Sodium Hypophosphite:**  $\text{NaH}_2\text{PO}_2 \cdot \text{H}_2\text{O} = 106.00$

General laboratory reagent grade of commerce.

Crystalline powder or colourless crystals; hygroscopic.

**Sodium Iodide:**  $\text{NaI} = 149.89$

Analytical reagent grade of commerce.

White crystals or granules; deliquescent.

**Sodium Lauryl Sulphate:** Of the Indian Pharmacopoeia.

**Sodium Lauryl Sulphate, x M:** Dissolve 288.4x g of *sodium lauryl sulphate*, in sufficient *water* to produce 1000 ml. Prepare immediately before use.

**Sodium Metabisulphite:** Of the Indian Pharmacopoeia.



**Sodium Molybdate:**  $\text{Na}_2\text{MoO}_4 \cdot 2\text{H}_2\text{O} = 242.00$

Analytical reagent grade of commerce.

Crystalline powder.

**Sodium Molybdotungstophosphate Solution:** Boil 350 ml of water, 50 g of sodium tungstate, 12 g of phosphomolybdic acid and 25 ml of phosphoric acid for 2 hours in a flask fitted with a reflux condenser. Cool and add sufficient water to produce 500 ml.

**Sodium 1,2-Naphthaquinone-4Sulphonate:**  $\text{C}_{10}\text{H}_5\text{NaO}_5\text{S} = 260.20$

General laboratory reagent grade of commerce.

Yellow or orange, crystalline powder.

**Sodium Nitrate:**  $\text{NaNO}_3 = 84.99$

Analytical reagent grade of commerce.

Colourless crystals or white, granular powder; deliquescent in humid air.

**Sodium Nitrite:**  $\text{NaNO}_2 = 68.99$

Analytical reagent grade of commerce containing not less than 97.0 per cent of  $\text{NaNO}_2$ , calculated with reference to the substance dried over anhydrous silica gel for 4 hours.

Colourless to slightly yellow crystals or white or slightly yellow, granular powder.

**Sodium Nitrite Solution:** A 10 per cent w/v solution of sodium nitrite.

Prepare immediately before use.

**Sodium Nitroprusside;** Sodium Pentacyanonitrosylferrate (III) Dihydrate:  $\text{Na}_2[\text{Fe}(\text{CN})_5(\text{NO})]_2 \cdot 2\text{H}_2\text{O} = 297.95$

Analytical reagent grade of commerce.

Reddish brown powder or crystals.

**Sodium Nitroprusside Carbonate Solution;** Sodium Nitroprusside Solution, Alkaline: Dissolve 1 g of sodium nitroprusside and 1 g of anhydrous sodium carbonate in sufficient water to produce 100 ml.

**Sodium Nitroprusside Solution:** A 1.0 per cent w/v solution of sodium nitroprusside.

Prepare immediately before use.

**Sodium Octanesulphonate;** Octanesulphonic Acid Sodium Salt:  $\text{C}_8\text{H}_{17}\text{NaO}_3\text{S} = 216.27$

General laboratory reagent grade of commerce.

**Sodium Octanesulphonate, 0.02 M:** Dissolve 4.33 g of sodium octanesulphonate in sufficient water to produce 1000 ml.

**Sodium Octyl Sulphate;** Sodium 4-Octyl Sulphate:  $\text{C}_8\text{H}_{17}\text{NaO}_4\text{S} = 232.27$

Chromatographic reagent grade of commerce.

**Sodium Oxalate:**  $\text{C}_2\text{Na}_2\text{O}_4 = 133.99$

Analytical reagent grade of commerce.

White, crystalline powder.

**Sodium Pentanesulphonate;** Sodium 1-Pentanesulphonate:  $\text{C}_5\text{H}_{11}\text{NaO}_3\text{S} = 174.19$

Chromatographic reagent grade of commerce.

**Sodium Perchlorate:**  $\text{NaClO}_4 \cdot \text{H}_2\text{O} = 140.46$

Analytical reagent grade of commerce.

White, deliquescent crystals.

**Sodium Periodate;** Sodium Metaperiodate:  $\text{NaIO}_4 = 213.89$

Analytical reagent grade of commerce containing not less than 99.0 per cent of  $\text{NaIO}_4$ .

**Sodium Periodate Solution:** Dissolve 1.07 g of sodium periodate in water and add 5 ml of 1 M sulphuric acid and sufficient water to produce 100 ml.

The solution should be freshly prepared.

**Sodium Peroxide:**  $\text{Na}_2\text{O}_2 = 77.98$

Analytical reagent grade of commerce.

Yellowish white, granular powder.

Store protect from light and moisture.

**CAUTION** — Protect from contact with organic or oxidisable substances.

**Sodium Phosphate:** Of the Indian Pharmacopoeia.

**Sodium Phosphate, Anhydrous:** Anhydrous Dibasic Sodium Phosphate; Anhydrous Disodium Hydrogen Phosphate;  $\text{Na}_2\text{HPO}_4 = 141.96$ .

Analytical reagent grade of commerce.

**Sodium Phosphate Solution:** Dissolve 12 g of clear crystals of sodium phosphate in water to make 100 ml.

**Sodium Phosphate, Tribasic;** Trisodium Phosphate; Trisodium Orthophosphate:  $\text{Na}_3\text{PO}_4 \cdot 12\text{H}_2\text{O} = 380.13$

Analytical reagent grade of commerce.

Colourless or white crystals.

**Sodium Potassium Tartrate;** Potassium Sodium Tartrate:  $\text{COONaCHOHCHOHCOOK} \cdot 4\text{H}_2\text{O} = 282.17$

Analytical reagent grade of commerce.

Colourless prismatic crystals or white, crystalline powder.

**Sodium Pyrophosphate:**  $\text{Na}_4\text{P}_2\text{O}_7 \cdot 10\text{H}_2\text{O} = 446.06$

Analytical reagent grade of commerce.

Colourless, slightly efflorescent crystals.

**Sodium Salicylate:** Of the Indian Pharmacopoeia.

**Sodium Salicylate Solution:** A 10.0 per cent w/v solution of *sodium salicylate*.

**Sodium silicate:**  $\text{Na}_2\text{SiO}_3 \cdot x\text{H}_2\text{O}$

Chemically pure grade of commerce.

White powder.

**Sodium Sulphate, Anhydrous:**  $\text{Na}_2\text{SO}_4 = 142.04$

Analytical reagent grade of commerce.

White crystalline powder or granules; hygroscopic

Complies with the following test.

**LOSS ON DRYING** — Not more than 0.5 per cent when dried at  $130^\circ$ .

**Sodium Sulphide:**  $\text{Na}_2\text{S} \cdot 9\text{H}_2\text{O} = 240.18$

Analytical reagent grade of commerce.

Colourless crystals or crystalline masses which turns yellow on storage; deliquescent.

**Sodium Sulphide Solution:** A 10.0 per cent w/v solution of *sodium sulphide*.

**Sodium Sulphite:**  $\text{Na}_2\text{SO}_3 \cdot 7\text{H}_2\text{O} = 252.15$

General laboratory reagent grade of commerce containing not less than 95.0 per cent of  $\text{Na}_2\text{SO}_3 \cdot 7\text{H}_2\text{O}$

White colourless crystals.

**Sodium Sulphite, Anhydrous:**  $\text{Na}_2\text{SO}_3 = 126.05$

Analytical reagent grade of commerce containing not less than 95 per cent of  $\text{Na}_2\text{SO}_3$ .

Small crystals or powder.

**Sodium Tartrate;** Sodium(+)-Tartrate:  $\text{C}_4\text{H}_4\text{O}_6 \cdot \text{Na}_2 \cdot 2\text{H}_2\text{O} = 230.08$

Analytical reagent grade of commerce.

Transparent crystals.

**Sodium Thioglycollate; Sodium Mercaptoacetate;** Mercaptoacetate Acid Sodium Salt:  $\text{SHCH}_2\text{COONa} = 114.09$

General laboratory reagent grade of commerce.

Hygroscopic crystals; odour, slight and characteristic.

**Sodium Thiosulphate:** Of the Indian Pharmacopoeia.

**Sodium Thiosulphate, x M:** Solutions of any molarity x M may be prepared by dissolving 248 x g of *sodium thiosulphate* and 2x g of *sodium carbonate* in sufficient *carbon dioxide-free water* to produce 1000 ml.

**Sodium Tungstate:**  $\text{Na}_2\text{WO}_4 \cdot 2\text{H}_2\text{O} = 329.86$

Analytical reagent grade of commerce.

Colourless crystals or white, crystalline powder.

**Sorbitol:** Of the Indian Pharmacopoeia.

**Squalane;** 2,6,10,15,19,23-Hexamethyltetracosane:  $\text{C}_{30}\text{H}_{62} = 422.81$

Gas chromatographic reagent grade of commerce.

Colourless oily liquid; refractive index, 1.451 to 1.453 at  $20^\circ$ ; wt. per ml, 0.811 to 0.813 g.

**Standard solution for the determination of water:** This solution is prepared, generally in acid conditions, from the element or a salt of the element whose minimum content is not less than 99.0 per cent. The quantity of per litre of solution is more than 0.995 g throughout the period, as long as the vial has not been opened. The starting material (element or salt) and the characteristic of the final solvent (nature and acidity etc) are mentioned on the label.

**Stannous Chloride;** Tin (II) Chloride:  $\text{SnCl}_2 \cdot 2\text{H}_2\text{O} = 225.63$

Analytical reagent grade of commerce.

Colourless crystals; contains not less than 97.0 per cent of  $\text{SnCl}_2 \cdot 2\text{H}_2\text{O}$ .

**ASSAY** — Dissolve 0.5 g in 15 ml of *hydrochloric acid* in a ground-glass stoppered flask and add 10 ml of *water* and 5 ml of *chloroform*. Titrate rapidly with 0.05 M *potassium iodate* until the *chloroform* layer is colourless.

1 ml of 0.05 M *potassium iodate* is equivalent to 0.02256 g of  $\text{SnCl}_2 \cdot \text{H}_2\text{O}$ .

**Stannous Chloride Solution:** May be prepared by either of the following two methods.

(1) Dissolve 330 g of *stannous chloride* in 100 ml of *hydrochloric acid* and add sufficient *water* to produce 1000 ml.

(2) Dilute 60 ml of *hydrochloric acid* with 20 ml of *water*, add 20 g of tin, heat gently until no more gas is evolved and add sufficient *water* to produce 100 ml. Store over a little of the undissolved tin remaining in the solution and protected from air.

**Stannous Chloride Solution AsT:** Stannous Chloride Solution, low in arsenic, commercially available or prepared from *stannous chloride solution* by adding an equal volume of *hydrochloric acid AsT*, reducing to the original volume by boiling and filtering through a fine-grain filter paper. It complies with the following test.

To 10 ml add 6 ml of *water* and 10 ml of *hydrochloric Acid AsT*, distil and collect 16 ml. To the distillate add 50 ml of *water*, 0.1 ml of the solution, 5 ml of 0.1 M *potassium iodide* and 5 g of *zinc AsT*. Use the apparatus and method described in Appendix 2.3.10. The stain produced on *mercuric chloride paper* is not more intense than that produced when the test is repeated with the addition of 0.1 ml of *arsenic standard solution (10 ppm As)*.

**Stannous Chloride Solution, Dilute:** Immediately before use, dilute 1 volume of *stannous chloride solution* with 10 volumes of 2 M *hydrochloric acid*.

**Starch:** Of the Indian Pharmacopoeia.

**Starch Iodide Solution;** Starch-Iodide Solution: Dissolve 0.5 g of *soluble starch* in 100 ml with *water* containing 0.5 g of *potassium iodide*.

**Starch, Soluble:** Analytical reagent grade of commerce.

A 2 per cent w/v solution in hot *water* is at most slightly opalescent and remains fluid on cooling.

**Starch Mucilage:** Triturate 0.5 g of *starch* or *soluble starch* with 5 ml of *water* and add, stirring continuously, to sufficient *water* to produce about 100 ml. Boil for a few minutes, cool and filter.

Produces a blue colour with free iodine in the presence of a soluble iodide.

It must be freshly prepared.

**Starch Solution:** Triturate 1 g of *soluble starch* with 5 ml of *water* and add, stirring continuously, to 100 ml of boiling *water* containing 10 mg of *mercuric iodide*.

Complies with the following test which should be carried out each time the reagent is used.

**SENSITIVITY TO IODINE** — Mix 1 ml of the reagent with 20 ml of *water*, add about 50 mg of *potassium iodide* and 0.05 ml of 0.005 M *iodine*; a blue colour is produced.

**Starch Solution, Iodide-free:** Triturate 1 g of *soluble starch* with 5 ml of *water* and add, stirring continuously, to 100 ml of boiling *water*.

Prepare immediately before use.

**Starch Substrate:** Stir an amount of *soluble starch* equivalent to 1.0 g of the dried substance in a beaker with 5 ml of *water*. Add, stirring continuously, to 75 ml of boiling *water*. Rinse the beaker with two quantities, each of 5 ml of *water*, add the washings to the hot starch solution and reboil for 2 minutes, stirring continuously. Cool to 25°, dissolve 5 g of *sodium chloride* in the starch solution and add sufficient *water* to produce 100 ml. Dilute 10.0 ml of this solution to 100.0 ml with *phosphate buffer solution pH 6.0* in the analysis of bacterial amylase and with *acetate buffer pH 5.0* in the analysis of fungal amylase. 1 ml of starch substrate contains 1.0 mg of dry soluble starch.

It must be freshly prepared.

**Stearic Acid:** Of the Indian Pharmacopoeia.

**Stearic Anhydride:** C<sub>36</sub>H<sub>70</sub>O<sub>3</sub> = 550.95

General laboratory reagent grade of commerce.

White, waxy crystalline flakes; mp, about 70°.

**Strontium Chloride:** SrCl<sub>2</sub>·6H<sub>2</sub>O = 266.62

Analytical reagent grade of commerce.

Colourless, odourless crystals or white granules; efflorescent in air; deliquescent in moist air.

**Styrene-Divinylbenzene Cation-Exchange Resin:** General chromatographic reagent grade of commerce suitable for use in column chromatography.

A strongly acidic, crossed-linked sulphonated resin containing about 2 per cent of divinylbenzene. White to light tan-coloured beads; relatively free flowing. Available in the hydrogen form in the 25- to 50-, 45- to 100-, and 80- to 270-mesh sizes or can be regenerated to the hydrogen form by treating with 5 per cent v/v *hydrochloric acid*. Insoluble in *water*, in *methanol* and in *acetonitrile*.

Complies with the following tests.

**MOISTURE CONTENT** — Transfer 10 to 12 ml of the resin (as received) to a flask and convert it completely to the hydrogen form by stirring with 150 ml of a 5 per cent v/v solution of *hydrochloric acid* for not less than 30 minutes. Decant the acid and wash the resin in the same manner with *water* until the wash *water* is neutral to litmus.

Transfer 5 to 7 ml of the fully regenerated and expanded resin to a glass-filtering crucible and remove only the excess surface water by very careful suction. Transfer the conditioned resin to a tared weighing bottle and weigh. Dry in a vacuum oven at a pressure of about 5.5 kPa at 105° for 16 hours. Transfer from the vacuum oven to a desiccator, cool to room temperature and weigh again. The loss in weight is between 75 and 83 per cent.

**TOTAL WET VOLUME CAPACITY** — Transfer 3 to 5 ml of the regenerated and undried resin obtained in the test for MOISTURE CONTENT to a 5-ml graduated cylinder and fill it with *water*. Remove any air bubbles from the resin bed with a stainless steel wire and settle the resin to its minimum volume by tapping the graduated cylinder. Record the volume of the resin.

Transfer the resin to a 400-ml beaker, add about 5 g of *sodium chloride* and titrate, stirring well, with 0.1 M *sodium hydroxide* to the blue end-point of *bromothymol blue*. Calculate the total wet volume capacity of the resin, which should be not less than 0.6 milliequivalents per ml, from the following expression.

$$\text{m.Eq. per ml} = \frac{\text{Net volume of NaOH(ml)} \times \text{Molarity}}{\text{ml of the resin}}$$

**MESH SIZE** — To 200 ml of *water* contained in a 1-litre wide-mouthed bottle or beaker add 150 ml of the resin under examination and allow to stand for at least 4 hours for complete swelling. Transfer 100 ml of the settled or swollen resin by means of a 100-ml graduated cylinder to the top screen of an

appropriate set of brass sieves (see Appendix 2.1.3). Wash the resin on each sieve thoroughly with a jet of *water* until the resin is completely graded, collecting the wash *water* in a suitable container. Wash the beads of the resin remaining on each sieve back into the 100-ml graduated cylinder and record the volume of resin settled on each sieve. Not less than 70 per cent of the resin is within the specified mesh size.

**Styrene-Divinylbenzene Cation-Exchange Resin, Strongly Acidic:** General chromatographic reagent grade of commerce (Dowex 50W-X8 is suitable).

**Substrate Plasma Deficient in Clotting Factor V:** Preferably use congenitally deficient plasma or, alternatively, prepare in the following manner. Separate the plasma from human blood collected in one-tenth of its volume of a 1.34 per cent w/v solution of *sodium oxalate* and incubate at 37° for 24 to 36 hours. This plasma should have a clotting time, when tested by the assay method given under *Clotting Factor V Solution*, of 70 to 100 seconds; if the clotting time is less than 70 seconds, incubate the plasma for a further 12 to 24 hours.

Store protected from light and moisture.

**Sucrose:** Of the Indian Pharmacopoeia.

**Sulphamic Acid:**  $\text{NH}_2\text{SO}_3\text{H} = 97.09$

General laboratory reagent grade of commerce.

White crystals or crystalline powder; mp, about 205°, with decomposition.

**4-Sulphamoylbenzoic Acid;** *p*-Carboxybenzene Sulphonamide; 4-Carboxybenzene Sulphonamide:  $\text{C}_7\text{H}_2\text{NO}_4\text{S} = 201.20$

General laboratory reagent grade of commerce.

Flat, shiny prisms; mp, about 291°.

**Sulphanilamide:**  $\text{H}_2\text{NC}_6\text{H}_4\text{SO}_2\text{NH}_2 = 172.21$

General laboratory reagent grade of commerce.

White or almost white, crystalline powder; mp, about 165°.

Store in a well-closed, light-resistant containers.

**Sulphanilic Acid:**  $\text{H}_2\text{NC}_6\text{H}_4\text{SO}_3\text{H} = 173.19$

**Sulphanilic Acid Solution, Diazotised:** Dissolve with warming, 0.9 g of *sulphanilic acid* in 9 ml of *hydrochloric acid* and dilute to 100 ml with *water*. Cool 10 ml of this solution in ice-bath and add 10 ml of an ice-cold 4.5 per cent w/v solution of *sodium nitrite*. Allow to stand in ice-bath for 15 minutes and immediately before use add 20 ml of *dilute sodium carbonate solution*.

**Sulphathiazole:** Of the Indian Pharmacopoeia.

**Sulphomolybdic Acid Solution:** Dissolve, with heating, 2.5 g of *ammonium molybdate* in 20 ml of *water*. Separately with care add 28 ml of *sulphuric acid* to 50 ml of *water* and cool.

Mix the two solutions and dilute to 100 ml with *water*.

Store in polyethylene containers.

**Sulphosalicylic acid;** 2-Hydroxy-5-sulphobenzoic acid:  $\text{C}_7\text{H}_6\text{O}_6\text{S}, 2\text{H}_2\text{O} = \text{Mol. Wt. } 254.2$

A white crystalline powder or crystals, very soluble in *water* and in *ethanol*.

mp, about 109°.

**Sulphur, Precipitated:** Precipitated grade of commerce.

Pale, greyish yellow or greenish yellow, soft powder.

**Sulphur Dioxide:**  $\text{SO}_2 = 64.06$

Laboratory cylinder grade of commerce.

Colourless gas; odour, acrid and penetrative.

**Sulphuric Acid:**  $\text{H}_2\text{SO}_4 = 98.07$

Where no molarity is indicated, use analytical reagent grade of commerce containing about 98 per cent w/w of *sulphuric acid* and about 18M in strength.

Colourless, corrosive oily liquid; evolves much heat when added to *water*; wt. per ml, about 1.84 g.

**Sulphuric Acid, x M:** Solutions of any molarity x M may be prepared by carefully adding 54x ml of *sulphuric acid* to an equal volume of *water* and diluting to 1000 ml with *water*.

**Sulphuric Acid, x per cent:** Mix x ml of *sulphuric acid* carefully with *water*, cool and adjust the volume to 100 ml to produce the specified percentage v/v of sulphuric acid.

**Sulphuric Acid, Dilute:** Contains approximately 10 per cent w/w of  $\text{H}_2\text{SO}_4$ .

Dilute 57 ml of *sulphuric acid* to 1000 ml with *water*.

**Sulphuric Acid, x M Ethanolic:** Solutions of any molarity xM may be prepared by carefully mixing 54x ml of *sulphuric acid* with *ethanol* (95 per cent), to produce 1000 ml.

**Sulphuric Acid, x per cent Ethanolic:** Mix x ml of *sulphuric acid* carefully with *ethanol* (95 per cent), cool and adjust the volume to 100 ml to produce the specified percentage v/v of ethanolic sulphuric acid.

**Sulphuric Acid-Formaldehyde Reagent:** Mix 2 ml of *formaldehyde solution* with 100 ml of *sulphuric acid*.

**Sulphuric Acid, x M Methanolic:** Solutions of any molarity xM may be prepared by carefully mixing 54x ml *sulphuric acid* with *methanol* to produce 1000 ml.

**Sulphuric Acid, x per cent Methanolic:** Mix x ml *sulphuric acid* carefully with *methanol*, cool and adjust the volume to 100 ml to produce the specified percentage v/v of methanolic sulphuric acid.

**Sulphuric Acid, Nitrogen-free:** A grade of commerce containing not less than 96.0 per cent w/w of *sulphuric acid* and complying with the following test.



**NITRATE** — To 5 ml of *water* add carefully 45 ml, cool to room temperature and add 8 mg of *N,N'*-diphenylbenzidine; the solution is colourless or very pale blue.

**Tannic Acid**; Tannin:  $C_7H_5O_4 = 1701.24$

General laboratory reagent grade of commerce.

Yellowish white or light brownish glistening scales, masses or impalpable powder.

Store protected from light.

**Tannic Acid Solution**: A 10.0 per cent w/v solution of *tannic acid*. Prepare immediately before use.

**Tartaric Acid**: Of the Indian Pharmacopoeia.

**Testosterone**:  $C_{19}H_{28}O_2 = 288.41$

General laboratory reagent grade of commerce.

mp, about 155°.

**Testosterone Acetate**:  $C_{21}H_{30}O_3 = 330.47$

General laboratory reagent grade of commerce.

**Testosterone Propionate**: Of the Indian Pharmacopoeia

**Tetrabutylammonium Bromide**:  $(C_4H_9)_4NBr = 322.38$

General laboratory reagent grade of commerce.

White, crystalline powder; mp, about 104°.

**Tetrabutylammonium Hydrogen Sulphate**:

$C_{16}H_{37}NO_4S = 339.54$

White, crystalline powder; mp, about 171°; contains not less than 97.0 per cent of  $C_{16}H_{37}NO_4S$ .

**ASSAY** — Dissolve about 0.170 g, accurately weighed, in 140 ml of *water* and titrate with 0.1 M *sodium hydroxide*. Perform a blank determination and make any necessary correction.

1 ml of 0.1 M *sodium hydroxide* is equivalent to 0.03395 g of  $C_{16}H_{37}NO_4S$ .

Complies with the following test.

**ABSORBANCE (2.4.1)** — Absorbance of a 5 per cent w/v solution in the range 240 nm to 300 nm, not more than 0.05.

**Tetrabutylammonium Hydroxide**:  $[CH_3(CH_2)_3]_4NOH = 259.48$

General laboratory reagent grade of commerce.

Wt. per ml, about 0.990 g; contains about 40 per cent w/v of  $C_{16}H_{37}NO_4S$ .

**Tetrabutylammonium Iodide**:  $[CH_3(CH_2)_3]_4NI = 369.37$

General laboratory reagent grade of commerce.

White or slightly coloured crystals or crystalline powder; mp, about 147°; contains not less than 98.0 per cent of  $C_{16}H_{36}IN$ .

Complies with the following test.

**SULPHATED ASH (2.3.18)** — Not more than 0.02 per cent.

**ASSAY** — Dissolve 1.2 g, accurately weighed, in 30 ml of *water* and add 50 ml to 0.1 M *Silver Nitrate* and 5 ml of 2 M *Nitric acid*. Titrate the excess of *silver nitrate* with 0.1 M *ammonium thiocyanate* using 2 ml of *ferric ammonium sulphate solution* as indicator.

1 ml of 0.1 M *silver nitrate* is equivalent to 0.03694 g of  $C_{16}H_{36}IN$ .

**1,1,2,2-Tetrachloroethylene**; Tetrachloroethane:  $C_2H_2Cl_4 = 167.84$

General laboratory reagent grade of commerce.

Heavy, mobile liquid; non-flammable; Odour, chloroform-like

**1-Tetradecane**; *n*-Tetradecane:  $CH_3(CH_2)_{12}CH_3 = 198.39$

General laboratory reagent grade of commerce.

Clear, colourless liquid; refractive index at 20°, about 1.429; bp, about 253°; wt. per ml, about 0.76 g; contains not less than 99.5 per cent of  $C_{14}H_{30}$ .

**Tetrahydrofuran**:  $CH_2(CH_2)_2CH_2O = 72.11$

Analytical reagent grade of commerce.

Clear, colourless, flammable liquid; bp, about 66; wt. per ml, about 0.888 g.

**NOTE** — Do not distil unless the tetrahydrofuran complies with the test for peroxides.

**PEROXIDES** — Place 8 ml of *starch iodide solution* in a 12 ml glass stoppered cylinder and about 1.5 cm in diameter. Fill completely with the reagent under examination, shake vigorously and allow to stand protected from light for 30 minutes; no colour is produced.

Tetrahydrofuran intended use for in spectrophotometry complies with the following additional requirement.

**TRANSMITTANCE** — Not less than 20 per cent at about 255 nm, 80 per cent at about 270 nm and 98 per cent at about 310 nm determined using *water* as the blank.

**Tetramethylammonium Chloride**:  $(CH_3)_4NCl = 109.60$

Colourless crystals; contains not less than 98.0 per cent of  $C_4H_{12}NCl$

**ASSAY** — Transfer about 200 mg, accurately weighed, to a beaker, add 50 ml of *water* and 10 ml of *dilute nitric acid*, swirl to dissolve, add 50 ml of 0.1 M *silver nitrate* and mix. Add 2 ml of *ferric ammonium sulphate* and 5 ml of *nitrobenzene*, shake and titrate the excess silver nitrate with 0.1 M *ammonium thiocyanate*.

1 ml of 0.1 M *silver nitrate* is equivalent to 0.01096 g of  $(CH_3)_4NCl$ .

**Tetramethylammonium Hydrogen Sulphate**:  $C_4H_{13}NO_4S = 171.21$

Chromatographic grade of commerce.

Tetramethylammonium Hydrogen Sulphate intended for use in high performance liquid chromatography complies with the following test.

**TRANS MITTANCE** — Not less than 50 per cent at about 200 nm and 90 per cent at about 220 nm determined using a 0.005 M solution.

**Tetramethylammonium Hydroxide:**  $C_4H_{13}NO = 91.15$

Commercially available as approximately 25 per cent w/v aqueous solution or as the crystalline pentahydrate with strong ammonia-like odour. Tetramethylammonium hydroxide is a stronger base than ammonia and absorbs carbon dioxide from air rapidly.

Store protected from moisture.

**ASSAY** — Weigh accurately a glass-stoppered flask containing about 15 ml. of water and add solution of tetramethylammonium hydroxide equivalent to about 200 mg. of  $(CH_3)_4NOH$  and weigh again. Add methyl red as indicator and titrate the solution with 0.1 M hydrochloric acid.

1 ml of 0.1 M hydrochloric acid is equivalent to 0.009115 g of  $C_4H_{13}NO$ .

**Tetramethylammonium Hydroxide solution;** Tetramethylammonium Hydroxide solution (10 per cent).

General laboratory reagent grade of commerce.

Clear, colourless or very pale liquid; odour; strongly ammoniacal; contains not less than 10.0 per cent w/w of  $C_4H_{13}NO$ .

**ASSAY** — To 1 g add 50 ml of water and titrate with 0.05 M sulphuric acid using methyl red solution as indicator.

1 ml of 0.05 M sulphuric acid is equivalent to 0.009115 g of  $C_4H_{13}NO$ .

**Tetramethylethyldiamine.**  $C_6H_{16}N_2 = \text{Mol. Wt. } 116.2$

A colourless liquid, miscible with water and alcohol.

$d_{20}^{20}$  about 0.78;  $[\alpha]_D^{20}$  about 1.418; bp. 121°.

***N,N,N',N'*-Tetramethyl-*p*-phenylenediamine Dihydrochloride;** *N,N,N',N'*-Tetramethyl-*p*-phenylenediammonium Dichloride:  $C_6H_4[N(CH_3)_2]_2 \cdot 2HCl = 237.17$

General laboratory reagent grade of commerce.

White or slightly tinted, crystalline powder.

**1,2,3,4-Tetraphenylcyclopenta-1,3-dienone;** 1,2,3,4-D-Tetraphenyl-1,3-Cyclopentadienone:  $C_{29}H_{22} = 370.49$ .

General laboratory reagent grade of commerce.

Off white to grey powder, darkens in storage; mp, about 178°.

**Tetrazolium bromide;** 3-(4,5-Dimethylthiazol-2-yl)-2,5-diphenyltetrazolium bromide:  $C_{18}H_{16}BrN_5S = \text{Mol. Wt. } 414.3$ .

**Thebaine (5R,9R,13S)-4,5Epoxy-3,6-dimethoxy-9'-methylmorphina-6, 8-diene:**  $C_{19}H_{21}NO_3 = 311.38$

General laboratory reagent grade of commerce.

White or pale yellow powder; mp, about 193°

**Theophylline:** Of the Indian Pharmacopoeia.

**Thiamazole;** Methimazole; 2-Mercapto-1-methylimidazole:  $C_4H_6N_2S = 114.17$

General laboratory reagent grade of commerce.

mp, about 145°.

**Thiazole orange:**  $C_3H_3NS = \text{Mol. Wt. } 85.1$

Colourless or pale yellow liquid.

**2-(2-Thienyl)acetic Acid;** 2-Thiopheneacetic acid:  $C_6H_6O_2S = 142.18$

General Laboratory reagent grade of commerce.

mp, about 65°.

**Thiocetamide:**  $CH_3CSNH_2 = 75.13$

General laboratory reagent grade of commerce.

White crystals or crystalline powder; mp, about 113°

**Thiocetamide Reagent:** Add 1 ml of a mixture of 15 ml of 1 M sodium hydroxide, 5 ml of water and 20 ml of glycerin (85 per cent) to 0.2 ml of thiocetamide solution, heat in a water-bath for 20 seconds cool and use immediately.

**Thiocetamide Solution:** A 4 per cent w/v solution of thiocetamide.

**Thioglycollic Acid;** Mercaptoacetic Acid:  $HSCH_2COOH = 92.12$

Analytical reagent grade of commerce.

Colourless or nearly colourless liquid; odour strong and unpleasant; wt. per ml about 1.33 g.

**Thiomersal:** Of the Indian Pharmacopoeia.

**Thiourea:**  $NH_2CSNH_2 = 76.12$

Analytical reagent grade of commerce.

Colourless, crystalline powder; odour, faint but characteristic; mp, about 178°.

**Thoron;** 1-*o*-Arsonophenylazo-2-naphthol-3,6-disulphonic Acid Sodium Salt; Thoronal:  $C_{16}H_{10}AsN_2Na_3O_{10}S_2$  (approx)

General laboratory reagent grade of commerce.

**Thrombin:** Dried human thrombin obtained from liquid plasma. It may be prepared by precipitation with suitable salts and organic solvents under controlled conditions of pH, ionic strength and temperature.

General laboratory reagent grade of commerce.

Yellowish white powder.

Store in sealed, sterile light-resistant containers under nitrogen, at a temperature below 25°.

**Thrombokinas Extract**; Thromboplastin Reagent: Extract 1.5 g of acetone-dried ox brain with 60 ml of *water* for 10 to 15 minutes at 50°, centrifuge for 2 minutes at 1500 rpm and decant the supernatant liquid. This extract will retain its activity for several days when stored in a refrigerator. It may contain 0.03 per cent w/v of *o-cresol* as an antimicrobial preservative.

**Thymine**: 5-Methylpyrimidine-2,4(1*H*,3*H*)-dione; C<sub>5</sub>H<sub>6</sub>N<sub>2</sub>O<sub>2</sub> = 126.1

Analytical reagent grade of commerce.

**Thymol**: Of the Indian Pharmacopoeia.

**Tin**; Granulated Tin Sn = 118.69

Analytical reagent grade of commerce.

Silver-white sticks or granules.

Complies with the following test.

**ARSENIC** — 0.1 g complies with the limit test for arsenic (2.3.10). (10 ppm).

**Titanium Trichloride**; Titanous Chloride; Titanium(III) Chloride: TiCl<sub>3</sub> = 154.24

General laboratory reagent grade of commerce.

Reddish violet crystals; mp, about 440°.

#### **Titanium Trichloride Solution**

General laboratory reagent grade of commerce containing about 15 w/v of TiCl<sub>3</sub> in *hydrochloric acid* (10 per cent w/v HCl). Store the solution in tightly-closed, glass-stoppered, light-resistant bottles.

**Toluene**; Methylbenzene: C<sub>6</sub>H<sub>5</sub>CH<sub>3</sub> = 92.14

Analytical reagent grade of commerce.

Clear, colourless liquid; odour, characteristic; bp, about 110°; wt. per ml, about 0.870 g.

**Toluene, Anhydrous**: Toluene which has been dried over anhydrous sodium sulphate.

**Toluene-3,4-dithiol-Zinc Complex**: C<sub>7</sub>H<sub>6</sub>S<sub>2</sub>Zn = 219.62

General laboratory reagent grade of commerce.

**Toluene, Prepared**: Toluene prepared by first shaking *toluene* with a small quantity of *water*, separating the excess *water* and distilling the *toluene*.

**Toluene-*o*-sulphonamide**; 2-Methylbenzene-sulphonamide; Toluene-2-sulphonamide: C<sub>7</sub>H<sub>9</sub>NO<sub>2</sub>S = 171.21

General laboratory reagent grade of commerce.

mp, about 156°.

**Toluene-4-sulphonamide**; Toluene-*p*-sulphonamide;

**4-Methylbenzenesulphonamide**: C<sub>7</sub>H<sub>9</sub>NO<sub>2</sub>S = 171.21

General laboratory reagent grade of commerce.

mp, about 136°

Complies with the following test.

**HOMOGENEITY** — Carry out the test for Related substances described in the monograph for Tolbutamide applying to the plate 5 ml of a 0.015 per cent w/v solution in *acetone*. The chromatogram shows only one spot.

**Triacetin**; Glycerol Triacetate:

CH<sub>2</sub>(COOCH<sub>3</sub>)CH(COOCH<sub>3</sub>)CH<sub>2</sub>(COOCH<sub>3</sub>) = 218.20

Clear, colourless or pale straw-coloured liquid; wt. per ml, about 1.156 g; contains not less than 95.0 per cent and not more than 99.0 per cent w/w of C<sub>9</sub>H<sub>14</sub>O<sub>6</sub>.

**ASSAY** — Carry out the method for the determination of esters (2.3.25).

1 ml of 0.5 *M ethanolic potassium hydroxide* is equivalent to 0.03637 g of C<sub>9</sub>H<sub>14</sub>O<sub>6</sub>.

**Triazolam**; **Chlorazam**; 8-Chloro-6-(2-chlorophenyl)-1-methyl-4*H*-[1,2,4]triazolo[4,3-*a*][1,4] benzodiazepine: C<sub>17</sub>H<sub>12</sub>C<sub>12</sub>N<sub>4</sub> = 343.22

General laboratory reagent grade of commerce.

Tan Crystals; mp, about 160°.

**Tributyl Phosphate**; Tributyl Orthophosphate:

[CH<sub>3</sub>(CH<sub>2</sub>)<sub>3</sub>]<sub>3</sub>PO<sub>4</sub> = 266.32

General laboratory reagent grade of commerce.

Clear, colourless liquid; refractive index at 20°, about 1.425; wt. per ml, about 0.977 g.

It should be washed 3 times before use with one-sixth of its volume of a solution containing 10 per cent w/v *sodium chloride* and 1.3 per cent w/v of *sodium dihydrogen phosphate*.

**Tricine**; N-[2-Hydroxy-1,1-bis(hydroxymethyl)ethyl]glycine: C<sub>6</sub>H<sub>13</sub>NO<sub>5</sub> = Mol. Wt. 179.2.

Use electrophoresis-grade reagent; mp, about 183°

**Trichloroacetic Acid**: Cl<sub>3</sub>COOH = 163.40

Analytical reagent grade of commerce.

Colourless, very deliquescent crystals or crystalline masses; odour, slight or pungent and characteristic; mp, about 56°.

Store protected from light.

**Trichloroacetic Acid Solution**: Dissolve 10 g of *trichloroacetic acid* in sufficient *water* to produce 100 ml.

**1,1,1-Trichloroethane**; Methyl Chloroform: CH<sub>3</sub>CCl<sub>3</sub> = 133.42

Analytical reagent grade of commerce.

Colourless, heavy liquid; bp, about 74°; wt. per ml, about 1.32 g.

**Triethanolamine:**  $N(\text{CH}_2\text{CH}_2\text{OH})_3 = 149.18$

General laboratory reagent grade of commerce.

Viscous, very hygroscopic, colourless liquid; odour, slightly ammoniacal; becomes brown on exposure to air and light; refractive index at 20°, about 1.484; wt. per ml, about 1.13 g.

Store protected from light.

**Triethylamine;** *N,N*-Diethylethanamine:  $(\text{C}_2\text{H}_5)_3\text{N} = 101.19$

General laboratory reagent grade of commerce.

Colourless liquid; odour, strongly ammoniacal; bp, about 90°; refractive index at 20°, about 1.401; wt. per ml, about 0.73 g.

Store protected from moisture.

**Triethylenediamine;** 1,4-Diazobicyclo[2.2.2]octane:  $\text{C}_6\text{H}_{12}\text{N}_2 = 112.17$

General laboratory reagent grade of commerce.

Hygroscopic crystals; sublimes readily at room temperature; mp, about 158°; bp, about 174°

Store in tightly-closed containers.

**Trifluoroacetic acid:**  $\text{C}_2\text{HF}_3\text{O}_2 = \text{Mol. Wt. } 114.0$

*Content.* Minimum 99 per cent of  $\text{C}_2\text{HF}_3\text{O}_2$ .

Liquid, miscible with acetone and with alcohol;  $d_{20}^{20}$ : about 1.53; bp, about 72°

Use a grade suitable for protein sequencing.

**Storage.** Store protected from moisture.

**Trimethylchlorosilane;** Chlorotrimethylsilane:  $(\text{CH}_3)_3\text{SiCl} = 108.65$

General laboratory reagent grade of commerce.

Clear, colourless liquid; bp, about 57°; refractive index at 20°, about 1.460; wt. per ml, about 0.86 g

**2,2,4-Trimethylpentane;** Iso-octane  $(\text{CH}_3)_3\text{CCH}_2\text{CH}(\text{CH}_3) = 114.23$

General laboratory reagent grade of commerce.

Colourless, liquid; flammable; bp, about 99°; refractive index at 20°, about 1.392; wt. per ml, about 0.694 g.

*2,2,4-Trimethylpentane* intended for use in spectrophotometry complies with following additional test.

**TRANSMITTANCE** — Not less than 98 per cent between 250 and 420 nm using *water* as the blank.

**Triphenylamine:**  $\text{C}_{18}\text{H}_{15}\text{N} = 245.32$

General laboratory reagent grade of commerce.

White, crystalline solid; mp, about 126°.

**Tris(hydroxymethyl)aminomethane;** Tromethamine; Trometamol; THAM; *Tris* (hydroxymethyl) methylamine; 2-Amino-2-(hydroxymethyl)-1,3-propanediol:  $\text{C}_4\text{H}_{11}\text{NO}_3 = 121.13$

Analytical reagent grade of commerce.

White crystals or crystalline powder; odour, characteristic; mp, about 170°

**Trypsin:** Freeze-dried, salt-free beef trypsin containing not less than 9000 benzoylarginine ethyl ester units per mg.

Proteolytic enzyme obtained by activation of tyrosinogen extracted from the pancreas of beef (*Bos taurus* Linn).

Store at a temperature not exceeding 4°.

**Tyramine;** 4-(2-Aminoethyl)phenol:  $\text{C}_8\text{H}_{11}\text{NO} = 137.18$ .

General laboratory reagent grade of commerce.

mp, about 162°.

**α-Tyrosine;** Tyrosine:  $\text{OHC}_6\text{H}_4\text{CH}_2\text{CH}(\text{NH}_2)\text{COOH} = 181.19$

General laboratory reagent grade of commerce.

White powder.

Complies with the following test.

**HO MOGENEITY** — Carry out the test for Related substances described in the monograph of Levodopa. The chromatogram shows only one spot.

**Undecenoic Acid:** Of the Indian Pharmacopoeia.

**Uranyl Acetate:**  $\text{U}_2(\text{CH}_3\text{CO})_2 \cdot 2\text{H}_2\text{O} = 424.15$

General laboratory reagent grade of commerce.

Bright yellow, crystalline powder; odour, slightly acetic.

**Urea:** Of the Indian Pharmacopoeia.

**Urease-active Meal:** General laboratory reagent grade of commerce. Complies with the following test.

**ACTIVITY** — 1 mg hydrolyses 3 mg of urea in 30 minutes at 37°

**Uridine;** 1-β-D-Ribofuranosyluracil; Uracil Riboside:  $\text{C}_9\text{H}_{12}\text{N}_2\text{O}_6 = 244.20$

Chromatographic grade of commerce.

Mp, about 165°.

**Valeric Acid;** *n*-Valeric Acid; Pentanoic Acid:  $\text{CH}_3(\text{CH}_2)_3\text{COOH} = 102.13$

General laboratory reagent grade of commerce.

Colourless liquid; odour, unpleasant; refractive index at 20°, about 1.409; bp, about 186°; wt. per ml, about 0.94 g.

**Vanillin:** Of the Indian Pharmacopoeia.

**Veratric Acid;** 3,4-Dimethoxybenzoic Acid;  $\text{C}_9\text{H}_{10}\text{O}_4 = 182.17$



General laboratory reagent grade of commerce.

mp, about 180°.

**Wash Solution pH 2.5:** To 500 ml of a 1 per cent v/v solution of *nitric acid* add *strong ammonia solution* until pH of the solution is 2.5. To the resulting solution add 10 ml of *buffer solution pH 2.5* and mix.

**Water:** Purified water of the Indian Pharmacopoeia.

**Water, Ammonia-free:** To 100 ml of *water* add 0.1 ml of *sulphuric acid* and distil discarding the first 10 ml and collecting the following 50 ml.

Complies with the following test.

To 50 ml, add 2 ml of alkaline potassium mercuri-iodide solution; no colour is produced.

**Water, Carbon Dioxide-free:** Water which has been boiled vigorously for a few minutes and protected from the atmosphere during cooling and storage.

**Water, Distilled:** Purified Water of the Indian Pharmacopoeia that has been prepared by distillation.

**Water for Injection:** Of the Indian Pharmacopoeia.

**Water for Injection, Sterile:** Of the Indian Pharmacopoeia.

**Water, Nitrate free:** To 100 ml of *water* add about 5 mg each of *potassium permanganate* and *barium hydroxide* and distil discarding the first 10 ml and collecting the following 50 ml.

**Water Purified:** Of the Indian Pharmacopoeia

**Wool Fat:** Of the Indian Pharmacopoeia

**Xanthidrol;** 9-Hydroxyxanthene; Xanthen-9-ol;  $C_{13}H_{10}O_2 = 198.22$

General laboratory reagent grade of commerce.

White to pale yellow powder; mp, about 123°; contains not less than 90.0 per cent of  $C_{13}H_{10}O_2$ .

Xanthidrol is also available as a solution in *methanol* containing 9.0 to 11.0 per cent w/v  $C_{13}H_{10}O_2$

**ASSAY** — In a 250-ml flask dissolve 0.3 g in 3 ml of *methanol* or use 3 ml of solution. Add 50 ml of *glacial acetic acid* and add, dropwise with shaking, 25 ml of a 2 per cent w/v solution of *urea*. Allow to stand for 12 hours, collect the precipitate on a sintered glass filter (16 mm), wash with 20 ml of *ethanol* (95 per cent), dry the precipitate at 105° and weigh.

1 g of the precipitate is equivalent to 0.9429 g of the  $C_{13}H_{10}O_2$ .

Store protected from light. If a methanolic solution is used, store in small, sealed ampoules and filter before use, if necessary.

**Xanthidrol Reagent:** Dissolve about 0.125 g of *xanthidrol* in 100 ml of *anhydrous glacial acetic acid*. Add 1 ml of

*hydrochloric acid* immediately before use.

**Xylene;** Mixture of o-, m- and p-isomers;  $C_6H_4(CH_3)_2 = 106.17$   
Analytical reagent grade of commerce.

Colourless, clear, flammable liquid; bp, about 140°; wt. per ml, about 0.855 g.

**Xylose:** Of the Indian Pharmacopoeia.

**Zinc:** Zn = 65.38

Analytical reagent grade of commerce.

Silver-white cylinders, granules, pellets or filings with a blue sheen; contains not less than 99.5 per cent of Zn.

Complies with the following test.

**ARSENIC** — 5 g complies with limit test for arsenic (2.3.10), using 15 ml of *hydrochloric acid AsT* and 25 ml *water* as the solvent (0.2 ppm).

**Zinc, Activated:** Cover a quantity of *zinc* with a solution containing 50 g of *chloroplatinic acid* per ml. Allow to stand for 10 minutes, wash, drain and dry immediately.

Complies with the following tests.

**ARSENIC** — to 5 g add 15 ml of *hydrochloric acid* and 25 ml of *water*. Add 0.1 ml of *stannous chloride solution AsT* and 5 ml of 0.1 M *potassium iodide*. Carry out the limit test for arsenic (2.3.10); no stain is produced on the mercuric chloride paper.

**ACTIVITY** — Repeat the test for **ARSENIC** using the same reagents and adding 1 ml of *arsenic standard solution* (1 ppm As); a distinct stain appears on the *mercuric chloride paper*.

**Zinc AsT:** Granulated zinc which complies with the following additional test. To 10 g add 15 ml of *stannous chloride solution AsT* and 5 ml of 0.1 M *potassium iodide*. Use the apparatus and method described in Appendix 2.3.10, but continue the action for 1 hour; no visible stain is produced on *mercuric chloride paper*. Repeat the test with the addition of 0.1 ml of *arsenic standard solution* (10 ppm); a faint but distinct stain is produced.

**Zinc Bis(diphenyldithiocarbamate):** General laboratory reagent grade of commerce.

mp, about 250°.

**Zinc and Sodium Carbonate Reagent:** Mix 1 part of *anhydrous sodium carbonate* and 2 parts of *zinc powder* and moisten the mixture with *anhydrous methanol*. Dry the mixture first on a water-bath and then at about 115° for a few hours.

Store in tightly-closed containers.

**Zinc Chloride:** Of the Indian Pharmacopoeia.

**Zinc Chloride-Formic Acid solution;** Zinc Chloride Solution: Dissolve 20 g of *zinc chloride* in 80 g of an 85 per cent w/v solution of *anhydrous formic acid*.

**Zinc Chloride Solution, Iodinated:** Dissolve 20 g of *zinc chloride* and 6.5 g of *potassium iodide* in 10.5 ml of *water*.

Add 0.5 g of iodine and shake for 15 minutes, filter if necessary.

Store protected from light.

**Zinc Dithiol Reagent:** Dissolve 0.2 g of *toluene-3,4-dithiol-zinc complex* in a 1 per cent w/v solution of *sodium hydroxide* containing 0.25 ml of *ethanol (95 per cent)*. Add 1 ml of *thioglycollic acid* and sufficient of the sodium hydroxide solution to produce 100 ml.

Prepare immediately before use.

**Zinc, Granulated:** Zn = 65.38

Bright silver-grey, metallic granules.

**Zinc Powder;** Zinc dust: Zn = 65.38

Analytical reagent grade of commerce.

Dense bluish grey powder; contains not less than 95.0 per cent of Zn.

**Zinc Shot:** Zn = 65.38

Analytical reagent grade of commerce.

Shot, 0.5 mm to 2.0 mm (about 8 to 30 mesh).

**Zinc Sulphate:** Of the Indian Pharmacopoeia.

**Zinc Sulphate, x M:** Solutions of any molarity x M may be prepared by dissolving 289x g of *zinc sulphate* in sufficient *water* to produce 1000 ml.

**Zinc Sulphate Solution:** A 0.011 per cent w/v solution of *zinc sulphate*; contains 0.025 mg of Zn in 1 ml.

**Zincon;** 1-(2-Hydroxy-5-sulphophenyl)-3-phenyl-5-(2-carboxyphenyl)formazan:  $C_{20}H_{16}N_4O_6S = 440.43$ .

Dark purple powder; mp, about 215°.

Complies with the following tests.

**SULPHATED ASH** (2.3.18) — Not more than 2.0 per cent.

**SENSITIVITY TO ZINC** — Add 0.2 ml of a 0.08 per cent w/v solution in *alkaline borate buffer pH 9.0* and 10 ml of *alkaline borate buffer pH 9.0* to 10 ml of a solution containing 0.0001 per cent zinc contained in a Nessler cylinder; a pale blue colour is observed when compared with a solution containing 10 ml of *water* in place of the zinc solution.

**Zincon Solution:** Dissolve 0.130 g of *zincon* in 2 ml of 1 M *sodium hydroxide* and dilute to 100 ml with *water*.

**Zinc Undecenoate:** Of the Indian Pharmacopoeia.

**Zirconyl Nitrate:** Approximately  $ZrO(NO_3)_2 + aq$

General laboratory reagent grade of commerce.

Usually contains about 44.5 per cent of  $ZrO_2$ .

**Zirconyl Nitrate Solution:** Dissolve 0.1 g of Zirconyl Nitrate in a mixture of 60 ml of hydrochloric acid and 40 ml of *water*.

### 4.3 Indicators and Indecator Test Paper

#### A. Indicators

In the test and assays of the Pharmacopoeia, indicators are required to indicate the completion of a chemical reaction in volumetric analysis or to indicate the pH of solutions. Indicators may be substituted for one another provided the colours change over approximately the same range of pH but in the event of doubt or dispute as to the equivalence of indicators for a particular procedure, the indicator specified in the individual monograph is alone authoritative.

Any solvent required in a determination or test in which an indicator is specified should be previously neutralized to the indicator unless a blank determination is performed or specified.

Given below are materials which are to be used as indicators and the manner in which solutions of indicators are to be prepared.

Table 1 lists the more commonly used pH indicators in ascending order of the lower limit of their range with the corresponding colour changes.

**Alizarin Red S;** CI 58005; Alizarin S; Mordant Red B; Sodium Alizarine Sulphonate; 9,10-Dihydro-3,4-dihydroxy-9,10-dioxo-2-anthranesulphonic Acid Monosodium Salt:  $C_{14}H_7NaO_7S \cdot H_2O = 360.27$

General laboratory reagent grade of commerce.

Yellowish brown or orange-yellow powder.

**Alizarin Red S Solution;** Alizarin S Solution: A 0.1 per cent w/v solution of *alizarin red S*. Complies with the following test.

**SENSITIVITY TO BARIUM** — To 5 ml of 0.05 M *sulphuric acid* add 5 ml of *water*, 50 ml of *acetate buffer pH 3.7* and 0.5 ml of the solution under examination. Add, dropwise, 0.05 M *barium perchlorate*; the colour changes from yellow to orange-red.

**Azo Violet;** Magneson; 4-(p-Nitrophenylazo)resorcinol:  $C_{12}H_9N_3O_4 = 259.22$

Red powder; mp, about 193°, with decomposition.

**Brilliant Green;** CI 42040; Malachite Green G; Basic Green 1:  $C_{27}H_{34}N_2O_4S = 482.64$

Technical Grade of commerce.

Small, glistening golden crystals.

**Brilliant Green Solution;** A 0.5 per cent w/v solution of *brilliant green* in *glacial acetic acid*.

**Bromocresol Green;** Bromocresol Blue; 4,4'-(3H-2,1-Benzoxathiol-3-ylidene)bis(2,6-dibromo-*m*-cresol) *S,S*-dioxide:  $C_{21}H_{14}Br_4O_5S = 698.01$

White or pale buff-coloured powder.

TABLE 1-pH ranges and colour changes of indicators

Indicator	pH range	Colour change
Cresol Red	0.2 to 1.8 and 7.2 to 8.8	Red to Yellow  Yellow to Red
Metacresol Purple	0.5 to 2.5 and 7.5 to 9.2	Red to Yellow  Yellow to Violet
Thymol Blue	1.2 to 2.8 and 8.0 to 9.6	Red to yellow  Yellow to Violet-blue
Metanil Yellow	1.2 to 2.3	Magenta to Yellow
Quinaldine Red	1.4 to 3.2	Colourless to Red
Dimethyl Yellow	2.8 to 4.6	Red to Yellow
Bromophenol Blue	2.8 to 4.6	Yellow to Blue-violet
Methyl Orange	2.9 to 4.0	Red to Yellow
Congo Red	3.0 to 5.0	Blue to Red
Bromocresol Green	3.6 to 5.2	Yellow to Blue
Methyl Red	4.2 to 6.3	Red to Yellow
Litmus	5.0 to 8.0	Red to Blue
Bromocresol Purple	5.2 to 6.8	Yellow to Blue-violet
Bromothymol Blue	6.0 to 7.6	Yellow to Blue
Neutral Red	6.8 to 8.0	Red to Orange
Phenol Red	6.8 to 8.4	Yellow to Red
Phenolphthalein	8.3 to 10.0	Colourless to Red
Thymolphthalein	9.3 to 10.5	Colourless to Blue
Titan Yellow	12.0 to 13.0	Yellow to Red

**Bromocresol Green Reagent:** Prepare a phosphate buffer solution by dissolving 43.0 g of *sodium dihydrogen phosphate* and 2.0 g of *anhydrous sodium phosphate* in sufficient *water* to make 1000 ml. Dissolve 0.2 g of *bromocresol green* in 30 ml of *water* and 6.5 ml of 0.1 M *sodium hydroxide*. Dilute to 500 ml with the phosphate buffer solution, mix and adjust the pH to 4.6 with 0.1 M *hydrochloric acid*.

**Bromocresol Green Solution:** Dissolve 50 mg of *bromocresol green* in 0.72 ml of 0.1 M *sodium hydroxide* and 20 ml of *ethanol (95 per cent)*. After solution is effected, add sufficient *water* to produce 100 ml.

Complies with the following test.

**SENSITIVITY** — A mixture of 0.2 ml of the solution and 100 ml of *carbon dioxide-free water* is blue. Not more than 0.2 ml of 0.02 M *hydrochloric acid* is required to change the colour of the solution to yellow.

**Bromocresol Purple;** 4,4'-(3H-2,1-Benzoxathiol-3-ylidene) bis(6-bromo-*o*-cresol) *S,S*-dioxide:  $C_{21}H_{16}Br_2O_5S = 540.23$

White to pink, crystalline powder.

**Bromocresol Purple Solution:** Dissolve 50 mg of *bromocresol purple* in 0.92 ml of 0.1 M *sodium hydroxide* and 20 ml of *ethanol (95 per cent)*. After solution is effected, add sufficient *water* to produce 100 ml.

Complies with the following test.

**SENSITIVITY** — A mixture of 0.2 ml of the solution and 100 ml of *carbon dioxide-free water* to which 0.05 ml of 0.02 M *sodium hydroxide* has been added is bluish violet. Not more than 0.2 ml of 0.02 M *hydrochloric acid* is required to change the colour to yellow.

**Bromocresol Purple Solution, Phosphate-buffered:** Dissolve 43 g of *potassium dihydrogen phosphate* and 5 g of *sodium phosphate* in *water* to make 1000 ml. Adjust the pH of the solution to  $5.3 \pm 0.1$ , if necessary (Solution A). Dissolve 0.4 g of *bromocresol purple* in 30 ml of *water*, add 6.3 ml of 0.1 M *sodium hydroxide* and dilute with *water* to make 500 ml (Solution B). Shake equal volumes of solution A, solution B and *chloroform* in a separator, allow the layers to separate and discard the *chloroform*. If appreciable colour is extracted by the *chloroform*, repeat with additional quantities of *chloroform* until no further colour is extracted.

**Bromophenol Blue;** 4,4'-(3H-2,1-Benzoxathiol-3-ylidene)-bis(2,6-dibromophenol) *S,S*-dioxide:  $C_{19}H_{10}Br_4O_5S = 669.96$

Pinkish crystals.

**Bromophenol Blue Solution;** Strong Bromophenol Blue Solution; Ethanolic Bromophenol Blue Solution: Dissolve 0.1 g of *bromophenol blue* with gentle heating in 1.5 ml of 0.1 M *sodium hydroxide* and 20 ml of *ethanol (95 per cent)* and add sufficient *water* to produce 100 ml.

Complies with the following test.

**SENSITIVITY** — A mixture of 0.05 ml of the solution and 20 ml of *carbon dioxide-free water* to which 0.05 ml of 0.1 M *hydrochloric acid* has been added is yellow. Not more than 0.1 ml of 0.1 M *sodium hydroxide* is required to change the colour to bluish violet.

**Bromophenol Blue Reagent:** Dissolve 50 mg of *bromophenol blue* with gentle heating in 3.73 ml of 0.02 M *sodium hydroxide* and dilute to 100 ml with *water*.

**Bromothymol Blue;** 4,4'-(3H-2,1-Benzoxathiol-3-ylidene)-bis(2-bromothymol) *S,S*-dioxide:  $C_{27}H_{28}Br_2O_5S = 624.39$ .

Cream-coloured powder.

**Bromothymol Blue Solution;** Aqueous Bromothymol Blue Solution: Dissolve 50 mg of *bromothymol blue* in 4 ml of 0.02 M sodium hydroxide and 20 ml of *ethanol* (95 per cent). After solution is effected, add sufficient *water* to produce 100 ml.

Complies with the following test.

**SENSITIVITY** — A mixture of 0.3 ml of the solution and 100 ml of *carbon dioxide-free water* is yellow. Not more than 0.1 ml of 0.02 M sodium hydroxide is required to change the colour to blue.

**Calcon;** CI 15705; Solochrome Dark Blue; Mordant Black 17; Sodium 2-hydroxy-1-(2-hydroxy-1-naphthylazo)-naphthalene-4-sulphonate:  $C_{20}H_{13}N_2NaO_5S = 416.38$

General laboratory reagent grade of commerce.

Brownish black powder with a violet sheen. Gives a purple-red colour with calcium ions in alkaline solution. When metal ions are absent, for example, in the presence of an excess of disodium edetate, the solution is blue.

**Calcon Mixture:** A mixture of 1 part of *calcon* with 99 parts of freshly ignited *anhydrous sodium sulphate*.

Complies with the following test.

**SENSITIVITY** — Dissolve 0.1 g in 2.5 ml of *water*. To 1 ml of the solution add 50 ml of *water*, 10 ml of 1 M sodium hydroxide and 1 ml of a 1 per cent w/v solution of *magnesium sulphate*; the solution is blue. Add 0.1 ml of a 0.15 per cent w/v solution of *calcium chloride*; the solution becomes violet and on subsequent addition of 0.1 ml of 0.01 M disodium edetate turns to blue again.

**Congo Red;** CI 22120; Disodium (4,4'-biphenylbis-2,2-azo) bis(1-aminonaphthalene-4-sulphonate):  $C_{32}H_{22}N_6Na_2O_6S_2 = 696.66$

Dark red or reddish brown powder. Decomposes on exposure to acid fumes.

**Congo Red Fibrin;** Soak washed and shredded *fibrin* overnight in a 2 per cent w/v solution of *congo red* in *ethanol* (90 per cent), strain, wash the product with *water* and store under *ether*.

**Cresol Red;** 4,4'-(3H-2,1-Benzoxathiol-3-ylidene) di-*o*-cresol S,S-dioxide:  $C_{21}H_{18}O_5S = 382.44$

Red brown powder.

**Cresol Red Solution:** Warm 0.1 g of *cresol red* in a mixture of 2.65 ml of 0.1 M sodium hydroxide and 20 ml of *ethanol* (95 per cent). After solution is effected, add sufficient *water* to produce 100 ml.

Complies with the following test.

**SENSITIVITY** — A mixture of 0.1 ml of the solution and 100 ml of *carbon dioxide-free water* to which 0.15 ml of 0.02 M sodium

*hydroxide* has been added is purplish red. Not more than 0.15 ml of 0.02 M hydrochloric acid is required to change the colour to yellow.

**Crystal Violet;** CI 42555; Basic Violet 3; Hexamethyl-*p*-rosaniline Chloride:  $C_{25}H_{30}ClN_3 = 407.98$

When used for titrations in non-aqueous media, changes from violet (basic) through blue-green (neutral) to yellowish green (acidic).

**Crystal Violet Solution:** A 0.5 per cent w/v solution of *crystal violet* in *anhydrous glacial acetic acid*.

Complies with the following test.

**SENSITIVITY** — A mixture of 0.1 ml of the solution and 50 ml of *anhydrous glacial acetic acid* is bluish purple. Add 0.1 ml of 0.1 M perchloric acid; the solution turns blue-green.

**Dimethyl Yellow;** CI 11020; 4-Dimethylaminoazobenzene:

$C_{14}H_{15}N_3 = 225.29$

Yellow crystalline leaflets; mp, about 116°.

Complies with the following test.

**HOMOGENEITY** — Carry out the method for *thin-layer chromatography* (2.4.17), using *silica gel G* as the coating substance and *dichloromethane* as the mobile phase. Apply to the plate 10 ml of a 0.01 per cent w/v solution in *dichloromethane*. The chromatogram shows only one spot.

**Dimethyl Yellow Solution:** A 0.2 per cent w/v solution of *dimethyl yellow* in *ethanol* (90 per cent).

Complies with the following test.

**SENSITIVITY** — A solution containing 2 g of *ammonium chloride* in 25 ml of *carbon dioxide-free water*, to which is added 0.1 ml of the dimethyl yellow solution, is yellow. Not more than 0.1 ml of 0.1 M hydrochloric acid is required to change the colour to red.

**Dimethyl Yellow-Oracet Blue B Solution;** Dimethyl Yellow-Solvent Blue 19 Solution: Dissolve 15 mg of *dimethyl yellow* and 15 mg of *oracet blue B* in *chloroform* and dilute to 500 ml with *chloroform*.

**Eosin;** CI 45380; Acid red 87:  $C_{20}H_6Br_4Na_2O_5 = 691.86$

General laboratory reagent grade of commerce.

Red powder.

**Eosin Solution:** A 0.5 per cent w/v solution of *eosin* in *water*.

**Eriochrome Black T;** CI 14645; Mordant Black 11; Solochrome Black; Sodium 1-(1-hydroxy-2-naphthylazo)-5-nitro-2-naphthol-4-sulphonate:  $C_{20}H_{12}N_3NaO_7S = 461.38$

General laboratory reagent grade of commerce.

Brownish black powder having a faint, metallic sheen. Gives a red colour with calcium, magnesium, zinc and certain other



metals in alkaline solutions. When metal ions are absent, for example in the presence of an excess of disodium edetate, the solution is blue.

Store protected from light and moisture.

Complies with the following test.

**SENSITIVITY** — To 10 ml of a 1 in 200,000 solution in a mixture of equal parts of *methanol* and *water* add a 1 per cent w/v solution of *sodium hydroxide* until the pH is 10; the solution is pure blue in colour and free from cloudiness. Add 0.01 ml of 0.05 M *magnesium sulphate*; the colour of the solution changes to red-violet, and on adding more 0.05 M *magnesium sulphate*, the solution becomes wine-red in colour.

**Eriochrome Black T Mixture**; Eriochrome Black T Triturate; Mordant Black 11 Mixture: A mixture of 1 part of *eriochrome black T* and 99 parts of *sodium chloride*.

Store protected from light and moisture.

Complies with the following test.

**SENSITIVITY** — Dissolve 50 mg in 100 ml of *water*, a brownish violet colour is produced. Add 0.3 ml of 6 M *ammonia*; the colour changes to blue. Add 0.1 ml of a 1 per cent w/v solution of *magnesium sulphate*; the colour changes to violet.

**Eriochrome Black T Solution**; Mordant Black 11 Solution: Dissolve 0.2 g of *eriochrome black T* and 2 g of *hydroxylamine hydrochloride* in sufficient *methanol* to produce 50 ml.

Prepare immediately before use.

**Fast Blue B Salt**; CI 37235:  $C_{14}H_{12}Cl_2N_4O_2 = 339.18$

General laboratory reagent grade of commerce.

Dark green powder, stabilised by the addition of zinc chloride.

Store protected from moisture in a cold place.

**Ferriin Solution**; Ferriin Sulphate Solution; Tris-(1,10-phenanthroline)ferrous Sulphate Complex: Dissolve 0.7 g of *ferrous sulphate* and 1.5 g of 1,10-phenanthroline *hydrochloride* in 70 ml of *water* and add sufficient *water* to produce 100 ml.

Complies with the following test.

**SENSITIVITY** — Add 0.1 ml of the solution and 0.15 ml of *osmic acid solution* to 50 ml of 1 M *sulphuric acid*. Add 0.1 ml of 0.1 M *ceric ammonium nitrate*; the colour changes from red to light blue.

**Indophenol Blue**; CI 49700:  $C_{18}H_{26}N_2O = 276.34$

General laboratory reagent grade of commerce.

Dark purple powder.

Complies with the following test.

**HOMOGENEITY** — Carry out the method for *thin-layer chromatography* (2.4.17), using *silica gel G* as the coating

substance and *dichloromethane* as the mobile phase. Apply to the plate 10 ml of a 0.01 per cent w/v solution in *dichloromethane*. After removal of the plate, allow it to dry in air. The chromatogram shows only one spot, but a stain may remain at the point of origin.

**Litmus**: Fragments of blue pigment prepared from various species of *Rocella*, *Lecanora* or other lichens. It has a characteristic odour. Partly soluble in *water* and in *ethanol*.

**NOTE** — *Litmus is unsuitable for determining the pH of alkaloids, carbonates and bicarbonates.*

**Litmus Solution**: Boil 25 g of coarsely powdered *litmus* with 100 ml of *ethanol* (90 per cent) under a reflux condenser for 1 hour and discard the clear liquid. Repeat this operation with two quantities, each of 75 ml of *ethanol* (90 per cent). Digest the extracted *litmus* with 250 ml of *water* and filter.

**Metacresol Purple**; 4,4'-(3H-2,1-Benzoxanthiol-3-ylidene)-di-*m*-cresol *S,S*-dioxide:  $C_{21}H_{16}O_5S = 380.40$

General laboratory reagent grade of commerce.

**Metalphthalein**; Phthalein Purple:  $C_{32}H_{32}N_2O_{12} + aq$

Creamy white brown powder.

Complies with the following test.

**SENSITIVITY** — Dissolve 10 mg in 1 ml of *strong ammonia solution* and dilute to 100 ml with *water*. To 5 ml of the solution add 95 ml of *water*, 4 ml of *strong ammonia solution*, 50 ml of *ethanol* (95 per cent) and 0.2 ml of 0.1 M *barium chloride*; the solution is bluish violet. Add 0.24 ml of 0.05 M *disodium edetate*; the solution becomes colourless.

**Metanil Yellow**; CI 13065;

Sodium 4-anilinoazobenzene-3-sulphonate:  $C_{18}H_{14}N_3NaO_3S = 375.40$

Brownish yellow powder; soluble in *water* and in *ethanol*; slightly soluble in *acetone* and in *ether*.

**Metanil Yellow Solution**: A 0.1 per cent w/v solution of *metanil yellow* in *methanol*.

Complies with the following test.

**SENSITIVITY** — Add 0.1 ml of the solution to 50 ml of *anhydrous glacial acetic acid*; the mixture is pinkish red. Add 0.05 ml of 0.1 M *perchloric acid*; the colour changes to violet.

**Methyl Orange**; CI 13025; Sodium 4-dimethylaminoazobenzene-4-sulphonate:  $C_{14}H_{14}N_3NaO_3S = 327.34$

Orange-yellow powder or crystalline scales; Sparingly soluble in hot *water*; slightly soluble in *water*; practically insoluble in *ethanol*.

**Methyl Orange Solution**: Dissolve 0.1 g of *methyl orange* in 80 ml of *water* and add sufficient *ethanol* (95 per cent) to produce 100 ml.

Complies with the following test.

**SENSITIVITY** — A mixture of 0.1 ml of the solution and 100 ml of *carbon dioxide-free water* is yellow. Note more than 0.1 ml of 0.1 M *hydrochloric acid* is required to change the colour to red.

**Methyl Red**; CI 13020; 2-(4-Dimethylaminophenylazo)-benzoic Acid:  $C_{15}H_{15}N_3O_2 = 269.30$

Dark red powder or violet crystals; mp, about 182°; soluble in *ethanol*; practically insoluble in *water*.

**Methyl Red- Methylene Blue Solution**; Methyl Red Mixed Solution: Dissolve 0.1 g of *methyl red* and 50 mg of *methylene blue* in 100 ml of *ethanol* (95 per cent). Colour changes from reddish violet to green (pH range, 5.2 to 5.6).

**Methyl Red Solution**: Dissolve 50 mg of *methyl red* in a mixture of 1.86 ml of 0.1 M *sodium hydroxide* and 50 ml of *ethanol* (95 per cent). After solution is effected, add sufficient *water* to produce 100 ml.

Complies with the following test.

**SENSITIVITY** — A mixture of 0.1 ml of the solution, 100 ml of *carbon dioxide-free water* and 0.05 ml of 0.02 M *hydrochloric acid* is red. Not more than 0.1 ml of 0.02 M *sodium hydroxide* is required to change the colour to yellow.

**Methylenebisacrylamide**.  $C_7H_{10}N_2O_2 = \text{Mol. Wt. } 154.2$

A fine, white or almost white powder, slightly soluble in *water*; soluble in *alcohol*.

mp. it melts with decomposition at a temperature above 300°.

**Methylene Blue**; CI 52015; Basic Blue 9; 3,7-Bis-(dimethylamino)phenothiazin-5-ium chloride:

$C_{16}H_{18}ClN_3S \cdot xH_2O = 319.86$  (anhydrous)

Redox indicator grade suitable for biological work.

Dark green or brown crystals with bronze lustre or crystalline powder; hygroscopic; soluble in *water* and in *chloroform*; sparingly soluble in *ethanol*; insoluble in *ether*.

**Methylene Blue Solution**: Dissolve 150 mg of *methylene blue* in 100 ml of *ethanol* (95 per cent) and dilute with *ethanol* (95 per cent) to produce 250 ml.

**Methyl Orange-Xylene Cyanol FF Solution**: Dissolve 0.1 g of *methyl orange* and 0.26 g of *xylene cyanol FF* in 50 ml of *ethanol* (95 per cent) and add sufficient *water* to produce 100 ml.

**Methyl Thymol Blue**; 3H-2,1-Benzoxathiol-3-ylidenebis-(6-hydroxy-5-isopropyl-2-methyl-*m*-phenylene) methylene-nitrilo]tetraacetic acid *S*, *S*-dioxide Tetrasodium salt:  $C_{37}H_{40}N_2Na_4O_{13}S = 844.75$

General laboratory reagent grade of commerce.

Produces a blue colour with calcium ions in alkaline solution. When metal ions are absent, for example, in the presence of an excess of disodium edetate, the solution is grey.

**1-Naphtholbenzein**;  $\alpha$ -Naphtholphthalein; Phenylbis-(4-hydroxynaphthyl)methenol:  $C_{27}H_{20}O_3 = 392.50$   
Brownish red powder or shiny brownish black crystals .

**1-Naphtholbenzein Solution**;  $\alpha$ -Naphtholbenzein Solution: A 0.2 per cent w/v solution of 1-naphtholbenzein in *anhydrous glacial acetic acid*.

Complies with the following test.

**SENSITIVITY** — Add 0.25 ml to 50 ml of *anhydrous glacial acetic acid*. Not more than 0.05 ml of 0.1 M *perchloric acid* is required to change the colour of the solution from brownish yellow to green.

**Neutral Red**; CI 50040; Basic Red 5; 3-Amino-7-dimethylamino-2-methylphenazine Monohydrochloride:  $C_{15}H_{16}N_4 \cdot HCl = 288.78$   
Reddish to olive green coarse powder; sparingly soluble in *ethanol* and in *water*.

**Neutral Red Solution**: A 0.1 per cent w/v solution of *neutral red* in *ethanol* (50 per cent).

**Nile Blue A**; CI 51180; 5-Amino-9-diethylaminobenzo[ $\alpha$ ]-phenoxazinylium Hydrogen Sulphate:  $C_{20}H_{21}N_3O_5S = 415.47$

Green, crystalline powder with a bronze lustre.

Complies with the following test.

**LIGHT ABSORPTION** — A 0.0005 per cent w/v solution in *ethanol* (50 per cent) exhibits a maximum at about 640 nm (2.4.7).

**Nile Blue A Solution**: A 1 per cent w/v solution of *nile blue A* in *anhydrous glacial acetic acid*.

Complies with the following test.

**SENSITIVITY** — A solution containing 0.25 ml in 50 ml of *anhydrous glacial acetic acid* is blue. Not more than 0.1 ml of 0.1 M *perchloric acid* is required to change the colour of the solution to bluish green.

Colour changes from blue to red (pH range, 9.0 to 13.0).

**Oracet Blue B**; Solvent Blue 19: A mixture of 1-methylamino-4-anilinoanthraquinone,  $C_{21}H_{16}N_2O_2$ , and 1-amino-4-anilinoanthraquinone,  $C_{20}H_{14}N_2O_2$ .

When used for titration in non-aqueous media, it changes from blue (basic) through purple (neutral) to pink (acidic).

**Oracet Blue B Solution**: A 0.5 per cent w/v solution of *oracet blue B* in *anhydrous glacial acetic acid*.

**Phenol Red**; Phenolsulphonphthalein; 4,4'-(3H-2,1-Benzoxathiol-3-ylidene)diphenol *S,S*-dioxide:  $C_{19}H_{14}O_5S = 354.39$

Bright to dark red crystalline powder; freely soluble in solutions of alkali carbonates and hydroxides; slightly soluble in *ethanol* (95 per cent); very slightly soluble in *water*.

**Phenol Red Solution:** Dissolve 0.1 g of *phenol red* in 2.82 ml of 0.1 M *sodium hydroxide* and 20 ml of *ethanol* (95 per cent). After solution is effected, add sufficient *water* to produce 100 ml.

Complies with the following test.

**SENSITIVITY** — A mixture of 0.1 ml of the solution and 100 ml of *carbon dioxide-free water* is yellow. Not more than 0.1 ml of 0.02 M *sodium hydroxide* is required to change the colour of the solution to reddish violet.

**Phenol Red Reagent:**

**SOLUTION I** — Dissolve 33 mg of *phenol red* in 1.5 ml of 2 M *sodium hydroxide* and dilute to 100 ml with *water*.

**SOLUTION II** — Dissolve 25 mg of *ammonium sulphate* in 235 ml of *water*, add 105 ml of 2 M *sodium hydroxide* and 135 ml of 2 M *acetic acid*.

Add 25 ml of solution I to solution II. If necessary, adjust the pH of the mixture to 4.7.

**Phenolphthalein:** Of the Indian Pharmacopoeia.

**Phenolphthalein Solution:** A 1.0 per cent w/v solution of *phenolphthalein* in *ethanol* (95 per cent).

**Phenolphthalein Solution, Dilute:** Dissolve 0.1 g of *phenolphthalein* in 80 ml of *ethanol* (95 per cent) and add sufficient *water* to produce 100 ml.

Complies with the following test.

**SENSITIVITY** — A mixture of 0.1 ml of the solution and 100 ml of *carbon dioxide-free water* is colourless. Not more than 0.2 ml of 0.02 M *sodium hydroxide* is required to change the colour to pink.

**Phenolphthalein-Thymol Blue Solution:** Dissolve 0.1 g of *thymol blue* in a mixture of 2.2 ml of 0.1 M *sodium hydroxide* and 50 ml of *ethanol* (95 per cent) and dilute to 100 ml with *water*. Mix 3 volumes of this solution with 2 volumes of *phenolphthalein solution*.

**Pyridylazonaphthol;** PAN; 1-(2-Pyridylazo)-2-naphthol;  $C_{15}H_{11}N_3O = 249.27$

General laboratory reagent grade of commerce.

Brick red or orange-red powder; mp, about 140°.

**Pyridylazonaphthol Solution:** A 0.1 per cent w/v solution in *ethanol*.

Complies with the following test.

**SENSITIVITY** — To 50 ml of *water* add 10 ml of *acetate buffer pH 4.4*, 0.1 ml of 0.02 M *disodium edetate* and 0.25 ml of the

reagent under examination; a yellow colour is produced. Add 0.15 ml of a 0.5 per cent w/v solution of *cupric sulphate*; the colour changes to violet.

**Quinaldine Red;** 2-(4-Dimethylaminostyryl) quinoline Ethiodide;  $C_{21}H_{23}IN_2 = 430.33$

When used for the non-aqueous titration in *anhydrous glacial acetic acid*, the colour changes from magenta (basic) to almost colourless (acidic).

**Quinaldine Red Solution:** A 0.1 per cent w/v solution of *quinaldine red* in *methanol*.

**Ruthenium Red;** Ammoniated Ruthenium Oxochloride;  $H_4Cl_6N_{14}O_2Ru_3 \cdot 4H_2O = 858.42$

Microscopical staining grade of commerce.

Brownish red powder.

**Ruthenium Red Solution:** Dissolve 8 mg of *ruthenium red* in 10 ml of *lead acetate solution*.

**Sudan Red G;** CI 12150; Sudan Red I; 1-(2'-Methoxyphenylazo)-2-naphthol;  $C_{17}H_{14}N_4O = 290.32$

Complies with the following test.

**HOMOGENEITY** — Carry out the method for *thin-layer chromatography* (2.4.17), using *silica gel G* as the coating substance and *dichloromethane* as the mobile phase but allowing the solvent front to ascend 10 cm above the line of application. Apply to the plate 10 ml of a 0.1 per cent w/v solution in *dichloromethane*. After removal of the plate, allow it to dry in air. The chromatogram shows only one spot.

**Thymol Blue;** Thymolsulphonphthalein; 4,4'-(3H)-2,1-Benzoxathiol-3-ylidene) dithymol *S,S*-dioxide;  $C_{27}H_{30}O_5S = 466.60$

Brownish green, crystalline powder; soluble in *ethanol* (95 per cent) and in dilute alkali solutions; slightly soluble in *water*.

**Thymol Blue Solution:** Dissolve 0.1 g of *thymol blue* in 2.15 ml of 0.1 M *sodium hydroxide* and 20 ml of *ethanol* (95 per cent). After solution is effected, add sufficient *water* to produce 100 ml.

Complies with the following test.

**SENSITIVITY** — A mixture of 0.1 ml of the solution and 100 ml of *carbon dioxide-free water* to which 0.2 ml of 0.02 M *sodium hydroxide* has been added is blue. Not more than 0.1 ml of 0.02 M *hydrochloric acid* is required to change the colour to yellow.

**Thymol Blue Solution, Ethanolic:** Dissolve 0.1 g of *thymol blue* in 100 ml of *ethanol* (95 per cent) and filter, if necessary.

**Thymolphthalein;** 3,3-Bis(4-hydroxy-5-isopropyl-2-methylphenyl)phthalide;  $C_{28}H_{30}O_4 = 430.55$

White to slightly yellow crystalline powder; soluble in *ethanol* (95 per cent) and in solutions of alkali hydroxides; insoluble in *water*.

**Thymolphthalein Solution:** A 0.1 per cent w/v solution of *thymolphthalein* in *ethanol* (95 per cent).

Complies with the following test.

**SENSITIVITY** — A mixture of 0.05 ml and 100 ml of *carbon dioxide-free water* is colourless. Not more than 0.05 ml of 0.1 M *sodium hydroxide* is required to change the colour to blue.

**Titan Yellow;** CI 19540; Thiazol Yellow;

Sodium 2,2-[(diazamino)di-*p*-phenylene] bis(6-methylbenzothiazole-7-sulphonate):  $C_{28}H_{19}N_5Na_2O_6S_4 = 695.71$

Yellowish brown powder.

**Titan Yellow Solution:** A 0.05 per cent w/v solution of *titan yellow*.

Complies with the following test.

**SENSITIVITY** — Add 0.1 ml to a mixture of 10 ml of *water*; 0.2 ml of a 0.0101 per cent w/v solution of *magnesium sulphate* and 1.0 ml of 1 M *sodium hydroxide*; a pink colour is produced.

**Xylene Cyanol FF:** CI 42135

Blue, ethanol-soluble dye used as a screening agent in *methyl orange-xylene cyanol FF solution*.

**Xylenol Orange;** [3*H*-2,1-Benzoxathiol-3-ylidenebis-(6-hydroxy-5-methyl-*m*-phenylene)methylenenitrilo]tetra acetic acid *S,S*-dioxide Tetrasodium Salt:  $C_{31}H_{28}N_2Na_4O_{13}S = 760.60$

General laboratory reagent grade of commerce.

Reddish brown, crystalline powder; gives a violet colour with mercury, lead, zinc and certain other metal ions, in alkaline solutions. When metal ions are absent, for example in the presence of an excess of disodium edetate, the solution is yellow.

**Xylenol Orange Mixture;** Xylenol Orange Triturate: Triturate 1 part of *xylenol orange* with 99 parts of *potassium nitrate*.

Complies with the following test.

**SENSITIVITY** — Add 50 mg to a mixture of 50 ml of *water*; 1 ml of 2 M *acetic acid* and 0.05 ml of *lead nitrate solution*. Add sufficient *hexamine* to change the colour from yellow to violet red. Add 0.1 ml of 0.1 M *disodium edetate*; the colour changes to yellow.

**Xylenol Orange Solution:** Mix 0.1 g of *xylenol orange* with 100 ml of *water* and filter, if necessary.

## B. Indicator and Test Papers

Indicator and test papers are strips of filter paper of suitable dimension and grade impregnated with an indicator or a

reagent that is sufficiently stable to provide a convenient form of the impregnated substance. Commercial samples of indicator and test papers are available and may be used. Those required in the assays and tests of the Pharmacopoeia may be prepared as described in the following paragraphs.

Treat strong, white filter paper with *hydrochloric acid* and wash with *water* until the last washing does not show an acidic reaction to *methyl red*. Then treat with *dilute ammonia solution* and wash again with *water* until the last washing is not alkaline to *phenolphthalein*. Dry the paper thoroughly and saturate it with the proper strength of the indicator solution or reagent solution and dry carefully in still air by suspending it from glass rods in a space free from acid and other fumes. Cut the paper into strips of suitable size and store in well-closed, light-resistant containers, protected from moisture.

**Lead Acetate Paper:** Prepare from *lead acetate solution* and dry the impregnated paper at 100°, avoiding contact with metal.

**Litmus Paper:** Use *red litmus paper* or *blue litmus paper*, as appropriate.

**Litmus Paper, Blue:** Boil 10 parts of coarsely powdered *litmus* under a reflux condenser for 1 hour with 100 parts of *ethanol* (95 per cent), decant the *ethanol* and discard. To the residue add a mixture of 45 parts of *ethanol* (95 per cent) and 55 parts of *water*. After 2 days, decant the clear liquid. Impregnate strips of filter paper with the extract and allow to dry.

Complies with the following test.

**SENSITIVITY** — Immerse a strip, 60 mm x 10 mm, in 100 ml of 0.002 M *hydrochloric acid*. On shaking, the paper turns red within 45 seconds.

**Litmus Paper, Red:** To the extract obtained in the preparation of *blue litmus paper* add 2 M *hydrochloric acid* dropwise until the blue solution turns red. Impregnate strips of filter paper with the solution and allow to dry.

Complies with the following test.

**SENSITIVITY** — Immerse a strip, 60 mm x 10 mm in 100 ml of 0.002 M *sodium hydroxide*. On shaking, the paper turns blue within 45 seconds.

**Mercuric Chloride Paper:** Smooth white filter paper, not less than 25 mm in width, soaked in a saturated solution of *mercuric chloride*, pressed to remove superfluous solution and dried at about 60° in the dark. The grade of filter paper is such that the weight is between 65 and 120 g per sq.m; the thickness in mm of 400 papers is approximately equal, numerically, to the weight in g per sq.m.

Store in a stoppered bottle in the dark. The paper which has been exposed to sunlight or to the vapour of ammonia affords a lighter stain or no stain at all when employed in the *limit test for arsenic* (2.3.10).



**Starch Iodate Paper;** Starch-iodate Paper: Immerse strips of filter paper in 100 ml of *iodide-free starch solution* containing 0.1 g of *potassium iodate*. Drain and allow to dry protected from light.

**Starch Iodide Paper;** Starch-iodide Paper: Prepare from a mixture of equal volumes of *starch solution* and 5 per cent w/v solution of *potassium iodide* in *water* and dry the impregnated paper protected from light.

Complies with the following test.

**SENSITIVITY** — Mix 0.05 ml of 0.1 M *sodium nitrite* with 4 ml of *hydrochloric acid* and dilute with *water* to 100 ml. Deposit one drop of the resulting solution on the paper; a blue spot appears.

**Titan Yellow Paper:** Impregnate filter paper with *titan yellow solution* and dry at room temperature.

#### 4.4 Standard Solutions

**Acetaldehyde Standard Solution (100 ppm C<sub>2</sub>H<sub>4</sub>O):** Dissolve 1.0 g of *acetaldehyde* in sufficient *2-propanol* to produce 100 ml and dilute 5.0 ml of the solution to 500.0 ml with *2-propanol*.

**Aluminium Standard Solution (2 ppm Al):** Dilute 2 volumes of ass 0.176 per cent w/v solution of *aluminium potassium sulphate* in 0.1 M *sulphuric acid* to 100 volumes with *water*.

**Aluminium Standard Solution (10 ppm Al):** Dilute 1 volume of a 1.39 per cent w/v solution of *aluminium nitrate* to 100 volumes with *water*.

**Ammonium Standard Solution (1 ppm NH<sub>4</sub>):** Dilute 10.0 ml of a 0.0741% w/v solution of *ammonium chloride* to 25.0 ml with *ammonia-free water*. Dilute 1 volume of the resulting solution to 100 volumes with *ammonia-free water* immediately before use.

**Arsenic Standard Solution (1 ppm As):** Dilute 1 volume of *arsenic standard solution (10 ppm As)* to 10 volumes with *water*.

**Arsenic Standard Solution (10 ppm As):** Dissolve 0.330 g of *arsenic trioxide* in 5 ml of 2M *sodium hydroxide* and dilute to 250.0 ml with *water*. Dilute 1 volume of this solution to 100 volumes with *water*.

**Barium Standard Solution (10 ppm Ba):** Dilute 1.0 ml of a 0.178 per cent w/v solution of *barium chloride* to 100.0 ml with *water*.

**Cadmium Standard Solution (10 ppm Cd):** Dilute 2.0 ml of a 0.228 per cent w/v solution of *cadmium sulphate* to 200.0 ml with *water*.

**Calcium Standard Solution (10 ppm Ca):** Dissolve 0.624 g of dried *calcium carbonate* in *distilled water* containing 3 ml of 5 M *acetic acid* and dilute to 250.0 ml with *distilled water*.

Dilute 1 volume of this solution to 100 volumes with *distilled water*.

**Calcium Standard Solution (100 ppm Ca), Ethanolic:** Dissolve 2.50 g of dried *calcium carbonate* in 12 ml of 5 M *acetic acid* and dilute to 1000.0 ml with *distilled water*. Dilute 1 volume of this solution to 10 volumes with *ethanol* (95 per cent).

**Chloride Standard Solution (5 ppm Cl):** Dilute 1 volume of a 0.0824 per cent w/v solution of *sodium chloride* to 100 volumes with *water*.

**Chloride Standard Solution (25 ppm Cl):** Dilute 5 volumes of a 0.0824 per cent w/v solution of *sodium chloride* to 100 volumes with *water*.

**Copper Standard Solution:** Dissolve 1.965 g of *cupric sulphate*, accurately weighed, in sufficient 0.1 M *hydrochloric acid* to produce 1000.0 ml. Transfer 3.0 ml to a 1000-ml volumetric flask and dilute to volume with 0.1 M *hydrochloric acid*.

**Copper Standard Solution (10 ppm Cu):** Dilute 1 volume of a 0.393 per cent w/v solution of *cupric sulphate* to 100 volumes with *water*.

**Digitoxin Standard Solution;** Digitoxin Reagent: Dissolve 0.125 g of digitoxin RS in sufficient *glacial acetic acid* to produce 100.0 ml. Dilute 4.0 ml of this solution to 100.0 ml with *glacial acetic acid*. To 25.0 ml of the resulting solution add 3.0 ml of *water* and mix well.

**Digoxin Standard Solution:** Dissolve 0.125 g of *digoxin RS* in sufficient *glacial acetic acid* to produce 100.0 ml. Dilute 4.0 ml of this solution to 100.0 ml with *glacial acetic acid*. To 25.0 ml of the resulting solution add 3.0 ml of *water* and mix well.

**Formaldehyde Standard Solution (5 ppm CH<sub>2</sub>O):** Dilute 1 volume of a solution containing 3.0 g of *formaldehyde solution* in 1000.0 ml to 200 volumes with *water*.

**Iron Standard Solution (2 ppm Fe):** Dilute 1 volume of *iron standard solution (20 ppm Fe)* to 10 volumes with *water*.

**Iron Standard Solution (8 ppm Fe):** Dilute 4 volumes of *iron standard solution (20 ppm Fe)* to 100 volumes with *water*.

**Iron Standard Solution (10 ppm Fe):** Dissolve 7.022 g of *ferrous ammonium sulphate* in *water* containing 25 ml of 1 M *sulphuric acid* and add sufficient *water* to produce 1000.0 ml. Dilute 1 volume to 100 volumes with *water*. Contains iron in ferrous state.

**Iron Standard Solution (20 ppm Fe):** Dilute 1 volume of a 0.1726 per cent w/v solution of *ferric ammonium sulphate* in 0.05 M *sulphuric acid* to 10 volumes with *water*. Contains iron in ferric state.

**Lead Standard Solution:** On the day of use, dilute 10 ml of *lead nitrate stock solution* with *water* to 100 ml. 1 ml of *lead standard solution* contains the equivalent of 10 µg of lead. A control comparison solution prepared with 2.0 ml of *lead*

*standard solution* contains, when compared to a solution representing 1.0 g of the substance under examination, the equivalent of 20 ppm of lead.

**Lead Standard Solution (1 ppm Pb):** Dilute 1 volume of *lead standard solution (10 ppm Pb)* to 10 volumes with *water*.

**Lead Standard Solution (2 ppm Pb):** Dilute 1 volume of *lead standard solution (10 ppm Pb)* to 5 volumes with *water*.

**Lead Standard Solution (10 ppm Pb):** Dilute 1 volume of *lead standard solution (100 ppm Pb)* to 10 volumes with *water*.

**Lead Standard Solution (20 ppm Pb):** Dilute 1 volume of *lead standard solution (100 ppm Pb)* to 5 volumes with *water*.

**Lead Standard Solution (100 ppm Pb):** Dilute 1 volume of *lead standard solution (0.1 per cent Pb)* to 10 volumes with *water*.

**Lead Standard Solution (0.1 per cent Pb):** Dissolve 0.400 g of *lead nitrate* in *water* containing 2 ml of *nitric acid* and add sufficient *water* to produce 250.0 ml.

**Nickel Standard Solution (10 ppm Ni):** Dilute 1 volume of a 0.478 per cent w/v solution of *nickel sulphate* to 100 volumes with *water*.

**Nitrate Standard Solution (2 ppm NO<sub>3</sub>):** Dilute 1 volume of *nitrate standard solution (100 ppm NO<sub>3</sub>)* to 50 volumes with *water*.

**Nitrate Standard Solution (100 ppm NO<sub>3</sub>):** Dilute 1 volume of a 0.163 per cent w/v solution of *potassium nitrate* to 10 volumes with *water*.

**Phosphate Standard Solution (5 ppm PO<sub>4</sub>):** Dilute 1 volume of a 0.143 per cent w/v solution of *potassium dihydrogen phosphate* to 200 volumes with *water*.

**Silver Standard Solution (5 ppm Ag):** Dilute 1 volume of a 0.079 per cent w/v solution of silver nitrate to 100 volumes with *water*.

**Sulphate Standard Solution (10 ppm SO<sub>4</sub>):** Dilute 1 volume of a 0.181 per cent w/v solution of *potassium sulphate* in *distilled water* to 100 volumes with the same solvent.

**Sulphate Standard Solution (10 ppm SO<sub>4</sub>), Ethanolic:** Dilute 1 volume of a 0.181 per cent w/v solution of *potassium sulphate* in *ethanol (30 per cent)* to 100 volumes with *ethanol (30 per cent)*.

**Tin Standard Solution (5 ppm Sn):** Dissolve 0.500 g of *tin* in a mixture of 5 ml of *water* and 25 ml of *hydrochloric acid* and add sufficient *water* to produce 1000.0 ml. Dilute 1 volume of this solution to 100 volumes with a 2.5 per cent v/v solution of *hydrochloric acid*.

**Zinc Standard Solution (10 ppm Zn):** Dilute 1 volume of *zinc standard solution (100 ppm Zn)* to 10 volumes with *water*.

**Zinc Standard Solution (25 ppm Zn):** Dilute 25 volumes of *zinc standard solution (100 ppm Zn)* to 100 volumes with *water*.

**Zinc Standard Solution (100 ppm Zn):** Dissolve 0.440 g of *zinc sulphate* in *water* containing 1 ml of 5M *acetic acid* and add sufficient *water* to produce 100.0 ml.

Dilute 1 volume of this solution to 10 volumes with *water* immediately before use.

## 4.5 Volumetric Reagents and Solutions

Volumetric solutions, also known as standard solutions, are solutions of reagents of known concentrations intended primarily for use in quantitative determinations. Concentrations are usually expressed in terms of *molarity (M)*.

### Molar Solutions

A molar solution contains 1g molecule of the reagent in 1000 ml of the solution. Thus, each litre of a molar solution of *sodium nitrite* contains 69.0 g of NaNO<sub>2</sub> and each litre of a molar solution of *disodium edetate* contains 372.2 g of C<sub>10</sub>H<sub>14</sub>N<sub>2</sub>Na<sub>2</sub>O<sub>8</sub>·2H<sub>2</sub>O. Solutions containing one-tenth of a gram-molecule of the reagent in 1000 ml are designated as 'tenth-molar' or 0.1M; other molarities are similarly indicated.

### Preparation and Standardisation of Volumetric Solutions

It is not always possible nor is it essential, to prepare volumetric solutions of a desired theoretical molarity. A solution of approximately the desired molarity is prepared and standardised by titration against a solution of a primary standard. The molarity factor so obtained is used in all calculations, where such standardised solutions are employed. As the strength of a standard solution may change upon standing, the molarity factor should be redetermined frequently. Volumetric solutions should not differ from the prescribed strength by more than 10 per cent and the molarity should be determined with a precision of 0.2 per cent.

When solutions of a reagent are used in several molarities, the details of the preparation and standardisation are usually given for the most commonly used strength. Stronger or weaker solutions are prepared and standardised using proportionate amounts of the reagent or by making an exact dilution of a stronger solution. Volumetric solutions prepared by dilution should be restandardised either as directed for the stronger solution or by comparison with another volumetric solution having a known ratio to the stronger solution.

The water used in preparing volumetric solutions complies with the requirements of the monograph on Purified Water, unless otherwise specified. When used for the preparation of

unstable solutions such as potassium permanganate or sodium thiosulphate, it should be freshly boiled and cooled. When a solution is to be used in an assay in which the end-point is determined by an electrochemical process (e.g. potentiometrically), the solution must be standardised in the same way.

#### Blank Determinations

Where it is directed that "any necessary correction" be made by a blank determination, the determination should be done using the same quantities of the same reagents treated in the same manner as the solution or mixture containing the portion of the substance under examination but omitting the substance under examination.

#### Primary Standards

These are materials which, after drying under the specified conditions, are recommended for use as primary standards in the standardisation of volumetric solutions. The following are recommended for use as primary standards.

**Arsenic Trioxide:** Sublime *arsenic trioxide* in an appropriate apparatus and store over *silica gel*.

**Benzoic Acid:** Sublime *benzoic Acid* in an appropriate apparatus and store in a tightly- closed container.

**Potassium Bromate:** Recrystallise *potassium bromate* from boiling *water*. Collect the crystals and dry to constant weight at 180°. Store in a tightly-closed container.

**Potassium Dichromate:** Heat *potassium dichromate* to 140° to 150° in an oven, cool in a desiccator and powder in a glass mortar.

**Potassium Hydrogen Phthalate:** Recrystallise *potassium hydrogen phthalate* from boiling *water*, collect the crystals at a temperature above 35° and dry to constant weight at 110°. Store in a tightly-closed container.

**Potassium Iodate:** Recrystallise *potassium iodate* from boiling *water*. Collect the crystals and dry to constant weight at 120°. Store in tightly-closed container.

**Sodium Carbonate, Anhydrous:** Filter at room temperature a saturated solution of *sodium carbonate*. Introduce slowly into the filtrate a stream of *carbon dioxide*, with constant cooling and stirring. After about 2 hours, collect the precipitate on a sintered glass filter. Wash the filter with ice-cold *water* saturated with *carbon dioxide*. After drying at 100° to 105°, heat to constant weight at 270° to 300°, stirring from time to time. Store in a tightly-closed container.

**Sodium Chloride:** To 1 volume of a saturated solution of *sodium chloride* add 2 volumes of *hydrochloric acid*. Collect the crystals formed and wash with *hydrochloric acid*. Remove the hydrochloric acid by heating on a *water-bath* and dry the

crystals to constant weight at 300°. Store protected from moisture.

**Sulphanilic Acid:** Recrystallise *sulphanilic acid* from boiling *water*. Filter and dry to constant weight at 100° to 105°.

**Zinc, Granulated:** Wash *granulated zinc* with *dilute hydrochloric acid*, followed by *water*, *ethanol (95 per cent)* and finally *acetone*. Dry at 100° for 5 minutes and cool in a desiccator over *silica gel*.

#### Volumetric Solutions

**Ammonium Thiocyanate, 0.1 M:** Dissolve 7.612 g of *ammonium thiocyanate* in sufficient *water* to produce 1000 ml. Standardise the solution in the following manner.

Pipette 30.0 ml of 0.1 M *silver nitrate* into a glass-stoppered flask, dilute with 50 ml of *water*, add 2 ml of *nitric acid* and 2 ml of *ferric ammonium sulphate solution* and titrate with the *ammonium thiocyanate solution* to the first appearance of a red-brown colour.

1 ml of 0.1 M *silver nitrate* is equivalent 0.007612 g of  $\text{NH}_4\text{SCN}$ .

**Barium Chloride, 0.05 M:** Dissolve 12.2 g of *barium chloride* in sufficient *water* to produce 1000 ml. Standardise the solution in the following manner.

To 10.0 ml of the solution add 60 ml of *water*, 3 ml of *strong ammonia solution* and 0.5 to 1 mg of *metalphthalein* as indicator and titrate with 0.05 M *disodium edetate*. As the solution begins to decolorise, add 50 ml of *ethanol (95 per cent)* and titrate until the bluish violet colour is discharged.

1 ml of 0.05 M *disodium edetate* is equivalent to 0.012215 g of  $\text{BaCl}_2 \cdot 2\text{H}_2\text{O}$ .

**Benzethonium Chloride, 0.004 M:** Dissolve 1.792 g of *benzethonium chloride*, previously dried to constant weight at 105°, in sufficient *water* to produce 1000 ml. Standardise the solution from the content of  $\text{C}_{27}\text{H}_{42}\text{ClNO}_2$  in the dried benzethonium chloride determined in the following manner.

Dissolve 0.35 g of the dried substance in 30 ml of *anhydrous Glacial acetic acid*, add 6 ml of *mercuric acetate solution*. Titrate with 0.05 ml of *crystal violet solution* as indicator. Perform a blank determination and make any necessary correction.

1 ml of 0.1 M *perchloric acid* is equivalent to 0.04481 g of  $\text{C}_{27}\text{H}_{42}\text{ClNO}_2$ .

**Bromine, 0.05 M:** Dissolve 3 g of *potassium bromate* and 15 g of *potassium bromide* in sufficient *water* to produce 1000 ml. Standardise the solution in the following manner.

Pipette 25.0 ml of the solution into a 500 - ml iodine flask and dilute with 120 ml of *water*. Add 5 ml of *hydrochloric acid*, insert the stopper in the flask and shake it gently. Add 5 ml of *potassium iodide solution*, again insert the stopper and allow



it to stand for 5 minutes in the dark. Titrate the liberated iodine with 0.1 M sodium thiosulphate using 3 ml of starch solution, added towards the end of the titration, as indicator.

1 ml of 0.1 M sodium thiosulphate is equivalent to 0.01598 g of Br<sub>2</sub>.

Store in dark amber-coloured, glass stoppered bottles.

**Ceric Ammonium Nitrate, 0.1 M;** Ammonium Ceric Nitrate, 0.1M: Shake a solution containing 56 ml of sulphuric acid and 54.82 g of ceric ammonium nitrate for 2 minutes and carefully add five successive quantities, each of 100 ml, of water, shaking after each addition. Dilute the clear solution to 1000 ml with water. After 10 days, standardise the solution as described under 0.1 M ceric ammonium sulphate.

1 ml of 0.1 M ceric ammonium nitrate is equivalent to 0.004946 g of As<sub>2</sub>O<sub>3</sub>.

Store protected from light.

**Ceric Ammonium Sulphate, 0.1 M;** Ammonium Ceric Sulphate, 0.1M: Dissolve 65 g of ceric ammonium sulphate, with the aid of gentle heat, in a mixture of 30 ml of sulphuric acid and 500 ml of water. Cool, filter the solution, if turbid, and dilute to 1000 ml with water. Standardise the solution in the following manner.

Weigh accurately about 0.2 g of arsenic trioxide, previously dried at 105 ° for 1 hour, and transferred to a 500-ml conical flask. Wash down the inner walls of the flask with 25 ml of a 8.0 per cent w/v solution of sodium hydroxide, swirl to dissolve, add 100 ml of water and mix. Add 30 ml of dilute sulphuric acid, 0.15 ml of osmic acid solution, 0.1 ml of ferroin sulphate solution and slowly titrate with the ceric ammonium sulphate solution until the pink colour is changed to a very pale blue, adding the titrant slowly towards the end-point.

1 ml of 0.1 M ceric ammonium sulphate is equivalent to 0.004946 g of As<sub>2</sub>O<sub>3</sub>.

**Cupric Sulphate, 0.02 M:** Dissolve 5.0 g of cupric sulphate in water and dilute to 1000 ml with water. Standardise the solution in the following manner.

To 20.0 ml add 2 g of sodium acetate and titrate with 0.02 M disodium edetate, using 0.1 ml of pyridylazonaphthol solution as indicator, until the colour changes from violet-blue to bright green, adding the titrant slowly towards the end-point.

1 ml of 0.02 M disodium edetate is equivalent to 0.004994 g of CuSO<sub>4</sub>·5H<sub>2</sub>O.

**Diocetyl Sodium Sulphosuccinate, 0.0005 M:** Dissolve 0.225 g of diocetyl sodium sulphosuccinate in warm water, cool and dilute to 1000 ml with water. Standardise the solution in the following manner.

To 25.0 ml add 25.0 ml of a solution containing 20 per cent w/v of anhydrous sodium sulphate and 2 per cent w/v sodium

carbonate, 50 ml of chloroform and 1.5 ml of bromophenol blue solution and mix. Titrate with 0.01 M tetrabutylammonium iodide until about 1 ml remains to be added for the end-point. Stopper the flask, shake vigorously for 2 minutes and continue the titration, in increments of 0.5 ml, shaking vigorously and allowing the flask to stand for about 10 seconds after each addition. Continue the titration until a blue colour just appears in the chloroform layer.

1 ml of 0.01 M tetrabutylammonium iodide is equivalent to 0.004446 g of C<sub>20</sub>H<sub>37</sub>NaO<sub>7</sub>S.

**Disodium Edetate, 0.1 M:** Dissolve 37.2 g of disodium edetate in sufficient water to produce 1000 ml. Standardise the solution in the following manner.

Weigh accurately about 0.8 g of granulated zinc, dissolve by gentle warming in 12 ml of dilute hydrochloric acid and 0.1 ml of bromine water. Boil to remove excess bromine, cool and add sufficient water to produce 200.0 ml. Pipette 20.0 ml of the resulting solution into a flask and nearly neutralise with 2 M sodium hydroxide. Dilute to about 150 ml with water, add sufficient ammonia buffer pH 10.0 to dissolve the precipitate and add 5 ml in excess. Add 50 mg of mordant black II mixture and titrate with the disodium edetate solution until the solution turns green.

1 ml of 0.1 M disodium edetate is equivalent to 0.000654 g of Zn.

**Ferric Ammonium Sulphate, 0.1 M:** Ammonium Iron(III) Sulphate, 0.1M: Dissolve 50 g of ferric ammonium sulphate in a mixture of 300 ml of water and 6 ml of sulphuric acid and dilute with sufficient freshly boiled and cooled water to produce 1000 ml. Standardise the solution in the following manner.

To 25.0 ml add 3 ml of hydrochloric acid and 2 g of potassium iodide, allow to stand for 10 minutes and titrate the liberated iodine with 0.1 M sodium thiosulphate using starch solution, added towards the end of the titration, as indicator.

1 ml of 0.1 M sodium thiosulphate is equivalent to 0.004822 g of FeNH<sub>4</sub>(SO<sub>4</sub>)<sub>2</sub>·12H<sub>2</sub>O.

**Ferrous Ammonium Sulphate, 0.1 M;** Ammonium Iron(II) Sulphate, 0.1M; Dissolve 40 g of ferrous ammonium sulphate in a previously cooled mixture of 40 ml of sulphuric acid and 200 ml of water, dilute with sufficient freshly boiled and cooled water to produce 1000 ml. Standardise the solution in the following manner.

Measure accurately 25.0 ml of the solution into a flask, add 2 drops of 1,10-phenanthroline solution and titrate with 0.1 M ceric ammonium sulphate until the red colour is changed to pale blue.

1 ml of 0.1 M ceric ammonium sulphate is equivalent to 0.03921 g of Fe(NH<sub>4</sub>)<sub>2</sub>(SO<sub>4</sub>)<sub>2</sub>·6H<sub>2</sub>O.



**Hydrochloric Acid, 1 M:** Dilute 85 ml of *hydrochloric acid* with *water* to produce 1000 ml. Standardise the solution in the following manner.

Weigh accurately about 1.5 g of *anhydrous sodium carbonate*, previously heated at about 270° for 1 hour. Dissolve it in 100 ml of *water* and add 0.1 ml of *methyl red solution*. Add the acid slowly from a burette, with constant stirring, until the solution becomes faintly pink. Heat the solution to boiling, cool and continue the titration. Heat again to boiling and titrate further as necessary until the faint pink colour is no longer affected by continued boiling.

1 ml of 1 M *hydrochloric acid* is equivalent to 0.05299 g of  $\text{Na}_2\text{CO}_3$ .

**Hydrochloric Acid, 0.5 M Methanolic:** Take 40 ml of *water* in a 1000-ml volumetric flask and slowly add 43 ml of *hydrochloric acid*. Cool and add *methanol* to volume. Standardise the solution in the following manner.

Weigh accurately about 800 mg of *anhydrous sodium carbonate*, previously heated at about 270° for 1 hour, and proceed as directed under 1 M *hydrochloric acid*.

**Iodine, 0.05 M:** Dissolve about 14 g of *iodine* in a solution of 36 g of *potassium iodide* in 100 ml of *water*, add three drops of *hydrochloric acid* and dilute with *water* to 1000 ml. Standardise the solution in the following manner.

Weigh accurately about 0.15 g of *arsenic trioxide*, previously dried at 105° for 1 hour, and dissolve in 20 ml of 1 M *sodium hydroxide* by warming, if necessary. Dilute with 40 ml of *water*, add 0.1 ml of *methyl orange solution* and add dropwise *dilute hydrochloric acid* until the yellow colour is changed to pink. Add 2 g of *sodium carbonate*, dilute with 50 ml of *water* and add 3 ml of *starch solution*. Titrate with the iodine solution until a permanent blue colour is produced.

1 ml of 0.05 M *iodine* is equivalent to 0.004946 g of  $\text{As}_2\text{O}_3$ .

Store in amber-coloured, glass stoppered bottles.

**Lead Nitrate, 0.1 M:** Dissolve 33.12 g of *lead nitrate* in sufficient *water* to produce 1000 ml. Standardise the solution in the following manner.

Pipette 50.0 ml of the solution into a flask, add 50 mg of *xyleneol orange mixture* and sufficient *hexamine* to produce a violet-pink colour and titrate with 0.1 M *disodium edetate* to a lemon-yellow end point.

1 ml of 0.1 M *disodium edetate* is equivalent to 0.03312 g of  $\text{Pb}(\text{NO}_3)_2$ .

**Lithium Methoxide, 0.1 M:** Dissolve in small portions 0.7 g of freshly cut *lithium* in 150 ml of *anhydrous methanol*, cooling the flask during the addition of the metal. When reaction is complete add sufficient *toluene* to produce 1000 ml. If cloudiness or precipitation occurs, add sufficient *anhydrous*

*methanol* to clarify the solution. Standardise the solution immediately before use in the following manner.

Weigh accurately about 0.25 g of *benzoic acid*, dissolve in 25 ml of *dimethylformamide*. Titrate with lithium methoxide solution, using *quinaldine red solution* as the indicator and protecting the solution from atmospheric carbon dioxide throughout the titration. Perform a blank determination and make any necessary correction.

1 ml of 0.1 M *lithium methoxide* is equivalent to 0.01221 g of  $\text{C}_7\text{H}_6\text{O}_2$ .

Store the solution in a manner suitably protected from carbon dioxide and moisture.

**Magnesium Sulphate, 0.05 M:** Dissolve 12.5 g of *magnesium sulphate* in sufficient *water* to produce 1000 ml. Standardise the solution in the following manner.

Pipette 30.0 ml of solution into a flask, add 20 ml of *water*, 10 ml of *strong ammonia-ammonium chloride* solution and 50 mg of *mordant black II* mixture. Titrate with 0.1 M *disodium edetate* until the colour changes from violet to full blue. 1 ml of 0.1 M *disodium edetate* is equivalent to 0.02465 g of  $\text{MgSO}_4 \cdot 7\text{H}_2\text{O}$ .

**Mercuric Nitrate, 0.02 M:** Dissolve 6.85 g of *mercuric nitrate* in 20 ml of 1 M *nitric acid* and add sufficient *water* to produce 1000 ml. Standardise the solution in the following manner.

Dissolve 15 mg of *sodium chloride* in 50 ml of *water* and titrate with the mercuric nitrate solution determining the end-point potentiometrically, using a platinum or mercury indicator electrode and a mercury-mercurous sulphate reference electrode.

1 ml of 0.02 M *mercuric nitrate* is equivalent to 0.002338 g of  $\text{NaCl}$ .

**Nitric Acid, 1 M:** Dilute 63 ml of *nitric acid* with sufficient *water* to produce 1000 ml. Standardise the solution in the following manner.

Dissolve 2 g of *anhydrous sodium carbonate* in 50 ml of *water* and titrate with the nitric acid solution using *methyl orange solution* as indicator until the solution becomes reddish yellow. Boil for 2 minutes, cool and continue the titration until the reddish yellow colour is restored.

1 ml of 1 M *nitric acid* is equivalent to 0.053 g of  $\text{Na}_2\text{CO}_3$ .

**Perchloric Acid, 0.1 M:** Mix 8.5 ml of *perchloric acid* with 500 ml of *anhydrous glacial acetic acid* and 25 ml of *acetic anhydride*, cool and add *anhydrous glacial acetic acid* to produce 1000 ml. Allow the prepared solution to stand for 1 day for the excess *acetic anhydride* to be combined and carry out the determination of water (2.3.43). If the *water* content exceeds 0.05 per cent, add more *acetic anhydride*. If the solution contains no titratable water, add sufficient *water* to

obtain a content of *water* between 0.02 per cent and 0.05 per cent. Allow the solution to stand for 1 day and again titrate the *water* content. The solution so obtained should contain between 0.02 per cent and 0.05 per cent of *water*. Standardise the solution in the following manner.

Weigh accurately about 0.35 g of *potassium hydrogen phthalate*, previously powdered lightly and dried at 120° for 2 hours and dissolve it in 50 ml of *anhydrous glacial acetic acid*. Add 0.1 ml of *crystal violet solution* and titrate with the perchloric acid solution until the violet colour changes to emerald-green. Perform a blank determination and make any necessary correction.

1 ml of 0.1 M perchloric acid is equivalent to 0.02042 g of  $C_8H_5KO_4$ .

Other strengths of perchloric acid should be prepared by diluting 0.1 M perchloric acid appropriately with *anhydrous glacial acetic acid*.

In the tests and assays of the Pharmacopoeia, this solution is specified as “0.1 M perchloric acid”. Thus the solution in *anhydrous glacial acetic acid* is to be used unless the words “in dioxan” are stated.

**Potassium Dichromate, 0.0167 M:** Weigh 4.9 g of *potassium dichromate*, previously powdered and dried in a desiccator for 4 hours, and dissolve in sufficient *water* to produce 1000 ml. Standardise the solution in the following manner.

To 20.0 ml of the solution add 1 g of *potassium iodide* and 7 ml of 2 M *hydrochloric acid*. Add 250 ml of *water* and titrate with 0.1 M *sodium thiosulphate*, using 3 ml of *starch solution*, added towards the end point of the titration, as indicator until the colour changes from blue to light green.

1 ml of 0.1 M *sodium thiosulphate* is equivalent to 0.0049 g of  $K_2Cr_2O_7$ .

**Potassium Hydrogen Phthalate, 0.05 M:** Dissolve 10.21 g of *potassium hydrogen phthalate* in about 800 ml of *anhydrous glacial acetic acid*, heat on a water-bath until completely dissolved, protected from humidity, cool to 20° and add sufficient *anhydrous glacial acetic acid* to produce 1000 ml.

**Potassium Hydroxide, 0.1 M:** Dissolve about 6 g of *potassium hydroxide* in sufficient *carbon dioxide free water* to produce 1000 ml. Standardise the solution in the following manner.

Titrate 20.0 ml of the solution with 0.1 M *hydrochloric acid* using 0.5 ml of *phenolphthalein solution* as indicator.

1 ml of 0.1 M *hydrochloric acid* is equivalent to 0.005611 g of KOH.

**Potassium Hydroxide, 0.1 M Ethanolic:** Dissolve about 6 g of *potassium hydroxide* in 5 ml of *water* and add sufficient *aldehyde-free ethanol (95 per cent)* to produce 1000 ml. Allow the solution to stand in a tightly-stoppered bottle for

24 hours. Then quickly decant the clear supernatant liquid into a suitable, tightly-closed container and standardise the solution in the following manner.

Pipette 20.0 ml of 0.1 M *hydrochloric acid* into a flask, dilute with 50 ml of *water*, add 0.1 ml of *phenolphthalein solution* and titrate with the ethanolic potassium hydroxide solution until a permanent pale pink colour is produced.

1 ml of 0.1 M *hydrochloric acid* is equivalent to 0.00561 g of KOH.

Store protected from light and moisture.

**Potassium Hydroxide in ethanol (60 per cent), 0.5 M:** Dissolve 30 g of *potassium hydroxide* in sufficient *ethanol (60 per cent)* to produce 1000 ml. Standardise the solution in the following manner.

Pipette 20.0 ml of standardise 0.5 M *hydrochloric acid* into a flask, add 0.1 ml of *phenolphthalein solution* and titrate with the ethanolic potassium hydroxide solution until permanent pale-pink colour is produced.

1 ml of 0.5 M *hydrochloric acid* is equivalent to 0.02806 g of KOH.

**Potassium Iodate, 0.05 M:** Weigh accurately 10.7 g of *potassium iodate*, previously dried at 110° to constant weight, in sufficient *water* to produce 1000 ml. Standardise the solution in the following manner.

Dilute 25.0 ml of the solution to 100 ml with *water* and to 20.0 ml of this solution add 2 g of *potassium iodide* and 10 ml of 1 M *sulphuric acid*. Titrate with 0.1 M *sodium thiosulphate* using 1 ml of *starch solution*, added towards the end of the titration, as indicator.

1 ml of 0.1 M *sodium thiosulphate* is equivalent to 0.003566 g of  $KIO_3$ .

**Potassium Permanganate, 0.02 M:** Dissolve 3.2 g of *potassium permanganate* in 1000 ml of *water*, heat on a water-bath for 1 hour, allow to stand for 2 days and filter through glass wool. Standardise the solution in the following manner.

To 25.0 ml of the solution in a glass-stoppered flask add 2 g of *potassium iodide*, followed by 10 ml of 1 M *sulphuric acid*. Titrate the liberated iodine with 0.1 M *sodium thiosulphate*, using 3 ml of *starch solution*, added towards the end of the titration, as indicator. Perform a blank determination and make necessary correction.

1 ml of 0.1 M *sodium thiosulphate* is equivalent to 0.003161 g of  $KMnO_4$ .

Store protected from light.

**Silver Nitrate, 0.1 M:** Dissolve 17.0 g in sufficient *water* to produce 1000 ml. Standardise the solution in the following manner.

Weigh accurately about 0.1 g of *sodium chloride*, previously dried at 110° for 2 hours and dissolve in 5 ml of *water*. Add 5 ml of *acetic acid*, 50 ml of *methanol* and 0.15 ml of *eosin solution*. Stir, preferably with magnetic stirrer, and titrate with the silver nitrate solution.

1 ml of 0.1 M *silver nitrate* is equivalent to 0.005844 g of NaCl.

Store protected from light.

**Sodium Dodecyl Sulphate, 0.001 M:** Dissolve 0.2884 g of *sodium dodecyl sulphate*, calculated with reference to the substance dried at 105° for 2 hours, in sufficient *water* to produce 1000 ml. Standardise the solution in the following manner.

To 50.0 ml add 15 ml of *chloroform*, 10 ml of 1 M *sulphuric acid* and 1 ml of *dimethyl yellow-oracet blue solution* and titrate with 0.004M *benzethonium chloride*, shaking vigorously and allowing the layers to separate after each addition, until the chloroform layer acquires a permanent clear green colour.

1 ml of 0.004 M *benzethonium chloride* is equivalent to 0.001154 g of  $C_{12}H_{25}NaO_4S$ .

**Sodium Hydroxide, 1 M:** Dissolve 42 g of *sodium hydroxide* in sufficient *carbon dioxide-free water* to produce 1000 ml. Standardise the solution in the following manner.

Weigh accurately about 5 g of *potassium hydrogen phthalate*, previously powdered and dried at 120° for 2 hours, and dissolve in 75 ml of *carbon dioxide-free water*. Add 0.1 ml of *phenolphthalein solution* and titrate with the sodium hydroxide solution until a permanent pink colour is produced. 1 ml of 1 M *sodium hydroxide* is equivalent to 0.2042 g of  $C_8H_5KO_4$ .

Store in bottles with well-fitted suitable stoppers which prevent access to atmospheric carbon dioxide.

Volumetric solutions of *sodium hydroxide* must be restandardise frequently. Solutions of lower concentrations are prepared by quantitatively diluting accurately measured volumes of 0.1 M *sodium hydroxide* with sufficient *carbon dioxide-free water* to give the desired concentration.

**Sodium Hydroxide, 0.1 M Ethanolic:** Dissolve 4.2 g of *sodium hydroxide* in 5 ml of *water* and add sufficient *aldehyde-free ethanol* to produce 1000 ml. Allow the solution to stand in a tightly-stoppered bottle for 24 hours. Then quickly decant the clear supernatant liquid into a suitable, tightly-closed container. Standardise the solution in the following manner.

Weigh accurately about 0.6 g of *benzoic acid*, dissolve in a mixture of 30 ml of *ethanol (95 per cent)* and 6 ml of *water* and titrate with the ethanolic sodium hydroxide solution, using 0.2 ml of *thymolphthalein solution* as indicator. 1 ml of 0.1 M *ethanolic sodium hydroxide* is equivalent to 0.01221 g of  $C_7H_6O_2$ .

Store protected from light and moisture.

**Sodium Methoxide, 0.1 M:** Cool 150 ml of *anhydrous methanol* in ice *water* and add, in small portions, about 2.5 g of freshly cut *sodium*. When the metal has dissolved, add sufficient *toluene*, previously dried over sodium wire, to produce 1000 ml. Standardise the solution in the following manner immediately before use.

Weigh accurately about 0.4 g of *benzoic acid*, dissolve in 80 ml of *dimethylformamide*, add 0.15 ml of *thymolphthalein solution* and titrate with sodium methoxide solution to a blue end-point. Protect the solution from atmospheric carbon dioxide throughout the titration. Perform a blank determination and make any necessary correction.

1 ml of 0.1 M *sodium methoxide* is equivalent to 0.01221 g of  $C_7H_6O_2$ .

Store protected from carbon dioxide and moisture.

**Sodium Nitrite, 0.1 M:** Dissolve 7.5 g of *sodium nitrite* in sufficient *water* to produce 1000 ml. Standardise the solution in the following manner.

Dissolve 0.3 g of *sulphanilic acid* in 50 ml of 2 M *hydrochloric acid*, add 3 g of *potassium bromide*, cool in ice and titrate with the sodium nitrite solution determining the end-point potentiometrically.

1 ml of 0.1 M *sodium nitrite* is equivalent to 0.01732 g of  $C_6H_7NO_3S$ .

**Sodium Thiosulphate, 0.1 M:** Dissolve 25 g of *sodium thiosulphate* and 0.2 g of *sodium carbonate* in *carbon dioxide-free water* and dilute to 1000 ml with the same solvent. Standardise the solution in the following manner.

Dissolve 0.200 g of *potassium bromate*, weighed accurately, in sufficient *water* to produce 250.0 ml. To 50.0 ml of this solution add 2 g of *potassium iodide* and 3 ml of 2 M *hydrochloric acid* and titrate with the sodium thiosulphate solution using *starch solution*, added towards the end of the titration, as indicator until the blue colour is discharged.

1 ml of 0.1 M *sodium thiosulphate* is equivalent to 0.002784 g of  $KBrO_3$ .

Restandardise the solution frequently.

**Sulphuric Acid, 0.5 M:** Add slowly, with stirring, 30 ml of *sulphuric acid* to about 1000 ml of *water*, allow to cool 25° and standardise against *anhydrous sodium carbonate* as described under 1 M *hydrochloric acid*.

1 ml of 0.5 M *sulphuric acid* is equivalent to 0.05299 g of  $Na_2CO_3$ .

**Sulphuric Acid, 0.25 M Ethanolic:** Add slowly, with stirring, 13.9 ml of *sulphuric acid* to a sufficient quantity of *ethanol* to produce 1000 ml. Cool and standardise against *anhydrous*

*sodium carbonate* as described under *0.5 M methanolic hydrochloric acid*.

**Tetrabutylammonium Hydroxide, 0.1 M:** Dissolve 40 g of *tetrabutylammonium iodide* in 90 ml of *dehydrated methanol* in a glass-stoppered flask. Place in an ice-bath, add 20 g of powdered *silver oxide*, insert the stopper and agitate vigorously for 1 hour. Centrifuge a few ml, and test the supernatant liquid for iodides (2.3.1). If the test is positive, add an additional 2 g of *silver oxide* and continue to stand for 30 minutes with intermittent agitation. When all of the iodide has reacted, filter through fine sintered-glass filter. Rinse the flask and filter with three quantities, each of 50 ml, of *anhydrous toluene*. Add the washings of the filtrate and dilute to 1000 ml with *anhydrous toluene*. Flush the solution for 10 minutes with dry, carbon dioxide-free nitrogen. Store protected from carbon dioxide and moisture, and discard after 60 days.

Alternatively, prepare the solution by diluting a suitable volume of commercially available tetrabutylammonium hydroxide solution in *methanol* with a mixture of four volumes of *anhydrous toluene* and 1 volume of *dehydrated methanol*.

Standardise the solution in the following manner immediately before use.

Weigh accurately about 0.4 g of *benzoic acid*, dissolve in 80 ml of *dimethylformamide*, add a few drops of a 1 per cent w/v solution of *thymol blue* in *dimethylformamide* and titrate with the tetrabutylammonium hydroxide solution to a blue end-point. Protect the solution from atmospheric carbon dioxide throughout the titration. Perform a blank determination and make any necessary correction.

1 ml of *0.1 M tetrabutylammonium hydroxide* is equivalent to 0.01221 g of  $C_7H_6O_2$ .

**Titanium Trichloride, 0.1 M:** Dilute 100 ml of *titanium trichloride solution* with 200 ml of *hydrochloric acid* and add sufficient freshly boiled and cooled *water* to produce 1000 ml. Standardise the solution immediately before use by titrating with it, in an atmosphere of carbon dioxide, 25 ml of *0.1 M ferric ammonium sulphate* acidified with *sulphuric acid*, using *ammonium thiocyanate* solution, adjust before the end-point, as indicator.

1 ml of *0.1 M ferric ammonium sulphate* is equivalent to 0.01543 g of  $TiCl_3$ .

**Zinc Chloride, 0.1 M:** Dissolve 6.6 g of *granulated zinc*, previously washed with *0.1 M hydrochloric acid* and then with *water*; in the minimum amount of *2 M hydrochloric acid* and add sufficient *water* to produce 1000 ml. Standardise the solution in the following manner.

To 25.0 ml of the solution add 4 g of *ammonium acetate* and 25 ml of *water*. Add 50 mg of *xylene orange mixture* and sufficient *hexamine*, and titrate with *0.1 M disodium edetate* until the colour changes to yellow.

1 ml of *0.1 M disodium edetate* is equivalent to 0.013630 g of  $ZnCl_2$ .

**Zinc Sulphate, 0.1 M:** Dissolve 29 g of *zinc sulphate* in sufficient *water* to produce 1000 ml. Standardise the solution in the following manner.

To 20.0 ml add 5 ml of *2 M acetic acid* and carry out the method for the determination of zinc (2.3.44).

1 ml of *0.1 M disodium edetate* is equivalent to 0.02875 g of  $ZnSO_4 \cdot 7H_2O$ .



## 5. GENERAL TESTS

5.1.	Cleaning of Glassware	....
5.2.	Biological Indicators	....
5.3.	Sterilisation	....
5.4.	Residual Solvents	....
5.5.	Impurities	....
5.6.	Water for Pharmaceutical Use	....
5.7.	Statistical Analysis of Results	....
5.8.	Dimensions of Hard Gelatin Capsule Shells	....
5.9.	Microbial Quality of Preparations	....
5.10.	Reference Substances (IPRS)	....

## 5.1 Cleaning of Glassware

The success of a test or assay of the Pharmacopoeia is determined to a very large extent by the state of cleanliness of the apparatus used. Glassware such as beakers, burettes, flasks, pipettes, etc. should be very clean, especially when employed for certain microbiological assays, the pyrogen test and where small volumes of liquid are measured.

For cleaning glassware, one of the most useful agents is hot *nitric acid*. A very effective cleaning fluid for removing organic matter from glass without heating is by treatment with a chromic acid mixture prepared by dissolving 200 g of *sodium dichromate* in about 100 ml of *water*, cooling in an ice-bath and adding slowly to it, with stirring, 1500 ml of *sulphuric acid*. The mixture should be prepared in a hard, borosilicate glass beaker and safety glasses must be worn during the addition of acid. Chromic acid mixture is extremely corrosive and hygroscopic, and should be stored in glass-stoppered bottles in a safe place. Crystalline chromic acid tends to separate from the mixture on standing, and may be removed by decantation. When the mixture acquires a green colour, it should be discarded under continuously flowing water.

Glass treated with the chromic acid mixture should be subjected to prolonged rinsing as glass tends to adsorb the chromic acid. It should not be used for cleaning calibrated containers used for optical measurements.

For general cleaning of glassware, synthetic detergent solutions or alkaline cleansing agent such as trisodium phosphate may be used but these also require prolonged rinsing.

All glassware should be finally rinsed with *purified water* before use.

## 5.2. Biological Indicators

### 1. General Requirements

A biological indicator is a microbiological test system consisting of a standardised, viable population of specific micro-organisms (usually bacterial spores) inoculated on a carrier contained within its primary pack ready for use and providing a defined resistance to a specified sterilisation process.

Biological indicators provide means to directly assess the microbial lethality of a sterilisation process. When used in conjunction with physical and/or chemical process monitors, biological indicators provide an indication of the effectiveness of a given sterilisation process. A sterilisation process should be considered as satisfactory only when the desired microbiological results, as determined by an appropriate sterilisation cycle development, validation and routine

monitoring programme, have been realised. Failure to achieve acceptable microbial challenge results forms the basis for declaring a failure in the sterilisation process. Biological indicators may also be used to evaluate the capability of processes used to decontaminate isolators or aseptic clean-room environments.

### 2. Types of Biological Indicators

Biological indicators come in various forms designed for specific types of sterilisation. Each type incorporates a viable culture of a known species of micro-organisms. There are at least three different types of biological indicators. Some biological indicators may also contain two different species and concentrations of spores.

In one form, the spores are inoculated on a carrier of convenience, such as filter paper placed within a primary pack that protects the carrier from damage or contamination while allowing the sterilant to contact the test organisms. Aseptic technique must be employed when transferring the inoculated carrier to the growth medium in order to avoid accidental contamination. The carrier and primary packaging is not degraded by the specific sterilisation process and is designed to minimise any loss of the original inoculum during transport, handling and shelf-life storage.

In another form, called the self-contained biological indicator, the unit consists of both an ampoule of growth medium and an inoculated carrier with the desired population of test organisms, in another vial. The sterilant enters and exits the outer vial through a filter in the cap. This form of biological indicator together with the self-contained growth medium can be considered a system and the entire system provides resistance to the sterilisation process. To allow for the time lag that may occur while the sterilising agent reaches the contained micro-organisms in the system, the *D*-value (Decimal Reduction Value), process end-point kill time and the survival time should be characterised for the system and not solely for the paper carrier of the self-contained unit. Following processing, the ampoule of growth media is crushed and brought into contact with the inoculated carrier, thereby eliminating the need to aseptically transfer the carrier to a separate vial of growth media.

Other self-contained biological indicators consist of hermetically sealed ampoules containing the test organisms suspended in growth media. The growth medium often also contains a dye, which indicates positive or negative growth following incubation. Due to their construction, this type of biological indicator is sensitive to temperature only and is employed primarily for monitoring sterilisation of liquids. These biological indicators may be incubated directly following exposure to the sterilisation process under the specified conditions. Growth or no growth of the treated spores is

determined visually (either by observing a specified color change of an indicator incorporated in the medium or by turbidity) or by microscopic examination of the inoculated medium.

The design of the self-contained system is such that there is minimal loss of the original inoculum during transport and handling and the resistance characteristics comply with the labelling of the self-contained system. During or after the sterilisation process, the materials used in the self-contained system do not retain or release any substance that can inhibit the growth of low numbers of surviving indicator micro-organism under culture conditions. Adequate steps must be taken to demonstrate that the recovery medium has retained its growth support characteristics after exposure to the sterilisation process.

Custom biological indicators for use in sterilisation-in-place (SIP), or wherever necessary, may be prepared by adding an aliquot of spore suspension to representative units of the lot to be sterilised (inoculated product). If it is not practical to add the spores to the actual product units, spores can be added to a simulated product, which has been validated to demonstrate a similar resistance to the actual product. Spore suspensions with a known *D*-value should be used to inoculate the actual or simulated inoculated product. The population, *D*-value (the time required at a temperature *T* to reduce a specific microbial population by 90 per cent, or by a factor of 10), *Z*-value (the number of degrees of temperature change necessary to change the *D*-value by a factor of 10), where applicable, and end-point kill time of the inoculated actual or simulated product should be determined.

### 3. Test Organisms

Test organisms are of a defined strain maintained with a recognised culture collection and identified by appropriate tests.

The preparation of stock spore suspensions of selected micro-organisms requires the development of appropriate procedures, including mass culturing, harvesting, cleaning, and maintenance. The stock suspension contains dormant spores that have been held in a non-nutritive liquid. The originating inoculum for each batch of test organism suspension is traceable to the reference culture maintained at a recognised culture collection. The stock suspension is verified as to its identity and purity. Verification tests are specific for each strain of test organism and should be documented by the manufacturer.

### 4. Labelling

Each batch of biological indicator is accompanied by the following information:

- 1) name of the biological indicator and intended sterilisation process;
- 2) a unique code by which the manufacturing history can be traced;
- 3) the manufacturer's name, trademark, address or other means of identification;
- 4) the name or abbreviation of the culture collection from which the test organism has been derived and the reference number of the species;
- 5) the recommended storage conditions, such as, preserving in the original package under the conditions recommended on the label and protecting from light, toxic substances, excessive heat and moisture;
- 6) the expiry date that is not less than 18 months from the date of manufacture, the date of manufacture being the date on which the first determination of the total viable spore count was made;
- 7) the total viable spore count of test organisms per unit;
- 8) the directions for use including incubation conditions, instructions for spore recovery and for safe disposal of the indicator;
- 9) *D*-value and the method used to determine such *D*-value, i.e., by survivor curve or fraction negative procedure after graded exposures to the sterilisation conditions.
- 10) indication that the stated *D*-value is reproducible only under the exact conditions under which it was determined, that the user would not necessarily obtain the same result, and that the user should determine the suitability of the biological indicator for the particular use;
- 11) the survival time and kill time under the specified sterilisation conditions stated on the label.

### 5. Selection for Specific Sterilisation Processes

The selection of a biological indicator is critical and requires that due weightage be given to the resistance of the biological indicator, to the specific sterilisation process and the material being sterilised so that when used within its performance characteristics, it provides a challenge to the sterilisation process that exceeds the challenge of the natural microbial burden in or on that product.

The effective use of biological indicators for the monitoring of a sterilisation process requires a thorough knowledge of the product being sterilised and its component parts (materials and packaging). It also requires at least a general idea of the probable types and numbers of micro-organisms constituting the microbial burden in the product immediately prior to sterilisation.

Only the biological indicator specified for that particular sterilisation process should be used. This will ensure that the

biological indicator selected provides a greater challenge to the sterilisation process than the bioburden in or on the product.

When a bioburden-based sterilisation process design is used, data comparing the resistance of the biological indicator to that of bioburden are essential. Enumeration of the bioburden content of the articles being sterilised is also required. The process must result in a biologically verified lethality sufficient to achieve a probability of obtaining a nonsterile unit that is less than one in a million.

Alternatively, the overkill method may be used in the design of a sterilisation process. In this case, specific assumptions are made regarding the resistance used in establishing sterilisation process lethality requirements. In general, all overkill processes are built upon the assumption that the bioburden is equal to one million organisms and that the organisms are highly resistant. Thus, to achieve the required probability of a nonsterile unit that is one in a million, a minimum 12D process is required. A 12D process is defined as a process that provides lethality sufficient to result in a 12-log reduction, which is equivalent to slightly greater than 12 times a D-value for organism with sufficiently higher resistance than the mean resistance of bioburden. Because the bioburden is assumed to be one million, an overkill process will result in a probability of nonsterility at much less than  $10^{-6}$  in actual practice. Overkill process design and evaluation may differ depending upon the sterilisation process under test. The use of an overkill design and validation approach may minimise or reduce the need for bioburden enumeration and identification.

## 6. Dry Heat Sterilisation Processes

**6.1 Test organism.** Spores of *Bacillus atrophaeus* (*Bacillus subtilis* var. *niger*) (ATCC 9372; NCIMB 8058; CIP 77.18) are used for validation and routine monitoring of the performance of sterilisers and sterilising processes employing dry heat at sterilising temperatures, typically at 160°. For routine monitoring, the D-value shall not be less than 2.5 minutes.

**6.2 Identification.** The biological indicator organism complies substantially with the morphological, cultural and biochemical characteristics of the strain of *Bacillus atrophaeus* ATCC 9372; under microscopic examination it consists of Gram-positive rods of width 0.7 µm to 0.8 µm, and length 2 µm to 3 µm, the endospores are oval and central and the cells are not swollen; when incubated aerobically in appropriate media at 30° to 50° growth occurs within 24 hours and similar inoculated media incubated concomitantly at 55° to 60° show no evidence of growth in the same period; agar colonies have a dull appearance and may be cream to brown to orange-coloured; when incubated in nutrient broth it develops a pellicle, and shows little or no turbidity.

**6.3 Biological Indicator.** The indicator used is Biological Indicator for dry-heat Sterilisation, paper carrier. It is a defined

preparation of viable spores made from a culture derived from a specified strain of *Bacillus atrophaeus*, on a suitable grade of paper carrier, individually packaged in a container readily penetrable by dry heat, and characterised for predictable resistance to dry-heat sterilisation. It has a particular labelled spore count per carrier of not less than  $10^4$  and not more than  $10^8$ .

## 7. Ethylene Oxide Sterilisation Processes

**7.1 Test organism.** Spores of *Bacillus atrophaeus* (ATCC 9372; NCIMB 8058; CIP 77.18) are used for validating and assessing the routine performance of sterilisers and sterilising processes employing ethylene oxide, either as pure ethylene oxide gas or as a mixture of this gas with diluent gases at sterilising temperatures within the range of 30° to 65° and 50 to 70 per cent relative humidity. For routine monitoring, the D-value shall be not less than 2.5 minutes at  $54^\circ \pm 1^\circ$ ; 60 per cent  $\pm 10$  per cent RH and 600 mg  $\pm 30$  mg/l EO

**7.2 Identification.** The biological indicator organism complies substantially with the morphological, cultural and biochemical characteristics of the strain of *Bacillus atrophaeus*, ATCC No. 9372, described under Dry heat sterilisation processes.

**7.3. Biological indicators.** Either of the following may be used.

**7.3.1 Biological Indicator for Ethylene Oxide Sterilisation, Paper Carrier.** It is a defined preparation of viable spores made from a culture derived from a specified strain of *Bacillus atrophaeus* on a suitable grade of paper carrier, individually packaged in a suitable container readily penetrable by ethylene oxide sterilizing gas mixture and characterized for predictable resistance to sterilization with such gas mixture. It has a particular labelled spore count per carrier of not less than  $10^4$  and not more than  $10^8$  spores.

**7.3.2 Biological Indicator for Ethylene Oxide Sterilisation, Self-contained.** It consists of a *Biological indicator for ethylene oxide sterilisation, paper carrier* in a suitable container readily penetrable by ethylene oxide sterilising gas mixture and designed to hold an appropriate bacteriological culture medium in a separate ampoule inside the container. After subjection to ethylene oxide sterilisation conditions, the ampoule of growth medium is suitably crushed so as to enable the paper carrier to be immersed and incubated in the growth medium which contains a suitable indicator for determining by a colour change whether or not spores have survived.

## 8. Moist Heat Sterilisation Processes

**8.1 Test organism.** Spores of suitable strains of *Geobacillus stearothermophilus* (*Bacillus stearothermophilus*) (ATCC 7953 & 12980; NCTC 10003; NCIMB 8157; CIP 52.81) are used for validating and assessing routine performance of sterilisers and sterilising processes employing moist heat as the



sterilising agent at temperatures of 121°. For routine monitoring, the  $D_{121}$  value shall be not less than 1.5 minutes.

For processes where the temperature employed is less than 121° (sterilisation of heat-sensitive liquids or containers etc.) micro-organisms such as *Bacillus subtilis* “5230” may be used.

**8.2 Identification.** The biological indicator organism complies substantially with the morphological, cultural and biochemical characteristics of the strain of *Geobacillus stearothermophilus* that is stated in the labelling: under microscopic examination it consists of Gram-positive rods with oval endospores in subterminally swollen cells. When incubated in nutrient broth for 17 hours and used to inoculate appropriate solid media, growth occurs when the inoculated media are incubated aerobically for 24 hours at 55° to 60°, and similar inoculated media incubated concomitantly at 30° to 35° show no evidence of growth in the same period.

**8.3 Biological Indicators.** Any of the following may be used.

#### 8.3.1 Biological Indicator for Steam Sterilisation, Paper Carrier

It is a defined preparation of viable spores made from a culture derived from a specified strain of *Geobacillus stearothermophilus* on a suitable grade of paper carrier, individually packed in a suitable container readily penetrable by steam and characterised for predictable resistance to steam sterilisation. It has a particular labelled spore count per carrier of not less than  $10^4$  and not more than  $10^8$  spores.

#### 8.3.2 Biological Indicator for Steam Sterilisation, Self-contained

It consists of a *Biological Indicator for Steam Sterilisation, Paper Carrier* individually packaged in a suitable container readily penetrable by steam and designed to hold an appropriate bacteriological culture medium in a separate

ampoule. After subjection to saturated steam sterilisation conditions, the ampoule of growth medium is suitably crushed so as to enable the paper carrier to be immersed and incubated in the growth medium which contains a suitable indicator for determining by a colour change whether or not spores have survived.

#### 8.3.3 Biological Indicator for Steam Sterilisation, Sealed Ampoule

It is a defined preparation of viable spores made from a culture derived from a specified strain of *Geobacillus stearothermophilus* which is inoculated into an appropriate bacteriological growth medium, and hermetically sealed in a suitable container. It is sensitive to temperature only and primarily used for steam sterilisation of liquids. After subjection to saturated steam sterilisation conditions, the ampoule is incubated at the specified temperature. The growth medium contains a suitable indicator for determining by a colour change whether or not spores have survived.

### 9. Characteristics of Biological Indicators

#### 10. Ionizing Radiation Sterilising Processes

Spores of *Bacillus pumilus* (ATCC 27142) or other strains or microorganisms of demonstrated equivalent performance are used for validating and assessing routine performance of sterilisers and sterilising processes employing ionising radiation in the form of gamma radiation from a suitable radioisotope source such as Cobalt-60 or Cesium-137 or of electrons energised by a suitable electron accelerator, as the sterilising agent. It has a labelled spore count of not less than  $1.0 \times 10^7$  and the  $D$ -value shall be in the range of 0.15 to 0.20 Mrad (1.5 to 2.0 kGy).

For gamma radiation sterilisation, an effective sterilising dose of about 25kGy (2.5 Mrads) is considered a safe overkill approach. If doses less than 25 kGy are used, additional

Some characteristics of commercially available biological indicators

Sterilisation Mode	Example of a typical $D$ -value (minutes)	Minimum $D$ values for selecting a suitable biological indicator (minutes)	Minimum survival time (minutes)	Kill time (minutes)
Dry Heat 160°	1.9	Min 1.0 Max 3.0	Min 4.0 Max 14.0	Min 10.0 Max 12.0
Ethylene oxide 600 mg per litre 54°, 60 per cent relative humidity	3.5	Min 2.5 Max 5.8	Min 10.0 Max 27.0	Min 25.0 Max 68.0
Moist Heat 121°	1.9	Min 1.5 Max 3.0	Min 4.5 Max 14.0	Min 13.5 Max 32.0

microbiological monitoring of the product before irradiation will be necessary. In order to validate the efficacy, particularly of the lower exposure levels, it is necessary to determine the magnitude (number and/or degree) of the natural radiation resistance of the microbial population of the product.

Radiation dose-setting methods that do not use biological indicators have also been widely used to establish radiation sterilisation processes and effective measurement of the delivered dose can be monitored by physical dosimeters.

### 11. Vapour-phase Hydrogen Peroxide (VPHP) Sterilising Processes

Spores of *Geobacillus stearothermophilus* are used for validating and assessing the routine performance of sterilisers and sterilising processes employing VPHP. Other micro-organisms that may be useful as biological indicators in VPHP processes are spores of *Bacillus atrophaeus* and *Clostridium sporogenes*. Other micro-organisms may be considered if their performance responses to VPHP are similar to those of the microorganisms cited above.

The spores may be inoculated on the surface of various carrier systems composed of glass, metal, or plastic surfaces. Highly absorbent surfaces, such as fibrous substrates, or any other substrates that readily absorb VPHP or moisture may adversely influence the VPHP concentration available for inactivation of inoculated micro-organism. Paper substrates are not used because VPHP will degrade cellulose-based materials.

The biological indicator may also be individually packaged in a suitable primary overwrap package that does not adversely affect the performance of the indicator, and is penetrable by VPHP. The overwrap materials may facilitate laboratory handling of the biological indicators following exposure to VPHP and must be carefully assessed to ensure that following VPHP exposure, residual hydrogen peroxide is not retained by the packaging materials possibly inducing bacteriostasis during the recovery steps. In cases where biological indicators (inoculated carriers) are being used without the primary package, stringent adherence to aseptic techniques is required.

### 12. Performance Evaluation of Biological Indicators

**12.1 General.** When biological indicators are purchased from a commercial source, their suitability for use in a specific sterilisation process should be established through developmental sterilisation studies unless existing data are available to support their use in the process.

Evaluation of the biological indicator must be performed at the time of each validation exercise or with a new lot number or with a change in vendor/manufacturer of biological indicators. The user should establish in-house acceptance standards for biological indicator lots and consider rejection

in the event the biological indicator lot does not meet the established in-house performance standards.

The manufacturer's Certificate of Analysis relative to *D*-value range, storage conditions, expiration date, and stability of the biological indicator should be observed and noted. If certificates are not obtained and audits have not been performed, or if the biological indicators are to be used outside of the manufacturer's label claims, verification and documentation of performance under conditions of use must exist.

Upon initial receipt of the biological indicator from a commercial supplier, the user should verify the morphology of the purchased biological indicator micro-organism. A microbial count to determine the mean count per biological indicator unit should be conducted.

**12.2 Purity.** By examination of the spores on a suitable plate culture medium, there should be no evidence of contamination with other micro-organisms that will adversely affect the performance of the indicator organism.

**12.3 Resistance performance tests.** Proceed as given in 15. Resistance Performance Tests.

### 12.4 Medium Suitability in Self-contained Biological Indicators

**12.4.1 Sterility** – Incubate 10 self-contained biological indicator systems at the optimal recovery temperature specified by the manufacturer for 48 hours, making sure that there is no contact between the individual inoculated spore paper carrier and the supplied growth medium. Examine the incubated medium visually (for change in color indicator or turbidity) and microscopically (for absence of microbial growth).

**12.4.2 Growth promotion of medium prior to sterilisation treatment** – Submerge 10 self-contained units in a water bath maintained at 95° to 100° for 15 minutes. Cool rapidly in an ice water-bath at 0° to 4°. Remove the units from the ice water-bath, immerse the paper carrier in the self-contained medium and incubate at the optimal temperature specified by the manufacturer. Examine visually after 48 hours. All the specimens under test show growth. If one or more specimens do not show growth, repeat the test with 20 additional units.

**12.4.3 Ability of medium to support growth after exposure to the sterilisation conditions** – Take 10 units after they have been exposed for a kill time as stated in the Certificate of Analysis. Aseptically remove and pool the medium from each unit. Prepare a suspension of the indicator micro-organism as directed for Total Viable Spore Count in Appendix 9.7. Prepare a dilution of that suspension and inoculate the pooled medium with enough suspension to contain a total of 100 to 1000 micro-organisms in a 10 ml aliquot obtained from the pooled volume. Incubate the inoculated pooled medium at the optimal

temperature specified by the manufacturer. Clear evidence of growth is obtained within 7 days.

### 13. Use for Validation of Sterilisation Processes

Regardless of the mode of sterilisation, the amount of the initial population of the micro-organisms, its resistance to sterilisation and the site of inoculation on or in the product can all influence the rate of biological indicator inactivation.

During microbial challenge, biological indicators should be placed in different pre-identified locations of the product/materials to be sterilised. If, for example, a container with a closed system is sterilised, both the product solution and the closure should be challenged to ensure that sterilisation equivalent to a  $10^{-6}$  (one in a million probability of a non sterile unit) sterilisation assurance level (SAL) will be obtained in the solution as well as at the closure site. Depending on the locations of the product components most difficult to sterilise, different process parameters may be involved in assuring microbial inactivation to an SAL of  $10^{-6}$ .

The validation phase should identify the most important process parameters for inactivation of micro-organisms at the sites most difficult to sterilise. Once these critical processing parameters are determined during validation of the product, they should be operated at the lowest acceptable conditions stated in the sterilisation process specifications.

Considerations leading to different intervals for validation of the sterilisation process could include seasonal changes, product and material changes as well as equipment changes, etc.

### 14. Use for Routine Monitoring of Sterilisation Processes

**14.1 Procedure.** Place the biological indicators in the locations determined during the validation process for specific product loads.

After completion of the sterilisation procedure for Biological Indicator for dry heat sterilisation, paper carrier; Biological Indicator for ethylene oxide sterilisation, paper carrier and Biological indicator for steam sterilisation, paper carrier, whichever is applicable, aseptically remove each paper carrier and add to a sufficient volume of *soyabean-casein digest medium* to submerge the biological indicator in a suitable tube.

For *biological indicator for ethylene oxide sterilisation, self-contained and biological indicator for steam sterilisation, self-contained*: Crush the self-contained system suitably according to manufacturer's instructions, so as to enable the paper carrier to submerge completely in the growth medium.

Incubate at a temperature of 30° to 35° for *biological indicator for dry heat sterilisation* and *biological indicator for ethylene oxide sterilisation*, or at 55° to 60° for *biological indicator for steam sterilisation*, or in each case at the optimal recovery temperature specified by the manufacturer.

Observe each inoculated medium containing tube, self-contained or sealed ampoule at 24 hours and 48 hours, and every 1 or 2 days thereafter for a total of 7 days of incubation or for the time specified by the manufacturer for products that yield results in less than 7 days. Regardless of self-contained biological indicator or not, growth/no growth should be interpreted according to manufacturers' instructions. Where growth is observed at any particular observation time, further incubation of the specimen(s) concerned is not necessary. Note the specimens showing no evidence of growth at any time.

**14.2 Results.** A sterilisation process in which all the validated pre-set parameters have been met should show no growth of the biological indicator.

A sterilisation process where validated pre-set minimum parameters have not been met could show growth of the biological indicator.

A sterilisation process where only some of the process parameters have been met might or might not show growth of the indicator.

Actions to be taken upon growth of a biological indicator subsequent to sterilising processing may vary with institutional and regulatory policies, and may require that the lot of the product be rejected as non-sterile. The identification of growth as that of the test organism should be confirmed and an effort made to identify the cause of growth. Consistent growth of biological indicators subsequent to sterilization may indicate a loss of integrity of the sterilisation process or an unusually high resistance of the biological indicator lot under use. If an investigation of the biological indicator indicates no significant change in the biological indicator that affects its performance in the sterilisation process, then the sterilisation process should be requalified.

Any biological indicator test results that show growth of the indicator when no growth would be expected may be an indication of an invalid process, a defective biological indicator or a faulty test system and should lead to an investigation. Unsuitable systems shall be requalified. The identity of the indicator organism should be confirmed for positive biological indicators. If the identity is confirmed, the result should be interpreted as an incomplete sterilisation of the product lot, unless investigation of the biological indicator failure can prove otherwise.

Cultures showing growth that is not confirmed to be the indicator organism should be further investigated to determine the cause of the positive result. Frequent test contaminants may indicate a faulty test system or inadequate training of personnel.

Systems should be established to detect any untoward deviations. This can be achieved by establishing routines for growth promotion tests of the medium or introducing positive

controls and tests, as well as, for example, establishing routines for controlling the temperature of the incubator.

The process should be considered acceptable only when the desired physical and/or chemical parameters have been reviewed and the microbiological results interpreted and both found to comply with the desired criteria.

**14.3 Disposal.** Prior to destruction or discard, sterilise it by steam at 121° for not less than 30 minutes, or by not less than an equivalent method recommended by the manufacturer. This includes a paper carrier used in any test procedures or the paper carriers themselves.

## 15. Resistance Performance Tests

**15.1 Total viable spore count.** This test is used to determine the number of viable test organisms both in suspensions and in paper carriers by counting colony-forming units (CFUs). It applies to both unprocessed (initial viable count) and processed (viable organisms when using the survivor curve method for *D*-value determination) test samples.

A minimum of four test samples from each lot/batch or exposure shall be used. A homogeneous suspension may be achieved using the following method (glass bead method):

Remove the paper carrier from its original packing and place it in a sterile flat-bottomed, screw-capped 16 x 125 mm test-tube containing three 6-mm glass beads. Add 5.0 ml of sterilised *purified water* and pulp the paper into its component fibres by vortexing vigorously to achieve a homogeneous suspension. Add an additional 5.0 ml of sterilised *purified water*.

Transfer 1.0 ml of the suspension using a pipette with a bore size of at least 2 mm, to a sterile screw-capped 16 x 125 mm test-tube containing 9.0 ml of sterile *purified water*. For *biological indicator for steam sterilisation*, heat the tube containing the homogeneous suspension in a water- or glycol-bath at 95° to 100° for 15 ± 1 minutes. Start the timing when the temperature reaches 95°. For *biological indicator for ethylene oxide sterilisation* or *biological indicator dry heat sterilisation*, heat the tube containing the homogeneous suspension in a water- or glycol-bath at 80° to 85° for 10 minutes. Start the timing when the temperature reaches 80°. Cool rapidly in an ice water-bath at 0° to 4°.

Transfer two 1-ml aliquots of the suspension using a pipette with a bore size of at least 2 mm to duplicate tubes containing 9.0 ml of sterile *purified water*. Make appropriate serial dilutions in sterile *purified water*, the dilutions being adjusted to yield between 30 and 300 colonies, on each of a pair of plates when treated as described below. Where the biological indicator has a low spore concentration, it may be necessary to modify the dilution series and to use more plates at each dilution.

Prepare a separate series of plates for each aliquot. Place 1.0 ml of each selected dilution in each of two Petri dishes 9 to 10 cm in diameter. Add to each plate 20 ml of *casein- soyabean digest agar medium* that has been melted and cooled to 55°. Swirl to attain a homogeneous suspension and allow to solidify. Incubate the plates in an inverted position at 55° to 60° for *biological indicator for steam sterilisation* and at 30° to 35° for *biological indicator for ethylene oxide sterilisation* or *biological indicator for dry heat sterilisation*, or at the optimal recovery temperature specified by the manufacturer of the biological indicator. Incubate for 48 to 72 hours. Units incubated at 55° to 60° may be placed inside a plastic bag to prevent the plates from excessive drying.

Examine the plates after 24 and 48 hours, recording for each plate the number of colonies, and using the number of colonies after 48 hours to calculate the results. Calculate the average number of spores per sample from the results, using the appropriate dilution factor.

For *biological indicators, sealed ampoule*, take 4 ampoules in a sterile 125-ml screw-capped glass bottle and break the ampoules by shaking against the sides of the bottle. Add sufficient sterile *purified water* to make 100.0 ml and vortex or sonicate vigorously to achieve a homogeneous suspension. Transfer 10.0 ml to a sterile 16 x 125 mm screw-capped tube. Carry out the procedure described above beginning at the words “Transfer 1.0 ml of the suspension.....”.

The requirements of the test are met if the log average number of the viable spores per carrier is not less than 0.3 log and does not exceed the log labelled spore count per carrier by 0.48.

**2. Determination of *D*-Value.** Users of biological indicators are generally not required to perform resistance assays but they may have differing requirements for their quality assurance systems. The requirement to perform *D*-value confirmation testing can be eliminated by an appropriate audit of the manufacturer of the biological indicator. This can be accomplished in one of three ways viz. a personal audit by the user of the facilities of the manufacturer of the indicator, performance of a “mail-in” audit, or confirmation by the indicator manufacturer that an audit has been performed by a notified body (e.g., certification of comparison to standards ISO 10011-1, 10012-1 and 10011-3).

A Certificate of Analysis that a biological indicator conforms to a specific resistance characteristic is required. If certificates are not obtained and audits have not been performed, or if the biological indicators are to be used outside of the manufacturer’s label claims, verification and documentation of resistance performance, under conditions of use, must be confirmed.

The user may consider conducting a *D*-value assessment before acceptance of the lot. Laboratories that have the



capability of performing *D*-value assays may determine the *D*-value using the method cited in ISO document *ISO 11138-1:1994(E) Annexes C and/or D*. If the user elects to reconfirm the *D*-value specified on the Certificate of Analysis, testing must be by the method used by the manufacturer.

**3. Survival time and Kill time.** When labelled for and subjected to a specified sterilisation, a biological indicator has a survival time and kill time appropriate to the labelled spore count and to the decimal reduction value (*D*-value in minutes) of the indicator, specified as:

Survival time (in minutes) = not less than (labelled *D*-value x (log labelled spore count per carrier – 2));

Kill time (in minutes) = not more than (labelled *D*-value x (log labelled spore count per carrier + 4)).

**3.1 Procedure.** Take four groups, each consisting of 25 specimens of the relevant biological indicator, in their original individual packages. Place the specimens of each group in suitable specimen holders that permit each specimen to be exposed to the sterilising conditions at a specific location in the sterilising chamber. Check the chamber for operating parameters by preheating it to the selected temperature  $\pm 1^\circ$  in the cases of *biological indicator for dry heat sterilisation*, and *biological indicator for ethylene oxide sterilisation* or  $\pm 0.5^\circ$  in the case of *biological indicator for steam sterilisation*.

For *biological indicator for dry heat sterilisation*, preheat the unit to temperature, and equilibrate the heat chamber. Open the access door or port, and place the holder(s) in the chamber, close the access door or port, and continue to operate the apparatus. Commence timing the heat exposure when the chamber temperature returns to the lower limit of the selected temperature. Expose the first group of 25 specimens for the required survival time, enter the chamber, and remove the holder(s) containing the specimens. Repeat this test with the second group of 25 specimens. Repeat the above procedure immediately, or preheat if a substantial interval has elapsed, with the last two groups, each consisting of 25 specimens, similarly, but expose the specimens for the required kill time.

For *biological indicator for ethylene oxide sterilisation*, preheat the chamber to equilibrium at the selected temperature  $54 \pm 1^\circ$ , and proceed as follows:

1. Evacuate the test chamber to a pressure of not more than  $100 \pm 3$  mm of mercury.
2. Inject sufficient water vapor (e.g. saturated steam) to bring the chamber contents to within 10 per cent relative humidity of the required humidification condition, and allow the chamber to equilibrate with moisture and to temperature for about 30 minutes.
3. Inject a sufficient quantity of temperature-equilibrated ethylene oxide gas to attain the appropriate concentration of  $\pm 30$  mg of ethylene oxide per litre.

4. Subject a group of specimens to the appropriate temperature, humidification, and gas concentration conditions for the required survival time.
5. Evacuate the test chamber to a pressure of  $100 \pm 3$  mm of mercury, and release the vacuum with sterile filtered air. Repeat this until not less than 99 per cent of the remaining gas has been removed, and remove the holder(s) with the exposed specimens.

Repeat the above procedure with the second group of 25 specimens and the last two groups each consisting of 25 specimens, similarly, but using a gassing time in step (4) appropriate to the required kill time.

For *biological indicator for steam sterilisation, paper carrier* and *biological indicator for steam sterilisation, sealed ampoule*, exhaust the steam chamber and open the door. Within 15 seconds of opening the door place the loaded holder(s) into the chamber, and operate the apparatus to heat the chamber contents to  $121^\circ$  in less than 10 seconds. Expose the specimens for the required survival time, counting the exposure time from when the temperature record shows that the chamber has reached the required temperature. Exhaust the chamber in less than 10 seconds at the end of exposure period. When the chamber can be safely entered, remove the holder(s) containing the specimens. Repeat the above procedure immediately, or preheat if a substantial interval has elapsed, so as to subject the holder(s) containing 25 specimens similarly to the first exposure. Repeat the above procedure with two more groups each consisting of 25 specimens, similarly, but expose the specimens for the calculated kill time.

**3.2 Recovery.** After completion of the sterilisation procedure incubate all biological indicators. All self-contained biological indicators should be activated as necessary and incubated in their own medium. For all other biological indicators, aseptically remove each spore carrier and add to a sufficient volume of *soyabean-casein digest medium* to submerge the carrier in a suitable tube Use an incubation temperature of  $30^\circ$  to  $35^\circ$  in the cases of *biological indicator for dry heat sterilisation* and *biological indicator for ethylene oxide sterilisation, paper carrier*, and  $55^\circ$  to  $60^\circ$  in the case of *biological indicator for steam sterilisation*, or at the optimal temperature specified by the manufacturer.

Observe each inoculated medium tube daily for the length of time specified by the manufacturer. If no time is specified, incubate for 7 days after inoculation. Growth/no growth should be interpreted according to the manufactures' instructions. Where growth is observed at any particular observation time, further incubation of the specimen(s) is not necessary. Note the number of specimens showing no evidence of growth at each observation as well.

The requirements of the test are met if all of the specimens subjected to the specified sterilisation for the survival time

show evidence of growth, while none of the specimens subjected to the specified sterilisation for the kill time shows growth.

If for either the survival time test or the kill time test, not more than one specimen out of both groups fails the survival requirements or the kill requirements (whichever is applicable), repeat the corresponding test with four additional groups each consisting of 20 specimens, according to the procedure described. If all of the additional specimens subjected to the specified process either meet the survival requirement for the survival time or meet the kill requirement for the kill time test, whichever is applicable, the requirements are met.

### 5.3. Sterilisation

Sterility is the total absence of viable micro-organisms. Absolute sterility cannot be practically demonstrated without complete destruction of every finished article. The sterility of a lot purported to be sterile is therefore defined in probabilistic terms, where the likelihood of a contaminated unit or article is acceptably remote. The sterility of an entire lot of finished compendial article cannot be guaranteed by testing; it has to be assured by the application of a suitably validated production process. Such a process would involve the use of adequate sterilisation cycles and subsequent aseptic processing, if any, under appropriate good manufacturing practices, and not by reliance solely on sterility testing. The design of the process should include the use of:

- qualified personnel with appropriate training,
- adequate premises,
- suitable production equipment, designed for easy cleaning and sterilisation,
- adequate precautions to minimize the bioburden prior to sterilisation,
- validated procedures for all critical production steps,
- environmental monitoring and in-process testing procedures.

The precautions necessary to minimize the pre-sterilisation bioburden include the use of components with an acceptable degree of microbial contamination. Microbiological monitoring and setting of suitable acceptance or action limits may be required for ingredients that are liable to be contaminated because of their origin, nature or method of preparation.

Failure to follow meticulously a validated process involves the risk of a non-sterile product or even of a deteriorated product.

*NOTE — The methods described here apply mainly to the inactivation of bacteria, yeasts and moulds. For biological products of animal or human origin or in cases where such*

*material has been used in the production process, it is necessary during validation to demonstrate that the process is capable of removing or inactivating relevant viral contamination.*

The basic steps of validation of a sterilizing process consist of:

1. Qualifying the process equipment in order to demonstrate that it has the capability of operating within the required parameters.
2. Demonstrating that the critical control equipment and instrumentation are capable of operating within the prescribed parameters for the process equipment.
3. Performing replicate cycles representing the required operational range of the equipment and employing actual or simulated product and demonstrating that the processes have been carried out within the prescribed protocol limits and that the probability of microbial survival in the replicate processes completed is not greater than the prescribed limits.
4. Monitoring the validated process during routine operation.
5. Requalifying and rectifying the equipment periodically, as needed.
6. Completing the protocols, and documenting the above-stated steps.

Proper validation of the sterilisation process or the aseptic process requires a high level of knowledge of the field of sterilisation and clean room technology. To meet the currently acceptable and achievable limits in sterilisation parameters, it is essential to employ appropriate instrumentation and equipment to control the critical parameters such as temperature and time, humidity, and sterilising gas concentration, or absorbed radiation.

Given below is a typical multi-stage validation programme designed for steam sterilisation, but the same principles apply to other sterilisation procedures. A vital aspect of the validation programme in many sterilisation procedures is the use of biological indicators (see 5.2. Biological Indicators).

Validation begins with the qualification of the sterilising equipment. The installation qualification stage is intended to establish that controls and other instrumentation are properly designed and calibrated. There should be documented evidence of the quality of the required utilities such as water, steam, and air. The operational qualification stage is intended to confirm that the empty chamber functions within the parameters of temperature at all key positions of the chamber prescribed in the validation protocol. Heat profile records using multiple temperature-sensing devices and indicating simultaneous temperatures in the chamber are created. A typical

acceptable range of temperature in the empty chamber is  $\pm 1^\circ$  when the chamber temperature is not less than  $121^\circ$ . The performance qualification stage of the validation programme is the actual sterilisation of materials or articles. This determination requires the use of temperature-sensing devices inserted into samples of the articles as well as either samples of the articles to which appropriate concentrations of suitable test micro-organisms have been added, or separate biological indicators in operationally fully-loaded autoclave configurations. The effectiveness of heat delivery or penetration into the actual articles and the time of exposure are the two main factors that determine lethality of the sterilization process. The final stage of the validation programme requires the documentation of the data developed in executing the programme.

The validated process should be revalidated periodically; however, the revalidation programme need not be as extensive as the original one. Revalidation is also required whenever major changes in the sterilisation procedure, including changes in the load, take place.

### 1. Sterility Assurance Level (SAL)

The achievement of sterility within any one item in a population of items submitted to a sterilisation process cannot be guaranteed nor can it be demonstrated. The inactivation of micro-organisms by physical or chemical means follows an exponential law; thus, there is always a finite statistical probability that a micro-organism may survive the sterilising process. For a given process, the probability of survival is determined by the number, types and resistance of the micro-organisms present and by the environment in which the organisms exist during treatment. The sterility assurance level (SAL) of a sterilising process is the degree of assurance with which the process in question renders a population of items sterile. The SAL for a given process is expressed as the probability of a non-sterile item in that population. An SAL of  $10^{-6}$ , for example, denotes a probability of not more than one viable micro-organism in  $1 \times 10^6$  sterilised items of the final product. The SAL of a process for a given product is determined by appropriate validation studies.

### 2. Sterilisation

Wherever possible, a process in which the product is sterilised in its final container (terminal sterilisation) is chosen. If terminal sterilisation is not possible, filtration through a bacteria-retentive filter or aseptic processing should be used; wherever possible, appropriate additional treatment of the product (e.g. heating of the product) in its final container may be applied. In all cases, the container and closure are required to maintain the sterility of the product throughout its shelf-life.

It is generally accepted that terminally sterilised injectable articles attain an SAL level of  $10^{-6}$ . With heat-stable articles,

the approach often is to considerably exceed the critical time necessary to achieve the  $10^{-6}$  microbial survival probability (overkill). However, with an article where excessive heat exposure is likely to damage the product, it may not be feasible to employ this overkill approach. In such cases, the development of the sterilisation cycle depends heavily on knowledge of the microbial burden of the product. Where the  $D$ -value [the time in minutes required to reduce the microbial population by 90 per cent or 1 log cycle (i.e., to a surviving fraction of 1/10), at a specific temperature] of a biological indicator preparation of, for example *Bacillus stearothermophilus* spores is 1.5 minutes under the total process parameters, e.g., at  $121^\circ$ , if it is treated for 12 minutes under the same conditions, it can be stated that the lethality input is  $8D$ . The effect of applying this input to the product would depend on the initial microbial burden. Assuming that its resistance to sterilisation is equivalent to that of the biological indicator, if the microbial burden of the product in question is  $10^2$  micro-organisms, a lethality input of  $2D$  yields a microbial burden of 1 ( $10^0$  theoretical) and a further  $6D$  yields a calculated microbial survivor probability of  $10^{-6}$ . Under the same conditions, a lethality input of  $12D$  may be used in a typical "overkill" approach. For valid use, it is essential that the resistance of the biological indicator be greater than that of the natural microbial burden of the article sterilised. In the above example, a 12-minute cycle is considered adequate for sterilisation if the product had a microbial burden of  $10^2$  micro-organisms. However, if the indicator originally had  $10^6$  micro-organisms content, actually a  $10^{-2}$  probability of survival could be expected; i.e. 1 in 100 biological indicators may yield positive results. This type of situation may be avoided by selection of the appropriate biological indicator. Alternatively, high content indicators may be used on the basis of a predetermined acceptable count reduction.

Any microbial burden method for sterility assurance requires adequate surveillance of the microbial resistance of the article to detect any changes, in addition to periodic surveillance of other attributes.

### 3. Methods of Sterilisation

Sterilisation may be carried out by one of the methods described below. The choice of the appropriate method for an article requires a high level of knowledge of sterilisation techniques and information regarding any effects of the sterilising process on the material being sterilised. Modifications to, or combination of, the methods given may be used provided that the chosen procedure is validated both with respect to its effectiveness and the integrity of the product including its container or package.

For all methods of sterilisation the critical conditions of the operation are monitored in order to confirm that the previously determined required conditions are achieved throughout the

batch during the sterilisation process. This applies even in cases where the reference conditions are used.

**3.1 Steam sterilisation (Heating in an autoclave):** This process of thermal sterilisation using saturated steam under pressure should be used whenever possible for aqueous preparations and for surgical materials. The process is based on the principle of displacing the air in the sterilising chamber (autoclave) by saturated steam and continuing the exposure to saturated steam for a period of time sufficient to ensure that the entire articles being sterilised are maintained for an effective combination of time and temperature to ensure sterility. In order to displace air more effectively from the chamber and from within the articles, the sterilisation cycle may include air and steam evacuation stages. The choice of a cycle for any article depends on a number of factors, including the heat lability of the material, knowledge of heat penetration into the articles, and other factors. The reference conditions for aqueous preparations are heating at a minimum of 121° for 15 minutes. Other combinations of time and temperature may be used provided that it has been satisfactorily demonstrated that the process chosen delivers an adequate and reproducible level of lethality when operating routinely within the established tolerances. The procedures and precautions employed should be such as to give an SAL of 10<sup>-6</sup> or better.

In establishing the sterilisation cycle parameters the F<sub>0</sub> concept may be used. The F<sub>0</sub> at a particular temperature other than 121°, is the time (in minutes) required to provide the lethality equivalent to that provided at 121° for a stated time. In general for aqueous preparations a microbiologically-validated steam sterilisation process that delivers, in total (including the heating up and cooling down phases of the sterilising cycle), an F<sub>0</sub> value of not less than 8 to every container in the autoclave load is considered satisfactory. If a product is especially heat-sensitive or in certain circumstances where a process that delivers, in total, an F<sub>0</sub> less than 8 is necessary, great care must be taken to ensure that an SAL of 10<sup>-6</sup> or better is consistently achieved.

When surgical materials are sterilised the steam used should neither be superheated nor contain more than 5 per cent of entrained moisture. Appropriate steps should be taken to ensure adequate removal of air. Most dressings are conveniently sterilised by maintaining at a temperature of 134° to 138° for 3 minutes but other suitable combinations of temperature and time may be used.

**3.2 Dry heat sterilisation:** This process of thermal sterilisation is suitable for heat-stable, non-aqueous products and powders. The reference conditions are a minimum of 160° for at least 2 hours; other combinations of time and temperature may be used provided that it has been satisfactorily demonstrated that the process chosen delivers an adequate level of lethality when operated routinely within the

established tolerances. The procedures and precautions employed should be such as to give an SAL of 10<sup>-6</sup> or better.

The process of sterilisation is carried out by a batch process in an oven specially designed for that purpose. The oven is supplied with heated, filtered air, distributed uniformly throughout the chamber by convection or radiation employing a blower system with devices for sensing, monitoring, and controlling the critical parameters. The steriliser is loaded in such a way that a uniform temperature is achieved throughout the load. The temperature-sensing elements are inserted into representative containers together with additional elements at the previously established coolest part of the loaded steriliser. An acceptable range in temperature in the empty chamber is ± 15° when the unit is operating at not less than 250°. Where the unit is employed for sterilising components such as containers intended for intravenous solutions, care should be taken to avoid accumulation of particulate matter in the chamber.

An SAL of 10<sup>-12</sup> is considered achievable for heat-stable articles or components.

**3.3 Gas sterilisation:** This method of sterilisation is only to be used when the material to be sterilised cannot withstand the high temperatures obtained in the steam sterilisation or dry heat sterilisation processes. The active agent generally used is ethylene oxide of acceptable sterilising quality. The sterilisation process is generally carried out in a pressurised chamber designed similarly to a steam autoclave but with additional features, particularly for ensuring the reduction of gas or its transformation products in the sterilized product to below the concentration that could give rise to toxic effects during the use of the product.

The programme for the validation of the sterilising process is more comprehensive than for the other sterilisation procedures, since in addition to temperature, the humidity, vacuum/positive pressure, and ethylene oxide concentration also require rigid control. It is important to demonstrate that all critical process parameters in the chamber are adequate during the entire cycle. Since the sterilisation parameters applied to the articles to be sterilised are critical variables, it is advisable to precondition the load to achieve the required moisture content, to minimise the time of holding at the required temperature, prior to placement of the load in the ethylene oxide chamber. The validation is generally done using the product inoculated with appropriate biological indicators.

Wherever possible, the gas concentration, relative humidity, temperature and duration of the process are measured and recorded. Measurements are made where sterilisation conditions are least likely to be achieved, as determined at validation. The effectiveness of the process applied to each sterilisation load is checked using a suitable biological indicator.



One of the principal limitations of the gas sterilisation process is the limited ability of the gas to diffuse to the innermost product areas that require sterilisation. Package design and chamber loading patterns must therefore be determined so that there is minimum resistance to gas diffusion.

**3.4 Ionising radiation sterilisation:** Sterilisation by this method is achieved by exposure of the product to ionising radiation in the form of gamma radiation from a suitable radioisotopic source (such as cobalt 60 or cesium 137) or of a beam of electrons energised by a suitable electron accelerator.

The advantages of the method include low chemical reactivity, low measurable residues, and the fact that there are fewer variables to control. The unique feature of the method is that the basis of control is essentially that of the absorbed radiation dose, which can be precisely measured. Irradiation causes only a minimal rise of temperature, but can affect certain grades of plastics and glass.

The two types of ionising radiation in use are radioisotope decay (gamma radiation) and electron-beam radiation. In either case, the radiation dose to yield the required degree of sterility assurance should be established such that within the range of minimum and maximum doses set, the properties of the article being sterilised are acceptable.

For gamma radiation, the validation of a procedure should include the establishment of article materials compatibility, establishment of product loading pattern and completion of dose mapping in the sterilisation container, establishment of timer setting, and demonstration of the delivery of the required sterilisation dose. For electron-beam irradiation, in addition, the on-line control of voltage, current, conveyor speed, and electron beam scan dimension must be validated.

For gamma radiation the reference absorbed dose is 25 kGy (2.5 megarads). Other doses may be used provided that it has been satisfactorily demonstrated that the dose chosen delivers an adequate and reproducible level of lethality when the process is operated routinely within the established tolerances. The procedures and precautions employed should be such as to give an SAL of  $10^{-6}$  or better. In order to validate the efficacy, particularly of the lower exposure levels, it is necessary to determine the magnitude of the natural radiation resistance of the microbial population of the product. Specific product loading patterns must be established and absorbed minimum and maximum dosage distribution must be determined by the use of chemical dosimeters. These dosimeters should be calibrated against a standard source at a reference radiation plant.

The setting of the preferred absorbed dose should be carried out using a suitable biological indicator.

**3.5 Filtration:** Certain active ingredients and products that cannot be terminally sterilised may be subjected to filtration through microbial retentive materials. The suitability of filters

of such materials should have been demonstrated by means of a microbial challenge test using a suitable test micro-organism. A suspension of *Pseudomonas diminuta* (ATCC 19146, NCIMB 11091) may be suitable. It is recommended that a challenge of at least  $10^7$  CFU per  $\text{cm}^2$  of active filter surface is used and that the suspension is prepared in *tryptone soya broth* which, after passage through the filter, is collected aseptically and incubated aerobically at  $32^\circ$ . Such filter membranes are nominally rated 0.22  $\mu\text{m}$  or 0.2  $\mu\text{m}$ .

It must be ascertained whether the filtration parameters employed in manufacturing the product will significantly influence microbial retention efficiency. Some of the other factors in validation of the filtration process include product compatibility, absorption of drug, preservative and/or other additives, release of contaminants from the filter and initial effluent endotoxin content.

Since the effectiveness of the filtration process is also influenced by the microbial burden of the solution to be filtered, the determination of the microbiological quality of solutions prior to filtration is also an important aspect of validation of the process in addition to other parameters such as pressures, flow rates, and filter unit characteristics. The production process and environment should be designed to minimise microbial contamination and should be regularly subjected to appropriate monitoring procedures. The equipment, containers, and closures and, where possible, the ingredients should be subjected to an appropriate sterilisation process. It is recommended that the filtration process is carried out as close as possible to the filling point. Attention should be given to the filter capacity, batch size and duration of filtration. The filter should not be used for a longer period than has been approved by validation of the combination of the filter and the product in question. The operations following filtration should be carried out under aseptic conditions.

The integrity of an assembled sterilising filter should be verified before use and confirmed after use by carrying out tests appropriate to the type of filter used and the stage of testing, e.g., bubble-point, pressure hold or diffusion rate tests.

Due to the potential additional risks of the filtration method as compared with other sterilisation processes, a prefiltration through a bacteria-retentive filter (e.g. 0.45  $\mu\text{m}$  pore size) may be necessary in cases where a low bioburden cannot be ensured by other means.

## 5.4. Residual Solvents

Residual solvents are defined as organic volatile impurities that may remain in active pharmaceutical substances, excipients, or medicinal products after processing. During the manufacturing processes, the solvents are not completely removed. The solvents may be used to improve the yield in the synthesis of active pharmaceutical substances besides

imparting characteristics of crystal form, purity and solubility. The use of solvents may, therefore, have a critical role in the synthetic process. Nevertheless, testing should be done for residual solvents when production or purification processes are known to result in the presence of such solvents. It is only necessary to test for solvents that are used or produced in the manufacture or purification of active substances, excipients or dosage forms.

Residual solvents do not have any therapeutic effect. Therefore, efforts should be made to remove them to the extent possible to meet the specifications prescribed. Tests for residual solvents are not generally mentioned in specific monographs since the solvents employed may vary from one manufacturer to another and the requirements of this general chapter are applied by adopting the Good Manufacturing Practices and/or other quality based requirements. Normally, the competent authority is to be informed of the solvents employed during the production process. Pharmaceutical products should contain no higher levels of residual solvents than can be supported by safety data.

Depending upon the safety data and their risk to the human health, these solvents are classified as follows:

*Class 1 solvents* — These solvents are known to cause unacceptable toxicities and should be avoided in the manufacture of active pharmaceutical substances, excipients and medicinal products. However, if their use is unavoidable, the restricted concentration limits shown in Table 1 should be applied.

Table 1

Solvent	Concentration Limit (ppm)
Benzene	2
Carbon Tetrachloride	4
1,2, Dichloroethane	5
1,1-Dichloroethene	8
1,1,1 Trichloroethane	1500

*Class 2 solvents* - These solvents are associated with less severe toxicity but should be limited in pharmaceutical products for the protection of consumers from potential adverse effects. Concentration limits shown in Table 2 are applicable if any solvent of this class is used.

Table 2

Solvent	Concentration Limit (ppm)
Acetonitrile	410
Chlorobenzene	360
Chloroform	60
Cyclohexane	3880

1,2-Dichloroethene	1870
Dichloromethane	600
1,2-Dimethoxyethane	100
<i>N,N</i> -Dimethylacetamide	1090
<i>N,N</i> -Dimethylformamide	880
1,4-Dioxane	380
2-Ethoxyethanol**	160
Ethyleneglycol**	620
Formamide**	220
Hexane	290
Methanol	3000
2-Methoxyethanol**	50
Ethylbutylketone	50
Methylcyclohexane	1180
<i>N</i> -Methylpyrrolidone**	4840
Nitromethane	50
Pyridine	200
Sulpholane**	160
Tetralin	100
Toluene	890
1,1,2-Trichloroethene	80
Xylene*	2170

\* Usually 60 per cent *m*-xylene, 14 per cent *p*-xylene, 9 per cent, *o*-xylene with 17 per cent ethyl benzene.

\*\* Not readily detected by head-space injection gas chromatography. Other appropriate procedures should be used for control purposes.

*Class 3 solvents* — These solvents are less toxic and of lower risk to human health. Nevertheless, they need to be limited by good manufacturing practices or other quality-based requirements. The concentration limits of 5000 ppm would be acceptable for the solvents listed in Table 3.

Table 3

Acetic Acid	Heptane
Acetone	Isobutyl acetate
Anisole	Isopropyl acetate
1-Butanol	Methyl acetate
2-Butanol	3-Methyl-1-butanol
Butyl Acetate	Methylethylketone
<i>tert</i> -Butylmethyl Ether	Methylisobutylketone
Cumene	2-Methyl-1-propanol
Dimethyl Sulphoxide (DMSO)	Pentane
Ethanol	1-Pentanol
Ethyl acetate	1-Propanol
Ethyl ether	2-Propanol
Ethyl formate	Propyl acetate
Formic acid	Tetrahydrofuran

### Test procedures

Chromatographic techniques like gas chromatography are generally suitable for determining levels of residual solvents. A non-specific method like Loss on drying may be used if only Class 3 solvents are present. However, if for a Class 3 solvent a justified limit higher than 0.5 per cent is applied, a specific determination of the solvent is required. The test methods described in this general method may be used:

- to identify the majority of the residual solvents of Class 1 and Class 2 in an active pharmaceutical substance, excipient or medicinal product when the residual solvents are unknown;
- as a limit test for Class 1 and Class 2 solvents when present in an active pharmaceutical substance, excipient or medicinal product;
- to quantify Class 2 solvents (with limits greater than 1000 ppm) and Class 3 solvents when required.

Three diluents for sample preparation and two sets of chromatographic conditions are described for examination by gas chromatography.

### Procedure

#### Solutions

**Sample solution (1)** — For water-soluble substances. Dissolve 0.200 g of the substance under examination in *water* and dilute to 20.0 ml with the same solvent.

**Sample solution (2)** — For water-insoluble substances. Dissolve 0.200 g of the substance under examination in *N,N-dimethylformamide* and dilute to 20.0 ml with the same solvent.

**Sample solution (3)** — For substances known or suspected to contain *N,N* dimethylacetamide and/or *N,N*-dimethylformamide. Dissolve 0.200 g of the substance under examination in *3-dimethyl-2-imidazolidine* and dilute to 20.0 ml with the same solvent.

**NOTE** — Where none of the above sample preparation procedures are appropriate, the diluent to be used and the chromatographic conditions to be used must be validated.

**Solvent solution (a)** — To 1.0 ml of *Class 1 residual solvent mixture*, add 9 ml of *dimethyl sulphoxide* and dilute to 100.0 ml with *water*. Dilute 1.0 ml of this solution to 100.0 ml with *water*. Dilute 1.0 ml of the resulting solution to 10.0 ml with *water*.

**Solvent solution (b)** — Dissolve appropriate quantities of the Class 2 residual solvents in *dimethyl sulphoxide* and dilute to 100.0 ml with *water*. Dilute to give a concentration of 1/20 of the limits stated in Table 2.

**Solvent solution (c)** — Dissolve 1.0 g of the solvent or solvents present in the substance under examination in

*dimethyl sulphoxide* or *water*, if appropriate, and dilute to 100.0 ml with *water*. Dilute to give a concentration of 1/20 of the limits stated in Table 1 or 2.

**Blank solution** — Prepare as described for solvent solution (c) but without the addition of solvent(s) (for verifying the absence of interfering peaks).

**Test solution** — Introduce 5.0 ml of the sample solution and 1.0 ml of the blank solution into an injection vial.

**Reference solution (a) (Class 1)** — Introduce 1.0 ml of solvent solution (a) and 5.0 ml of the appropriate diluent into an injection vial.

**Reference solution (a1) (Class 1)** — Introduce 5.0 ml of the sample solution and 1.0 ml of solvent solution (a) into an injection vial.

**Reference solution (b) (Class 2)** — Introduce 1.0 ml of solvent solution (b) and 5.0 ml of the appropriate diluent into an injection vial.

**Reference solution (c)** — Introduce 5.0 ml of the sample solution and 1.0 ml of solvent solution (c) into an injection vial.

**Reference solution (d)** — Introduce 1.0 ml of the blank solution and 5.0 ml of the appropriate diluent into an injection vial.

Close the vials with a light rubber membrane stopper coated with polytetrafluoroethylene and secure with aluminium crimped caps. Shake to obtain homogeneous solutions.

#### Method

Determine by gas chromatography with static head-space injection (2.4.13).

Injection conditions:

Operating parameters	Sample solution No		
	(1)	(2)	(3)
Equilibration temperature (°)	80	105	80
Equilibration time (minutes)	60	45	45
Transfer-line temperature (°)	85	110	105
Pressurisation time (seconds)	30	30	30
Injection volume (ml)	1	1	1

Chromatographic system

- a fused-silica capillary column 30 m x 0.32 mm or 0.53 mm, coated with cross-linked 6 per cent polycyanopropylphenylsiloxane and 94 per cent polydimethylsiloxane (film thickness: 1.8 µm or 3 µm),
- temperature: column 40° for 20 minutes, then raised to 240° at a rate of 10° per minute and maintained at 240° for 20 minutes,
- inlet port at 140° and detector at 250°,

- carrier gas: *Nitrogen for chromatography* at an appropriate pressure flow,
- a flame-ionisation detector (or a mass spectrometer or an electron-capture detector for the chlorinated solvents of Class 1).

If there is interference from the matrix, use the following system:

#### Chromatographic system 2

- a fused-silica capillary column 30 m x 0.32 mm or 0.53 mm, coated with macrogol 20000 (film thickness: 0.25  $\mu\text{m}$ ),
- temperature: column 50° for 20 minutes, then raised to 165° at a rate of 6° per minute and maintained at 165° for 20 minutes,
- inlet port at 140° and detector at 250°,
- carrier gas: *Nitrogen for chromatography* at an appropriate pressure flow,
- a flame-ionisation detector (or a mass spectrometer or an electron-capture detector for the chlorinated solvents of Class 1).

Inject 1 ml of the gaseous phase of reference solution (a) into the column of system 1 and record the chromatogram under such conditions that the signal-to-noise ratio for 1,1,1-trichloroethane can be measured. The signal-to-noise ratio must be at least 5. A typical chromatogram is shown in Fig. 5.4-1.

Inject 1 ml of the gaseous phase of reference solution (a1) into the column of system 1. The peaks due to the Class 1 residual solvents are still detectable.

Inject 1 ml of the gaseous phase of reference solution (b) into the column of system 1 and record the chromatogram under such conditions that the resolution between acetonitrile and methylene chloride can be determined. The system is suitable if the chromatogram obtained resembles the chromatogram shown in Fig. 5-4-2 and the resolution between acetonitrile and methylene chloride is at least 1.0.

Inject 1 ml of the gaseous phase of the test solution into the column of system 1. If in the chromatogram obtained there is no peak which corresponds to one of the residual solvent peaks in the chromatograms obtained with reference solution (a) or (b), then the substance under examination meets the requirements of the test. If any peak in the chromatogram obtained with the test solution corresponds to any of the residual solvent peaks obtained with reference solution (a) or (b) then system 2 is to be used.

Inject 1 ml of the gaseous phase of reference solution (a) into the column of system 2 and record the chromatogram under such conditions that the signal-to-noise ratio for benzene can be measured. The signal-to-noise ratio is shown in Fig. 5.4-3.

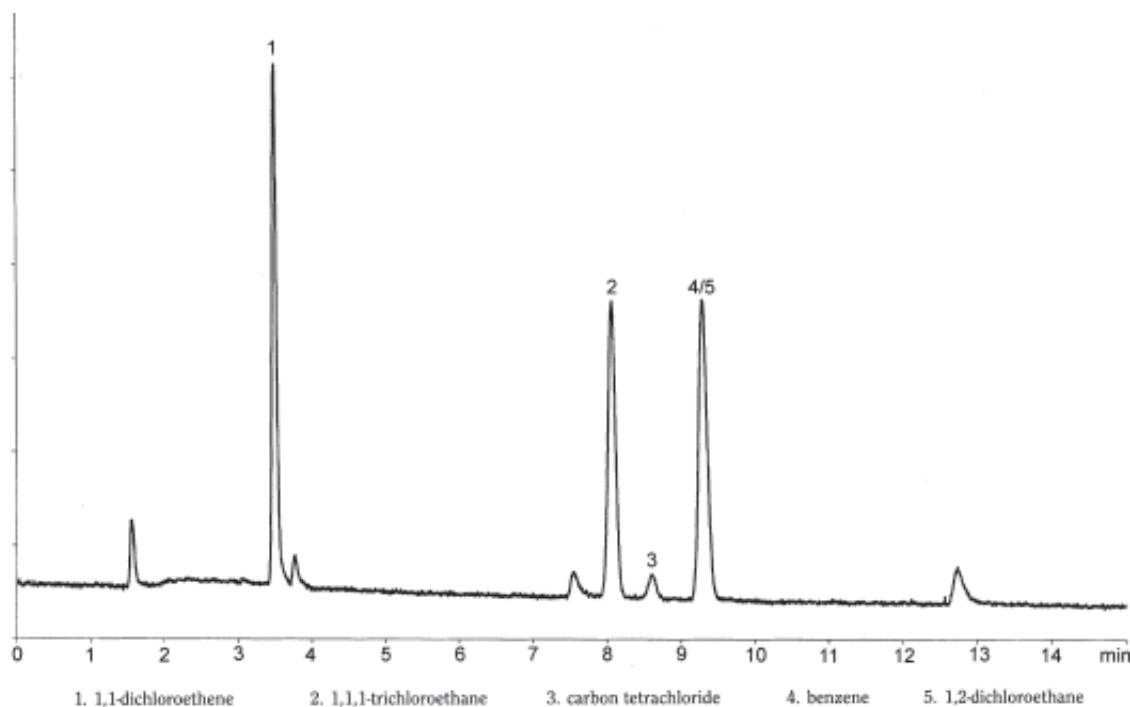

Fig.5.4-1



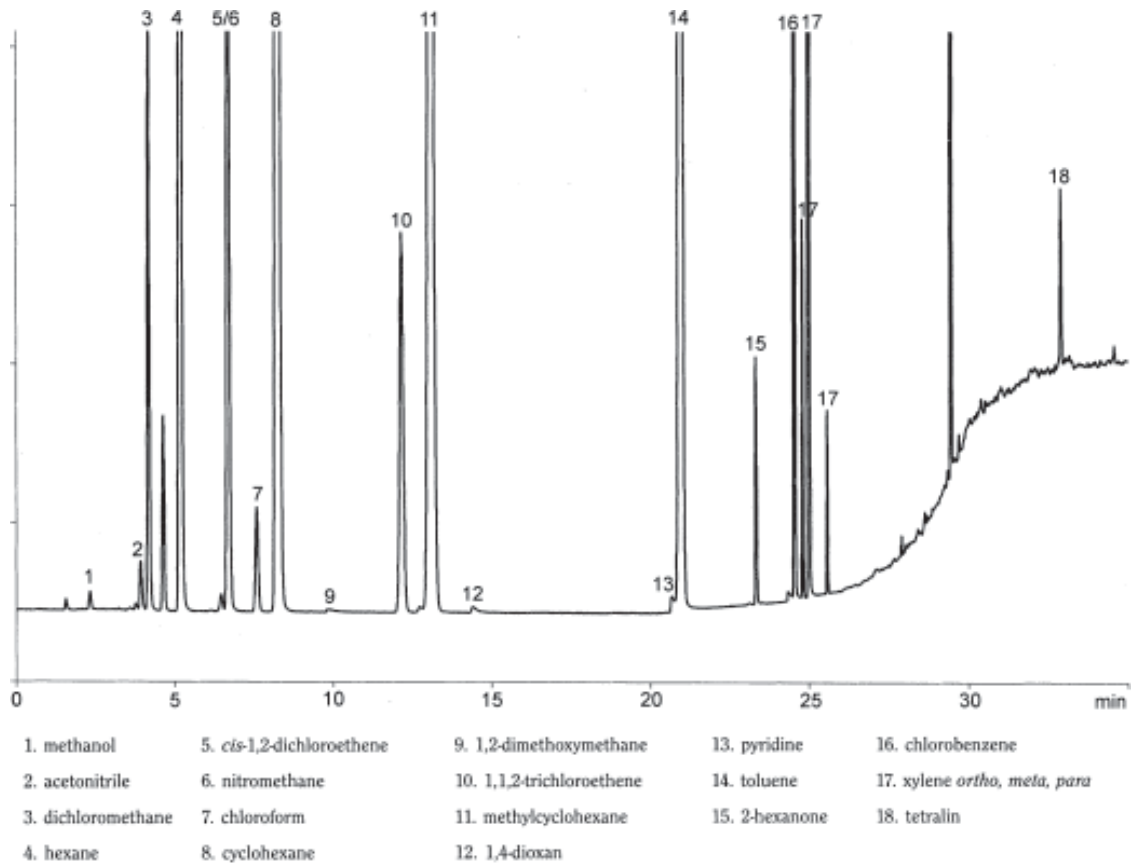

Fig.5.4-2

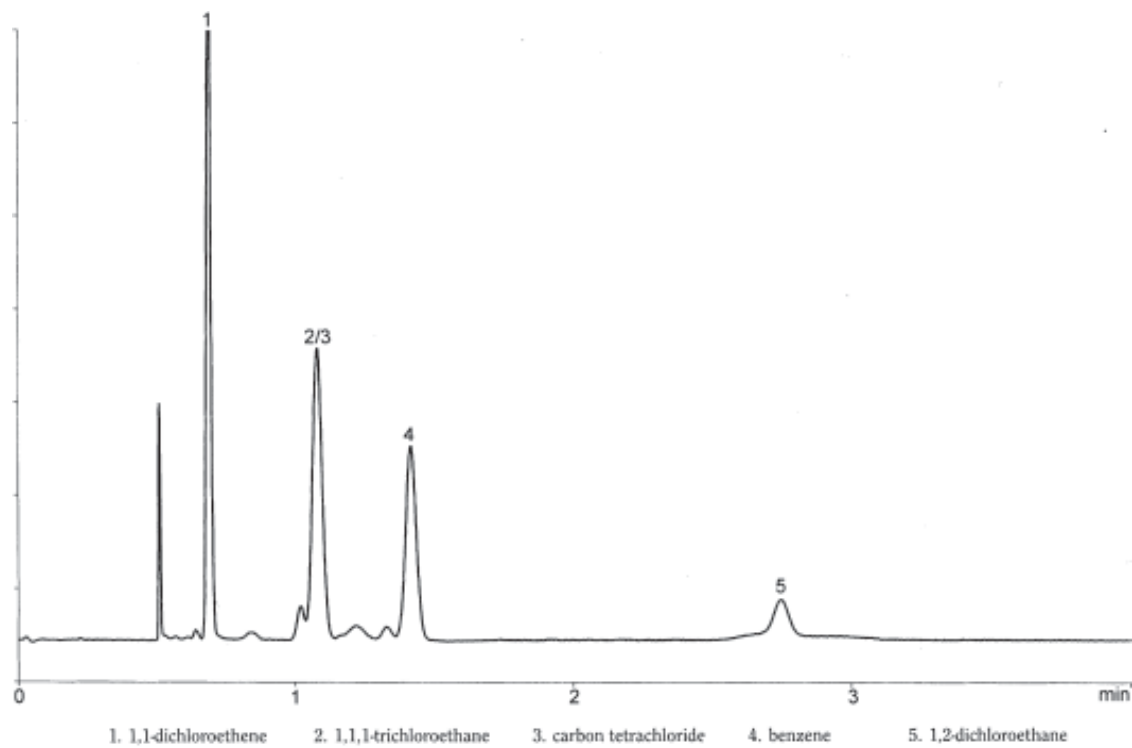

Fig. 5.4-3

Inject 1 ml of the gaseous phase of reference solution (a1) into the column of system 2. The peaks due to Class 1 residual solvents are still detectable.

Inject 1 ml of the gaseous phase of reference solution (b) into the column of system 2 and record the chromatogram under such conditions that the resolution between acetonitrile and trichloroethene can be determined. The system is suitable if the chromatogram obtained resembles the chromatogram shown in Fig. 5.4-4 and the resolution between acetonitrile and trichloroethene is at least 1.0

Inject 1 ml of the gaseous phase of reference solution (a1) into the column of system 2. The peaks due to Class 1 residual solvents are still detectable.

Inject 1 ml of the gaseous phase of reference solution (b) into the column of system 2 and record the chromatogram under such conditions that the resolution between acetonitrile and trichloroethene can be determined. The system is suitable if the chromatogram obtained resembles the chromatogram shown in Fig. 4 and the resolution between acetonitrile and trichloroethene is at least 1.0

Inject 1 ml of the gaseous phase of the test solution into the column of system 2. If in the chromatogram obtained, there is

no peak which corresponds to any of the residual solvent peaks in the chromatogram obtained with reference solution (a) or (b), then the substance under examination meets the requirements of the test. If any peak in the chromatogram obtained with the test solution corresponds to any of the residual solvent peaks obtained with reference solution (a) or (b) and confirms the correspondence obtained when using system 1, then proceed as follows.

Inject 1 ml of the gaseous phase of reference solution (c) into the column of system 1 or system 2. If necessary, adjust the sensitivity of the system so that the height of the peak corresponding to the identified residual solvent(s) is at least 50 per cent of the full scale of the recorder.

Inject 1 ml of the gaseous phase of reference solution (d) into the column. No interfering peaks should be observed.

Inject 1 ml of the gaseous phase of the test solution and 1 ml of the gaseous phase of reference solution (c) into the column. Repeat these injections twice more.

The mean area of the peak of the residual solvent(s) in the chromatograms obtained with the test solution is not greater than half the mean area of the peak of the corresponding residual solvent(s) in the chromatograms obtained with

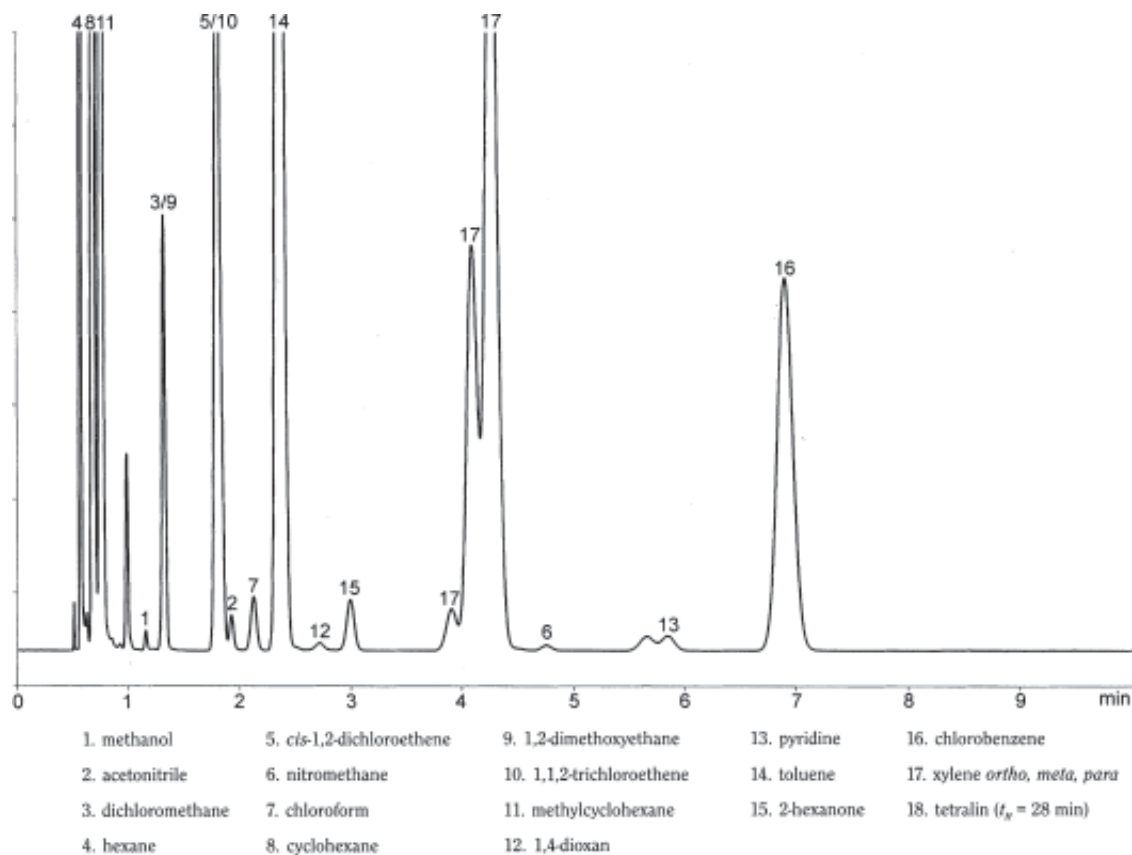

Fig. 5.4-4

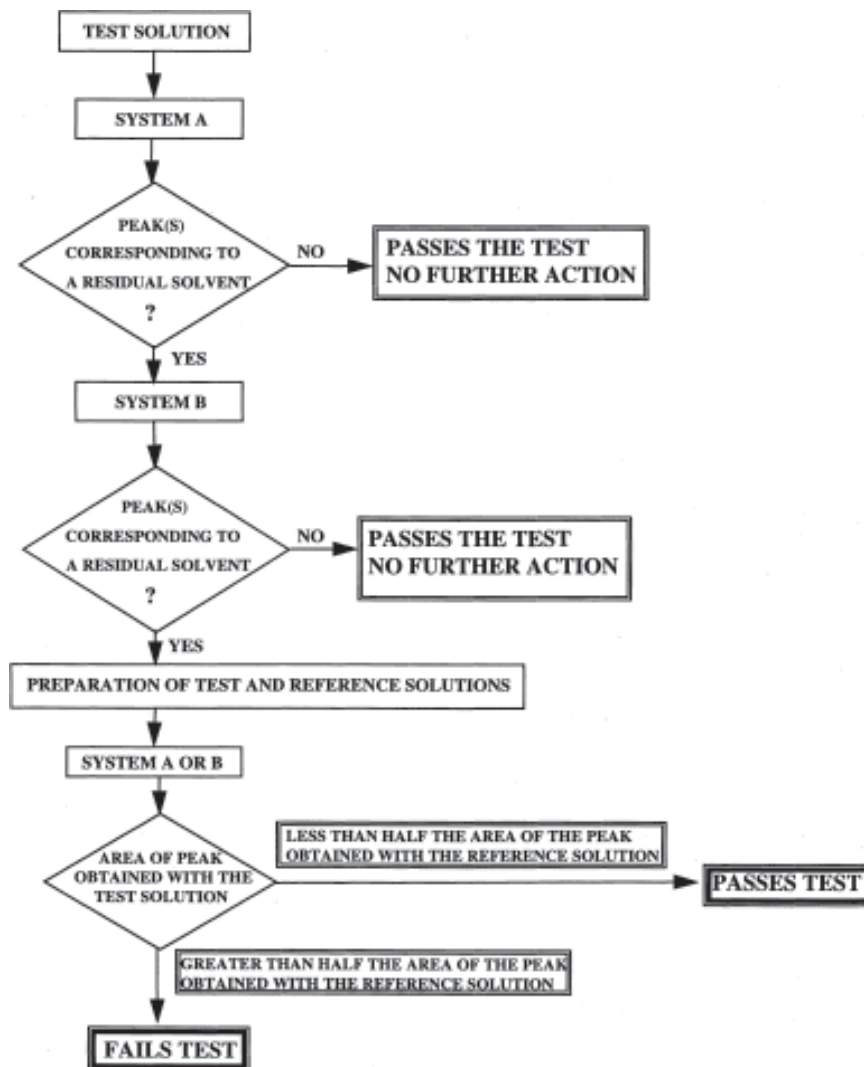

Fig. 5.4-5

reference solution (c). The test is not valid unless the relative standard deviation of the differences in areas between the analyte peaks obtained from three replicate paired injections of reference solution (c) and the test solution, is at most 15 per cent.

When a residual solvent of Class 2 or Class 3 is present at a level of 0.1 per cent or less, then the content may be quantitatively determined by the method of standard additions.

The entire procedure is shown in the Fig. 5.4-5 flow diagram.

## 5.5. Impurities

This chapter provides guidance on the control of impurities in drug substances and formulated preparations. It applies mainly to totally synthetic organic medicinal substances and those

substances obtained by synthetic modification of a naturally-produced precursor, it is not necessarily relevant to other organic substances e.g. those of plant or animal origin, biological and biotechnological products, inorganic substances and pharmaceutical excipients. It provides an approach to the setting of limits for impurities in articles for which the individual monographs do not provide either a test or specific limits.

An impurity is defined as any component of a drug substance for pharmaceutical use or of a drug product that is not the chemical entity that defines the substance, or in the case of a drug product, not an excipient in the product. It includes among other things, degradation products of the drug substance that may develop on storage and in the case of dosage forms, those that may also be formed during manufacture and storage.

The monographs of the Pharmacopoeia have been designed to ensure the minimum acceptable quality of drug substances and drug products for users. Tests for related substances have also been provided in many monographs to limit impurities and degradation products. Although one of the primary objectives of the Pharmacopoeia is to guarantee the identity, strength, purity and quality of official articles, it is not possible to include in each monograph a test for every impurity or contaminant or even an adulterant that might be present. The exclusion of a limit for impurities in a monograph does not absolve the manufacturer of providing assurance to the user on the safety of a drug. It is incumbent on the manufacturer to follow Good Manufacturing Practices (GMP) and to ensure the limitation of impurities based on knowledge of the properties of the chemical entity and the likelihood of related substances being associated with the end product during production and subsequent storage.

Material found to contain an impurity not detectable by the prescribed tests of a monograph may be deemed to be not of pharmacopoeial quality particularly if the nature of the impurity(ies) found is not compatible with GMP.

In general, the tests in a monograph are tests for purity that provide information on the extent of known potential or actual impurities rather than for guaranteeing freedom from all possible impurities. Chemical tests that reveal the levels of particular impurities or classes of impurities are often augmented by physical tests such as specific optical rotation, light absorbance, refractive index etc. Besides, non-specific tests such as sulphated ash, heavy metals, loss on drying etc. contribute to the assurance of the general quality of the article and of the use of GMP in its production, the avoidance of contamination and the removal of volatile solvents. Notwithstanding this situation, there is a need to limit impurities that may arise from various sources in the course of manufacture.

### **Impurities in Drug substances**

Impurities fall into one or more of the following categories:

- Inorganic impurities
- Organic impurities
- Residual solvents

Inorganic impurities usually result from the manufacturing processes and include catalysts, ligands, reagents, heavy and other metals and inorganic salts. Impurities associated with input raw materials and storage conditions can also contribute to the impurity profile of the drug substance. The detection and quantification of such impurities by classical physico-chemical methods should not present any problems.

Organic impurities may be drug-related or process-related and consist of identified, specified impurities, unidentified, specified impurities or total unknown impurities.

In designing the specifications for any drug substance a manufacturer should determine the actual and potential impurities most likely to arise during the synthesis, purification and storage, on the basis of scientific knowledge of the chemical reactions involved in the synthesis. Impurities arising out of the manufacturing process and /or storage of the drug substance include starting materials, intermediates, by-products and degradation products. Irrespective of the nature of these impurities, limits and acceptance criteria have to be worked out on the basis of factors such as toxicity, process capability, manufacturing practices and so on.

The test for Related substances given in many monographs covers manufacturing impurities (intermediates and by-products) and/or degradation products.

Specific tests may be supplemented by a more general test controlling other impurities.

Solvents are inorganic or organic liquids used as vehicles for the preparation of solutions or suspensions during the synthesis of a drug substance. Since these are generally of known toxicity, they can be controlled with appropriate limits as listed in chapter 5.4 (Residual solvents). In addition to a general limit on solvents remaining behind in the final drug substances, some drugs need specific limits for specific solvents where variation in levels requires control.

### **Impurities in Drug products**

In general, drug products have a test for impurities adapted from that in the monograph for the active ingredient with necessary modifications for including degradation products. Degradation products include a) degradation products of the active ingredient in the drug product, b) reaction products of the active ingredient with the excipient(s), c) reaction products of the active ingredient with the immediate container/closure system and d) products of interaction between the various drugs in a combination product. Both identified and unidentified degradation products are included in the acceptance criteria. Identification of such impurities is done from stability studies, forced degradation studies and analyses of routine production batches.

Wider limits and/or additional controls may be required for impurities arising during manufacture or on storage of the dosage form.

### **Test methods**

Meaningful limitation of impurities is possible only with validated analytical methods that can help in determining the limits of detection and quantitation. With drug products the methods should be validated to demonstrate that the drug product components and impurities unique to the drug substance and excipients do not interfere with or are separated from specified and unspecified degradation products in the final product.



The most widely used methodology is chromatography which is the basis of the test for Related substances. The test may be specific or general. A specific test is one where a particular impurity arising from the manufacturing process or from degradation needs to be limited on grounds of toxicity or any other special reason. Where the impurity is known to be particularly toxic, this should be taken into account. Such specific tests include a chromatographic or colorimetric comparison with a sample of the named substance e.g. salicylic acid in aspirin. Both types of tests require the use of Reference Substances. In chromatographic determinations, in the absence of a reference substance it is usual practice to limit the levels of impurities by the simple test of comparison of the unknown spot or peak with a spot or peak obtained with a dilute solution of the substance under examination.

Thin-layer chromatography (TLC) is quick and is particularly useful in process monitoring and in detecting impurities during the course of manufacture. However, it has its limitations in fixing limits for specific impurities in the final product although for long it was the most widely used for this purpose.

Total impurities can be determined by gas chromatographic and liquid chromatographic tests, where the total impurity levels can be obtained by summation of the peak areas (usually in the range 1 to 2 per cent). Here again, this procedure is rarely adopted in TLC tests because of the semi-quantitative nature of estimating individual spots and the imprecise nature of expressing results for the total impurities. This drawback can be overcome to an extent by the use of two- and three-level tests. In the former, in addition to a nominal concentration of the reference solution, another at a lower concentration is used for spotting the plate; in the latter, two more solutions at different lower concentrations are used.

In liquid chromatographic tests the relative detector response factor that expresses the sensitivity of a detector relative to a standard substance is an important factor to be considered. As a general thumb rule, if the response factor of an impurity is between 0.08 and 1.2, it may be considered the impurity has a similar response to that of the drug substance. Also, response factors less than 0.2 or more than 5 are not recommended. In such cases, the method needs to be amended to bring the response factor within the acceptable range by either choosing a different wavelength of measurement or a different method of visualisation.

Unknown impurities may be limited by reference to a dilution of the substance under examination used as a reference solution.

#### Acceptance criteria for Impurities

Acceptance criteria should be set taking into account the qualification (the acquisition and evaluation of data establishing the safety of an impurity) of the degradation

products, accelerated and long-term stability data, the expected expiry period and the recommended storage conditions for the drug product. Allowance should be made for the normal variations in manufacturing, analysis and the stability profile.

It is recommended that the specifications for a drug substance should include, where applicable, acceptance criteria for

- each identified specified impurity
- each unidentified impurity
- total impurities
- residual solvents
- inorganic impurities

The specifications for a drug product should include, where applicable, acceptance criteria for

- each specified degradation product
- any unspecified degradation product
- total degradation products

Where for any reason, data on qualification and quantification of impurities is not available, a workable criterion for acceptance could be:

*For drug substances:*

- each identified specified impurity: not more than 0.5 per cent,
- each unidentified impurity: not more than 0.3 per cent,
- total impurities: not more than 1.0 per cent,

provided it has been determined that the impurities are not toxic. Higher limits may be set if scientifically justified.

*For drug products:*

- each identified specific degradation product: not more than 1.0 per cent,
- each unidentified degradation product: not more than 0.5 per cent,
- total degradation products: not more than 2.0 per cent,

provided it has been determined that the impurities are not toxic. Higher limits may be set if scientifically justified.

In any case, the specifications should in course of time be refined to include tighter and more specific limits in the light of experience with production batches and a better understanding of the manufacturing process.

## 5.6. Water for Pharmaceutical use

Water is one of most widely and abundantly used substances in pharmaceutical manufacturing. It is required for a variety of purposes ranging from manufacturing processes to the preparation of the final dosage forms. The quality of water therefore assumes considerable importance.

This chapter is not exhaustive in scope; it contains points that are basic information to be considered, when appropriate, for the processing, holding and use of water.

The control of the chemical and microbiological quality of water for pharmaceutical use is governed by many factors of which the most important is the variability of the basis source viz. municipal water or any other water. The starting material for most forms of water is drinking water which should normally be subject to municipal or any other local regulations or is drawn from a private well or reservoir. Water prepared from other starting material may have to be processed to meet drinking water standards. Drinking water itself may be used in the manufacture of drug substances but not in the preparation of dosage forms, or in the preparation of reagents and test solutions.

There are many different grades of water for pharmaceutical purposes. Broadly, there are two types of water: bulk waters, typically produced on site and packaged waters which are produced, packaged, and sterilised to preserve microbial quality throughout their shelf life.

Given below is a brief description of the various types of pharmaceutical waters and their significant uses or attributes.

**Purified Water.** This article is used as an excipient in the production of nonparenteral preparations and in other applications such as cleaning of equipment and non-parenteral product-contact components. Unless otherwise specified, it is also to be used for all tests and assays of the Pharmacopoeia.

Purified Water represents water rendered suitable for pharmaceutical use by processes such as distillation, ion-exchange treatment (deionisation or demineralisation), or reverse osmosis. The minimal quality of source or feed water for the production of Purified Water is Drinking Water. The prepared water meets the specifications for chemical purity (see IP monograph) and it contains no added substances. However, the different methods of producing it present different potential for contamination. Purified Water produced by distillation is sterile, provided the production equipment is suitable and sterile. Water obtained by ion-exchange treatment or by reverse osmosis may contain micro-organisms and it will be necessary to monitor the bacterial quality of the water frequently, particularly with the use of the purifying systems following periods of shutdown of more than a few hours.

Purified water systems must be validated to reliably and consistently produce and distribute water of acceptable chemical and microbiological quality. Water systems that are operated under ambient conditions are susceptible to the formation of tenacious biofilms of microorganisms that can be the source of undesirable levels of viable microorganisms or endotoxins in the water produced. These systems need frequent sanitisation and microbiological monitoring.

**Water for Injections.** This article is used as an excipient in the production of parenteral and other preparations where product endotoxin content must be controlled; it is also used in other applications such as cleaning of certain equipment and parenteral product-contact components.

Water for Injections is water that is pre-treated to render it suitable for subsequent treatment and then purified by distillation or by reverse osmosis and it meets all of the chemical requirements stated under Purified Water (see IP monograph). It is not intended to be sterile but should comply with the test for a limit of bacterial endotoxins (2.2.3), or as appropriate, with the test for pyrogens (2.2.8). It must be produced, stored and distributed under conditions designed to prevent production of endotoxins or pyrogens.

The equipment and procedures used by the system to purify, store and distribute Water for Injections must be designed to minimise or prevent microbial contamination and also remove incoming endotoxin from the starting water.

Water for Injections systems must be validated to reliably and consistently produce and distribute this quality of water.

**Pure Steam.** This article is intended for use in steam-sterilising porous loads and equipment and in other processes such as cleaning where condensate would directly contact the pharmacopoeial articles and containers for these articles process surfaces that would in turn contact these articles or materials that are used in testing such articles.

Pure Steam is prepared from suitably pretreated source water, similar to the pre-treatment used for Purified Water or Water for Injections, vaporised with a suitable mist elimination, and distribution under pressure. Sources of contamination during the preparation are entrained water droplets, anti-corrosion steam additives, or particulate matter from the production and distribution system.

**Sterile Water for Injections.** This article is Water for Injections which is sterilised within 12 hours of collection and distributed in sterile containers. It is intended mainly for use as a solvent for parenteral preparations such as powders for injection that are distributed dry because of limited stability of their solutions. It should be packaged only in single dose containers of not larger than 1-litre size.

#### **Water for Analytical Purposes**

**Distilled Water.** This article is produced by vaporising water and condensing it in a purer state. It is mainly used for preparing reagents but may also be required for other laboratory operations such as rinsing an analyte, transferring a test material as a slurry, as a calibration standard or analytical blank and for cleaning of apparatus. Unless specifically indicated, water meeting the requirements for Purified Water derived by other means of purification could be equally suitable where the use of distilled water is recommended.

**Freshly Distilled Water.** Also known as “recently distilled water”, it is the article produced in a similar manner as Distilled Water but is to be used shortly after its generation. This implies the need to avoid endotoxin contamination, or any other adventitious forms of contamination from the air or containers that could arise with prolonged storage. It is used for preparing solutions for subcutaneous test animal injections and also for preparing specific reagent solutions.

**Deionised Water.** This article is produced by an ion-exchange process in which contaminating ions are replaced with either  $H^+$  or  $OH^-$  ions. It is used primarily as a solvent for preparing reagents and for the other aforementioned laboratory operations where distilled water is used. In this case too, Purified Water derived by other means of purification could be equally suitable where Deionised Water is specified.

**High Purity Water.** This article is water that is prepared by distilling previously deionised water, and then filtering it through a 0.45- $\mu m$  membrane. This water should have an on-line conductivity of not more than 0.15  $\mu S/cm$  at 25°. It may be used where the use of ammonia-free water is specified.

**Carbon Dioxide-free Water.** This is Purified Water that has been vigorously boiled for at least 5 minutes, then cooled and protected from absorption of atmospheric carbon dioxide. Most of the uses of this grade of water are either associated as a solvent in pH-related or pH-sensitive reagents or determinations. It is also used in certain optical rotation tests and in the tests for appearance of solution. In addition to boiling, deionisation could be an effective process for removing carbon dioxide.

**Water BET.** This is usually Water for Injections which may have been sterilised. It is free from a level of endotoxin that would yield any detectable reaction or interference with the lysate used in the test for Bacterial endotoxins (2.2.3).

#### **Guidelines for Microbial Control in Water for Pharmaceutical Use**

The major exogenous source of microbial contamination of bulk pharmaceutical water is source or feed water. Feed water must at the least meet the quality attributes of Drinking Water for which the levels of coliforms are regulated. A wide variety of other micro-organisms may be present in the incoming water. Additionally, unit operations of the water system, including the distribution network, can be another major source of endogenous microbial contamination. For effective control of the microbial quality of water used in the production and quality control of pharmaceutical waters, a monitoring programme with validated alert and action levels, should be in place. Performance-based alert and action levels should be well below water specifications.

The criteria for controlling the microbial quality of Purified Water and Water for Injections vary according to the method of production, distribution and/or storage and use. The

purification systems used for production of water of acceptable microbiological quality should be validated prior to production for which purpose suitable microbiological, chemical, and operating controls should be evolved.

Tests for microbial testing of water include but are not limited to pour plates, spread plates, membrane filtration, and most probable number (MPN) tests.

A total aerobic microbial count that may be used for source drinking water is 500 colony-forming units (CFU) per ml. Since Purified Water is used in the manufacture of a variety of products, the limit for this article should be based on the intended use of the water, the nature of the product to be made and the effect of the manufacturing process on the microbial population. As a general guideline, a limit of 100 CFU per ml for Purified Water and 10 CFU for Water for Injections may be adopted.

If the aforementioned limits are approached or exceeded, corrective action is called for. The actions to be taken may include sanitisation of the system by for example, flushing with hot water, steam, or suitable disinfecting agents. This should be followed by extensive sampling and testing to ensure that the corrective action has resulted in conformance to desired standards.

## **5.7. Statistical Analysis of Results**

### **5.7.1. Introduction**

Biological assays are prescribed for drug substances and preparations where the potency cannot be adequately determined by chemical or physical means. The principle of such assays is to compare how much of a sample under examination produces the similar biological effect in a given quantity (the Unit) of a standard preparation termed as control sample. It is essential to ensure that the conditions under which the sample and the standard preparation tested are identical in all respects of time, environmental factors and biological parameter used.

An estimate of potency derived from a biological assay is subject to random errors due to inherent variability of biological response. An appropriate statistical design of the biological assay and the subsequent analysis of data will provide unbiased estimation of potency.

Methods for the design of assays and the calculation of their errors are described below. Alternative assay designs or methods of calculation may be used provided that they are as scientifically valid as those described here.

### **5.7.2. Precision of Biological Assays**

On the evidence of biological assays, it is not possible to make a precise statement of the actual limits within which the

potency of a preparation is likely to be. It is the usual convention that if there is a 95 per cent probability that the true potency will be within the limits specified, then this is deemed equivalent to certainty.

The limits are derived from the estimated errors due to random variations in experimental results. However, even the estimation of the error itself may be subject to error, except when there are a very large number of observations. Allowance has to be made for this in setting up the *confidence* or *fiducial limits*, that is, limits within the true potency will be in 95 per cent of the experiments.

It is to be noted that the error may be estimated in two ways, from (a) *an internal estimate* from the actual assay itself or (b) *a direct estimate* from several similar experiments, that is, experiments conducted under identical conditions for all factors within control. From the methods prescribed in the Pharmacopoeia, it will be seen that internal estimates are not always possible. Direct estimates on the other hand take into account any variation from time to time or from experiment to experiment and therefore include all sources of variations. However, direct estimates will be reliable only if a sufficiently large number of assays conducted in identical form or design are available. Moreover, any such direct estimates given in the Pharmacopoeia may not apply to a similar experiment done in a particular laboratory, unless the sources of variation are the same as occurring in the given estimates.

Potency estimates are generally made on the basis of the logarithms of the doses (see Section 5.7.5)

When the terms ‘stated’ potency and ‘estimated’ potency are used in this section and elsewhere, the following definitions are intended.

*Stated potency* — This is a nominal value assigned to a formulation or preparation from knowledge of the potency of the bulk material or, in the case of bulk drugs, it may be a calculated potency.

*Estimated potency* — This is the potency calculated from the data obtained from assays.

**5.7.3. Glossary of Symbols**

<i>Symbol</i>	<i>Definitions</i>
b	estimate of slope of regression line of response on log dose based on all preparations in the assay.
c'	constant used in evaluation of <i>fiducial</i> limits (Table 7)
d	number of dose levels for each preparation in a balanced assay
f	degrees of freedom which is the number of independent observations in a set of data.

h	number of preparation in an assay, including the standard preparation.
k	number of different treatments within an assay (k = dh)
n	number of replicates in each treatment.
n'	number of individual potency estimates
s <sup>2</sup>	estimate of variance given by error mean square in analysis of variance — also used with a letter subscript, e.g. S <sub>M</sub> <sup>2</sup> is variance of log potency M
s	estimate of standard deviation = square root of s <sup>2</sup>
s <sub>1</sub> , s <sub>2</sub>	low and high doses of standard preparation <u>S</u> measured in units of activity or weight.
t	student’s statistic (Table 1)
u <sub>1</sub> ,...,z <sub>3</sub>	doses of test preparation <u>U</u> ..... <u>Z</u> measured as specified in the monographs
w	weighing co-efficient in probit analysis (Table 16)
y	individual response or transformed response.
y'	calculated response to replace as missing value.
$\bar{y}_s, \dots, \bar{y}_z$	mean responses for standard and unknown preparations
A <sub>U</sub>	potency assumed for test preparation <u>U</u> when making up doses.
B <sub>1</sub> ...B <sub>2n</sub>	total response for each subject (1 to 2 n) in twin cross-over assay.
B'	incomplete total response in a block or row containing one missing value.
C	statistic used in calculation of fiducial limits (Equation 17)
D <sub>I</sub> , D <sub>II</sub>	total response on day I or day II in a cross –over assay
E	regression sum of squares (Table 4)
F	ratio of two independent estimates of variance (Table 6)
G'	incomplete total response in an assay , excluding a missing value.
I	interval between adjacent log doses
K	correction term used in analysis of varianc
	$\left[ K = \frac{(\sum y)^2}{N} \right]$
L	fiducial interval in logarithms



$L_s, \dots, L_z$	linear contrasts for standard and unknown preparations (Tables 3 and 4)
M	estimate of log potency — used with a letter subscript in a multiple assay to denote a particular preparation ( $M = \log R$ )
$\bar{M}$	mean of several independent estimates of M
$M'$	log potency ratio or estimate of log potency before correction by assumed potency ( $M' = \log R'$ )
N	total numbers of responses in an assay
$N_s, N_u$	total numbers of responses for preparation <u>S</u> and <u>U</u>
P	probability
R	potency estimate — used with a letter subscript to denote a particular test preparation ( $R = \text{antilog } M$ )
$R'$	estimate of potency or potency ratio before correction by assumed potency ( $R' = \text{antilog } M'$ )
$R_1, \dots, R_n$	total response in each block of a randomized block design  standard preparation
S	total response to a standard preparation
$S_1, S_2$	total responses to low and high doses of standard preparation <u>S</u>
$T'$	incomplete total response to treatment, excluding a missing value
$\underline{U}, \dots, \underline{Z}$	unknown preparations under test
$U, \dots, Z$	total responses to test preparation <u>U</u> , ..., <u>Z</u>
$U_1, U_2$	total responses to low and high doses of unknown preparation <u>U</u>
W	statistical weight used in combination of several independent estimates of log potency.
X	log dose — also used with subscript to indicate a particular preparation, e.g. $X_s$
$\bar{X}$	mean log dose
$X^2$	chi-square statistic

*NOTE* — All logarithms throughout this section are to base 10.

#### 5.7.4. Randomisation

The allocation of individual units (animals, tubes, etc.) to different experimental groups should be made by some strictly random process. Any other choice of experimental conditions,

which is not deliberately allowed for in the experimental design, should also be made randomly. Examples are the choice of positions for cages in a laboratory and the order in which treatments are administered. In particular, a group of animals receiving the same dose of any preparation should not be treated together (at the same time or in the same position) unless there is strong evidence that the relevant source of variation (for example, between times, or between positions) is negligible. Random allocations may be made from computer generated design or from standard tables of random sampling numbers which are usually accompanied by instructions for use.

#### 5.7.5. Estimates of Error from Repeated Assays along with Illustrative Examples

When the same preparation has been assayed a number of times by exactly the same method and with the same number of observations in each assay, or when a number of preparations have been assayed more than once by the same method, the error of a single estimate can be calculated from the differences occurring among the potency estimates. The resulting error is, of course, applicable only to assays of the same type and size as those used in the calculations. This method of calculation has the advantage that it gives a direct estimate which takes all sources of random error into account. It has the disadvantages that it does not give a reliable value for the error unless a large number of results are available, and that its validity depends on the assumptions that the error is normally distributed and remains constant when different populations of animals are used. The estimates given in the Pharmacopoeia for the error of the assays of some of the antitoxins were obtained in this way, i.e. the same preparation was assayed in a number of different laboratories and the error calculated from the results.

For most methods of assay estimates of potency will be obtained on a logarithmic scale. In any case the analysis should be done on the logarithms of the potency estimates ( $M$ ) as these should be normally distributed.

The variability of the different values of  $M$ , from one assay to another is conveniently measured by their standard deviation ( $s_M$ ). This may be obtained by calculating the variance ( $s_M^2$ ) as follows.

... (1)

The second formula being the more suitable for desk calculation. Here  $\bar{M}$  is the mean of the values of  $M$ , and  $n'$  is the number of assays. The standard deviation,  $s_M$ , is then obtained as the square root of  $s_M^2$ .

Variances estimated by Equation 1 are unreliable when only a few assays of the same preparation have been carried out and large experiments, which would give more reliable estimates of variance, are rarely undertaken. Therefore it is generally more satisfactory to estimate a common value for the variance from results for several preparations each of which has been assayed two or more times. A pooled estimate of variance is then calculated as

$$s_M^2 = \frac{\sum_p [M - (\bar{M})^2]}{\sum_p (n' - 1)} = \frac{\sum_p [\sum M^2 - (\sum M)^2 / n']}{\sum_p (n' - 1)} \quad \dots (2)$$

where,  $\sum_p$  denotes summation over the several preparations.

Equation 2 should not be used if there is evidence that variances are substantially different for different preparations.

The precision of a single potency estimate (R) may be expressed in terms of 0.95 fiducial (or confidence) limits, by the formula

$$\text{antilog} (M \pm ts_M) \quad \dots (3)$$

The appropriate value of t may be obtained from Table 1 according to the number of degrees of freedom (f) given by the denominator of Equation 1 or 2.

It is expected that, 95 times out of 100, limits calculated in this way will contain the true potency.

$$\left( \bar{M} \pm ts \frac{\bar{M}}{M} \right)$$

TABLE 1 – Both sided values of t (P=0.95)

Degrees of freedom (f)	Both sided values of t	Degrees of freedom (f)	Both sided values of t
1	12.71	14	2.14
2	4.30	15	2.13
3	3.18	16	2.12
4	2.78	17	2.11
5	2.57	18	2.10
6	2.45	19-20	2.09
7	2.36	21	2.08
8	2.31	22-23	2.07
9	2.26	24-26	2.06
10	2.23	27-29	2.05
11	2.20	30-32	2.04
12	2.18	Infinity	1.96
13	2.16		

The fiducial limits for the potency, expressed as a percentage of the estimated potency, are the antilogarithms of  $(2 \pm ts_M)$ . Example 1 illustrates the calculation for several assays of one

preparation by use of Equation 1. Example 2 illustrates the calculation for more than one preparation by use of Equation 2. When the same preparation has been assayed n time, a single estimate of its activity may be obtained from the antilog of the mean ( $\bar{M}$ ) of the various values of M.

Fiducial limits for the mean potency may be obtained as

$$\text{antilog} \quad \dots (4)$$

$$\text{where, } s_M^2 = \frac{s_M^2}{n'} \quad \dots (5)$$

and  $s_M^2$  is obtained from equation (1) or (2) as appropriate.

Example 1 – Estimate of error from repeated assays.

Potency estimate (R)	log R = M	M <sup>2</sup>
0.738	$\bar{1.8681} = -0.1319$	0.017398
0.766	$\bar{1.8842} = -0.1158$	0.013410
0.803	$\bar{1.9047} = -0.0953$	0.009082
0.817	$\bar{1.9122} = -0.0878$	0.007709
0.870	$\bar{1.9395} = -0.0605$	0.003660
0.889	$\bar{1.9489} = -0.0511$	0.002611
Total	-0.5424	0.053870

The variance of M is, calculated from Equation 1.

$$S_M^2 = \frac{1}{5} \left[ (0.053870) - \frac{(-0.5424)^2}{6} \right] = 0.000967$$

So that  $S_M = 0.0311$

At P=0.95 with 5 degrees of freedom, t = 2.57 (Table 1) or at 95 per cent fiducial levels with 5 degrees of freedom.

Fiducial limits as percentage of potency estimate

$$\begin{aligned} &= \text{antilog} [2 \pm (2.57)(0.0311)] \\ &= \text{antilog } 1.9201 \text{ and antilog } 2.0799 \\ &= 83.2 \text{ per cent to } 120.2 \text{ per cent} \end{aligned}$$

These fiducial limits apply to any single estimate of potency from an individual assay.

Example 2 – Estimate of error from repeated assays with several preparations

Potency estimate (R)	Log R = M	M <sup>2</sup>
Preparation I		
0.792	$\bar{1}.8987 = -0.1013$	0.010262
0.800	$\bar{1}.9031 = -0.0969$	0.009390
0.828	$\bar{1}.9180 = -0.0820$	0.006724
Total	-0.2802	0.026376
Preparation II		
0.852	$\bar{1}.9304 = -0.0696$	0.004844
0.905	$\bar{1}.9566 = -0.0434$	0.001884
Total	-0.1130	0.006728

The variances of M calculated from Equation 2

$$S_M^2 = \frac{1}{3} \left[ \left\{ (0.026376) - \frac{(-0.2802)^2}{3} \right\} + \left\{ (0.006728) - \frac{(-0.1130)^2}{2} \right\} \right]$$

$$= \frac{1}{3} (0.000549) = 0.000183$$

So that  $S_M = 0.0135$

At  $p = 0.05$  with 3 degrees of freedom,  $t = 3.18$  (Table 1) or at 95 per cent fiducial levels with 5 degrees of freedom.

Fiducial limits as percentage of potency estimate

$$= \text{antilog} [2 \pm (3.18)(0.0135)]$$

$$= \text{antilog } 1.9571 \text{ and antilog } 2.0429$$

$$= 90.6 \text{ per cent to } 110.4 \text{ per cent}$$

These confidential limits apply to any single estimate of potency from an individual assay.

### 5.7.6. Direct Assays along with Illustrative Example

In this type of assay, the doses which produce some fixed effect in each animal (e.g. death) are measured. The assay of a digitalis preparation using guinea – pigs is an example (Example 3) of such a test. There are generally two groups of estimates of individual effective doses, one showing the results with a solution of the standard, and the other the results with a solution of the preparation of unknown activity. The solutions are made up to be of approximately equal potency by assuming a potency for the unknown ( $A_U$ ). Each result is converted to a logarithm, and the means of the log effective doses for the standard ( $\bar{X}_S$ ) and the unknown ( $\bar{X}_U$ ) are calculated. The

potency ratio of unknown to standard before adjustment by the assumed potency ( $R'$ ) is the antilog of  $M'$

where

$$M' = \bar{X}_S - \bar{X}_U \quad \dots (6)$$

The variance of  $M'$  is the sum of the variances of the two means and is calculated from equation 7.

$$S_x^2 = S_x^2 \left[ \frac{1}{N_s} + \frac{1}{N_u} \right] \quad \dots (7)$$

$$S_x^2 = \frac{\left[ \frac{\sum X_S^2 - \frac{(\sum X_S)^2}{s}}{N_s} \right] + \left[ \frac{\sum X_U^2 - \frac{(\sum X_U)^2}{u}}{N_u} \right]}{N_s + N_u - 2} \quad \dots (8)$$

$N_S$  and  $N_U$  are the numbers of animals treated with standard and unknown and  $\sum_s$  and  $\sum_u$  represent the summation of results obtained with the two preparations. Fiducial limits are calculated as

$$\text{antilog} (M' \pm t_{S_M}) \quad \dots (9)$$

The degrees of freedom for  $t$  are equal to  $(N_S + N_U - 2)$ . The estimate of potency ( $R$ ) is equal to antilog ( $M$ ) where

$$M = M' + \log A_U \quad \dots (10)$$

with fiducial limits

$$\text{antilog} (M \pm t^* S_M) \quad \dots (11)$$

In this way  $s_M$  is equal to  $S_M$ . Limits calculated by Equation 11 may be expressed as percentage of the stated potency or as percentages of the estimated potency.

In a valid assay, the variance of  $X_S$  should be the same as that for  $X_U$ , apart from sampling errors. If necessary this condition may be tested by calculating the variances and dividing the larger by the smaller, to obtain a variance ratio.

The variance of  $X_S$  is calculated from Equation 12

$$S_{X_s}^2 = \frac{\sum_s X_s^2 - \frac{(\sum_s X_s)^2}{N_s}}{N_s - 1} \quad \dots (12)$$

and similarly for  $S_{X_u}^2$

The variance ratio ( $F$ ) distribution is given in Table 6 but it should be noted that for this test the upper values given correspond to  $P = 0.05$ , and the lower values to  $P = 0.01$ .

Example 3 – Direct assay with digitalis using guinea-pigs

Preparation	Estimate of individual lethal dose (ml/kg)	X = log lethal dose
Standard Preparation (S)	1.12	0.0492
	1.44	0.1584
	1.06	0.0253
	1.14	0.0569
	1.26	0.1004
	1.20	0.0792
Total $\sum X_s$		0.4694
Mean $\bar{X}_s$		$\frac{1}{6}(0.4694)$ =0.0782
Test preparation (U)	1.24	0.0934
	1.38	0.1399
	1.08	0.0334
	1.41	0.1492
	1.20	0.0792
	1.09	0.0374
Total $\sum X_u$		0.5325
Mean $\bar{X}_u$		$\frac{1}{6}(0.5325)$ =0.0888

The variance  $S_x^2$  is calculated as

$$S_x^2 = \frac{1}{10} \left[ \left\{ (0.0492)^2 + \dots + (0.0792)^2 - \frac{(0.4694)^2}{6} \right\} + \left\{ (0.0934)^2 + \dots + (0.0374)^2 - \frac{(0.5325)^2}{6} \right\} \right] = 0.002310$$

From Equation 7,  $S_M^2 = 0.002310 \left( \frac{1}{6} + \frac{1}{6} \right) = 0.000770$

So that  $s_M = 0.0277$

At P= 0.05 with 10 degrees of freedom, t = 2.23 (Table 1)

$M' = 0.0782 - 0.0888 = -0.0106 = \bar{1}.9894$

If the concentrations of the two solutions are equal, as in this example, then the assumed potency ratio equals unity and  $M = M'$ . Potency ratio (Test/Standard) = 0.98.

Fiducial limits to potency ratio

= antilog [- 0.0106 ± (2.23) (0.0277)]

= antilog 1.9276 and antilog 0.0512 = 0.85 to 1.13

If the test concentration (mg/ml) had been twice that of the standard, then the assumed potency ratio A would be 0.5. M would then be equal to  $M' + \log 0.5$ .

**5.7.7. Assays depending upon Measured Effects.**

**5.7.7.1. Validity and other conditions**

These tests involve the measurement of the effects of fixed quantities of drugs on individual biological systems, e.g. a whole animal, isolated animal tissue or a culture of bacteria.

Each treatment which consists of a fixed dose of a standard ( $s_1, s_2$ ) or of an unknown ( $u_1, u_2$ ) to be assayed, is administered to a certain number (n) of experimental units (animals, cultures, tubes, etc. ) and n responses are recorded, one per unit. The responses (y) may be increases in the weights of animals, organ weights, the sizes of zones of inhibition of bacterial growth, measurements of the turbidity of cultures, etc.

The methods of calculation described below may be used to evaluate the results of such assays provided that the following conditions are fulfilled.

1. The experimental units have been randomly assigned to the different treatments (Sections 5.7.4 and 5.7.7.2)
2. The responses to each treatment are normally distributed.
3. The standard deviation of the response is independent of the level of response, i.e. is constant for each treatment.
4. The relationship between the logarithm of the dose and the response can be represented by a straight line, over the range of doses used.
5. For any test preparation in the assay, the straight line (defined in 4) must be parallel to that for the standard.

If conditions 3 and 4 are not met, it may be possible to remedy the situation by using a different response metameter, i.e by transforming the response, e.g. by taking its square or logarithm before proceeding with the calculation.

It may be possible to assume conditions 2, 3 and 4 from preliminary studies of the method. Condition 4 (linearity) can only be verified in assays where at least three dilutions of each preparation have been tested and monographs which specify the use of only two dilutions assume that linearity has been established in previous studies of the log dose – response curve. Condition 5 (parallelism) should be tested in every assay, i.e. there should never be less than two dilution of each preparation. It is also desirable that test preparations should be assayed at doses which give responses approximately equal to those obtained with the corresponding doses of the standard preparation.

If any of the five conditions is not met, the methods of calculation described here are unreliable and a special study



of the assay by an expert statistician will be required in order to decide what conclusions may be drawn from it.

When validity is established the potency of each unknown relative to that of the standard may be calculated and expressed as a potency ratio or converted to some unit appropriate to the preparation under examination, e.g. International Unit. Fiducial limits may also be estimated from each set of assay data.

In order to simplify the statistical analysis presented here it is necessary to impose the following restrictions on the assay design.

- (a) Each preparation in the assay must be tested at the same number of dilutions. Formulae are given for assays using two dose levels.
- (b) The ratio of adjacent doses must be constant for all treatments in the assay.
- (c) There are an equal number of responses to each treatment.

If one response is missing, it can be estimated by methods given in Section 5.7.7.6

**5.7.7.2. Assay Design**

The allocation of individuals to different treatments may be made in various ways.

*Random Design*

If the totality of experimental units (animals, tubes, etc.) appears to be reasonably homogeneous, with no indication that variability in response will be smaller within certain recognizable sub-groups, the allocation of the units to the different treatments should be made at random, e.g. by using a table of random numbers.

If sub-groups such as litters, physical positions or experimental days are likely to be more homogenous than the totality of units, the precision of the assay may be increased by introducing one or more restrictions into the design. A careful choice of balance over these restrictions permits irrelevant sources of variation to be eliminated

*Randomised Block*

In this design it is possible to segregate an identifiable source of variation, such as the sensitivity variation between litters of experimental animals or the variation between Petri dishes in a diffusion microbiological assay. The design requires that every treatment is applied once in every block (litter or Petri dish) and is only suitable when the block is large enough to accommodate all treatments.

*Cross-over Test*

This design is useful when the experiment can be subdivided into blocks but it is possible to apply only two treatments to each block, e.g. a block may be a single animal which can be

tested on two occasions. The design is intended to increase precision by eliminating the effects of differences between animals while balancing the effect of any difference between general levels of response at the two stages of the test. If two doses of a standard and of an unknown preparation are tested this is known as a twin cross-over test.

The experiment is divided into two parts separated by a suitable time interval. Animals are divided into 4 groups and each group receives one of the 4 treatments in the first part of the test. Animals which received one preparation in the first part of the test receive the other preparation on the second occasion and animals receiving small doses in one part of the test receive large doses in the other. The arrangement of doses is shown in Table 2.

Table 2 – Arrangement of doses in twin cross-over test

Group of animals	Day I	Day II
1	S <sub>1</sub>	u <sub>2</sub>
2	S <sub>2</sub>	u <sub>1</sub>
3	u <sub>1</sub>	S <sub>2</sub>
4	u <sub>2</sub>	S <sub>2</sub>

Whichever design is used, the allocation of experimental units to blocks should be made at random and the units should be kept under uniform conditions both before and during the experiment.

**5.7.7.3. Analysis of Variance**

Apart from some adjustments to the error term the basic analysis of data derived from an assay is the same for random and randomized block designs. This section gives formulae required to carry out the analysis and will be more easily understood by reference to the worked examples in section 5.7.8. Reference should also be made to the glossary of symbols (Section 5.7.3.). The formulae are appropriate for simple assays where a single unknown preparation (U) is compared with a standard preparation (S) and for multiple assays where several unknown (U.....Z) are included. The formulae for cross-over tests do not entirely fit the scheme and these are incorporated into Example. 5.

Table 3 - Formulae for assays with two does of each preparation

Dose and response	Standard ( <u>S</u> )	Ist test preparation ( <u>U</u> )	(h-1)st test preparation ( <u>Z</u> )
Low dose (total response)	S <sub>1</sub>	U <sub>1</sub>	Z <sub>1</sub>
High dose (total response)	S <sub>2</sub>	U <sub>2</sub>	Z <sub>2</sub>
For preparation (total response)	S <sub>1</sub> + S <sub>2</sub> = S	U <sub>1</sub> + U <sub>2</sub> = U	Z <sub>1</sub> + Z <sub>2</sub> = Z
Linear contrast	S <sub>2</sub> + S <sub>1</sub> = L <sub>S</sub>	U <sub>2</sub> + U <sub>1</sub> = L <sub>U</sub>	Z <sub>2</sub> + Z <sub>1</sub> = L <sub>Z</sub>

Having considered the points discussed in Section 5.7.7.1 and transformed the responses (y) if necessary the values of y should be assumed over treatment and each preparation, as shown in table 3. The linear contrasts, which relate to the slopes of the log dose – response lines, should also be derived. The total variation in responses, caused by the different treatments, is now partitioned as shown in table 4, the sums of squares being derived from the values obtained in Table 2. K represents the square of the total of all responses recorded for the assay divided by the total number of responses.

Having considered the points discussed in Section 5.7.7.1 and transformed the responses (y) if necessary the values of y should be assumed over treatment and each preparation, as shown in table 3. The linear contrasts, which relate to the slopes of the log dose – response lines, should also be derived. The total variation in responses, caused by the different treatments, is now partitioned as shown in table 4, the sums of squares being derived from the values obtained in Table 2. K represents the square of the total of all responses recorded for the assay divided by the total number of responses.

Table 4 – Tests of validity for two-dose assays

Source of variation	Degrees of freedom (f)	Reduced sum of squares
Preparations	h – 1	$\frac{(S^2 + U^2 + \dots + Z^2)}{2n} - K$
Regression	1	$\frac{(L_s + L_u + \dots + L_z)^2}{2nh} = E$
Parallelism	h – 1	$\frac{(L_s^2 + L_u^2 + \dots + L_z^2)}{2n} - E$

The residual error of the assay is obtained by subtracting the variations allowed for in the design from the total variation in response (Table 5). In this Table  $\sum \hat{O}y^2$  represents the sum of

squares for all responses recorded in the assay. It should be noted that the reduced sum of squares for treatments is equal to the reduced sums of square in Table 4 totalled over all sources of variation.

**5.7.7.4. Tests of Validity**

In order to assess the significance of the sources of variation listed in Table 4 each of the reduced sums of squares, obtained from that table, should be divided by the corresponding number of degrees of freedom to give mean squares. The mean square for residual error ( $s^2$ ) is a similar quotient derived from the appropriate line in Table 5.

The mean square for each variable to be tested is now expressed as a ratio to  $s^2$  and the significance of these values (known as F ratios) assessed by use of Table 6. Critical values of F, for a chance occurrence of 5 per cent or 1 per cent, may be found by reference to the column of the Table corresponding to the number of degrees of freedom associated with the mean square for the variable being tested ( $f_1$ ) and the row of the Table corresponding to the number of degrees of freedom associated with  $s^2$  ( $f_2$ ). If a calculated F value is larger than the tabulated value, the variable being tested is said to be ‘significant’ at the level of probability indicated, i.e. 0.05 or 0.01.

Assay results are said to be ‘statistically valid’ if the outcome of these tests is as follows.

1. The regression term should be highly significant, i.e. the calculated F should be larger than the tabulated F for P = 0.01. This indicates that the slope of the log dose–response line is satisfactory.
2. The parallelism term should not be significant (see condition 5, section 5.7.7.1)

When statistical validity is established potencies and fiducial limits may be estimated by methods described in the next section.

Table 5 – Estimation of residual error

Source of variation	Degrees of freedom (f)	Reduced sum of squares	
		Random design	Randomised block
Treatments	k – 1	$\frac{(S_1^2 + S_2^2 + \dots + Z_k^2)}{n} - K$	$\frac{(S_1^2 + S_2^2 + \dots + Z_k^2)}{hd} - K$
Blocks (rows)	n - 1	—	$\frac{(R_1^2 + R_2^2 + \dots + R_n^2)}{hd} - K$
Residual error	By subtraction	*	*
Total	N – 1	$\sum y^2 - K$	$\sum y^2 - K$

\* Obtained by subtracting from the total reduced sum of squares all other reduced sums of squares calculated for the particular design.

Table 6 – The variance ratio (F) distribution Degrees of

Degrees of freedom for denominator (f <sub>2</sub> )	Degrees of freedom for numerator (f <sub>1</sub> )									
	1	2	3	4	5	6	7	8	20	Infinity
12	<b>4.75</b>	<b>3.89</b>	<b>3.49</b>	<b>3.26</b>	<b>3.11</b>	<b>3.00</b>	<b>2.91</b>	<b>2.85</b>	<b>2.54</b>	<b>2.30</b>
	9.33	6.93	5.95	5.41	5.06	4.82	4.65	4.50	3.86	3.36
15	<b>4.54</b>	<b>3.68</b>	<b>3.29</b>	<b>3.06</b>	<b>2.90</b>	<b>2.79</b>	<b>2.71</b>	<b>2.64</b>	<b>2.33</b>	<b>2.07</b>
	8.68	6.36	5.42	4.89	4.56	4.32	4.14	4.00	3.37	2.87
20	<b>4.35</b>	<b>3.49</b>	<b>3.10</b>	<b>2.87</b>	<b>2.71</b>	<b>2.60</b>	<b>2.51</b>	<b>2.45</b>	<b>2.12</b>	<b>1.84</b>
	8.10	5.85	4.94	4.43	4.10	3.87	3.70	3.56	2.94	2.42
30	<b>4.17</b>	<b>3.32</b>	<b>2.92</b>	<b>2.69</b>	<b>2.53</b>	<b>2.42</b>	<b>2.33</b>	<b>2.27</b>	<b>1.93</b>	<b>1.62</b>
	7.56	5.39	4.51	4.02	3.70	3.47	3.30	3.17	2.55	2.01
60	<b>4.00</b>	<b>3.15</b>	<b>2.76</b>	<b>2.53</b>	<b>2.37</b>	<b>2.25</b>	<b>2.17</b>	<b>2.10</b>	<b>1.75</b>	<b>1.39</b>
	7.08	4.98	4.13	3.65	3.34	3.12	2.95	2.82	2.20	1.60
Infinity	<b>3.84</b>	<b>3.00</b>	<b>2.60</b>	<b>2.37</b>	<b>2.21</b>	<b>2.10</b>	<b>2.01</b>	<b>1.94</b>	<b>1.57</b>	<b>1.00</b>
	6.63	4.61	3.78	3.32	3.02	2.80	2.64	2.51	1.88	1.00

The upper bold values correspond to P = 0.05, the lower values to P = 0.01.

**5.7.7.5. Estimation of Potency and Fiducial Limits**

The mean response for each preparation ( $\bar{y}_s, \bar{y}_u, \dots, \bar{y}_z$ ) should first be calculated.

$$\bar{y}_s = \frac{S}{N_s} \quad \dots (13)$$

and similarly for the other preparations.

If I is the interval between adjacent log doses of any preparation, the common slope (b) for assays with two doses of each preparation is obtained from equation 14.

$$b = \frac{1}{\text{Inh}} (L_s + L_u + \dots + L_z) \quad \dots (14)$$

The logarithm of the potency ratio of a test preparation U(M' <sub>U</sub>) is

$$\frac{\bar{y}_u - \bar{y}_s}{b} \quad \dots (15)$$

The calculated potency is an estimate of the true potency of each unknown. Fiducial limits (which have a 95 per cent probability of including the true potency) may be calculated as the antilogarithms of Formula 16.

$$CM'_u \pm \frac{st\sqrt{C}}{b} \sqrt{\frac{1}{N_s} + \frac{1}{N_u} + \frac{(\bar{y}_s - \bar{y}_u)^2}{E - s^2 t^2}} \quad \dots (16)$$

$$\text{where, } C = \frac{E}{E - s^2 t^2} \quad \dots (17)$$

E is obtained for Table 4, s<sup>2</sup> is the residual error from Table 5 divided by its degrees of freedom and t is read from Table 1 according to degrees of freedom for s<sup>2</sup>.

For the balanced two dose assays described here the formula (16) for limits can be simplified to:

$$CM'_u \pm \sqrt{(C-1)(CM'_u)^2 + c' I^2} \quad \dots (18)$$

Where c' is a coefficient obtained from Table 7.

C is a measure of the significance of the regression and in an assay with a well-defined slope the value of C will be very close to unity.

Table 7 – Constant used in formula for fiducial limits: with two doses of each preparation values of c' are given below.

Number of test Preparations (h - 1)	1	2	3	4	5
Values of c'	1	3/2	2	5/2	3

The potency ratio (R<sub>U</sub>) and associated fiducial limits are obtained either by multiplying the values obtained from Formulae 15 and 18 by A<sub>U</sub> after antilogarithms have been taken or by adding log A<sub>U</sub> being taking antilogarithms.

**5.7.7.6. Missing Values**

In a balanced assay, an accident unconnected with the applied treatments may lead to the loss of one or more responses, for example, because an animal dies. Full statistical analysis is then much more complicated. However, if only one value is missing, an approximate analysis can keep the simplicity of the balanced design by replacing the missing response by a calculated value. The loss of information is taken into account by diminishing the degrees of freedom, for the total sum of squares and for the residual error, by unity, and using one of the following equations for the missing value.

*Random Design*

In a completely randomized assay the missing value can be replaced by the arithmetic mean of the other responses to the same treatment.

*Randomised block*

The missing value ( $y'$ ) is obtained by use of Equation 19.

$$y' = \frac{nB' + kT' - G'}{(n-1)(k-1)} \dots (18)$$

Where  $B'$  is the sum of responses in the block containing the missing value,  $T'$  the corresponding treatment total and  $G'$  is the sum of all responded in the assay.

*Example:* Suppose that the response to dose  $u_1$  in the first block of the heparin assay (Example 4 : Section 5.7.8.1) was missing.

$$B' = 12.440, T' = 7.122, G' = 56.926, y' = 2.371$$

The value 2.371 would appear in the table of responses in place of 2.352 and calculation would proceed as in Example 4 but the degrees of freedom for 'error' would be 14 and for 'total' they would be 22.

*Cross-over Design*

If an accident leading to loss of values occurs in a twin cross-over design, consultation with a statistician is essential, because the appropriate equations depend upon the particular treatment combinations.

Similarly, consult a statistician if more than one responses are missing in any of the designs.

**5.7.8. Examples of Assays Depending upon Measured Effects**

This section consists of worked examples illustrating the application of formulae described in section 5.7.7.

Formulae for a two-dose multiple assay arranged in randomized block design are used in Example 4.

Some extra notation has been introduced in the example of a cross-over assay (Example 5) for, in order to carry out analysis, it is necessary to form treatment totals and linear contrasts for each day of the test, separately AI or II added to the subscript of a symbol indicates that the value relates to the first or second occasion of testing.  $D_I$  and  $D_{II}$  are the response totals for days I and II and  $B_1, B_2, \dots, B_{2n}$  are the sums of the paired responses for each experimental unit (i.e. animal)

**5.7.8.1. Example 4 : Two – Dose Multiple Assay, Randomized Block Design**

*Assay of heparin by consideration of blood clotting*

The standard preparation contains 130 units per mg. Doses of the standard used in the assay were 1.4 and 2.0 units per ml. Both test preparations were assigned nominal potencies of 130 units per mg and doses were prepared equivalent to those of the standard. Table 8 summarizes the data.

$$\text{Correction term } K = \frac{(\sum y)^2}{N} = \frac{(59.278)^2}{24} = 146.41172$$

Sum of squares for blocks, using the formula in Table 5, is given by

$$\frac{(R_1^2 + R_2^2 + R_3^2 + R_4^2)}{6} - K = 0.00060$$

The other sums of squares (see Table 9) are obtained in the same manner.

*Validity of assay*

The analysis of variance satisfactorily confirmed significant regression between dose levels and with a sum of squared for

Table 8 – Response metameter  $y$  (logarithm of coagulation time in seconds)

Block	Standard $\underline{S}$		Test $\underline{U}$		Test $\underline{Z}$		Block total
	$s_1$	$s_2$	$u_1$	$u_2$	$z_1$	$z_2$	
1	2.348	2.591	2.352	2.588	2.335	2.578	$R_1 = 14.792$
2	2.371	2.571	2.365	2.582	2.352	2.568	$R_2 = 14.809$
3	2.342	2.580	2.380	2.601	2.339	2.565	$R_3 = 14.807$
4	2.358	2.594	2.377	2.618	2.346	2.577	$R_4 = 14.870$



Table 9 – Response totals and contrasts

Dose and response	Preparation			
	Standard S	Test U	Test Z	Total
Low dose	S <sub>1</sub> = 9.419	U <sub>1</sub> = 9.474	Z <sub>1</sub> = 9.372	
High dose	S <sub>2</sub> = 10.336	U <sub>2</sub> = 10.389	Z <sub>2</sub> = 10.288	
Preparation totals	S = 19.755	U = 19.863	Z = 19.660	Σ y = 59.278
Linear contrasts	L <sub>S</sub> = 0.917	L <sub>U</sub> = 0.915	L <sub>Z</sub> = 0.916	Σ L = 2.748

Table 10 – Analysis of variance

Source of variation	Degrees of freedom	Sum of squares	Mean Square	F	P
Preparations	2	0.00258	0.00129		
Regression	1	0.31465	0.31465	2689	<0.01
Parallelism	2	0.00000	0.00000	0	>0.05
Treatments	5	0.31723	0.06345		
Blocks	3	0.00060	0.00020		
Error	15	0.00176	0.000117		
Total	23	0.31959			

deviation from parallelism being equal to zero there was no question of the departure from parallelism of the regression lines being significant.

*Calculation of potency ration and fiducial limits*

Doses administered were 1.4 and 2.0 units per ml;

$$I = \log 2.0 - \log 1.4 = 0.1549$$

t = 2.13 from Table 1 with 15 degrees of freedom.

$$b = \frac{\Sigma L}{\ln h(d-1)} = \frac{2.748}{[(0.1549)\{(4 \times 3) \times (2-1)\}]} = 1.4784$$

$$\bar{y}_s = 19.755/8 = 2.4694, \bar{y}_u = 2.4829, \bar{y}_z = 2.4575$$

$$M'_u = (\bar{Y}_u - \bar{Y}_s)/b = 0.00913, M_u = M'_u \text{ since } \log A_U = 0$$

Potency ratio for test U = antilog M<sub>u</sub> = 1.02.

$$C = E/(E-s^2t^2) = 0.31465/[0.31465 - (0.000117)(2.13)^2] = 1.00170$$

c' = 3/2 from Table 7.

Fiducial limits potency ration given by

$$A_u \text{ antilog} \left[ CM'_u \pm \sqrt{(C-1)(CM'_u)^2 + c'I^2} \right]$$

$$= \text{antilog} \left[ (0.009146) \pm \sqrt{(0.0017)(0.0000835 + 0.0359910)} \right]$$

$$= \text{antilog} [(0.009146) \pm (0.007831)]$$

$$= \text{antilog} (0.0013) \text{ and } \text{antilog} (0.0170)$$

Fiducial limits to potency ratio of test U are 1.00 to 1.04. Using the same procedure, potency ratio for test Z is 0.98 with fiducial limits 0.96 to 1.00

**5.7.8.2. Example 5 : Twin Cross-Over Assay**

*Assay of insulin using rabbits*

Standard doses used were 1 and 2 units per ml. Equivalent doses of the test solution were prepared based on an assumed potency of 40 units per ml. The rabbits were injected subcutaneously with 0.5 ml of the appropriate solutions, according to the design in Table 11.

Table 11 – Arrangements of treatments

Day	Group of rabbits			
	1	2	3	4
I	S <sub>1</sub>	S <sub>2</sub>	U <sub>1</sub>	U <sub>2</sub>
II	U <sub>2</sub>	U <sub>1</sub>	S <sub>2</sub>	S <sub>1</sub>

The analysis of variance is more complicated for this assay than for the other designs given because the component of the sum of squares due to parallelism is not independent of the component due to rabbit differences.

Table 12 – Response y (sum of blood glucose readings (mg per cent) at 1½ hours)

Group 1			Group 2			Group 3			Group 4		
s <sub>1</sub>	u <sub>2</sub>	Total	s <sub>2</sub>	u <sub>1</sub>	Total	u <sub>1</sub>	s <sub>2</sub>	Total	u <sub>1</sub>	s <sub>1</sub>	Total
112	104	216	65	72	137	105	91	196	118	114	262
126	112	238	116	160	276	83	67	150	119	149	268
62	58	120	73	72	145	125	67	192	42	51	93
86	63	149	47	93	140	56	45	101	64	107	171
52	53	105	88	113	201	92	84	176	93	117	210
110	113	223	63	71	134	101	56	157	73	128	201
116	91	207	50	65	115	66	55	121	39	87	126
101	68	169	55	100	155	91	68	159	31	71	102

Table 13 – Response totals and contrasts

Dose	Test		
	Standard <u>S</u>	Test <u>U</u>	Total
Day I			
Low dose	S <sub>11</sub> = 765	U <sub>11</sub> = 719	
High dose	S <sub>21</sub> = 557	U <sub>21</sub> = 579	
Total	S <sub>I</sub> = 1322	U <sub>I</sub> = 1298	D <sub>I</sub> = 2620
Day II			
Low dose	S <sub>111</sub> = 854	U <sub>111</sub> = 746	
High dose	S <sub>211</sub> = 533	U <sub>211</sub> = 662	
Total	S <sub>II</sub> = 1387	U <sub>II</sub> = 1408	D <sub>II</sub> = 2795
Preparation total	S = 2709	U = 2706	Σy = 5415
Linear contrast			
Day I	L <sub>S1</sub> = -208	L <sub>U1</sub> = -140	L <sub>I</sub> = -348
Day I	L <sub>S11</sub> = -321	L <sub>U11</sub> = -84	L <sub>II</sub> = -405
Total	L <sub>S</sub> = -529	L <sub>U</sub> = -224	ΣL = -753

Testing of the parallelism of the regression lines involves a second error mean square term obtained by subtracting the parallelism component and two ‘interaction’ components from the component due to rabbit differences.

Three ‘interaction’ components are present in the analysis of variances due to replication within each group :

days × preparations, days × regression, days × parallelism

These terms indicate the tendency for the components (preparation, regression and parallelism) to vary from day to

day. The corresponding F tests thus provide checks on these aspects of assay validity. If the values of F obtained are significantly high, care should be exercised in interpreting the results of the assay, and if possible the assay should be repeated.

The values for sums of squares were obtained using the quantities in Tables 12 and 13.

$$\text{Correction term } K = \frac{\sum(y)^2}{N} = \frac{(5415)^2}{64} = 458160$$

$$\text{Total} = (\sum y)^2 - K = 511583 - 458160 = 53423$$

$$\begin{aligned} \text{Blocks} &= \frac{B_1^2 + B_2^2 + B_{2n}^2}{2} - K \\ &= \frac{(216)^2 + (238)^2 + \dots + (102)^2}{2} - 458160 = 39795 \end{aligned}$$

$$\begin{aligned} \text{Preparations} &= \frac{S^2 + U^2}{2n} - K \\ &= \frac{(2709)^2 + (2706)^2}{32} - 458160 = 0 \end{aligned}$$

$$\text{Days} = \frac{D_1^2 + D_{II}^2}{2n} - K = \frac{(2620)^2 + (2795)^2}{32} - 458160 = 478$$

$$\text{Regression} = \frac{(L_s + L_u)^2}{N} = \frac{(-753)^2}{64} = 8860 = E$$

$$\begin{aligned} \text{Parallelism} &= \frac{(L_s^2 + L_u^2)}{2n} - E \\ &= \frac{(529)^2 + (224)^2}{32} - 8860 = 1453 \end{aligned}$$

$$\begin{aligned} \text{Days} \times \text{Regression} &= \frac{L_I^2 + L_{II}^2}{2n} - E \\ &= \frac{(348)^2 + (405)^2}{32} - 8860 = 50 \end{aligned}$$

$$\begin{aligned} \text{Days} \times \text{Parallelism} &= \frac{L_{SI}^2 + L_{SII}^2 + L_{UI}^2 + L_{UII}^2}{n} - E \\ &\quad - \text{Parallelism} - \text{days} \times \text{Regression} \\ &= \frac{(208)^2 + (321)^2 + (140)^2 + (84)^2}{16} - 8860 - 1453 - 50 = 447 \end{aligned}$$

$$\begin{aligned} \text{Days} \times \text{Preparations} &= \frac{S_I^2 + S_{SII}^2 + U_I^2 + U_{II}^2}{n} - K \\ &\quad - \text{days} - \text{Preparations} \\ &= \frac{(1322)^2 + (1387)^2 + (1298)^2 + (1408)^2}{16} - 458160 - 478 \\ &= 32 \end{aligned}$$

$$\begin{aligned} \text{Error (I)} &= \text{Blocks} - \text{Parallelism} - (\text{Days} \times \text{Preparation}) \\ &\quad - (\text{Days} \times \text{Regression}) = 38260 \end{aligned}$$

$$\begin{aligned} \text{Error (II)} &= \text{Total} - \text{Blocks} - \text{Preparation} - \text{Regression} \\ &\quad - \text{Days} - (\text{Days} \times \text{Parallelism}) = 3843 \end{aligned}$$

*Validity of assay*

The analysis of variances confirmed that the data fulfilled the necessary conditions for a satisfactory assay.

- (i) Significant regression. The F – value 64.5 for regression, calculated using the mean square of error (II), is higher than the interpolated critical value given in Table 6 for P= 0.01, f<sub>1</sub> = 1, f<sub>2</sub> = 28.

- (ii) Departure from parallelism of the regression lines. The test for parallelism in a cross-over assay is not very sensitive, being based on the mean square of error (I) which depends on variation between the rabbits used. The F- value of 1.06 is less than the interpolated critical value in Table 6 for P= 0.05, f<sub>1</sub> = 1, f<sub>2</sub> = 28

- (iii) None of the three interaction components was significant, the three F – values being 0.02, 0.04 and 3.26.

*Calculation of potency estimate and fiducial limits*

I = log 2.0 – log 1.0 = 0.3010, t = 2.05 with 28 degrees of freedom from Table 1. For a twin cross – over design, we have

$$b = \frac{2(L_s + L_u)}{NI} = \frac{2(-529 - 224)}{64 \times 0.0310} = -78.17,$$

$$\bar{y}_s = \frac{S}{2n} = \frac{2709}{32} = 84.66, \bar{y}_u = 84.56$$

$$M'_u = (\bar{y}_u - \bar{y}_s) / b = 0.0013$$

$$A_U = 40 \text{ Units per ml}, M_u = M'_u + \log A_u = 1.6034$$

$$C = E / (E - s^2 t^2) = 8860 / [8860 - 137.3(2.05)^2] = 1.0697$$

c' = 1 from Table 7.

log fiducial limits to potency of test U are given by

$$CM'_u \pm \sqrt{(C-1)(CM'_u)^2 + c'I^2} + \log A_U$$

i.e. (1.0697 × 0.0013)

$$\begin{aligned} &\pm \sqrt{(0.0697)[(1.0697)(0.0013)^2 + (0.03010)^2]} + 1.6021 \\ &= 0.0014 \pm \sqrt{0.00632} + 1.6021 = 1.6035 \pm 0.0795 \end{aligned}$$

Log fiducial limits = 1.5240 and 1.6830,

Table 14 – Analysis of variance

Source of variation	Degrees of freedom	Sum of squares	Mean squares	F	P
Parallelism	1	1453	1453	1.06	>005
Days × preparations	1	32	32	0.02	>0.05
Days × regression	1	50	50	0.04	>0.05
Error (I)	28	38260	1366		
Blocks (rabbits)	31	39795	1284	9.35	
Preparations	1	0	0	0.00	>0.05
Regression	1	8860	8860	64.5	<0.01
Days	1	478	478	3.48	>0.05
Days × parallelism	1	447	447	3.26	>0.05
Error (II)	28	3843	137.3		
Total	63	53423			

N = 64, total number of responses ; n = 16, number of replicated per dose.

Fiducial limits to potency of test U are, therefore, 33.4 to 48.2 units per ml.

**5.7.9. Assays depending upon Quantal effects**

**5.7.9.1. Introduction**

In certain assays, such as that for insulin by subcutaneous injection into mice, it is impossible or excessively laborious to measure the effect on each animal on a quantitative scale. Instead, an effect such as death or hypoglycemic symptoms may be observed as either occurring or not occurring in each

animal, and the result depends on the number of animals in which it occurs, such assays are called quantal or all-or-none. The situation is very similar to that described for quantitative assays, but in place of the n separate response to each treatment a single value is recorded, i.e. the percentage of animals in each treatment group showing a positive effect. When these percentages are plotted against the logarithms of the doses the resulting curve will tend to be sigmoid (S-shaped) rather than linear. A more satisfactory straight line relationship is obtained if a mathematical function of the percentage is used as response, in the statistical analysis of

Table 15 – Probits corresponding to percentages

	0	1	2	3	4	5	6	7	8	9
0	–	2.67	2.95	3.12	3.25	3.36	3.45	3.52	3.59	3.66
10	3.72	3.77	3.82	3.87	3.92	3.96	4.01	4.05	4.08	4.12
20	4.16	4.19	4.23	4.26	4.29	4.33	4.36	4.39	4.42	4.45
30	4.48	4.50	4.53	4.56	4.59	4.61	4.64	4.67	4.69	4.72
40	4.75	4.77	4.80	4.82	4.85	4.87	4.90	4.92	4.95	4.97
50	5.00	5.03	5.05	5.08	5.10	5.13	5.15	5.18	5.20	5.23
60	5.25	5.28	5.31	5.33	5.36	5.39	5.41	5.44	5.47	5.50
70	5.52	5.55	5.58	5.61	5.64	5.67	5.71	5.74	5.77	5.81
80	5.84	5.88	5.92	5.95	5.99	6.04	6.08	6.13	6.18	6.23
90	6.28	6.34	6.41	6.48	6.55	6.64	6.75	6.88	7.05	7.33
	0.00	0.1	0.2	0.3	0.4	0.5	0.6	0.7	0.8	0.9
99	7.33	7.37	7.41	7.46	7.51	7.58	7.65	7.75	7.88	8.09

Table 16 – Weighting coefficients corresponding to probits

	Probits				
	1	2	3	4	
0.0	0.001	0.015	0.131	0.439	–
0.1	0.001	0.019	0.154	0.471	0.9
0.2	0.001	0.025	0.180	0.503	0.8
0.3	0.002	0.031	0.208	0.532	0.7
0.4	0.002	0.040	0.238	0.558	0.6
0.5	0.003	0.050	0.269	0.581	0.5
0.6	0.005	0.062	0.302	0.601	0.4
0.7	0.006	0.076	0.336	0.616	0.3
0.8	0.008	0.092	0.370	0.627	0.2
0.9	0.011	0.110	0.405	0.634	0.1
–	0.015	0.131	0.439	0.637	0.0
	8	7	6	5	
	Probits				



assay data, rather than the untransformed percentages. The most commonly used transformation is that of 'probit'.

**5.7.9.2. Modified Probit Method**

The approximate method of analysis, described in this section, can be used provided that percentage of 0 or 100 do not occur in the data.

As shown in Example 6, the percentage of animals giving a positive response to each treatment is converted to a probit by use of table 15. For the purpose of calculation these probits are now equivalent to response values (y). A weighting coefficient (w), corresponding to each probit, is obtained from table 16.

Formulae for the sums of squares, required in the analysis of variance, are the same as those used for quantitative assays (Table 3) with the exception of the error term (s<sup>2</sup>) which should be calculated from Equation 20.

$$S^2 = \frac{k}{n \sum w} \dots (20)$$

Where k is the number of treatments, n is the number of animals tested in each treatment group and  $\sum w$  is the sum of the weighting coefficients.

The potency and fiducial limits are calculated by use of Formulae 15 and 18.

This approximate method will give results close to those obtained with the general probit method when percent responses for low and high doses are evenly spaced about 50 per cent. This implies that the weighting coefficients (w) are approximately equal at each treatment level in assays with two doses of each preparation.

**5.7.9.3. Example 6: Two-Dose Quantal Assay, Simplified Probit Method**

*Assay of insulin by subcutaneous injection in mice*

Standard doses administered were 24 and 40 milliUnits per mouse, contained in a volume of 0.25 ml. Equivalent test doses

used were prepared assuming the concentration of the test solution to be 40 units per ml.

A positive response was defined as a convulsion due to hypoglycaemia within 75 minutes of a subcutaneous injection of insulin (Table 17).

Table 17 – Positive responses from groups of 24 mice

Test Response	Standard S		Test U	
	s <sub>1</sub>	s <sub>2</sub>	u <sub>1</sub>	u <sub>2</sub>
Number of positive response	8	21	10	20
Percentage response	33.3	87.5	41.7	83.3

$$\text{Correction term, } K = \frac{(S+U)^2}{k} = \frac{(21.48)^2}{4} = 115.3476$$

The values for sums of squares relating to preparations, regression and parallelism were obtained from the formulae in Table 5, taking n=1.

$$\begin{aligned} \text{Preparation} &= \frac{(S^2 + U^2)}{2} - K \\ &= \frac{[(10.73)^2 + (10.75)^2]}{2} - 115.3478 = 0.0001 \end{aligned}$$

$$\text{Regression} = \frac{(L_s + L_u)^2}{4} = \frac{(2.76)^2}{4} = 1.9044 = E$$

$$\begin{aligned} \text{Parallelism} &= \frac{(L_s^2 + L_u^2)}{2} - E \\ &= \frac{[(1.59)^2 + (1.17)^2]}{2} - 1.9044 = 0.0441 \end{aligned}$$

Error mean square is estimated by

$$\frac{K}{\sum nw} = \frac{4}{24(0.595 + 0.384 + 0.626 + 0.452)} = 0.0810$$

Table 18 – Probit transformation, response totals and contrasts

Test Response	Standard S		Test U		Total
	s <sub>1</sub>	s <sub>2</sub>	u <sub>1</sub>	u <sub>2</sub>	
Probit response (Table 15)	S <sub>1</sub> = 4.57	S <sub>2</sub> = 6.16	U <sub>1</sub> = 4.79	U <sub>2</sub> = 5.96	
Weight w (Table 16)	0.595	0.384	0.626	0.452	
Preparation totals	S = S <sub>1</sub> + S <sub>2</sub> = 10.73		U = U <sub>1</sub> + U <sub>2</sub> = 10.75		Σy = 21.48
Linear contrast	L <sub>s</sub> = S <sub>2</sub> - S <sub>1</sub> = 1.59		L <sub>u</sub> = U <sub>2</sub> - U <sub>1</sub> = 1.17		ΣI = 2.76

Table 19 – Analysis of variance

Source of variation	Degree of freedom	Sum of squares	Mean of square	F	P
Preparations	1	0.0001	0.0001		
Regression	1	1.9044	1.9044	23.51	<0.01
Parallelism	1	0.0441	0.0441	0.54	>0.05
Error	Infinite		0.0810		

*Validity of assay*

Significant regression between dose – levels and no suggestion of departure from parallelism of the individual regression lines indicate a satisfactory assay from which a potency estimate may be calculated.

*Calculation of potency estimate and fiducial limits*

$I = \log 40 - \log 24 = 0.2219$ ,  $t = 1.96$  with infinite degrees of freedom (Table 1).

$$b = \frac{(L_s + L_u)}{Ih(d-1)} = \frac{2.76}{0.2219 \times 2} = 6.2190$$

$$\bar{y}_s = \frac{S}{2} = 5.385; \bar{y}_u = \frac{U}{2} = 5.375$$

$$M'_u = \frac{\sum W M}{\sum W} = \frac{(\bar{y}_u - \bar{y}_s)}{b} = \frac{(0.01)}{6.2190} = 0.0016$$

$$M_u = M'_u + \log A_u = 0.0016 + 1.6021$$

$$R_u = 40.2 \text{ Units per ml.}$$

$$C = E/(E - s^2 t^2) = 1.9044/[1.9044 - (0.08100)(1.96)^2] = 1.1953$$

$$c' = 1 \text{ from Table 7.}$$

Log fiducial limits to potency of test U are given by

$$CM'_u \pm \sqrt{(C-1)(CM'_u)^2 + c'I^2} + \log A_u \quad \dots (22)$$

giving fiducial limits of 32.1 to 50.4 Units per ml. Using the full method of probit analysis a potency estimate of 40.9 Units per ml was obtained with limits of 32.6 to 51.4 Units per ml.

**5.7.10. Combination of Potency Estimates**

**5.7.10.1. Introduction**

When the same preparation has been assayed several times it is often desirable to combine the resulting set of potencies into a single value, giving an overall potency that represents all the information available. There are several methods for combining the results of repeated assays, the most theoretically acceptable being the most difficult to apply.

A simple method of combination is described in Section 5.7.5, where the mean potency is derived from the antilogarithm of the arithmetic mean of the  $n'$  values of  $M$  and Formula 4 is used for the calculation of fiducial limits. This method has the disadvantage that assays with different numbers of response, or assays carried out with greater or less precision, will make equal contributions to the mean. A simple weighted method, which takes some account of these variations, is described in the following paragraphs.

In using the formulae from Section 5.7.5 or the ones in this section, two points should be taken care of

1. Estimates of log potency should be corrected by the assumed potency before they are combined.
2. The estimates should be independent, i.e. each should have been obtained from a separate assay which gave a set of responses to the standard preparation as well as to the unknown preparation under test.

**5.7.10.2. Weighted Mean Potency And Fiducial Limits**

It is assumed that the results of each of the  $n'$  assays have been analysed to given  $n'$  values of  $M$  with associated fiducial limits in logarithms, e.g. by use Formula 16.

For each assay the logarithmic fiducial interval ( $L$ ) is obtained by subtracting the lower limit from the upper. A weight ( $W$ ) for each value as that used in the calculation of fiducial limits, i.e. the value in Table 1 corresponding to degrees of freedom for the error mean square in the appropriate analysis of variance.

$$W = \frac{4t^2}{L^2} \quad \dots (21)$$

The products  $WM$  are formed for each assay and their sum divided by total weight for all assays to give the logarithm of the weighed mean potency  $\bar{M}$ , as shown in Equation 22.

The standard error of the mean potency ( $S_{\bar{M}}$ ) is taken to be the square root of the reciprocal of the total weight.

$$S_{\bar{M}} = \sqrt{1/\sum W}$$

and approximate confidential limits, which are expected to contain the true potency of the unknown preparation with 95 per cent probability, are obtained from the antilogarithms of the values given by Formula 24. The appropriate value of  $t$  in table 1 is that corresponding to the sum of the number of degrees of freedom for the error mean squares in the individual assays.

$$\bar{M} \pm ts_{\bar{M}}$$

This approximate method of combination should give satisfactory results, provided that C is less than 1.1 for each of the n' assays and also that the individual potency estimates form a homogeneous set. A test for homogeneity is described in Section 5.7.10.3.

### 5.7.10.3. Homogeneity of Potency Estimates

The homogeneity of a set of log potency estimates may be tested by means of the statistic approximate chi-square ( $\chi^2$ ) (Table 20).

A value of  $\chi^2$  is calculated by squaring the deviation of each value of M from the weighted mean ( $\bar{M}$ ), multiplying by the appropriate weight (W) and summing over all assays (Equation 25),

If the calculated  $\chi^2$  is smaller than the tabulated value corresponding to (n' - 1) degrees of freedom the potencies are homogeneous and the mean potency and limits obtained by the method of Section 5.7.10.2 will be meaningful.

If the calculated  $\chi^2$  is greater than the appropriate value in Table 20, potencies are heterogeneous. This means that the variation between individual estimates of M is greater than would have been predicated from the estimates of fiducial limits. Under these circumstance Formulae 22 and 24 are not applicable.

Table 20 – Value of  $\chi^2$  (P=0.95)

Degrees of Freedom	$\chi^2$ alue
1	3.84
2	5.99
3	7.81
4	9.49
5	11.07
6	12.59
7	14.07
8	15.51
10	18.31
15	25.00
20	31.41
25	37.65

## 5.8. Dimensions of Hard Gelatin Capsule Shells

Hard Gelatin Capsule Shells normally used for the incorporation of medicaments are cylindrical in shape but other shapes are also formed for special requirements. The shells of the capsules consists of two prefabricated cylindrical sections, one end of which is rounded and the other is open. The shells are of various sizes, usually designated by different numbers, 5 being the smallest and 000 the largest. Shells of sizes 0 to 4 are commonly use. The dimensions of hard gelatin capsule shells tend to vary with the content of moisture in them and the conditions under which they are stored or to which they are exposed. The chemical composition of the shells also influences the extent to which exposure to heat and moisture affects the dimensions. Nevertheless, the conventional dimensions (outside diameter, length and the double wall thickness) of the capsule shells of sizes 0 to 4 are provided in the table 1,2, and 3 for the guidance of users. It should be noted that any measurement of reasonable accuracy can be made only under controlled conditions of temperature and humidity. A temperature between 20° and 25° and a relative humidity between 45 per cent and 55 per cent are recommended.

Table 1 – Outside Diameter\*

Size	Cap (mm)	Body (mm)
0	7.57–7.69	7.26–7.38
1	6.85–6.97	6.56–6.68
2	6.28–6.40	6.01–6.13
3	5.75–5.87	5.50–5.62
4	5.25–5.37	5.00–5.12

\* Measure 3 mm from the cut end.

Table 2– Length

Size	Cap (mm)	Body (mm)
0	10.68–11.68	18.22–19.22
1	9.51–10.51	16.22–17.22
2	8.67–9.67	14.84–15.84
3	7.73–8.73	12.98–13.98
4	6.97–7.97	11.84–12.84

Table 3– Double Wall Thickness\*

Size	Cap (mm)	Body (mm)
0	0.187–0.223	0.177–0.213
1	0.182–0.218	0.175–0.211
2	0.180–0.216	0.173–0.209
3	0.178–0.214	0.170–0.206
4	0.176–0.212	0.164–0.200

\*Measure 3 mm from the cut end.

## 5.9 Microbial Quality of Preparations

This chapter provides acceptance criteria for the microbiological quality of pharmaceutical products, herbs, processed herbs and herbal products. They are not mandatory requirements.

### 1. Parenteral products.

Products required to be sterile as directed in the individual monograph comply with the test for sterility (2.2.11).

### 2. Preparations for topical use and for use in the respiratory tract.

Total viable aerobic count (2.2.9). Not more than  $10^2$  microorganisms (aerobic bacteria plus fungi) per g or per ml.

*Pseudomonas aeruginosa* (2.2.9). Absent in 1 g or 1 ml.

*Staphylococcus aureus* (2.2.9). Absent in 1 g or 1 ml.

### 3. Preparations for oral and rectal administration

Total viable aerobic count (2.2.9). Not more than  $10^3$  bacteria and not more than  $10^2$  fungi per g or ml.

*Escherichia coli* (2.2.9). Absent in 1 g or 1 ml.

### 4. Herbs, processed herbs and herbal products

Table

Tests	For oral administration	For topical use
Total aerobic count	$10^7$ per g or ml* $10^5$ per g or ml**	$10^7$ per g or ml
Total fungi	$10^5$ per g or ml* $10^3$ per g or ml**	$10^3$ per g or ml
<i>Staphylococcus aureus</i>	Absent in 1 g or 1 ml	Absent in 1 g or 1 ml
<i>Salmonella</i> sp	Absent in 10 g or 10 ml	Absent in 10 g or 10 ml
<i>Escherichia coli</i>	$10^2$ per g or ml* Absent in 1 g or 1 ml**	Absent in 10 g or 10 ml
<i>Pseudomonas aeruginosa</i>	Absent	Absent

\* Products to which boiling water is added before use

\*\* Products to which boiling water is not added before use

## 5.10 Reference Substances (IPRS)

Reference Substances are specifically required in many pharmacopoeial tests and assays. They are highly characterised substances selected for their critical attributes and suitability for the intended purpose. In the case of chemical substances, they are selected for their high purity. They are specimens of drug substances, impurities, degradation products, herbal-related and blood-related substances, excipients and test performance calibrators. They are not intended for use as drugs.

A Reference Substance is a primary standard that has the appropriate quality within a specified context and is accepted without requiring comparison to another substance.

Reference substances are certified by the Indian Pharmacopoeia Commission (IPC) or by laboratories notified by the IPC. They are maintained and distributed by the IPC or the agency(ies) nominated for this purpose

Where the letters RS appear after the italicised name of a substance in a test or assay in the individual monograph or in

an appendix, the relevant IP Reference Substance (IPRS) must be used.

In order to serve the intended purpose, it is important that each IPRS is properly stored, handled and used. Reference Substances should be stored in their original stoppered containers in a dry place, away from heat and protected from light. Special storage conditions, where necessary, are usually given on the label.

Unless an IPRS label states a specific potency or content, the material is taken as being 100.0 per cent pure for the purposes of the tests and assays. Where it is directed in a monograph that a reference solution of an IPRS be prepared for an assay or a test, it is intended that the standard shall be accurately weighed, taking into account the relatively large errors associated with weighing small quantities.

Where an IPRS is required to be dried before use, a suitable amount of the material should be transferred to a clean, dry vessel, weighed and then dried in the conditions stated on the label. On no account, should the original container be taken as the drying vessel and no specimen should be dried



repeatedly at temperatures above 25°. Where a titrimetric determination of water (2.3.43) is required, a fourfold dilution of the KF Reagent may be used.

In routine testing, a secondary standard commonly known as a working standard may be used provided it has been characterised and calibrated by comparison with a primary

reference substance and its suitability for carrying out the compendial tests has been established. For this purpose, the primary standard is the IPRS but may also be the British or European Pharmacopoeia Reference Substance or the USP Reference Standard or any other equivalent standard.

## 6. CONTAINERS

6.1	Containers	....
6.2.	Containers for Pharmaceutical Products	....
6.3.	Closures for containers of Parenteral Products	....
6.4.	Containers for Blood and Blood Components	...

## 6.1 Containers

A container for a pharmacopoeial article is intended to contain a drug substance or drug product with which it is, or may be in direct contact. The closure is a part of the container.

Containers must be chosen with care and after taking into consideration the nature of the articles and the likely effects of transportation and storage, even for short periods of time.

A container should be designed so that the contents may be removed in a manner suitable for the intended use of the article in it. It should also provide an adequate degree of protection, minimise the loss of constituents and should not interact physically or chemically with the contents in a way that will alter their quality to an extent beyond the limits given in the individual monograph, or present a risk of toxicity.

The choice of a container for any article is also governed by the likely period of storage of the article during which its quality will not be compromised to a degree where it will be unfit for use. Under the heading Storage, the pharmacopoeia indicates the measures to be taken to protect the article from contamination and deterioration during its entire shelf-life. Specifications for the container to be used for any article have not been given but in certain cases, the type of container that is recommended is stated in terms that have the following meanings.

*Airtight container.* A container that is impermeable to solids, liquids and gases under ordinary conditions of handling, storage and transport. If the container is intended to be opened on more than once, it must be so designed that it remains airtight after re-closure.

*Hermetically Sealed container.* A container that is impervious to air or any other gas under normal conditions of handling, shipment, storage and distribution, e.g. sealed glass ampoule, gas cylinder etc.

*Light-resistant container.* A container that protects the contents from the effects of actinic light by virtue of the specific properties of the material of which it is made. Alternatively, a clear and colourless or a translucent container may be made light-resistant by means of an opaque (light-resistant) covering and/or stored in a dark place; in such cases, the label on the container should bear a statement that the opaque covering or storage in dark place is needed until the contents have been used up.

*Multidose container.* A container that holds a quantity of the preparation suitable for two or more doses.

*Sealed container.* A container closed by fusion of the material of the container.

*Single-dose container.* A container that holds a quantity of the preparation intended for total or partial use as a single administration.

*Tamper-evident container.* A container fitted with a device or mechanism that reveals irreversibly whether the container has been opened.

*Tightly-closed container.* A tightly-closed container protects the contents from contamination by extraneous liquids, solids or vapours, from loss or deterioration of the article from effervescence, deliquescence or evaporation under normal conditions of handling, shipment, storage and distribution. A tightly-closed container must be capable of being tightly re-closed after use. Where a tightly-closed container is specified, a hermetically sealed container may be used for a single dose of an article. A gas cylinder may be considered to be a metallic, tightly-closed container designed to hold gas under pressure.

*Well-closed container.* A well-closed container protects the contents from extraneous solids and liquids and from loss of the article under normal conditions of handling, shipment, storage and distribution.

## 6.2. Containers for Pharmaceutical Products

This chapter deals with the specific requirements, guidance and information on containers used for packaging pharmaceutical products. The materials that are used in the manufacture of containers, particularly plastic containers, the raw materials and additives used and the formulations employed should be agreed with the users of the containers. Any changes should also be notified to the users from time to time to enable them to ensure the stability and safety of the drugs packed in the containers.

### 6.2.1 Glass Containers

Glass containers may be colourless or coloured.

Neutral glass is a borosilicate glass containing significant amounts of boric oxide, aluminium oxide, alkali and/or alkaline earth oxides. It has a high hydrolytic resistance and a high thermal shock resistance.

Soda-lime-silica glass is a silica glass containing alkali metal oxides, mainly sodium oxide and alkaline earth oxides, mainly calcium oxide. It has only a moderate hydrolytic resistance.

According to their hydrolytic resistance, glass containers are classified as:

- Type I glass containers which are of neutral glass, with a high hydrolytic resistance, suitable for most preparations whether or not for parenteral use,
- Type II glass containers which are usually of soda-lime-silica glass with high hydrolytic resistance resulting from suitable treatment of the surface. They are suitable for most acidic and neutral, aqueous preparations whether or not for parenteral use,
- Type III glass containers which are usually of soda-lime-silica glass with only moderate hydrolytic

resistance. They are generally suitable for non-aqueous preparations for parenteral use, for powders for parenteral use (except for freeze-dried preparations) and for preparations not for parenteral use.

Glass containers intended for parenteral preparations may be ampoules, vials or bottles. The glass used in the manufacture of such containers complies with one of the requirements for hydrolytic resistance given below.

Containers of Type II or Type III glass should be used once only. Containers for human blood and blood components must not be re-used. Glass containers with a hydrolytic resistance higher than that recommended for a particular type of preparation may generally also be used.

Containers for parenteral preparations are made from uncoloured glass except that coloured glass may be used for substances known to be light - sensitive; in such cases, the containers should be sufficiently transparent to permit visual inspection of the contents.

#### Hydrolytic resistance

The tests to be done for defining the type of glass are given in Table 1

Table 1

Type of container	Test to be done
Type I and Type II glass containers to distinguish from Type III glass containers	Test 1 (surface test)
Type I and Type II glass containers where it is necessary to determine whether the high hydrolytic resistance is due to the chemical composition or the surface treatment	Tests 1 and 2

**Test 1.** Carry out the determination on the unused containers. The number of containers to be examined and the volumes of test solution to be used are given in Table 2.

Table 2

Nominal capacity of container (ml)	Number of containers to be used	Volume of test solution to be used for titration (ml)
Up to 3	At least 20	25.0
5 or less	At least 10	50.0
6 to 30	At least 5	50.0
More than 30	At least 3	100.0

Remove any debris or dust from the containers. Rinse each container at least twice with *water* at room temperature. Just before the test rinse each container with freshly prepared *distilled water* and allow to drain. Complete the cleaning

procedure from the first rinsing in not less than 20 minutes and not more than 25 minutes. Fill the containers to the brim with freshly prepared *distilled water*, empty them and determine the average overflow volume.

Heat closed ampoules on a water-bath or in an air-oven at about 50°. Fill the ampoules with freshly prepared *distilled water* to the maximum volume compatible with sealing them by fusion of the glass and seal them. Fill bottles or vials to 90 per cent of their calculated overflow volume and cover them with borosilicate glass dishes or aluminium foil previously rinsed with freshly prepared *distilled water*. Place the containers in an autoclave containing water so that they remain clear of the water. Close the autoclave, displace the air by passage of steam for 10 minutes, raise the temperature from 100° to 121° over 20 minutes, maintain a temperature of 121° for 60 minutes and reduce the temperature from 121° to 100° over 40 minutes, venting to prevent vacuum. Remove the containers from the autoclave and cool them in a bath of running tap water. Carry out the following titration within 1 hour of removing the containers from the autoclave. Combine the liquids from the containers under examination, measure the volume of test solution specified in Table 2 into a conical flask and add 0.15 ml of *methyl red solution* for each 50 ml of liquid. Titrate with 0.01M *hydrochloric acid* taking as the end-point the colour obtained by repeating the operation using the same volume of freshly prepared *distilled water*. The difference between the preparations represents the volume of 0.01M *hydrochloric acid* required by the test solution. Calculate the volume of 0.01M *hydrochloric acid* required for each 100 ml of test solution, if necessary. The result is not greater than the value stated in Table 3.

Table 3

Capacity of container [corresponding to 90 per cent average overflow volume (ml)]	Volume of 0.01M hydrochloric acid per 100 ml of test solution	
	Type I or II glass (ml)	Type III glass (ml)
Not more than 1	2.0	20.0
More than 1 but not more than 2	1.8	17.6
More than 2 but not more than 5	1.3	13.2
More than 5 but not more than 10	1.0	10.2
More than 10 but not more than 20	0.80	8.1
More than 20 but not more than 50	0.60	6.1
More than 50 but not more than 100	0.50	4.8
More than 100 but not more than 200	0.40	3.8
More than 200 but not more than 500	0.30	2.9
More than 500	0.20	2.2



**Test 2.** Examine the number of containers indicated in Table 2. Rinse the containers twice with water and then fill completely with a 4 per cent v/v solution hydrofluoric acid and allow to stand at room temperature for 10 minutes. Empty the containers and rinse carefully five times with water. Carry out the procedure described under Hydrolytic resistance. Compare the results with the limiting values given in Table 3. For Type I glass the values obtained with the hydrofluoric acid-treated containers are closely similar to those stated in the Table for Type I or Type II glass. For Type II glass the values obtained with the hydrofluoric acid-treated containers greatly exceed those given in the Table for Type I or Type II glass and are similar to those given for Type III glass.

**Arsenic.** Glass ampoules should comply with the following test. Carry out the test on ampoules the inner and outer surfaces of which are washed five times with freshly distilled water.

Prepare a test solution as described in the test for Hydrolytic resistance for an adequate number of ampoules to produce 50 ml. Pipette 10 ml of the test solution from the combined contents of all the ampoules into a flask, add 10 ml of *nitric acid* and evaporate to dryness on a water-bath. Dry the residue in an oven at 130° for 30 minutes. Cool, add to the residue 10.0 ml of *hydrazine-molybdate reagent*, swirl to dissolve and heat under reflux on a water-bath for 20 minutes. Cool to room temperature. Determine the absorbance of the resulting solution at the maximum at about 840 nm (2.4.7), using 10.0 ml of *hydrazine-molybdate reagent* as the blank. The absorbance of the test solution does not exceed the absorbance obtained by repeating the determination using 0.1 ml of *arsenic standard solution (10 ppm As)* in place of the test solution (0.1 ppm).

### 6.2.2 Metal Containers for Eye Ointments

Metal collapsible tubes comply with the following test for metal particles.

Select a sample of 50 tubes from the lot to be tested and clean each tube by vibration and/or “blowing”. (A lot may be either the tube manufacturer’s day’s production or a consignment delivered to the tube user). Fill the tubes with a suitable molten eye ointment base, close the open end of each tube by a double fold and allow the filled tubes to cool overnight at a temperature of 15° to 20°.

Assemble a metal bacteriological filter with a 4.25-cm filter paper of suitable porosity supported on suitable perforated plate in place of the standard sintered carbon disc and heat it in a suitable manner to a temperature above the melting range of the base. Remove the caps from the cooled tubes and apply uniform pressure to the closed end of each tube in turn, in such a manner that the time taken to express as much of the base as possible through each nozzle is not less than

20 seconds. Collect the extruded base from the 50 tubes in the heated filter, applying suction to the stem of the filter in order to draw the molten base through the filter paper. When the entire melted base has been removed, wash the walls of the filter and the filter paper with three successive quantities, each of 30ml, of chloroform, allow the filter paper to dry and immediately mount it between glasses for examination.

Examine the filter paper under oblique lighting with the aid of magnifying glass with a graticule of 1 mm squares, one of which is sub-divided into 0.2 mm squares and note (a) the number of all metal particles 1 mm in length and longer, (b) the number in the range 0.5 mm to less than 1 mm and (c) the number in the range 0.2 mm to less than 0.5 mm.

Carry out two further examinations with the filter paper in two different positions so that the lighting comes from different directions and calculate the average number of metal particles counted in each of the three ranges specified. Give each metal particle detected on the filter paper a score as follows and add the scores together.

Particles 1 mm and above	50
Particles 0.5 mm but less than 1 mm	10
Particles 0.2 mm but less than 0.5 mm	2
Particles less than 0.2 mm	Nil

The lot of tubes passes the test if the total score is less than 100 points; if the total score is more than 150 points, the lot fails the test. If the total score is between 100 and 150 (inclusive), the test is repeated on a further sample of 50 tubes and the lot passes the test if the sum of total scores in the two tests is less than 150 points.

### 6.2.3 Plastic Containers and Closures

Plastic containers for pharmaceutical products are made from plastics based on the following polymers: polyethylene (low or high density), polypropylene, polyvinyl chloride, polystyrene and to a lesser extent polyethylene terephthalate. The containers consist of one or more polymers together with certain additives if necessary. They should be manufactured from materials that do not include in their composition any substances that can be extracted by any contents in such quantities so as to alter the efficacy or stability of the product or to present a toxic hazard.

Additives may consist of antioxidants, lubricants, plasticisers and impact modifiers but not antistatic agents and mould-release agents.

The selection of a suitable plastic container should be based on a knowledge, obtained from the supplier of the raw materials used and of the composition of the plastic so that potential hazards can be assessed. The plastic container chosen for any particular product should be such that the ingredients of the product in contact with the plastic material are not

significantly adsorbed on its surface and do not significantly migrate into or through the plastic. Type samples of the intended container should be packed with the product and tested under conditions that reproduce those that would be encountered in use. These tests should include examination of the product to ensure absence of any sensory, chemical or physical change, an assessment of changes in the quantity of contents due to permeability of the plastic, detection of changes in pH, an assessment of the effects of light, chemical tests and where necessary, biological tests. Containers from bulk production should conform to the type sample in every respect. It should be ensured that there is no change in the composition or any change in the manufacturing method used by the manufacturer and more importantly, that no use is made of scrap material. It must be emphasized that changes in the composition of the plastic, reworking or inadequate control of processing can bring about changes which may invalidate the results of type testing. Samples from production should be tested to ensure conformance to type samples and test schedules should be designed to check departures from the characteristic of the type sample.

The biological and chemical tests described below are intended for plastic containers in which pharmaceutical preparations are dispensed. It should be appreciated that these tests by themselves are not sufficient to establish safety or suitability of the plastic containers for the preparations and it is necessary to consider the results of the tests in conjunction with the information given above. Specification should be agreed with the container manufacturer and should be revised if the composition of the plastic or the ingredient quality is altered or the processing treatment is changed.

#### 6.2.3.1 Plastic Containers for Non-parenteral Preparations

**Leakage test.** Fill ten containers with water, fit with the intended closures and keep them inverted at room temperature for 24 hours. There are no signs of leakage from any container.

**Collapsibility test.** This test is applicable to containers which are to be squeezed in order to remove the contents. A container, by collapsing inward during use, yields at least 90 per cent of its nominal contents at the required rate of flow at ambient temperature.

The following tests are applicable to containers intended for filling oral liquids.

**Clarity of aqueous extract.** Select unlabelled, unmarked and non-laminated portions from suitable containers, taken at random, sufficient to yield a total area of sample required, taking into account the surface area of both sides. Cut these portions into strips, none of which has a total area of more than 20 cm<sup>2</sup>. Wash the strips free from extraneous matter by shaking them with at least two separate portions of distilled water for about 30 seconds in each case, then draining off the water thoroughly.

Select cut and washed portions of the sample with a total surface area of 1250 cm<sup>2</sup>, transfer to a flask, previously cleaned with *chromic acid mixture* and rinsed with several portions of *distilled water* and add 250 ml of *distilled water*. Cover the flask with a beaker and autoclave at 121° for 30 minutes. Carry out a blank determination using 250 ml of *distilled water*. Cool and examine the extract; it is colourless and free from turbidity.

**Non-volatile residue.** Evaporate 100 ml of the extract obtained in the test for Clarity of aqueous extract to dryness and dry to constant weight at 105°. The residue weighs not more than 12.5 mg.

#### 6.2.3.2 Plastic Containers for Parenteral Preparations

##### General Requirements

**Material.** Plastic containers for parenteral preparations are manufactured from one or more polymers. The polymers most commonly used are polyethylene, polypropylene and poly(vinyl chloride). Only virgin plastic material, which is practically odourless, is used in the manufacture of the containers. Additives such as antioxidants, lubricants, plasticisers, stabilisers, etc. may be used but no pigment may be used for purposes of colouring. Recycling of excess material of well-defined nature and proportions may be permitted after appropriate validation.

**Characteristics.** The containers may be bags or bottles. They have a site suitable for the attachment of an infusion set designed to ensure a secure connection. They may have a site that allows an injection to be made at the time of use. They usually have a part that allows them to be suspended and which will withstand the tension occurring during use. Although it may not be feasible to include parameters for construction and design of containers in terms of size, shape and weight, for example those meant for large volume parenterals (LVP), of different materials and made on different machines, both manufactured indigenously and internationally, involved in the production of such plastic containers, nevertheless the integrity of neck and shoulders of the containers should be suitably and appropriately strengthened and it shall be the responsibility of such LVP manufacturers to ensure that the containers withstand the stress conditions and rigors of transportation and packaging. The containers must withstand the sterilisation conditions to which they will be submitted. The design of the container and the method of sterilisation chosen are such that all parts of the containers that may be in contact with the infusion are sterilised. The containers are impermeable to micro-organisms after closure. The containers are such that after filling they are resistant to damage from accidental freezing which may occur during transport of the final preparation. The containers are and remain sufficiently transparent to allow the appearance of the contents to be examined at any time, unless otherwise justified and authorised.

The empty containers display no defects that may lead to leakage and the filled and closed container shows no leakage.

For satisfactory storage of some preparations, the container should be enclosed in a protective envelope. The initial evaluation of storage is then to be carried out using the container enclosed in the envelope.

### Tests on Containers

**Leakage test, Collapsibility test.** Comply with the tests described under Plastic Containers for Non-parenteral Preparations.

**Solution S.** Fill a container to its nominal capacity with water and close it, if possible using the usual means of closure; otherwise close using a sheet of pure aluminium. Heat in an autoclave so that a temperature of  $121 \pm 2^\circ$  is reached within 20 to 30 minutes and maintain at this temperature for 30 minutes. If heating at  $121^\circ$  leads to deterioration of the container, heat at  $100^\circ$  for 2 hours.

*Use solution S within 4 hours of preparation.*

**Blank.** Prepare a blank by heating water in a borosilicate-glass flask closed by a sheet of pure aluminium at the temperature and for the time used for the preparation of solution S.

**Clarity and colour of solution S.** Solution S is clear (2.4.1) and is colourless (2.4.1).

**Acidity or alkalinity.** To a volume of solution S corresponding to 4 per cent of the nominal capacity of the container add 0.1 ml of *phenolphthalein solution*. The solution is colourless. Add 0.4 ml of *0.01M sodium hydroxide*. The solution is pink. Add 0.8 ml of *0.01M hydrochloric acid* and 0.1 ml of *methyl red solution*. The solution is orange-red or red.

**Light absorption.** The light absorption in the range 230 nm to 360 nm of solution S using a blank prepared as described under Solution S is not more than 0.20 (2.4.7).

**Reducing substances.** To 20.0 ml of solution S add 1 ml of *dilute sulphuric acid* and 20.0 ml of *0.002M potassium permanganate*. Boil for 3 minutes. Cool immediately. Add 1 g of *potassium iodide* and titrate immediately with *0.01M sodium thiosulphate*, using 0.25 ml of *starch solution* as indicator. Carry out a titration using 20.0 ml of the blank prepared as described under Solution S. The difference between the titration volumes is not more than 1.5 ml.

**Transparency.** Fill the container previously used for the preparation of solution S to its nominal capacity with a 1 in 200 dilution of the standard suspension (2.4.1) for a container made from polyethylene or polypropylene. For containers of other materials, use a 1 in 400 dilution. The cloudiness of the suspension is perceptible when viewed through the container and compared with a similar container filled with water (2.4.1).

**Labelling.** The label accompanying a batch of empty containers states (1) the name and address of the manufacturer; (2) a batch number which enables tracing the history of the container and of the plastic material of which it is manufactured.

### Tests on Container Material

The following tests are done on portions of the container that are unlabelled, unprinted or non-laminated or on the granules of plastic in the case of containers made by the 'form-fill-seal' process.

**Barium.** Moisten 2 g with *hydrochloric acid* and ignite in a platinum dish. Dissolve the residue in 10 ml of *1M hydrochloric acid*, filter and add 1 ml of *1M sulphuric acid* to the filtrate. Any turbidity produced is not greater than that produced on adding 1 ml of *1M sulphuric acid* to a mixture of 10 ml barium standard solution (10 ppm Ba) and 10 ml of *1M hydrochloric acid*.

**Heavy metals.** To 2.5 g in a long-necked round-bottomed flask add 20 ml of *sulphuric acid* and char for about 10 minutes. Add *hydrogen peroxide solution (100 vol)* dropwise to the hot solution until it becomes colourless, heating between each addition until white fumes are evolved. Cool, transfer to a platinum dish with the aid of 10 ml of *water* and evaporate to dryness. Dissolve the residue in 10 ml of *1M hydrochloric acid*, filter if necessary and add sufficient *water* to produce 25 ml (solution A).

To a mixture of 10 ml of solution A and 2 ml of *acetate buffer pH 3.5* add 1.2 ml of *thioacetamide reagent*, mix immediately and allow to stand for 2 minutes. Any yellow colour in the solution is not more intense than the yellow colour obtained by repeating the operation using 10 ml of *cadmium standard solution (10 ppm Cd)* in place of solution A. Any brown colour in the solution is not more intense than that obtained by repeating the operation using a mixture of 5 ml of *lead standard solution (10 ppm Pb)* and 5 ml of *water* in place of solution A.

**Tin.** To 10 ml of solution A obtained in the test for Heavy metals add 5 ml of *sulphuric acid (20 per cent)*, 1 ml of a 1 per cent w/v solution of *sodium dodecyl sulphate* and 1 ml of *zinc dithiol reagent*. Heat in a water-bath for exactly 1 minute, cool and allow to stand for 30 minutes. Any red colour in the solution is not more intense than the red colour obtained by repeating the operation using 10 ml of *tin standard solution (5 ppm Sn)* in place of solution A.

**Zinc.** To 1 ml of solution A obtained in the test for Heavy metals add sufficient *water* to produce 100 ml. To 10 ml of the resulting solution (test solution) add 5 ml of *acetate buffer solution pH 4.4*, 1 ml of *0.1M sodium thiosulphate* and 5 ml of 0.001 per cent w/v solution of *dithizone* in *chloroform*, shake and allow to stand for 2 minutes. Any violet colour in

the chloroform layer is not more intense than that obtained by repeating the operation using a mixture of 2 ml of *zinc standard solution* (10 ppm Zn) and 8 ml of *water* in place of the test solution. Carry out a blank determination using 10 ml of *water* in place of test solution. The test is not valid unless the chloroform layer obtained in the blank determination is colourless.

**Residue on Ignition.** Not more than 0.1 per cent, determination on 5 g of the sub-divided sample in a suitable tared crucible. Ignite to constant weight in a muffle furnace at  $800 \pm 25^\circ$ . Allow the crucible to cool in a desiccator after each ignition.

### Biological Tests

The following tests are designed to determine the biological response of animals to plastics and other polymeric material by the injection or instillation of specific extracts from the material under test.

It is essential to make available the specific area for extraction. When the surface area of the specimen cannot be determined, use 0.2 g of plastic or other material for every ml of extraction fluid. It is also essential to exercise care in the preparation of the materials to be injected or instilled to prevent contamination with micro-organisms and other foreign matter.

The tests are designed for application to plastics and other polymers in the condition in which they are used. If the material is to be subjected to any cleaning or sterilising process prior to its end use, than the tests are to be conducted on a sample prepared from a specimen preconditioned by the same processing.

A sample is defined as the specimen under test or an extract prepared from such a specimen. A blank consists of the same quantity of the same extracting medium that is used for the extraction of the specimen under test, treated in the same manner as the extracting medium containing the specimen under test. A negative control is a specimen that gives no reaction under the conditions of the test.

**Systemic Injection test.** This test is designed to evaluate systemic responses to the extracts of materials under test following injection into mice.

**Test animals.** Use healthy, not previously used albino mice weighing between 17 and 23 g for each test group use only mice of the same source. Allow water and food ad libitum.

**Apparatus.** The apparatus for the tests includes the following:

**Autoclave.** Use an autoclave capable of maintaining a temperature of  $121 \pm 2^\circ$ , equipped with a water cooling system that will allow to cooling of the test containers to about  $20^\circ$ , but not below, immediately following the heating cycle.

**Oven.** Use an oven, preferably a forced- circulation model, that will maintain operating temperatures of  $50^\circ$  or  $70^\circ \pm 2^\circ$ .

**Extraction containers.** Use containers such as ampoules or screw-capped culture test-tubes, of Type I glass. If used, culture test-tubes are closed with screw caps having suitable elastomeric liners. The exposed surface of the liner is completely protected with an inert solid disc 0.05 mm to 0.075 mm in thickness. A suitable disc may be fabricated from a PTFE resin.

**Preparation of apparatus.** Clean all glassware thoroughly with *chromic acid mixture*, or if necessary with hot *nitric acid*, followed by prolonged rinsing with *water*. Clean cutting devices by an appropriate method (e.g. successive cleaning with *acetone* and *dichloromethane*) prior to use in subdividing a specimen.

Clean all other equipment by thorough scrubbing with a suitable detergent and prolonged rinsing with *water*. Render containers and equipment used for extraction, and in transfer and administration of test material, sterile and dry by a suitable process.

**Extracting media.** (a) *Sodium Chloride Injection* – A sterile and pyrogen-free 0.9 per cent w/v solution of sodium chloride in water for injections.

Table 4

Form of plastic	Thickness	Amount of sample for each 20 ml of extracting medium	Subdivided into
Film or sheet	Less than 0.5 mm	Equivalent of 120 cm <sup>2</sup> total surface area (both sides combined)	Strips of about 5 x 0.3 cm
	0.5 to 1 mm	Equivalent of 60 cm <sup>2</sup> total surface area (both sides combined)	
Tubing	Less than 0.5 mm (wall)	Length (in cm) = 120 cm <sup>2</sup> / (sum of ID and OD circumferences)	Sections of about 5 x 0.3 cm
	0.5 to 1 mm (wall)	Length (in cm) = 60 cm <sup>2</sup> / (sum of ID and OD circumferences)	
Slabs, tubing and moulded items	More than 1 mm	Equivalent of 60 cm <sup>2</sup> total surface area (all exposed surfaces combined)	Pieces up to about 5 x 0.3 cm



(b) A 5 per cent v/v solution of *ethanol* in sodium *chloride* injection.

(c) *Polyethylene Glycol 400*

(d) *Vegetable Oil*. Use freshly refined sesame oil or cottonseed oil or arachis oil that meets the following additional requirement. Using three test animals prepared as directed under the test for Intracutaneous Test, inject 0.2 ml intracutaneously at each of 10 sites on each animal and examine the injected sites 24, 48 and 72 hours after injection. No site shows a greater reaction, oedema or erythema than 0.5 cm in diameter.

**Preparation of Sample.** Select and subdivide into portions a sample of the size indicated in Table 4. Remove particulate matter such as lint and free particles, by treating each subdivided sample as follows.

Place in a clean, glass-stoppered, 100-ml graduated cylinder of Type I glass and add about 70 ml of *water for injections*. Agitate for about 30 seconds, and drain off the water, repeat this step, and dry those piece prepared for the extraction with vegetable oil in an oven at a temperature not exceeding 50°.

**NOTES** – 1. Do not clean the sample with a dry or wet cloth or by rinsing with an organic solvent, surfactant etc.

2. When surface area cannot be determined due to the configuration of the specimen, use 0.2 g of the plastic or other polymer of the plastic or other polymer for every 1 ml of the extracting medium.

**Preparation of extracts.** Place a properly prepared sample to be tested in an extraction container and add 20 ml of the appropriate extraction medium. Repeat these directions for each extracting medium required for testing. Also prepare one 20-ml blank of each medium for parallel injections and comparisons. Extract by heating in an autoclave at 121° for 60 minutes, in an oven at 70° for 24 hours, or at 50° for 72 hours, depending upon the kind of plastic under examination. Allow adequate time for the liquid within the container to reach the extraction temperature.

Cool to about room temperature but not below 20°, shake vigorously for several minutes and decant each extract immediately, using aseptic precautions, into a dry, sterile vessel. Store the extracts at a temperature between 20° and 30°, and do not use for tests after 24 hours.

**NOTE** – The extraction conditions should not in any instance cause physical changes such as fusion or melting of the sample pieces which result in a decrease in the available surface area. A slight adherence of the pieces may be acceptable. Always add the cleaned pieces individually to the extracting medium. If culture tubes are used for autoclave extractions with vegetable oil, seal the screw caps adequately with pressure-sensitive tape.

**Procedure.** Agitate each extract vigorously prior to withdrawal of injection doses to ensure even distribution of the extracted matter. However, visible particles should not be injected intravenously. Inject each of the five mice in a test group with the sample or the blank as outlined in Table 5, except to dilute each g of the extract of the sample prepared with polyethylene glycol 400 and the corresponding blank with 4.1 volumes of sodium chloride injection to obtain a solution having a concentration of about 200 mg of polyethylene glycol per ml.

Observe the animals immediately after injection, again 4 hours after injection, and then at least at 24, 48 and 72 hours. If during the observation period none of the animals treated with the extract shows a significantly greater biological reactivity than the animals treated with the blank, the sample meets the requirements of this test. If two or more mice die, or if abnormal behaviour such as convulsions or prostration occurs in two or more mice, or if a body weight loss greater than 2 g occurs in three or more mice, the sample does not meet the requirements of the test. If any animals treated with the sample show only slight signs of biological reactivity and not more than one animal shows gross symptoms of biological reactivity or dies, repeat the test using groups of 10 mice. On the repeat test, all 10 animals treated with the sample show no significant biological reactivity above the animals tested with the blank during the observation period.

Table 5

Extract or Blank	Dose	Route*	Injection rate per kg µl per sec
Sodium Chloride injection	50ml	IV	100
5 per cent v/v solution of Ethanol in Sodium Chloride Injection	50ml	IV	100
Polyethylene Glycol 400	10 g	IP	
Vegetable Oil	50ml	IP	

\*IV = intravenous (aqueous sample and blank); IP = intraperitoneal (oleaginous sample and blank)

**Intracutaneous test.** This test is designed to evaluate local response to the extracts of materials being examined following intracutaneous injection into rabbits.

**Test animals.** Select healthy, thin-skinned albino rabbits whose fur can be clipped closely and whose skin is free from mechanical irritation or trauma. In handling the animals, avoid touching the injection sites during observation periods, except to discriminate between edema and an oil residue.

**NOTE** – Rabbits previously used in unrelated tests, such as the test for pyrogens, and that have received the prescribed rest period, may be used for this test provided they have clean, unblemished skin.

**Procedure.** On the day of the test, closely clip the fur on the animal's back on both side of the spinal column over a sufficiently large test area. Avoid mechanical irritation and trauma. Remove loose hair by means of vacuum. If necessary, swab the skin lightly with diluted *ethanol*, and dry the skin prior to injection. More than one extract from a given material can be used per rabbit if it has been determined that the results will not be affected. For each sample use two animals and inject each intracutaneously, using one side of the animal for the sample and the other side for the blank, as outlined in Table 6

Table 6

Extract or blank	Number of sites (per animal)	Dose per site ( $\mu$ l)
Sample	5	200
Blank	5	20

Agitate each extract vigorously prior to withdrawal of injection doses to ensure even distribution of the extracted matter. Dilute each g of the extract of the sample prepared with *polyethylene glycol 400* and the corresponding blank with 7.4 volumes of *sodium chloride injection* to obtain a solution having a concentration of about 120 mg of polyethylene glycol per ml.

Examine injection sites for evidence of any tissue reaction such as erythema, oedema and necrosis. Swab the skin lightly, if necessary, with diluted ethanol to facilitate reading of injection sites. Observe all animals at 24, 48 and 72 hours after injection. Rate the observations on a numerical scale for the extract of the sample and for the blank, using Table 7.

Table 7

Erythema And eschar Formation	Score
No erythema	0
Very slight erythema (barely perceptible)	1
Well-defined erythema	2
Moderate to severe erythema	3
Severe erythema (redness) to slight eschar formation (injuries in depth)	4
Oedema formation *	Scores
No oedema	0
Very slight oedema (barely perceptible)	1
Slight oedema ( edges or are well defined by definite raising)	2
Moderate oedema (raised approximately 1 mm)	3
Severe oedema (raised more than 1 mm and extending beyond the area of exposure)	4

\*Exclude non-inflammatory oedema from the blank or extraction fluid.

Reclip the fur as necessary during the observation period. The average erythema and oedema scores for sample and blank sites are determined at every scoring interval (24, 48 and 72 hours) for each rabbit. After the 72 hours scoring, all erythema scores plus edema score are totalled separately for each sample and blank.

Divide each of the totals by 12 (2 animals x 3 scoring periods x 2 scoring categories) to determine the overall mean score for each sample versus each corresponding blank. The requirements of the test are met if the difference between the sample and the blank mean score is 1.0 or less. If at any observation period the average reaction to the sample is questionably greater than the average reaction to the blank, repeat the test using three additional rabbits. The requirements of the test are met if the difference between the sample and the blank mean score is 1.0 or less.

### 6.2.3.3 Plastic Containers for Ophthalmic Preparations

Plastic containers for ophthalmic preparations are made from plastic composed of a mixture of homologous compounds having a range of molecular weights. Such plastics frequently contain other substances such as residues from the polymerisation process, plasticisers, stabilisers, antioxidants, lubricants and pigments. For deciding the suitability of a plastic for use as a container for ophthalmic preparations, factors such as the composition of the plastic, processing and cleaning procedures, contacting media, adhesives, adsorption and permeability of preservatives, conditions of storage, etc. should be evaluated by appropriate additional specific tests.

Plastic containers for ophthalmic preparations comply with the following tests.

#### Leakage test; Collapsibility test; Clarity of aqueous extract; Non-volatile residue.

Comply with the tests described under Plastic containers for Non-parenteral Preparations.

**Systemic injection test; Intracutaneous test.** Comply with the tests described under Plastic containers for Parenteral Preparations.

**Eye irritation test.** This test is designed to evaluate responses to the instillation of extracts of material under examination in the eye of a rabbit.

#### Extracting Media – (a) Sodium Chloride Injection (b) Vegetable Oil

**Test animals.** Select healthy, albino rabbits having no visible eye irritation and not previously used for an eye irritation test. The animal house should be designed and maintained so as to exclude sawdust, wood chips, or other extraneous materials that might produce eye irritation. Examine both eyes of the animals before testing and use only those animals without eye defects or eye irritations.

To test the suitability of the rabbit ocular system in use for a given set of samples, select one test animal and proceed as shown under procedure using 100 µl of a blank prepared as directed under Systemic injection test in one eye and 100 µl of sterile water for injection in the other eye. The rabbit ocular system is suitable if no significant differences are found between the two eyes.

**Procedure.** Use three albino rabbits for each extract to be examined. Restrain the animals firmly but gently until quiet. Gently pull and lower lid away from the eyeball to form a cup, and instil about 100 µl of *sterile water for injection*. Hold the lid together for about 30 seconds. Instil into the other eye 100 µl of the sample extract prepared as directed under Systemic injection test. Examine the eyes 24, 48 and 72 hours after instillation. The requirements of the test are met if the sample extract shows no significant irritant response during the observation period over that with the blank extract and the rabbit ocular system is suitable. If irritation is observed in the control eye treated with *sterile water for injection* or if the rabbit ocular system is shown not to be suitable, repeat the test using three additional rabbits. On the repeat test, all the rabbits meet the test requirement.

### 6.3. Closures for Containers of Parenteral Products

A closure for a container for an aqueous parenteral preparation or for a sterile powder is a packaging component which is in direct contact with the drug. A rubber closure is made of materials obtained by vulcanisation (cross-linking) of elastomers with appropriate additives. The elastomers are produced from natural or synthetic substances by polymerisation, polyaddition or polycondensation. The nature of the principal components and of the various additives such as vulcanisers, accelerators, stabilising agents, pigments, etc. depends on the properties required for the finished closure. The requirements of this chapter do not apply to closures made from silicone elastomer, to laminated closures or to lacquered closures.

Rubber closures are used in a number of formulations and consequently different closures possess different properties. The closures chosen for use with a particular preparation should be such that the components of the preparation in contact with the closure are not adsorbed onto the surface of the closure to an extent sufficient to affect the product adversely. The closure should not yield to the product substances in quantities sufficient to affect its stability or to present a risk of toxicity. The closures should be compatible with the preparation for which they are used throughout the shelf-life of the product.

It is impracticable to devise a set of standards which, if complied with, will ensure the compatibility of any closure

with the preparation for which it is to be used. A compatibility test has, therefore, to be carried out before a rubber mix is approved. The user of the closures must obtain an assurance from the supplier that the composition of the closure does not vary from supply to supply and that it is identical to that of the closure used during compatibility testing. When the user is informed of changes in the composition, compatibility testing must be repeated, totally or partly depending on the nature of the changes.

The following test procedures apply to rubber closures which comprise wads (flat rubber discs), plugs (with or without skirt or flange) and caps (rubber covers held in position on the outsides of the containers by the tension of the rubber) so as to form with their appropriate seals an effective barrier against micro-organisms after sterilisation.

Identification of the type of rubber used for closures is not covered in the following tests. The tests given distinguish elastomer and non-elastomer closures but do not differentiate the various types of rubber.

**Description.** Rubber closures are elastic and either translucent or opaque; the colour depends on the additives used. They are homogeneous and practically free from flash and adventitious materials such as fibres, foreign particles and adhering rubber pieces.

#### Identification

A. Heat 1 g to 2 g in a heat-resistant test-tube over an open flame to dry the sample and continue heating until the vapours formed are condensed near the top edge of the test-tube. Deposit a few drops of the condensate on a potassium bromide disc and examine by infrared absorption spectrophotometry (2.4.6), comparing with the spectrum obtained with the type (standard) sample.

B. The total ash (2.3.19) is within  $\pm 10$  per cent of the value obtained with the type sample.

**Preparation of samples.** Wash the closures by agitation in a 0.2 per cent w/v solution of an anionic surface-active agent for 5 minutes at room temperature. Rinse five times with water, place a number of the washed closures corresponding to a surface area of about 100 cm<sup>2</sup>, in a suitable container of borosilicate glass or inert material, add 200 ml of water per 100 cm<sup>2</sup>, surface area of the closures and weigh. Cover the mouth of the container with aluminium foil or a borosilicate glass beaker and heat in an autoclave so that a temperature of 119° to 123° is reached within 20 to 30 minutes and maintain at that temperature for 30 minutes. Cool to room temperature over about 30 minutes and make up to the original weight with *water for injection*. Shake and immediately separate the solution from the closures by decantation (Solution A).

Prepare a blank in the same manner using 200 ml of *water for injection*.

Dry the treated closures at 64° to 66° at a pressure not exceeding 0.7 kPa for 24 hours.

**Appearance of solution.** Solution A is not more opalescent than opalescence standard OS3 (2.4.1), and not more intensely coloured than reference solution BYS6 (2.4.1).

**pH of aqueous extract.** To 20 ml of solution A add 0.1 ml of *bromothymol blue solution*. Not more than 0.3 ml of 0.01M *sodium hydroxide* or 0.8 ml of 0.01M *hydrochloric acid* is required to change the colour of the solution to blue or yellow respectively.

**Light absorption.** Carry out the test within 4 hours of preparing solution A. Filter solution A through a membrane filter with a nominal pore size of 0.5 µm and reject the first few ml of the filtrate. Measure the light absorption of the filtrate in the range 220 to 360 nm (2.4.7), using as the blank a solution prepared in the same manner as solution A but using 200 ml of *water* without the closures. The absorbance is not more than 2.0; if necessary, dilute the filtrate before measurement and correct the results for the dilution.

**Reducing substances.** Carry out the test within 4 hours of preparing solution A. To 20 ml of solution A, add 1 ml of 1M *sulphuric acid* and 20 ml of 0.002 M *potassium permanganate* and boil for 3 minutes. Cool, add 1g of *potassium iodide* and titrate immediately with 0.01 M *sodium thiosulphate* using 0.25 ml of *starch solution*, added towards the end of the titration, as indicator. Repeat the operation using 20 ml of the blank prepared in the test for Light absorption. The difference between the titration volumes is not more than 7.0 ml.

**Heavy Metals** (2.3.13). 20 ml of solution A complies with the limit test for heavy metals, Method A.

**Residue on evaporation:** Evaporate 50 ml of solution A to dryness on a water-bath and dry at 105°. The residue weighs not more than 4.0 mg.

**Volatile sulphides.** Place closures, cut if necessary, with a total surface area of  $20 \pm 2$  cm<sup>2</sup> in a 100-ml conical flask and add 50 ml of a 2 per cent w/v solution of *citric acid*. Place a piece of *lead acetate paper* over the mouth of the flask and maintain the paper in position by placing over it an inverted weighing bottle. Heat in an autoclave at  $121 \pm 2^\circ$  for 30 minutes. Any black stain on the paper is not more intense than that of a standard prepared at the same time in the same manner using 0.154 mg of *sodium sulphide* and 50 ml of a 2 per cent w/v solution of *citric acid*.

**Sterilisation test.** The closures 'prepared' in the aforementioned manner shall not soften or become tacky and there shall be no visual change in the closure.

**Fragmentation test.** This test is applicable to closures intended to be pierced by a hypodermic needle. For closures that are intended to be used for aqueous preparations, place a volume of water corresponding to the nominal volume minus 4 ml in

each of 12 clean vials, close the vials with the 'prepared' closures, secure with a cap and allow to stand for 16 hours. For closures that are intended to be used for dry preparations, close 12 clean vials with the 'prepared' closures. Using a lubricated, long-bevel (bevel angle of 10° to 14°) hypodermic needle with an external diameter of 0.8 mm (21 SWG) fitted to a clean syringe, inject 1 ml of water into the vial and remove 1 ml of air; carry out this operation 4 times for each closure, piercing each time at a different site. Use a new needle for each closure and check that the needle is not blunted during the test. Pass the liquid in the vials through a filter with a nominal pore size of 0.5 µm. Count the number of fragments visible to the naked eye. The total number of fragments is not more than 10 except in the case of butyl rubber closures where the total number of fragments is not more than 15.

**Self-sealability.** This test is applicable to closures intended to be used with multidose containers. Fill 10 suitable vials with water to the nominal volume, close the vials with the 'prepared' closures and secure with a cap. For each closure, use a new hypodermic needle with an external diameter of 0.8 mm (21 SWG) and pierce the closure 10 times, piercing each time at a different site. Immerse the vials upright in a 0.1 per cent w/v solution of *methylene blue* and reduce the external pressure by 27kPa for 10 minutes. Restore the atmospheric pressure and leave the vials immersed for 30 minutes. Rinse the outside of the vials. None of the vials contains any trace of coloured solution.

### Biological Tests

The following tests may be done when the compatibility test is done for approving a rubber mix for the manufacture of closures and whenever the composition of the rubber mix is altered. The tests are designed to evaluate the biological response in test animals of an extract of the closures. The contact of the extracting medium with the total surface of the closures, the time and temperature during extraction and the aseptic handling and storage of the extract are important. Particular care must be exercised in the preparation of the extract to be injected to prevent contamination with micro-organisms and foreign matter.

**Extraction containers.** Use only containers such as screw-capped culture test-tubes or bottles, of Type I glass. Screw caps should have suitable elastomeric liners and the exposed surface of the liner should be completely protected with an inert solid disc, 50 to 75 µm in thickness, and fabricated from a material such as teflon or any other polytetrafluoroethylene resin.

All glassware should be thoroughly rinsed with chromic acid mixture, followed by prolonged rinsing with sterile water for injection. Containers and devices used for extraction, transfer of administration of test material should be sterile and dried by a suitable process.



**Procedure.** Place a selected number of intact closures in an extraction container, add 50 ml of sterile *water for injection*, cap and agitate for 2 to 3 minutes. Decant using a stainless steel screen to hold the closures in the container. Repeat this step. Remove the caps, place the containers with the sample and caps in an oven at a temperature of about 50° and allow to dry for not more than 16 hours.

Place two properly prepared samples to be tested in separate extraction containers and add to each containers 1 ml per 1.25 ± 0.1 cm<sup>2</sup>, of sterile *normal saline solution* and extract by heating in an autoclave at 121° ± 0.1° for 60 minutes. Allow adequate time for the liquid within the container to reach the room temperature but not below 20°. Agitate vigorously for several minutes and then aseptically transfer the extract immediately to dry, sterile containers. Carry out the following tests, including a blank test omitting the closures, within 24 hours.

**Test A.** Agitate each extract vigorously prior to withdrawal of injection doses to ensure even distribution of the extracted matter. However, visible particulate matter should not be injected intravenously.

Inject intravenously 1.0 ml of each of the sample extract and the blank solution into each of five healthy albino mice weighing between 17 g and 22 g. The mice should not have been used previously. Observe the animals immediately after injection and then at least at 24, 48 and 72 hours. If during this period none of the animals treated with the sample extracts shows significantly greater reaction than the animals treated with the blank solution, the sample passes the test. If any animal treated with the sample extracts shows only slight signs of toxicity, and not more than one animal shows gross symptoms of toxicity or death, repeat the test using ten mice for each extracts. On the repeat test, all the ten animals treated with the sample extracts show no significant reaction greater than that seen in the animals treated with the blank.

**Test B.** Agitate each extract vigorously prior to withdrawal of injection doses to ensure even distribution of the extracted matter.

Select healthy, thin-skinned albino rabbits whose fur can be closely clipped and whose skin is free from mechanical irritation or trauma. Rabbits previously used in unrelated tests, such as the test for pyrogens, and that have received the prescribed rest period, may be used provided they have clean, unblemished skin. In handling the animals, avoid touching the injection sites when the animals are observed. Use two animals for each extract and inject into five sites of each animal. Inject into each animal intracutaneously 200µl of the sample extract and the blank, using one side of the animal for the sample extract and the other for the blank.

On the day of the test, closely clip the fur on the animal's back on both sides of the spinal column over a sufficiently large

test area. Avoid mechanical irritation and trauma. Remove loose hair by means of vacuum. If necessary, swab the skin lightly with diluted ethanol, and dry the skin prior to injection. Observe the animals at 24, 48 and 72 hours after injection. During these periods examine the injection sites for evidence of any tissue reaction such as erythema, oedema and necrosis.

If each animal at any observation period shows a reaction to the sample extract that is not significantly greater than that to the blank, the sample meets the requirements of the test. If during any observation period the reaction to the sample extract is questionably greater than that to the blank, repeat the test using three additional rabbits. On the repeat test, the reaction to the sample extract in any of the three animals is not significantly greater than that to the blank.

## 6.4 Containers for Blood and Blood Components

### 6.4.1 Sterile Plastic Containers for Blood and Blood Components

Plastic containers for the collection, storage, processing and administration of blood and its components are manufactured from one or more polymers, if necessary with additives. The composition and the conditions of manufacture of the containers are approved/registered by the appropriate competent authorities in accordance with the relevant national legislation and international agreements.

When the composition of the materials of the different parts of the containers corresponds to the appropriate specifications, their quality is controlled by the methods indicated in the specifications, described under Plastic Containers for Parenteral Preparations (6.2.3.2).

Materials other than those described in the Pharmacopoeia may be used provided that their composition is authorised by the Licensing Authority and that the containers manufactured from them comply with the requirements prescribed for Sterile Plastic Containers for Human Blood and Blood Components.

In normal conditions of use the materials do not release monomers, or other substances, in amounts likely to be harmful and do not lead to any abnormal modifications of the blood.

The containers may contain anticoagulant solutions, depending on their intended use, and are supplied sterile.

Each container is fitted with attachments suitable for the intended use. The container may be in the form of a single unit or the collecting container may be connected by one or more tubes to one or more secondary containers to allow separation of the blood components to be effected within a closed system.

The outlets are of a shape and size allowing for adequate connection of the container with the blood-giving equipment.

The protective coverings on the blood-taking needle and on the appendages should be such as to ensure the maintenance of sterility. They should be easily removable but should be tamper-proof.

The capacity of the containers is related to the nominal capacity prescribed by the national authorities and to the appropriate volume of anticoagulant solution. The nominal capacity is the volume of blood to be collected in the container. The containers are of a shape such that when filled they may be centrifuged.

The containers are fitted with a suitable device for suspending or fixing which does not hinder the collection, storage, processing or administration of the blood.

The containers are enclosed in sealed, protective envelopes.

**Description.** The container is sufficiently transparent to allow adequate visual examination of its contents before and after the taking of the blood and is sufficiently flexible to offer minimum resistance during filling and emptying under normal conditions of use. The container contains not more than 5 ml of air.

#### Tests

**Solution S<sub>1</sub>.** Fill the container with 100 ml of sodium chloride injection. Close the container and heat it in an autoclave so that the contents are maintained at 110° for 30 minutes.

If the container under examination contains an anticoagulant solution, first empty it, rinse the container with 250 ml of *water for injections* at 20 ± 1° and discard the rinsings.

**Solution S<sub>2</sub>.** Introduce into the container a volume of water for injections corresponding to the intended volume of anticoagulant solution. Close the container and heat it in an autoclave so that the contents are maintained at 110° for 30 minutes. After cooling, add sufficient water for injections to fill the container to its nominal capacity.

If the container under examination contains an anticoagulant solution, first empty it and rinse it as indicated above.

**Resistance to centrifugation.** Introduce into the container a volume of *water*, acidified by the addition of 1 ml of *dilute hydrochloric acid*, sufficient to fill it to its nominal capacity. Envelop the container with absorbent paper impregnated with a 1 in 5 dilution of *bromophenol blue* reagent or other suitable indicator and then dried. Centrifuge at 5000 g for 10 minutes. No leakage is perceptible on the indicator paper and no permanent distortion occurs.

**Resistance to stretch.** Introduce into the container a volume of *water*, acidified by the addition of 1 ml of *dilute hydrochloric acid*, sufficient to fill it to its nominal capacity. Suspend the container by the suspending device at the opposite end from the blood-taking tube and apply along the axis of this tube an

immediate force of 20N (2.05 kgf). Maintain the traction for 5 seconds. Repeat the test with the force applied to each of the parts for filling and emptying. No break and no deterioration occur.

**Leakage.** Place the container that has been submitted to the stretch test between two plates covered with absorbent paper impregnated with a 1 in 5 dilution of *bromophenol blue* reagent or other suitable indicator and then dried. Progressively apply force to the plates to press the container so that its internal pressure (i.e. the difference between the applied pressure and atmospheric pressure) reaches 67 kPa within 1 minute. Maintain the pressure for 10 minutes. No signs of leakage are detectable on the indicator paper or at any point of attachment (seals, joints, etc.).

**Vapour permeability:** For a container containing an anticoagulant solution, fill with a volume of *sodium chloride injection* equal to the volume of blood for which the container is intended.

For an empty container, fill with the same mixture of anticoagulant solution and *sodium chloride injection*. Close the container, weigh it and store it at 5 ± 1° in an atmosphere with a relative humidity of 50 ± 5 per cent for 21 days. At the end of this period the loss in weight is not more than 1 per cent.

**Emptying under pressure.** Fill the container with a volume of water at 5 ± 1° equal to the nominal capacity. Attach a transfusion set without an intravenous cannula to one of the connectors. Compress the container so as to maintain throughout the emptying an internal pressure (i.e. the difference between the applied pressure and atmospheric pressure) of 40 kPa. The container empties in less than 2 minutes.

**Speed of filling.** Attach the container by means of the blood-taking tube fitted with the needle to a reservoir containing a suitable solution having a viscosity equal to that of blood, such as a 33.5 per cent w/v solution of *sucrose* at 37°. Maintain the internal pressure of the reservoir (i.e. the difference between the applied pressure and atmospheric pressure) at 9.3 kPa with the base of the reservoir and the upper part of the container at the same level. The volume of liquid which flows into the container in 8 minutes is not less than the nominal capacity of the container.

**Resistance to temperature variations.** Place the container in a suitable chamber having an initial temperature of 20° to 23°. Cool it rapidly in a deep-freeze to -80° and maintain it at this temperature for 24 hours. Raise the temperature to 50° and maintain for 12 hours. Allow to cool to room temperature. The container complies with the tests for Resistance to centrifugation, Resistance to stretch, Leakage, Vapour permeability, Emptying under pressure and Speed of filling described above.

**Transparency.** Fill the empty container with a volume equal to its nominal capacity of the standard suspension (2.4.1), diluted so as to have an absorbance at 640 nm of 0.37 to 0.43 (dilution factor about 1 in 16) (2.4.7). The cloudiness of the suspension must be perceptible when viewed through the bag, as compared with a similar container filled with water.

**Extractable matter.** Tests are carried out by methods designed to simulate as far as possible the conditions of contact between the container and its contents which occur in conditions of use.

The conditions of contact and the tests to be carried out on the eluates are described, according to the nature of the constituent materials, in the particular requirements for each type of container.

#### Haemolytic effects in buffered systems

**Stock buffer solution.** Dissolve 90.0 g of sodium chloride, 34.6 g of sodium phosphate and 2.43 g of sodium dihydrogen phosphate dihydrate in water and dilute to 1000 ml with the same solvent. Prepare three buffer solutions as follows

**Buffer solution A<sub>0</sub>.** To 30.0 ml of stock buffer solution add 10.0 ml of *water*.

**Buffer solution B<sub>0</sub>.** To 30.0 ml of stock buffer solution add 20.0 ml of *water*.

**Buffer solution C<sub>0</sub>.** To 15.0 ml of stock buffer solution add 85.0 ml of *water*.

Introduce 1.4 ml of solution S<sub>2</sub> into each of three centrifuge tubes. To tube I add 0.1 ml of buffer solution A<sub>0</sub>, to tube II add 0.1 ml of buffer solution B<sub>0</sub> and to tube III add 0.1 ml of buffer solution C<sub>0</sub>. To each tube add 0.02 ml of fresh, heparinised human blood, mix well and warm on a water-bath at 30 ± 1° for 40 min. Use blood collected less than 3 hours previously or blood collected into either an anticoagulant citrate phosphate dextrose solution (CPD solution) or anticoagulant citrate phosphate dextrose adenine solution (CPDA solution) less than 24 hours previously.

Prepare further three solutions as follows:

3.0 ml of buffer solution A<sub>0</sub> and 12.0 ml of *water* (solution A<sub>1</sub>),

4.0 ml of buffer solution B<sub>0</sub> and 11.0 ml of *water* (solution B<sub>1</sub>),

4.75 ml of buffer solution B<sub>0</sub> and 10.25 ml of *water* (solution C<sub>1</sub>),

To tubes I, II and III add, respectively, 1.5 ml of solution A<sub>1</sub>, 1.5 ml of solution B<sub>1</sub> and 1.5 ml of solution C<sub>1</sub>. At the same time and in the same manner, prepare three other tubes, replacing solution S<sub>2</sub> by *water*. Centrifuge simultaneously the tubes to be examined and the control tubes at exactly 2500 g in the same horizontal centrifuge for 5 minutes. After centrifuging, measure the absorbances of the liquids at about 540 nm (2.4.7), using the stock buffer solution as blank. Calculate the

haemolytic value as a percentage from the expression

$$\frac{A_{exp}}{A_{100}} \times 100$$

where, A<sub>100</sub> = absorbance of tube III,

A<sub>exp</sub> = absorbance of tube I or II or of the corresponding control tubes.

The solution in tube I gives a haemolytic value not greater than 10 per cent and the haemolytic value of the solution in tube II does not differ by more than 10 per cent from that of the corresponding control tube.

**Sterility.** Introduce aseptically into the container 100 ml of *sodium chloride injection* and shake the container to ensure that the internal surfaces have been entirely wetted. Filter the contents of the container through a membrane filter. Complete the test as described under Method of Test for aqueous solutions (2.2.11), paragraph 2, beginning at the words 'After filtration, .....'

**Pyrogens.** Solution S<sub>1</sub> complies with the test for pyrogens (2.2.8). Inject 10 ml of the solution per kilogram of the rabbit's weight.

**Abnormal toxicity.** Solution S<sub>1</sub> complies with the test for abnormal toxicity (2.2.1). Inject 0.5 ml of the solution into each mouse.

**Packaging.** Sterile plastic containers for human blood and blood components are packed in protective tamper-evident envelopes. On removal from its protective envelope the container shows no leakage and no growth of micro-organisms. The protective envelope is sufficiently robust to withstand normal handling.

The protective envelope is sealed in such a manner that it cannot be opened and re-closed without leaving visible traces that the seal has been broken.

**Labelling.** The label states (1) the date after which the container is not intended to be used; (2) that once withdrawn from its protective envelope, the container must be used within 10 days.

A part of the label is reserved for the information required concerning the blood or blood components for which the container is intended to be used.

The ink, or other substance used to print the labels or the writing must not diffuse into the plastic material of the container and must remain legible up to the time of use.

#### 6.4.2 Empty Sterile Containers of Plasticised Poly(vinyl chloride) for Blood and Blood Components

Empty sterile containers of plasticised poly(vinyl chloride) for blood and blood components should meet the requirements

described under the introductory part of section 6.2.3 of chapter 6.2. They also comply with the tests described under sterile plastic containers for blood and blood components and with the following additional tests.

**Acidity or alkalinity.** Introduce into the container a volume of *water for injections* corresponding to the intended volume of anticoagulant solution. Close the container and heat in an autoclave so that the contents are maintained at 110° for 30 minutes. Cool and add sufficient *water for injections* to fill the container to its nominal capacity (solution A). To a volume of solution A corresponding to 4 per cent of the nominal capacity of the container add 0.1 ml of *phenolphthalein solution*; the solution remains colourless. Add 0.4 ml of 0.1M *sodium hydroxide*; the solution is pink. Add 0.8 ml of 0.01M *hydrochloric acid* and 0.1 ml of *methyl red solution*; the solution is orange-red or red.

**Light absorption.** Heat *water for injections* in a borosilicate-glass flask in an autoclave at 110° for 30 minutes (solution B). Measure the light absorption of solution A in the range 230 nm to 360 nm using solution B as blank. The absorbance is not more than 0.30 at any wavelength from 230 nm to 250 nm and not more than 0.10 at any wavelength from 251 nm to 360 nm (2.4.7).

**Ammonium.** Dilute 5 ml of solution A to 14 ml with *water* in a test-tube, if necessary make alkaline with 2M *sodium hydroxide* and dilute further to 15 ml with *water*. Add 0.3 ml of *alkaline potassium mercuri-iodide solution*, stopper the tube, mix and allow to stand for 5 minutes. When viewed vertically, any yellow colour produced is not more intense than that obtained by treating a mixture of 10 ml of *ammonium standard solution* (1 ppm NH<sub>4</sub>) and 5 ml of *water* in the same manner (2 ppm).

**Chlorides.** 15 ml of solution A complies with the limit test for chlorides (2.3.12). Prepare the standard using a mixture of 1.2 ml of *chloride standard solution* (5 ppm Cl) and 13.8 ml of *water* (0.4 ppm).

#### Extractable di(2-ethylhexyl)phthalate

*Extraction solvent.* Ethanol diluted with *water* to have a relative density of 0.9389 to 0.9395 (2.4.29), measured with a pycnometer.

*Stock solution.* Dissolve 0.1 g of *di(2-ethylhexyl)phthalate* in the extraction solvent and dilute to 100 ml with the same solvent.

#### Standard solutions

- Dilute 20 ml of stock solution to 100 ml with extraction solvent.
- Dilute 10 ml of stock solution to 100 ml with extraction solvent.
- Dilute 5 ml of stock solution to 100 ml with extraction solvent.

- Dilute 2 ml of stock solution to 100 ml with extraction solvent.
- Dilute 1 ml of stock solution to 100 ml with extraction solvent.

Measure the absorbances of the standard solutions at the maximum at about 272 nm, using the extraction solvent as blank and plot a curve of absorbance against the concentration of di(2-ethylhexyl)phthalate (2.4.7).

*Extraction procedure.* Using the donor tubing and the needle or adaptor, fill the empty container with a volume equal to half the nominal volume with the extraction solvent, previously heated to 37° in a well-stoppered flask. Expel the air completely from the container and seal the donor tube. Immerse the filled container in a horizontal position in a water-bath maintained at 37 ± 1° for 60 ± 1 minutes without shaking. Remove the container from the water-bath, invert it gently ten times and transfer the contents to a glass flask. Immediately measure the *absorbance* at the maximum at about 272 nm, using the extraction solvent as blank (2.4.7).

Determine the concentration of di(2-ethylhexyl)phthalate in milligrams per 100 ml of the extract from the calibration curve. The concentration does not exceed

10 mg per 100 ml for containers of nominal volume greater than 300 ml but not greater than 500 ml;

13 mg per 100 ml for containers of nominal volume greater than 150 ml but not greater than 300 ml;

14 mg per 100 ml for containers of nominal volume up to 150 ml.

**Oxidisable substances.** Immediately after preparation of solution A, transfer to a borosilicate-glass flask a quantity corresponding to 8 per cent of the nominal capacity of the container. At the same time, prepare a blank using an equal volume of the freshly prepared solution B in another borosilicate-glass flask. To each solution add 20.0 ml of 0.002M *potassium permanganate* and 1 ml of 1M *sulphuric acid*. Allow to stand at room temperature, protected from light, for 15 minutes. To each solution add 0.1 g of *potassium iodide*. Allow to stand protected from light for 5 minutes and titrate immediately with 0.01M *sodium thiosulphate*, using 0.25 ml of starch solution as indicator. The difference between the two titrations is not more than 2.0 ml.

**Residue on evaporation.** Evaporate to dryness 100 ml of solution A in a borosilicate-glass beaker, previously heated to 105°. Evaporate to dryness in the same conditions 100 ml of solution B. Dry to constant weight at 105°. The difference between the weights of the residues is not more than 3 mg.

#### 6.4.3 Sterile Containers of Plasticised Poly(vinyl chloride) for Blood containing an Anticoagulant Solution

Unless otherwise authorised as described in the introductory part of section 6.2.3 of chapter 6.2, the nature and composition



of the material from which the containers are made complies with the requirements described under Empty sterile containers of plasticised poly(vinyl chloride) for blood and blood components (6.4.2).

Sterile plastic containers containing an anticoagulant solution are used for the collection, storage and administration of blood. Before filling they comply with the description and characteristics described under Empty sterile containers of plasticised poly(vinyl chloride) for blood and blood components (6.4.2).

After addition of the anticoagulant solution the containers comply with the tests described under Sterile plastic containers for blood and blood components (6.4.1) and with the following additional tests:

**Light absorption.** Measure the light absorption of the anticoagulant solution from the container in the range 250 nm

to 350 nm using an anticoagulant solution of the same composition that has not been in contact with a plastic material as blank. The absorbance at the maximum at about 280 nm is not more than 0.5 (2.4.7).

**Extractable di(2-ethylhexyl)phthalate.** Carefully remove the anticoagulant solution by means of the flexible transfer tube. Using a funnel fitted to the tube, completely fill the container with *water*, leave in contact for 1 minute, squeezing the container gently and empty completely. Repeat the rinsing. The container then complies with the test described under Empty sterile containers of plasticised poly(vinyl chloride) for blood and blood components (6.4.2).

**Volume of anticoagulant solution.** The volume does not differ by more than  $\pm 10$  per cent from the stated volume when determined by emptying the container and collecting the anticoagulant solution in a graduated cylinder.

## 7. TABLES

7.1	Names, Symbols and Atomic Weights of Elements	....
7.2.	Weights and Measure: SI Units	....
7.3.	Abbreviations and Symbols	....

## 7.1 Names, Symbols and Atomic Weights of Elements

 $^{12}\text{C} = 12$ 

<i>Element</i>	<i>Symbol</i>	<i>Atomic Weight</i>	<i>Element</i>	<i>Symbol</i>	<i>Atomic Weight</i>
Aluminium	Al	26.9815	Molybdenum	Mo	95.94
Antimony	Sb	121.757	Neodymium	Nd	144.24
Argon	Ar	39.948	Neon	Ne	20.1797
Arsenic	As	74.9216	Nickel	Ni	58.6934
Barium	Ba	137.327	Niobium	Nb	92.9064
Beryllium	Be	9.0122	Nitrogen	N	14.0067
Bismuth	Bi	208.9804	Osmium	Os	190.2
Boron	B	10.811	Oxygen	O	15.9994
Bromine	Br	79.904	Palladium	Pd	106.42
Cadmium	Cd	112.411	Phosphorus	P	30.9738
Caesium	Cs	132.9054	Platinum	Pt	195.08
Calcium	Ca	40.078	Potassium	K	39.0983
Carbon	C	12.011	Praseodymium	Pr	140.9077
Cerium	Ce	140.115	Rhenium	Re	186.207
Chlorine	Cl	35.4527	Rhodium	Rh	102.9055
Chromium	Cr	51.9961	Rubidium	Rb	85.4678
Cobalt	Co	58.9332	Ruthenium	Ru	101.07
Copper	Cu	63.546	Samarium	Sm	150.36
Dysprosium	Dy	162.50	Scandium	Sc	44.9559
Erbium	Er	167.26	Selenium	Se	78.96
Europium	Eu	151.965	Silicon	Si	28.0855
Fluorine	F	18.9984	Silver	Ag	107.8682
Gadolinium	Gd	157.25	Sodium	Na	22.9898
Gallium	Ga	69.723	Strontium	Sr	87.62
Germanium	Ge	72.61	Sulphur	S	32.066
Gold	Au	196.9665	Tantalum	Ta	180.9479
Hafnium	Hf	178.49	Technetium	Tc	(97)
Helium	He	4.0026	Tellurium	Te	127.60
Holmium	Ho	163.9303	Terbium	Tb	158.9253
Hydrogen	H	1.0079	Thallium	Tl	204.3833
Indium	In	114.82	Thorium	Th	232.0381
Iodine	I	126.9045	Thulium	Tm	168.9342
Iridium	Ir	192.22	Tin	Sn	118.70
Iron	Fe	55.847	Titanium	Ti	47.88
Krypton	Kr	83.80	Tungsten	W	183.85
Lanthanum	La	138.9055	Uranium	U	238.0289
Lead	Pb	207.2	Vanadium	V	50.9415
Lithium	Li	6.941	Xenon	Xe	131.29
Lutetium	Lu	174.967	Ytterbium	Yb	173.04
Magnesium	Mg	24.3050	Yttrium	Y	88.9059
Manganese	Mn	54.9381	Zinc	Zn	65.39
Mercury	Hg	200.59	Zirconium	Zr	91.224

The above-mentioned atomic weights are those published in 1989 by the International Union of Pure and Applied Chemistry (*Pure App. Chem.* 1991, 63, 978).

## 7.2. Weights And Measure: SI Units

The names and symbols for units of measurement used in this Pharmacopoeia are generally the International System of Units (SI) or the CGS metric units.

The SI comprises three categories of units, namely basic units, derived units and supplementary units. The basic units are given below in Table 1.

The derived units may be formed by combining the basic units according to certain algebraic relationships between the corresponding quantities. Some of these derived units with their special names and symbols and their equivalence with other units are shown in Table 3.

Table 1

Quantity	Name of the basic SI Unit	Symbol
Length	metre	m
Mass	kilogram	Kg
Time	second	s
Electric Current	ampere	A
Thermodynamic temperature	kelvin	K
Amount of Substance	mole	mol
Luminous intensity	candela	cd

The prefixes shown in Table 2 are used to form the names and symbols of the decimal multiples and sub-multiples of SI units.

Table 2

Factor	Prefix	Symbol
$10^9$	giga	G
$10^6$	mega	M
$10^3$	kilo	k
$10^2$	hecto	h
$10^1$	deca	da
$10^{-1}$	deci	d
$10^{-2}$	centi	c
$10^{-3}$	milli	m
$10^{-6}$	micro	$\mu$
$10^{-9}$	nano	n
$10^{-12}$	pico	p

Certain units of the SI which have not yet been classified as basic or derived are known as supplementary units and are shown in Table 4.

Table 4

Quantity	Name of supplementary SI units	Symbol
Plane angle	radian	rad
Solid angle	steradian	sr

Some important and widely used units outside the international system are shown in Table 5.

Table 3

Quantity	Names of derived SI units	Symbol	Expressions in basic SI units	Equivalence with other units
Absorbed dose of ionising radiation	gray	Gy	$m^2s^{-2}$	1 Gy = 1 joule per kg
Energy, work, quantity of heat	joule	J	$Kg m^2s^{-2}$	1 J = $10^7$ ergs
Electrical potential, potential difference, electromotive force	volt	V	$Kg m^2A^{-1}s^{-3}$	
Electric resistance	ohm	$\Omega$	$Kg m^2A^{-2}s^{-3}$	
Force	newton	N	$Kg m s^{-2}$	1 N = $10^5$ dynes
Frequency	hertz	Hz	$s^{-1}$	1 Hz = 1 cycle per second
Power	watt	$\Omega$	$Kg m^2s^{-3}$	
Pressure	pascal	Pa	$Kg m^{-1}s^{-2}$	1 kPa = 7.5 mm Hg = 7.5 torr
Radioactivity	becquerel	Bq	$s^{-1}$	1 Bq = $2.7036 \times 10^{-11}$ curies



Table 5

Quantity	Unit Name	Symbol	Value in SI units
Time	minute	min	1 min = 60 s
	Hour	h	1 h = 60 min = 3600 s
	day	d	1 d = 24 h = 86400 s
Volume	litre	l	1 l = 1 d m <sup>3</sup> = 10 <sup>-3</sup> m <sup>3</sup>
Mass	tonne	t	1 t = 10 <sup>3</sup> kg
Rotational Frequency	revolution per minute	r/min	1 r/min = (1/60) s <sup>-1</sup>

### 7.3 Abbreviations and Symbols

ATCC	American Type Culture Collection
$[\alpha]_D^{20}$	Specific optical rotation at 20° at the wavelength of the D line of sodium
$[\alpha]_D^{25}$	Specific optical rotation at 25° at the wavelength of the D line of sodium
bp	Boiling point
BS	British Standard
DNA	Deoxyribonucleic Acid
ED <sub>50</sub>	Effective dose 50 (the dose of the preparation that will be effective in 50 % of the treated animals)
g	Gram
<i>g</i>	Acceleration due to gravity
HIV	Human immunodeficiency virus
ID <sub>50</sub>	Infective dose 50 ( the dose of the micro-organism that infects 50% of the animals inoculated)
IPRS	Indian Pharmacopoeia Reference Substance
IS	Indian Standard
ISO	International Organisation for Standardization
IU	International Unit
IUPAC	International Union of Pure and Applied Chemistry
K	Capacity factor
LD <sub>50</sub>	Lethal dose 50 ( the dose of the preparation or organism that kills 50 % of the animals inoculated.
$\lambda$	Wavelength
M	Molarity
MID	Minimum infective dose
MLD	Minimum lethal dose
mp	Melting point
mEq	Milliequivalent

---

mmol	Millimole
mol	Gram-molecular weight (mole)
mOsmol	Unit of osmolar concentration expressed as milliosmols of solute
N	Normality
NCIMB	National Collection of Industrial and Marine Bacteria
NCPF	National Collection of Pathogenic Fungi
NCTC	National Collection of Type Cultures
NCYC	National Collection of Yeast Cultures
PD <sub>50</sub>	Protective dose 50 (the dose of the preparation that will protect 50 % of the animals inoculated)
ppm	Parts per million
psi	Pounds per square inch
R	Resolution
R <sub>f</sub>	Used in Thin-layer chromatography to indicate the ratio of the distance traveled by a substance to the Distance traveled by the solvent front
Rh	Relative humidity
RS	Reference substance
RSD	Related standard deviation
RT	Retention time
rpm	Revolutions per minute
S.D.	Standard deviation
SN <sub>50</sub>	Serum neutralising dose 50 (the dose of the preparation that will protect 50 per cent of the cultures against the specified amount of virus)
Sp.gr.	Specific Gravity
Wt. per ml.	Weight per millilitre